

Effective: April 1, 2016

---

TITLE PAGE

THIS PRODUCT GUIDE WILL BECOME EFFECTIVE ON APRIL 1, 2016 PENDING APPROVAL FROM THE CALIFORNIA  
PUBLIC UTILITIES COMMISSION OF FRONTIER CALIFORNIA INC.'S ADVICE LETTER 12732

SOME TARIFFED SERVICES ARE NOT AFFECTED BY ADVICE LETTER 12732, SUCH AS BASIC RESIDENTIAL SERVICE,  
911 SERVICE AND YOUR CHOICE OF A LONG DISTANCE PROVIDER AND THEREFORE WILL NOT BE FOUND IN THIS  
PRODUCT GUIDE.

Spanish 800-921-8101

PRODUCT GUIDE  
for  
Rates and Charges Together  
With Terms and Conditions Applicable To  
Services Provided In The Territories Served By  
FRONTIER CALIFORNIA INC.  
(FRONTIER)

Within The State Of  
California

Effective: September 24, 2017

---

GENERAL TABLE OF CONTENTS

<u>SECTION</u>	<u>DESCRIPTION</u>
0	TABLE OF CONTENTS
1	DEFINITIONS OF TERMS
2	GENERAL TERMS AND CONDITIONS
3	SERVICE CHARGES (nonrecurring installation charges)
4	LOCAL EXCHANGE SERVICE
5	LOCAL EXCHANGES, EXTENDED SERVICE AREAS AND ZONE USAGE MEASUREMENT EXCHANGES AND SERVICE
6	GENERAL SERVICES
7	CUSTOM CALLING SERVICES
8	BUNDLED/ PACKAGED SERVICES
9	PROMOTIONAL OFFERINGS
10	COMPETITIVE RESPONSE
11	CENTREX SERVICES
12	PRIVATE BRANCH EXCHANGE SERVICE
13	INTEGRATED SERVICES DIGITAL NETWORK (ISDN) – PRIMARY RATE INTERFACE (PRI) / BASIC RATE INTERFACE (BRI)
14	DIGITAL NETWORK SERVICES
15	ADVANCED DATA SERVICES
16	ADVANCED INTELLIGENT NETWORK(AIN) SERVICES
17	INFO CONTACT 900 AND 976 SERVICES
18	INSIDE WIRE, INTRABUILDING CABLE, NETWORK FACILITIES & ASSOCIATED DEMARCATION POINTS
19	FRONTIER CALLING PLANS
20	OPERATOR SERVICES
21	DIRECTORY SERVICES
22	SERVICES FOR ENHANCED SERVICE PROVIDERS (ESP)
23	EMPLOYEES SERVICES
24	VIDEO DIGITAL TRANSPORT
25	RADIO TELEPHONE SERVICE
26	N11 DIALING SERVICES
27	CUSTOM ROUTING SERVICE
28	INTRALATA TOLL SERVICE
29	CUSTOMER OWNED PAY TELEPHONE (COPT) SERVICE
30	WIDE AREA TELECOMMUNICATIONS (WATS) AND 800 SERVICES
31	FACILITIES BASED SERVICES (LOCAL, INTRASTATE ACCESS AND INTRALATA TOLL) (LOCAL, INTRASTATE ACCESS AND INTRALATA TOLL)
32	SHARED PRIVATE LINE SERVICES
33	SWITCHED DATA SERVICES
34	CUSTOMER OWNED PAY TELEPHONE (COPT) RESALE SERVICES (WHOLESALE)
35	CALIFORNIA TELECONNECT FUND (CTF) DISCOUNTED SERVICES
D&R	DEFINITIONS & RULES
G1	GRANDFATHERED SERVICES

(N)

DEFINITIONS OF TERMS

Definitions may be found in the General Exchange Tariff Schedule, No. D&R, Definitions and Rules.

Effective: April 1, 2016

---

GENERAL TERMS AND CONDITIONS

I. APPLICATION

- A. This Product Guide sets forth the prices, charges, terms and conditions under which Customers ("Customer," "you" or "your") agree to use the services (as defined below) and under which Frontier California Inc. (Frontier) agrees to provide the services to Customers, unless otherwise noted. The general terms and conditions set forth below apply to all services in the Product Guide.
- B. The Product Guide is set forth on the Frontier website (the "Website") at:  
<http://carrier.frontiercorp.com/crtf/tariffs/index.cfm?fuseaction=main&sctnID=19>.  
You may also obtain further information regarding the terms and conditions applicable to the ordered service by telephoning Frontier at 800-921-8101 for residential customers or 800-921-8102 for business customers.
- C. The Product Guide becomes a binding contract following your acceptance of the terms and conditions applicable to the ordered service. You are deemed to have accepted the terms of the Product Guide applicable to your service upon your order of, use of, or payment for the service.
- D. The services in the Product Guide are not subject to the prices, charges, terms and conditions contained in Frontier California Inc., tariffs on file with the California Public Utilities Commission (CPUC), except to the extent (i) selected tariff provisions have been expressly incorporated into the Product Guide or (ii) the terms and conditions in Frontier California Inc.'s tariffs are required by federal or state law or by CPUC decisions or orders.
- E. Unless expressly stated otherwise, the Product Guide also applies to Customers who have entered into a separate contract for services for a specified time period; provided, however, in the event of a conflict between the terms in the separate contract and the terms in the Product Guide, the terms in the separate contract shall control with respect to services subject to that contract.

---

GENERAL TERMS AND CONDITIONS

II. GENERAL TERMS AND CONDITIONS

- A. Services. The term "service" or "services" is defined to mean all retail telecommunications products or services offered by Frontier in California for which the prices, charges, terms and conditions of sale are specified in the Product Guide except where the context requires otherwise.
- B. Prices. You are responsible for all charges associated with the services and rate plan selected, including all taxes, fees, surcharges, usage charges, telecommunications surcharges (e.g., Universal Service Fund fees) or other applicable governmental charges due on account of the services. Such taxes, fees and/or surcharges are subject to change without notice to Customer except as may be required by law. Charges for ancillary services, including but not limited to, charges for installation, change orders, directory assistance and operator services used by Customer will be imposed at Frontier's current prices and such charges are also subject to change without notice to Customer except as may be required by law. Promotional pricing and terms will expire in accordance with the terms applicable to each promotion, without further notice to you.
- C. Unauthorized Use. Frontier shall not be liable for any damages, including charges for services that Customer may incur as a result of the unauthorized use or misuse of the services by Customer's family, guests, employees or third parties. Customer shall remain responsible for such charges to the extent permitted by law.
- D. Indemnification. Customer agrees to defend, indemnify and hold Frontier, its employees, affiliates and agents, harmless from any and all losses, claims, demands, damages, expenses (including reasonable attorneys' fees), or any liability whatsoever, arising from any use of the services by you or any person you permit to use the services, including without limitation, liability resulting from the content of communication such as defamation, fraud or invasion of privacy, any combination of the services with other products or services not provided by Frontier, any modification of the services or any infringement of intellectual property.
- E. **WARRANTY DISCLAIMER. EXCEPT AS OTHERWISE EXPRESSLY PROVIDED IN THE PRODUCT GUIDE, FRONTIER DISCLAIMS ANY AND ALL REPRESENTATIONS AND WARRANTIES, EXPRESS, IMPLIED OR ARISING BY COURSE OF PERFORMANCE, DEALING, CUSTOM OR TRADE USAGE, INCLUDING BUT NOT LIMITED TO THE IMPLIED WARRANTIES OF MERCHANTABILITY, FITNESS FOR A PARTICULAR PURPOSE (EVEN IF WE KNEW OR SHOULD HAVE KNOWN SUCH PURPOSE) AND NON-INFRINGEMENT. YOU AGREE THAT THE SERVICES ARE PROVIDED ON AN "AS IS" AND "AS AVAILABLE" BASIS. FRONTIER DOES NOT WARRANT THAT THE SERVICES WILL MEET YOUR NEEDS, OR WILL BE UNINTERRUPTED, ERROR-FREE, OR SECURE.**

Effective: April 1, 2016

---

GENERAL TERMS AND CONDITIONS

III. LIMITATION OF LIABILITY

- A. EXCEPT FOR DAMAGES RESULTING FROM THE UNAUTHORIZED OR ILLEGAL USE OF THE SERVICES BY YOU OR YOUR FAMILY, GUESTS OR EMPLOYEES, NEITHER PARTY (NOR ITS SUPPLIERS OR AFFILIATES) SHALL BE LIABLE TO THE OTHER PARTY FOR PUNITIVE, SPECIAL, CONSEQUENTIAL, INCIDENTAL OR INDIRECT DAMAGES INCLUDING WITHOUT LIMITATION, LOSS OF BUSINESS PROFITS, OR OTHER COMMERCIAL OR ECONOMIC LOSS ARISING IN CONNECTION WITH THE SERVICES, EVEN IF THE PARTY KNEW OR SHOULD HAVE KNOWN OF THE POSSIBILITY OF SUCH DAMAGES.
- B. EITHER PARTY'S MAXIMUM TOTAL LIABILITY TO THE OTHER PARTY IN CONNECTION WITH THE SERVICES, FOR ANY AND ALL CAUSES OF ACTION AND CLAIMS, SHALL BE:
1. FOR DAMAGES DUE TO FAILURES OR DISRUPTIONS IN THE SERVICES CAUSED BY THE PARTY'S NEGLIGENCE OR BREACH OF OBLIGATIONS UNDER THE PRODUCT GUIDE, THE CHARGES FOR THE AFFECTED SERVICES FOR THE PERIOD OF THE FAILURE;
  2. FOR DAMAGE TO REAL OR PERSONAL PROPERTY OR BODILY INJURY OR DEATH TO ANY PERSON PROXIMATELY CAUSED BY THE PARTY'S NEGLIGENCE, THE AMOUNT OF DIRECT DAMAGES PROVEN;
  3. FOR INDEMNITY, THE REMEDIES SET FORTH IN SECTION B.4;
  4. FOR ANY DAMAGES ARISING OUT OF THE WILLFUL OR INTENTIONAL MISCONDUCT OF THE PARTY, THE AMOUNT OF DIRECT DAMAGES PROVEN;
  5. FOR ALL OTHER DAMAGES NOT SET FORTH ABOVE AND NOT EXCLUDED UNDER THE PRODUCT GUIDE, EACH PARTY'S MAXIMUM LIABILITY DURING ANY TWELVE MONTH PERIOD SHALL BE LIMITED TO THE LESSER OF (i) DIRECT DAMAGES PROVEN, OR (ii) THE AMOUNT PAID BY CUSTOMER TO FRONTIER UNDER THE PRODUCT GUIDE FOR THE ONE MONTH PERIOD PRIOR TO ACCRUAL OF THE MOST RECENT CAUSE OF ACTION.
- C. NOTHING IN THIS SECTION SHALL LIMIT YOUR LIABILITY TO FRONTIER FOR ANY AND ALL CHARGES INCURRED FOR THE SERVICES.

Effective: April 1, 2016

---

GENERAL TERMS AND CONDITIONS

IV. TERMINATION OF SERVICES

Frontier may discontinue or limit use of the services by a Customer for non-payment, non-compliance with Company terms, fraudulent use, and other conditions as provided in the Frontier's General Exchange Tariff, Schedule D&R, Rule No. 9 as incorporated herein.

V. PERFORMANCE EXCUSED

Frontier's performance shall be excused if said performance is delayed or prevented due to events known as force majeure, acts of any third party, or any cause(s) beyond our reasonable control, including, but not limited to, fire, vandalism, cut cable, power failures or labor difficulties.

VI. CUSTOMER RESPONSIBILITIES

You agree to provide us with the access and support required to allow us to implement, maintain and provide the services. You shall ensure that the facilities or equipment provided by you are properly interconnected with the services, facilities and equipment provided by Frontier. Frontier shall not be liable for any damages or losses caused by the failure of equipment, inside wire or other facilities provided by you or a third party and you shall be liable if such facilities cause damage to Frontier, our customers, and/or our providers. You are solely responsible for the selection, implementation and maintenance of security features for protection against unauthorized or fraudulent use of services and Frontier shall have no liability therefore.

VII. MISCELLANEOUS

- A. The Product Guide, including these general terms and conditions, constitutes the entire agreement of the parties with respect to the services and takes the place of all prior agreements, negotiations, and representations, whether written or oral, concerning the services. Frontier may revise the terms and conditions of the Product Guide. We may decrease prices without prior notice. Increases to the prices or changes to the Product Guide resulting in more-restrictive terms or conditions shall be effective no sooner than thirty (30) days after notice is provided in a bill insert, as a message printed on your bill, in a separate mailing, or by any other reasonable method permitted by law. If you do not agree to the revision(s), you may terminate your service(s) within thirty (30) days of the date the notice was mailed, and you will not incur charges for early termination of an applicable term agreement. Failure to terminate your service(s) within thirty (30) days of the date the notice was mailed will be deemed acceptance of such revisions, and any termination after said date will be subject to early termination charges. Price increases and more-restrictive terms do not include (i) the introduction of a new service, (ii) the addition of a new feature to existing service, or (iii) the imposition of governmental charges. You shall pay all charges incurred up to the time of service discontinuance. By continuing to use, pay for, or order the service(s) after revisions are in effect, you are accepting and agreeing to all revisions.
- B. Either party's failure to enforce any of the provisions of the Product Guide or to exercise any right or option is not a waiver of any such provision, right, or option, and shall not affect the validity of the Product Guide. Any waiver must be written and signed by the Parties. The invalidity or unenforceability of any part of the Product Guide will not affect the other parts thereof, and the remaining terms and conditions of the Product Guide shall continue to apply as necessary to reflect the original intention of the parties.
- C. Customer shall not transfer, assign or resell the services without the prior written consent of Frontier. Frontier may freely assign or transfer all or part of our rights under the Product Guide without notice provided Frontier shall notify affected Customers at least 30 days before any transfer of ownership or customer base.

Effective: July 7, 2016

---

GENERAL TERMS AND CONDITIONS

VIII. SERVICE PERFORMANCE GUARANTEE FOR RESIDENTIAL CUSTOMERS

- A. If a residence-class or a Universal Lifeline Telephone Service customer requests installation of a new or a subsequent service or repair of an existing service, and the installation or repair is not completed as agreed, the customer will be eligible to receive a credit of \$25.00.
- B. One credit per service order or per trouble report may be applied, if an installation or repair involves services from this Product Guide but excludes the following:  
Customer Premises Equipment (CPE) and Inside Wire  
Facilities for IntraState Access
- C. Each credit shall be limited to \$25.00 for each service order or trouble report.
- D. A credit will be extended in accordance with the above conditions at the request of the customer.
- E. A credit will be extended in accordance with the above conditions only after the Company fails to meet a commitment or fails to restore Company-owned facilities used to provide any service other than those specified above as exceptions.
- F. Credits will be provided to residential-class and California Lifeline Telephone Program customers within all exchanges. (T)
- G. The Company's commitment to residential customers shall constitute a limited exception to the limitations of liability contained in III. Limitation of Liability of this Section. The Company's commitment to residential customers in no way constitutes a waiver of the provisions in III. Limitation of Liability of this Section.



Effective: April 1, 2016

---

GENERAL TERMS AND CONDITIONS

IX. TERMINATION LIABILITY

- A. In the event the service is terminated by the customer prior to completion of the current term commitment period, the customer shall be liable for one of the early termination charges described below.
- B. Early termination charges will apply only to those rate elements under a term commitment period. If any rates for the service are increased during the term period, exclusive of any increase due to local, state or federal fees, taxes or surcharges, the customer may terminate the service without incurring an early termination charge.
1. For all applicable customers excluding business customers identified in 2. below, the amount of the early termination charge will be 25% of the monthly recurring charge(s) (MRC), excluding any promotional discounts, for the remainder of the term in months. For example:

$$25\% \times \text{MRC} \times \# \text{ of Lines/Channels/Paths} \times \text{Remainder of Term} = \text{Termination Charge}$$

End of Term Options

- a. Prior to the end of the term commitment period, the customer may select one of the following options, to be effective at the end of the term:
- (1) Renew their term commitment,
  - (2) Commit to a new term period,
  - (3) Arrange for a change of service, or
  - (4) Arrange for termination of the service.
- b. In the event the customer does not select one of the above options, the customer will be converted to the shortest-term period available under this Product Guide (e.g., month-to-month, one year, etc.) for the same service, and will be subject to the applicable term commitment, if any, unless the customer terminates the service within sixty (60) days of the conversion date.
2. The following terms apply to business customers who subscribe to the following services on or after June 1, 2014, new Basic Exchange Access Line Business Service lines or trunks or Centrex Communications System lines, under the 24-month term plan, or those business customers with eligible lines under Item 1 above who choose to subscribe those lines to a 24-month plan under these terms.

In the event the service is terminated by the customer prior to the completion of the current term commitment period, the customer shall be liable for an early termination charge, except as noted below. The amount of the early termination charge will be 100% of the monthly recurring charge(s) (MRC), excluding any promotional discounts for the line(s) being terminated multiplied by the remainder of the term in months.

For example:

$$\text{Termination Charge} = 100\% \times \text{MRC} \times \# \text{ of lines terminating early} \times \text{remainder of term}$$

The remainder of term will be calculated based upon the number of days left in the 24-month term divided by 30.

Effective: April 1, 2016

---

GENERAL TERMS AND CONDITIONS

IX. TERMINATION LIABILITY (Continued)

B.2. (Continued)

End of Term Options:

1. The plan will automatically renew for another 24-month term under the same terms, except that the monthly rate will be adjusted to the prevailing plan rate in effect at the time of renewal. In the event the customer terminates service within the first 30 days following automatic renewal, the Termination Liability Charge will be waived.
2. The customer may call anytime within 30 days before the end of a term to arrange for termination of the service or conversion to a month-to-month service at the end of the then current term. Customers may also terminate their term plan within the first 60 days following an automatic renewal and the early termination charge will be waived. The plan will not automatically renew if the customer or the Company contacts the other to cancel within sixty (60) days before the renewal date.

Coterminous Lines – The terms and expiration dates of all lines subscribed to or renewed under Plan 2 and within the same account will be coterminous based upon the date of the first line established.

Lines subscribed to under 2. Coterminous Lines above may not be combined with features, call plans, usage or other voice services under a term commitment. For lines subscribed to under 2. Coterminous Lines above, other voice services and/or features may be purchased only on a month-to-month basis.

C. Early termination charges will not be assessed under the following circumstances:

1. Customer moves existing service either to a new location within the same address and/or same building (inside move) or to a new location (outside move) and maintains that service for the remainder of the term;  
  
Customer attempts to move the existing service to a new location within Company's service area, but the service is unavailable;
2. Customer renegotiates a new term commitment plan for the same service before the current term commitment expires and the value of the new term commitment is equal to or greater than the remaining value of the current term commitment; or
3. Customer changes to another service or upgrades service to a higher speed or capacity under a term commitment, provided the following conditions are met:
  - a. The value of the new term commitment is equal to or greater than the remaining value of the current term commitment;
  - b. The Company provides the new service via this Product Guide or on an individual case basis (ICB), and
  - c. The order to discontinue the existing service and the order for the new or upgraded service are received by the Company at the same time.

Effective: April 1, 2016

---

GENERAL TERMS AND CONDITIONS

IX. TERMINATION LIABILITY (Continued)

C. Early termination charges will not be assessed under the following circumstances: (Continued)

4. Customer terminates service within thirty (30) days after the date a notice is mailed by Company with changes to the Product Guide resulting in an increase to the price or more-restrictive terms or conditions applicable to the terminated service.
5. Customer with Voice services, Frame Relay or Asynchronous Transfer Mode ATM services changes to another service, upgrades service to a higher speed or capacity or advanced technology under a term commitment, provided the following conditions are met:
  - a. The value of the new term commitment is equal to or greater than the remaining value of the current term commitment;
  - b. The Company or its affiliates provides the new service via this Product Guide, similar documents or commercial agreement, or on an individual case basis (ICB), and
  - c. The order to discontinue the existing service and the order for the new or upgraded service are received by the Company or its affiliates at the same time.

D. Prior to the End of Term Options

Subscribers of services based on packet, optical and wave technology, including Frame Relay Service, Transparent LAN Services, Asynchronous Transfer Mode Cell Relay Service (ATMCRS), and data services in bandwidths greater than 1.5 Mbps may terminate such services by giving 30 days' notice, either written or electronic. Applicable Early Termination charges will be assessed.

X. SPECIAL CONSTRUCTION

For rates, terms and conditions associated with Special Construction see Frontier's Product Guide, Section 3 and General Exchange Tariff Schedule No. D&R, Rule 27 Rule 28, Rule 33, Schedule No. A-10 and Facilities for Intrastate Access Tariff C-1.

Effective: April 1, 2016

---

SERVICE CHARGES

TABLE OF CONTENTS

	<u>SHEET NO.</u>
I. SPECIAL CONDITIONS	1
II. RATES AND CHARGES - All Exchange Services	5
A. Service Order Activity	5
1. Initial Order	
2. Subsequent Order	5
B. Customers Returning to the Company (Winback)	6
C. Central Office Activity	7
D. Outside Facility Connection Charge	7
E. Network Interface Device	7
F. Premises Visit Charge	7
G. Installment Payments	7
III. RATES AND CHARGES - Other Services, Moves and Changes of Wiring and Rearrangements	8
A. Miscellaneous Services	8
B. Toll Denial Service	8
C. Station Change	8
D. Charges for Line Extension and Service Connection Facilities in Suburban Areas	9
E. Special Construction	11

Effective: April 1, 2016

---

SERVICE CHARGES

I. SPECIAL CONDITIONS

A. Service order activity is defined as the taking and processing of a customer's request for the establishment of service or, changes or additions to existing services. Service order activity is classified as either initial (establishment of customer account) or subsequent (changes to customer account) depending on the nature of the customer's request. Primary lines added to a customer's service will always require the insurance of an initial order.

B. SUBSEQUENT ORDER CHARGE

The subsequent order charge will apply to moves, changes or additions and to the following activities:

1. Business Service

- a. When the service is assumed by the receiver or trustee, executor or administrator of an estate.
- b. When the name of a business concern is changed without a change in responsibility for payment of the telephone bills.
- c. EBSS services may be moved from one location to another within the same central office area where there is no interruption of the service other than that incident to the work performed.

2. Residence Service

- a. When an employer has arranged for service in the residence of an employee and the latter assumes the responsibility for payment for the service personally or when the responsibility for payment of the charges for the service of the employee is assumed by the employer.
- b. When the service is assumed by a receiver or administrator of the estate of the former customer.
- c. When the customer removes a Frontier Calling Service and adds a different Frontier Calling Service.

The subsequent order charge does not apply when residence service is assumed by a member of the former customer's immediate family or when the customer's name is changed by court order or marriage.

The subsequent order charge does not apply when a move or change of service is initiated by the Company.

Subsequent to a customer's listing appearing in the Street Address Telephone Directory the customer may request the listing to be omitted from future issues of the Street Address Telephone Directory without the subsequent order charge being applicable.

3. Moves and Changes

A change of location from one premises to another, will not be treated as a move but as a disconnect and a new installation.

Effective: April 1, 2016

---

SERVICE CHARGES

I. SPECIAL CONDITIONS (Continued)

C. SUPERSEDURE

A supersedure will be rated as initial order activity for the first central office line of an order and for each additional central office line on the same order.

D. CUSTOMERS RETURNING TO THE COMPANY (Winback)

1. A Transfer of Service charge is imposed when a customer elects to return to Frontier service from that of a Competitive Local Exchange Carrier (CLEC) reseller of Frontier's service. A per order charge will apply for each Residence and Business class of service. The Transfer of Service is not applicable when a residential customer returns to Frontier and elects to purchase Frontier Local Package, Frontier Local Package Extra, or Local and Toll Package.
2. Initial service order activity charges are assessed when a customer elects to return to Frontier service from a facilities-based Competitive Local Exchange Carrier (CLEC). The Initial Service Order Activity charges will apply for each Residence and Business class of service.

If a customer alleges that this service order activity is the result of an unauthorized change of local service provider.

E. CENTRAL OFFICE ACTIVITY

1. The Central Office Activity charge applies to all service activity within the central office for the establishment or change of service. This charge applies in all cases of access line service connection for non-Lifeline customers. The Central Office Activity Charge is associated with, but not limited to loop assignment, line and number assignment, C.O. cross-connect and line testing. This charge is independent of the Outside Facility Connection Charge.

2. Reconnection

A Reconnection Charge is applicable when a customer's service is reconnected with the same telephone number after a temporary disconnect for nonpayment. This charge applies to each telephone number temporarily disconnected.

An Initial Order Charge is applicable when a customer's service is completely disconnected for nonpayment and must be reestablished.

SERVICE CHARGES

I. SPECIAL CONDITIONS (Continued)

F. OUTSIDE FACILITY CONNECTION CHARGES

1. The Outside Facility Connection Charge applies when Company personnel are dispatched to perform work activities necessary for service connection other than repair and/or maintenance or for a total disconnect of service. The Outside Facility Connection Charge is assessed on a per service order per customer premises basis. The Outside Facility Connection Charge is associated with travel time, work activities outside the central office, including but not limited to the establishment of cross connect, drops and line testing, up to and including the network side of the demarcation point or protector. For charges associated with isolating the source of repair and/or maintenance problems on the customer's side of the demarcation point, see II. Rates and Charges in this Section.
2. The work activities for which the Outside Facility Connection Charge applies includes but is not limited to provision of access line service and/or equipment (other than maintenance replacement) for which a recurring monthly rate is applicable and/or when additional lines are installed.
3. When a customer or applicant initiated request requires outside facility connection work activities to be performed at more than one customer's or applicant's premises, multiple Outside Facility Connection Charges will be applicable.
4. The Outside Facility Connection Charge is not applicable to work activities deemed necessary for only repair or maintenance purposes. However, the charge may apply if, coincident with the repair or maintenance work activities, outside facility connection work activities are performed at the request of the customer.
5. The Outside Facility Connection Charge is not applicable in instances where the Company has reused previously assigned facilities and must perform outside facility connection work activities to reconnect service.

G. NETWORK INTERFACE DEVICE

This device is weatherproof housing designed to contain the station protector network interface and inside wire terminations. It provides for easy customer access to premises wiring and network interface while maintaining Company hardware security. Customers will be billed the Network Interface Device charge when a network interface device is requested by the customer for existing service. When this work is completed a Service Order Activity and Outside Facility Connection charge will also apply. There will be no Network Interface Device charge on new construction, but the Outside Facility Connection charge will apply.

Effective: April 1, 2016

---

SERVICE CHARGES

I. SPECIAL CONDITIONS (Continued)

H. PREMISES VISIT CHARGE

1. Applicable to the charge resulting from the Company repairman's visit to the customer's premises when a service difficulty is found to be the result of customer-provided facilities.
2. The Company will not repair, adjust or perform any work on customer-provided facilities.
3. At the request of the Company, the customer is responsible for disconnecting customer-provided facilities in order that the Company can determine the location of a trouble condition.
4. When a service difficulty or trouble is reported to the Company or is detected by personnel of the Company,
  - a. the Company will first endeavor to clear the trouble without a visit to the customer's premises,
  - b. If the trouble cannot be cleared, the Company will inform the customer of the trouble condition.
  - c. The customer-provided facilities will then be temporarily disconnected from the "Connecting Arrangement" provided by the Company, to determine if the trouble will clear. If disconnection of the customer-provided facilities does not clear the trouble and a visit to the customer's premises is required, the customer shall be responsible for the payment of all billed charges for visits by the Company to the customer's premises where a service difficulty or trouble report results from other than facilities provided by the Company.
  - d. Additionally, the customer may request the Company to defer its visit until the customer has his customer-provided facilities tested, in which case the Company will delay its visit.
  - e. If the customer asks the Company to defer its visit in accordance with (4) above, and does not disconnect his facilities or does not consent to a visit by the Company, the Company has the right to take such immediate action as may be necessary for the protection of its facilities, including temporary disconnection of service, and shall inform the customer of such action.
5. The customer is responsible for the payment of all Company charges for visits made to the customer's premises by the Company where a service difficulty or trouble report results from customer-provided facilities.
6. Visit charges provided for herein are in addition to charges billed to the customer as otherwise provided for in other sections of this product guide.

I. INSTALLMENT PAYMENTS

Service Connection Charges are allowed in the General Exchange Tariff, Schedule D&R Rule No. 9, Installment Billing – Service Connection Charges for installment billing of Initial Service Connection Charges.

- J. Nonrecurring Charges set forth in other sections will be in addition the charges set forth in this section.



Effective: January 26, 2020

SERVICE CHARGES

II. RATES AND CHARGES – All Exchange Services

A. SERVICE ORDER ACTIVITY

		<u>Nonrecurring Charge</u>		
		<u>Business</u>	<u>Residence</u>	
2.	Initial Order			
3.	First central office line on order			
	(1) Centrex	No Charge		
	(2) PBX	\$60.00		
	(3) All other services	60.00	\$29.00	(l)
(b)	Each additional central office line on the same order			
	(a) Centrex	No Charge		
	(2) PBX	46.00		
	(3) All other services	46.00	25.00	
4.	Subsequent Order <sup>1</sup>			
(a)	Moves and Changes (All applicable individual line services, except Frontier Calling Services)	40.00	24.00	(l)
	(1) Frontier Calling Services	15.00	7.50	

<sup>1</sup> Residential customers who request conversion from flat rate basic exchange service to measured rate basic exchange service, or vice versa, will be exempt from service order change charges for a maximum of two changes per access line for a ninety (90) day period.

Effective: January 26, 2020

SERVICE CHARGES

II. RATES AND CHARGES - All Exchange Services (Continued)

A. SERVICE ORDER ACTIVITY (Continued)

	<u>Nonrecurring Charge</u>		
	<u>Business</u>	<u>Residence</u>	
2. Subsequent Order <sup>1</sup> (Continued)			
(b) Additions, other than central office lines (All applicable individual line services, except Frontier Calling Services)	\$40.00	\$24.00	(l)
(1) Frontier Calling Services	15.00	7.50	
(c) Inside Wire Maintenance Plan (IWMP)	Each Line	No Charge	
(d) INC Service Agreement Establishment Building Owner	No Charge		
(e) Transfer of Service, per order <sup>2</sup>	40.00	21.00	

B. CUSTOMERS RETURNING TO THE COMPANY (Winback)  
 (see Special Condition D preceding)

<sup>1</sup> Residential customers who request conversion from flat rate basic exchange service to measured rate basic exchange service, or vice versa, will be exempt from service order change charges for a maximum of two changes per access line for a ninety (90) day period.

<sup>2</sup> Does not apply to residential customers purchasing Frontier Local Package, Frontier Local Package Extra, or Local and Toll Package.

Effective: January 26, 2020

SERVICE CHARGES

II. RATES AND CHARGES - All Exchange Services (Continued)

C. CENTRAL OFFICE ACTIVITY  
(SEE SPECIAL CONDITION E)

Nonrecurring Charge

Business                      Residence

1. All lines	\$46.00	\$25.00	
2. except			
(a) Centrex	No Charge		
(b) Reconnection Charge, each line Applicable after Temporary Disconnection	60.00	33.00	(l)

D. OUTSIDE FACILITY CONNECTION CHARGE

1. All services, each service order,	86.64	42.10	
2. except			
(a) Centrex and DID, each service order	86.64		

E. NETWORK INTERFACE DEVICE

10.00 <sup>1</sup>	10.00	
--------------------	-------	--

F. PREMISES VISIT CHARGE

Each visit to a customer's premises resulting from trouble conditions caused in whole or in part by customer-provided facilities.

Nonrecurring Charge

1. Exchange Service, per visit	\$86.64
2. Private Line Service, per visit	86.64
3. Wide Area Telephone Service, per visit	86.64

G. INSTALLMENT PAYMENTS

(see Special Condition I preceding)

<sup>1</sup> Applicable to single line business only.

Effective: April 1, 2016

---

SERVICE CHARGES

III. RATES AND CHARGES - Other services, moves and changes of wiring and rearrangements  
(in addition to Rates A1.b., D. and E. preceding)

		<u>Nonrecurring Charge</u>
A.	<u>MISCELLANEOUS SERVICES</u>	
1.	Moving, rearranging or changing services or apparatus for identical services other than as provided for elsewhere in this section	75 percent of the nonrecurring and/or service connection charge applicable to the service offering rounded to the lower twenty-five cent multiple.
2.	When the item is a component of other service or a system and no nonrecurring charge is applicable	Actual cost of work performed on premises
B.	<u>TOLL DENIAL SERVICE</u>	
1.	Selective change of prefixes or codes in each preselected dialing arrangement each trunk or line so arranged	<u>Nonrecurring Charge</u> \$3.55
C.	<u>STATION CHANGE</u>	
1.	EBSS	
(a)	Number change or change in restrictive status of an EBSS station	
(1)	First line of an order	14.00
(2)	Each additional line of the same order	2.75

Effective: April 1, 2016

---

SERVICE CHARGES

III. RATES AND CHARGES - Other services, moves and changes of wiring and rearrangements  
(in addition to Rates A1.b., D. and E. preceding) (Continued)

D. CHARGES FOR LINE EXTENSION AND SERVICE CONNECTION FACILITIES IN SUBURBAN AREAS

1. APPLICABILITY

Applicable to charges for line extensions and service connections or in addition to line extension and service connection provisions of the General Exchange Tariff, Schedule D&R, Rule No. 27 and the regular service connection charges in this Section.

2. TERRITORY

Within the suburban areas of all exchanges as said areas are defined on maps in this Product Guide.

3. RATES AND CHARGES

Charge

- |  |           |
|--|-----------|
| (a) Aerial, or at Company's option, underground reinforcements to plant along existing exchange or suitable toll telephone circuits of the Company | No Charge |
| (b) Aerial, or at Company's option, underground extension to plant along existing exchange or suitable toll telephone circuits of the Company      |           |

Applications Prior to August 7, 1984

- |  |           |
|--|-----------|
| (a) Free footage Allowance - the Company will construct at its expense a maximum of 700 feet of line extension and/or a maximum of 300 feet of service connection per applicant. | No Charge |
| (b) Extensions to plant exceeding free footage allowance   |           |
| (1) First 100 feet or fraction thereof of line extension and/or service connection per applicant   | \$50.00   |
| (2) Each additional foot or fraction thereof of line extension and/or service connection.  | .50       |

Effective: February 13, 2018

SERVICE CHARGES

III. RATES AND CHARGES - Other services, moves and changes of wiring and rearrangements  
(in addition to Rates A1.b., D. and E. preceding) (Continued)

D. CHARGES FOR LINE EXTENSION AND SERVICE CONNECTION FACILITIES IN SUBURBAN AREAS  
(Continued)

3. RATES AND CHARGES (Continued)

Charge

Applications on or before August 7, 1984

(C)

(a) Free Footage Allowance - the Company will construct at its expense a maximum of 700 feet of line extension and/or a maximum of 300 feet of service connection per applicant

No Charge

(b) Extensions to plant exceeding free footage allowance <sup>1</sup>

(1) First 100 feet or fraction thereof of line extension and/or service connection per applicant

Actual Cost

(2) Each additional foot or fraction thereof of line extension and/or service connection

Actual Cost

San Gabriel Canyon Exchange

(1) Free Footage Allowance - the Company will construct at its expense a maximum of 300 feet of line extension and/or a maximum of 100 feet of service connection per applicant

No Charge

(2) Each additional foot or fraction thereof of line extension and/or service connection <sup>1</sup>

Actual Cost

Applications on or after February 13, 2018

(N)

(a) Free Footage Allowance - the Company will construct at its expense a maximum of 200 feet of line extension and/or a maximum of 100 feet of service connection per applicant

No Charge

(b) Extensions to plant exceeding free footage allowance

Each additional foot or fraction thereof of line extension and/or service connection

Actual Cost <sup>2</sup>

(N)

<sup>1</sup> The property owner, or his or her agent, will be required to make a nonrefundable deposit to cover the cost of the engineering study before the Utility provides the estimated total costs of construction.

<sup>2</sup> Includes Income Tax Component as listed in its Local Exchange Tariff, Schedule Cal. P.U.C. No. D&R, Rule No. 2.

(N)

---

SERVICE CHARGES

III. RATES AND CHARGES - Other services, moves and changes of wiring and rearrangements  
(in addition to Rates A1.b., D. and E. preceding) (Continued)

E. SPECIAL CONSTRUCTION

1. General

This section contains the regulations, rates and charges applicable for Special Construction of Utility facilities which are used to provide FIA.

When Special Construction of FIA is required, the provisions of this section apply in addition to regulations, rates and charges set forth in other sections of this Product Guide as well as Rule 2 shown in the General Exchange Tariff, Schedule No. D&R.

(a) Conditions Requiring Special Construction

Special Construction is required when facilities, suitable to the customer, are not available to meet the order and one or more of the following conditions exist:

- (1) The Utility has no other requirement for the facilities requested
- (2) It is requested that FIA be furnished using a type of facility, or via a route, other than that which the Utility would otherwise utilize in furnishing the requested FIA.
- (3) More facilities are requested than are required to satisfy its order for FIA.
- (4) It is requested that construction be expedited resulting in added cost to the Utility.
- (5) It is requested that temporary facilities be constructed until permanent facilities are available.

(b) Filing of Charges

Rates and charges for Special Construction will be filed on an individual case basis. After charges have been filed and have become effective they will apply from the date that the special construction was provided.

(c) Ownership of Facilities

The Utility retains ownership of all specially constructed facilities except for those facilities constructed by connecting companies or carriers, even though the customer may be required to pay Special Construction Charges.

Effective: April 1, 2016

---

SERVICE CHARGES

III. RATES AND CHARGES - Other services, moves and changes of wiring and rearrangements  
(in addition to Rates A1.b., D. and E. preceding) (Continued)

E. SPECIAL CONSTRUCTION (Continued)

1. General (Continued)

(d) Interval to Provide FIA

Based on available information and the type of FIA ordered, the Utility will establish a scheduled date for the installation of necessary facilities. The date will be established on an individual case basis and provided to the customer.

(e) Special Construction Involving Interstate and Intrastate FIA

When Special Construction involves facilities used to provide both interstate and intrastate FIA, charges for the portion of the construction used to provide intrastate FIA shall be in accordance with this Product Guide. Charges for the portion of the construction used to provide interstate FIA shall be in accordance with the Frontier Operating Companies Tariff FCC No. 14.

2. Liabilities, Charges and Payments

(a) General

This section describes the various charges and liabilities that apply when the Utility provides special construction of FIA in accordance with a customer's specific request. Once the customer is notified of all charges and liabilities, the customer must provide the Utility with written approval prior to the start of construction. If more than one condition requiring special construction is involved, charges for each condition apply.

(b) Payment of Charges

Payment is due upon presentation of a bill for the specially constructed facilities.

(c) Start/End of Billing

Billing of recurring charges for specially constructed FIA starts on the day after the FIA are provided. Billing accrues through and includes the day that the specially constructed FIA are discontinued. Monthly charges will normally be billed one month in advance.

(d) Partial Payments

The Utility will require a customer which has a proven history of late payments to the Utility, or does not have established credit, to make a partial payment for the portion of the estimated cost of the Special Construction for which the customer is subject to a nonrecurring charge. Partial payments will be requested as costs are incurred and will be credited to the customer's account. Partial payments will not exceed the total nonrecurring charge to the customer for the Special Construction.



Effective: April 1, 2016

---

SERVICE CHARGES

III. RATES AND CHARGES - Other services, moves and changes of wiring and rearrangements  
(in addition to Rates A1.b., D. and E. preceding) (Continued)

E. SPECIAL CONSTRUCTION (Continued)

2. Liabilities, Charges and Payments (Continued)

(e) Development of Liabilities and Charges

The customer has the option of accepting the liabilities and charges based on estimated or actual costs. Estimated costs will be used unless the customer notifies the Utility of the selection of the actual cost option in writing prior to the start of special construction.

Under the estimated cost option, special construction liabilities and charges are developed based on estimated costs and will be filed in this Product Guide.

Under the actual cost option, if all actual costs are not available prior to the in-service date of the FIA, estimated special construction charges will be filed in this Product Guide. As soon as the actual costs, including costs of maintaining and tiling these costs, are subsequently determined, the estimated charges will be adjusted to reflect the actual costs. The filed charges will then reflect actual costs existing at the time the CIA are provided.

(f) Type of Contingent Liability

Depending on the specifics associated with each individual case, the Maximum Termination Liability may be applicable to Special Construction.

(1) Maximum Termination Liability (MTL)

An MTL has two components, an amount and a specified period of time.

The amount is equal to all non-recoverable costs less the net salvage value; (e.g., depreciation, return, income tax associated with the specially constructed facilities.) The amount will be amortized over the average account life of the specially constructed facilities. The standard liability period is the average account life of the specially constructed facilities expressed in years.

At the customer's option, an optional liability period shorter than the average account life may be established. If the customer chooses an optional liability period, the MTL amortization schedule will not change. The remaining MTL amount for the period between expiration of the optional liability period and the expiration of the amortization schedule will be due as a lump sum payment at the time the optional liability period expires unless the case of Special Construction is extended.

Effective: April 1, 2016

---

SERVICE CHARGES

III. RATES AND CHARGES - Other services, moves and changes of wiring and rearrangements  
(in addition to Rates A1.b., D. and E. preceding) (Continued)

E. SPECIAL CONSTRUCTION (Continued)

2. Liabilities, Charges and Payments (Continued)

(f) Type of Contingent Liability (Continued)

Prior to the expiration of an optional liability period, the customer has the option to (1) extend the use of the specially constructed FIA establishing a new liability period, or (2) terminate the case of Special Construction and pay the lump sum payment.

The Utility will notify the customer six months in advance of the expiration date of the optional liability period. The customer must provide the Utility with written notification of its intention to be received one month prior to the expiration of the optional liability period. Failure to do so, and payment of the next month's charges, will result in extension of the case of the Special Construction and the establishment of a new liability period equal to the remaining amortization period. A case preparation charge will always apply if the Special Construction case is extended.

(g) Types of Charges

Two categories of charges may be applicable for Special Construction. These charges are nonrecurring charges and recurring charges. These categories are described below.

(1) Nonrecurring Charges

One or more of the following nonrecurring charges may apply for each completed case of Special Construction or inquiry for Special Construction:

- Case Preparation
- Termination
- Cancellation
- Expediting the Construction
- Optional Payment Charges

a. Case Preparation Charge

The charge for case preparation includes such items as the administrative expense associated with preparing and listing the charges in the Product Guide. This includes such items as (a) Tariff and/or Product Guide preparation and processing and (b) gross receipts and surcharge taxes.

Effective: April 1, 2016

---

SERVICE CHARGES

III. RATES AND CHARGES - Other services, moves and changes of wiring and rearrangements  
(in addition to Rates A1.b., D. and E. preceding) (Continued)

E. SPECIAL CONSTRUCTION (Continued)

2. Liabilities, Charges and Payments (Continued)

(g) Types of Charges (Continued)

(2) Termination Charge

A termination charge applies when, at the customer's request, FIA provided on specially constructed facilities which have a Maximum Termination Liability are discontinued prior to the expiration of the liability period.

The charge reflects the unamortized portion of the non-recoverable cost at the time of termination of the specially constructed FIA adjusted for tax effects, for net salvage and for possible reuse. Administrative costs associated with the specific case of special construction and any cost for restoring a location to its original condition are also included. Termination charges will never exceed the MT-

(3) Cancellation Charge

If the customer cancels an order with which Special Construction is associated prior to the in-service date of the FIA, a cancellation charge will apply. The charge will include all non-recoverable costs less the net salvage value incurred by the Utility up to and including the time of cancellation.

(4) Expediting Charge

An expediting charge applies when a customer requests that special construction be completed on an expedited basis. The charge is equal to the difference in the estimated cost of construction on an expedited basis and construction without expediting.

(5) Optional Payment Charge

The customer may elect to pay an optional payment charge when it requests special construction of facilities utilizing (1) a type of facilities or (2) a route other than that which the Utility would otherwise utilize in furnishing the requested service. Payment of this charge will result in a lower recurring charge for special construction. This election must be made in writing before special construction starts.

Effective: April 1, 2016

---

SERVICE CHARGES

III. RATES AND CHARGES - Other services, moves and changes of wiring and rearrangements  
(in addition to Rates A1.b., D. and E. preceding) (Continued)

E. SPECIAL CONSTRUCTION (Continued)

2. Liabilities, Charges and Payments (Continued)

(g) Types of Charges (Continued)

(5) Optional Payment Charge (Continued)

If this election is coupled with the actual cost option, the optional payment charge will reflect the actual cost of the specially constructed facilities.

a. Development of Optional Payment Charge

This charge is equal to the excess installed cost or the total non-recoverable cost, whichever is less (based on estimated or actual costs as elected by the customer). The methodology for the development of the Optional Payment Charge is set forth in Frontier Operating Companies Tariff FCC No. 14.

b. Replacement Charge

If any portion of the specially constructed FIA, for which an optional payment charge has been paid, requires replacement involving capital investment, a charge for replacement will apply.

This charge will in the same ratio as the initial optional payment charge was to the installed cost of the specially constructed FIA. The customer will be notified in writing that the replacement is required. Replacement will not be made without the customer's order. If any portion of the FIA subject to the replacement charge fails, the FIA will not be restored until the customer orders the replacement. The methodology for development of the Replacement Charge is set forth in the Frontier Operating Companies Tariff FCC No. 14.

Recurring Charges

These charges apply on a monthly or annual basis for specially constructed FIA. There are two conditions for which recurring charges apply. When a customer:

- requests a facility route or type other than that which the Utility would utilize to provide a FIA.
- makes a request resulting in the Utility leasing transmission or other equipment from private vendors to provide a FIA (Lease Charge).

Effective: April 1, 2016

---

SERVICE CHARGES

III. RATES AND CHARGES - Other services, moves and changes of wiring and rearrangements  
(in addition to Rates A1.b., D. and E. preceding) (Continued)

E. SPECIAL CONSTRUCTION (Continued)

2. Liabilities, Charges and Payments (Continued)

(g) Types of Charges (Continued)

(5) Optional Payment Charge (Continued)

c. Charge for Route or Type Other Than Normal

When the customer requests special construction using a route or type of FIA other than that which the Utility would normally use, a recurring charge is applicable. The charge is the difference between the estimated recurring costs of the specially constructed FIA and the estimated recurring costs of the FIA the Utility would normally use. The charge will be no greater than the recurring costs of the specially constructed FIA.

1. If the customer elects to pay an optional payment charge, the portion of the recurring charge for the excess investment covered by the optional payment excludes capital cost items (depreciation, return on investment and federal income tax on that return). The remaining recurring expense cost items associated with the Optional Payment (maintenance, administration, and other taxes), are increased by a ten percent management fee, and will be included in the recurring charge.

The portion of any recurring charge associated with any remaining special construction investment will include both capital and expense costs. The ten percent management fee is not applied to this portion of the recurring charge. The methodology for development of the charge for route and type other than normal is set forth in Frontier Operating Companies Tariff FCC No. 14.

2. If the customer has elected the actual cost option, the Recurring Charge will be adjusted to reflect the actual cost of the new construction when the cost is determined. This adjusted Recurring Charge is applicable from the start of FIA.

d. Lease Charge

A lease charge applies when the Utility leases equipment (e.g., portable microwave equipment) in order to provide FIA to meet the customer's requirements. The amount of the charge is the net added cost to the Utility caused by the lease.

---

SERVICE CHARGES

III. RATES AND CHARGES - Other services, moves and changes of wiring and rearrangements  
(in addition to Rates A1.b., D. and E. preceding) (Continued)

E. SPECIAL CONSTRUCTION (Continued)

2. Liabilities, Charges and Payments (Continued)

(h) Application of Charges

The charges for special construction are those charges which are in effect for the period that the special construction is furnished. If the charges for a period covered by a bill change after the bill has been rendered, the bill will be adjusted to reflect the new charges. Charges are based on special construction of (a) permanent FIA, or (b) temporary FIA.

(1) Special Construction of Permanent FIA

a. Special Construction When Permanent FIA Are Not Available and There Is No Other Requirement for Them

When permanent FIA are not available and the Utility constructs them and there is no other Utility need for the specially constructed FIA, a nonrecurring charge and a Maximum Termination Liability charge may be applicable.

b. Special Construction Using a Route or Type of FIA Other Than Normal

When the specially constructed FIA involve a route or type of FIA other than that which the Utility would ordinarily use, charges are based on the difference between the estimated costs of the specially constructed FIA and those the Utility would ordinarily use. A nonrecurring charge, a recurring charge, and a Maximum Termination Liability charge may be applicable.

c. Special Construction of a Greater Quantity of FIA Than Necessary to Satisfy the Customer's Order for Service

When the Utility constructs more FIA than is required to satisfy the customer's order, additional charges will apply. These charges may include a nonrecurring charge, a recurring charge, and a Maximum Termination Liability charge.

d. Special Construction Expedited at Greater Cost Than Would Otherwise be Incurred

When construction is expedited resulting in added costs, a nonrecurring expediting charge applies.

(i) Special Construction of Temporary FIA Order

When permanent FIA are not available and temporary FIA are constructed pending the construction of permanent FIA, a nonrecurring charge, and a Maximum Termination Liability charge may be applicable.

Effective: April 1, 2016

---

SERVICE CHARGES

III. RATES AND CHARGES - Other services, moves and changes of wiring and rearrangements  
(in addition to Rates A1.b., D. and E. preceding) (Continued)

E. SPECIAL CONSTRUCTION (Continued)

3. Deferral of the In-Service of FIA

(a) General

The customer may request the Utility to defer the in-service of FIA on specially constructed FIA. If the deferral is not in compliance with the Ordering Option for FIA, the special construction case is considered to be cancelled and cancellation charges apply. Requests for deferral must be in writing and are subject to the following regulations:

(b) Construction Has Not Started

If the Utility has not incurred any costs (e.g., engineering and/or Installation) before receiving the customer's request for deferral, no charge applies other than the Case Preparation Charge. However, the original quotation is subject to Utility review at the time of reinstatement to determine if the original charges are still valid. Any change in liabilities and charges requires the concurrence of the customer in writing. Additional Case Preparation Charges will also apply.

(c) Construction Has Started But Is Not Complete

If the construction of FIA has started, but has not been completed, before the Utility receives the customer's request for deferral, charges apply. The charges vary depending on whether all or some of the FIA ordered are deferred.

(1) All FIA Are Deferred

When all FIA involving special construction are deferred, a charge equal to the costs incurred during each month of the deferral applies. Those costs include the recurring costs for that portion of the FIA already completed and any other costs associated with the deferral. The Case Preparation Charge also applies.

(2) Some But Not All FIA Are Deferred

When some, but not all, FIA utilizing the specially constructed FIA are deferred, the special construction case will be completed. Maximum Termination Liability will apply in addition to Case Preparation Charges, and any recurring charges associated with the Special Construction.

(d) Construction Complete

If the construction of FIA has been completed before the Utility receives the customer's request for deferral, the case preparation charge, and Maximum Termination Liability as originally determined, will apply and any recurring charges associated with the Special Construction.

Effective: April 1, 2016

---

SERVICE CHARGES

III. RATES AND CHARGES - Other services, moves and changes of wiring and rearrangements  
(in addition to Rates A1.b., D. and E. preceding) (Continued)

E. SPECIAL CONSTRUCTION (Continued)

4. Special Construction Charges

(Charges for Customers Choosing the Optional Liability Period to Provide Permanent FIA)

This section contains the Special Construction charges to provide permanent FIA to individual customers. Charges are developed on an individual case basis for a specific customer and shall be filed in this section.

<u>Customer Name/ Effective Date</u>	<u>Description and Location</u>	<u>MTL/NRC MRC</u>
AT&T Communications September 21, 1987	(2) DS1 circuits between Cell Site 18 for L.A. Cellular at Whitewater Mt. and the Palm Springs East Central Office. (In addition, rates and charges in Section III, Special Access apply).	NRC \$81,130.00
AT&T Communications (eff. date of filing)	(1) DS1 circuit between Cell Site 19 for L.A. Cellular at N. Indio Hill and the Palm Springs East Central Office. (In addition, rates and charges in Section III, Special Access apply).	NRC \$13,859.36



Effective: April 1, 2016

---

LOCAL EXCHANGE SERVICE

TABLE OF CONTENTS

	<u>SHEET NO.</u>
I. SPECIAL CONDITIONS	1
A. General	1
B. Rotary Hunting Line/ Rotary Service	1
C. Vacation Service (Residential)	1
D. Reservation of Telephone Number (Business)	2
E. Trunk Line Services	2
F. Direct Inward Dialing Service (DID)	2
G. PBX Discount Pricing Plan (DPP)	6
H. Business Line Discount Pricing Plan (DPP)	7
I. Discounts for Qualifying Entities	8
J. Additional Terminations of Primary Service	8
K. Digital Format Trunking	8
II. RATES AND CHARGES	9
A. Basic Exchange Access Line Business Services	9
B. Measured-Rate Service - Local Calling Rates	9
C. Measured-Rate Service - ZUM Zone 3 Calling Rates	10
D. Rotary Service	10
E. Vacation Service (Residential)	10
F. Reservation of Telephone Number (Business)	10
G. Extended Area Service Monthly Increments	11
H. Direct Inward Dialing Service (DID)	12
I. PBX Trunk Discount Pricing Plan	14
J. Business Line Discount Pricing Plan (DPP)	19
K. Digital Format Trunking	20

Effective: January 19, 2021

---

LOCAL EXCHANGE SERVICE

I. SPECIAL CONDITIONS

A. GENERAL

1. Rates for local calling are applicable to the duration in minutes (rounded upward) of each message originating from a measured-rate line and terminating at a location within the Local (serving) Exchange or within an Extended Service Area as set forth in Section 5, Local Exchanges, Extended Area Service and ZUM Zone 3.
2. All services listed may be furnished from any central office serving the exchange or district area at the discretion of the Company.
3. The rate for PBX trunks applies for each trunk ordered. Direct Inward Dialing Service (DID) station numbers may be purchased at rates set forth in this section.
4. Customers who subscribe to DID numbers for PBX trunks are required to keep 50% or more of the assigned numbers working at all times in order to retain assignment of their entire block of numbers. Customers must notify the Company if their usage level drops below 50% so that action can be initiated to reclaim the DID numbers.
5. In the Sierra Madre Exchange, the Company will provide, own and maintain all facilities between the central office and the boundary of the base rate area used to furnish service in the mountainous area located outside the base rate area and within the exchange area. The customer will provide, own and maintain all facilities used to provide service between the customer's station and the point of connection with the Company's facilities at the base rate area boundary. Exchange rates, based on the point of connection, will apply to these services.
6. While the Company's Basic Exchange Access Line Service may be used by the customer for dial-up access, the advertised speeds of the customer's modem may not be attainable with this service and are not guaranteed by the Company.

B. ROTARY HUNTING LINE/ ROTARY SERVICE

The term "Rotary Hunting Line" denotes the grouping of exchange access arrangements arranged for completion of calls when a line is busy by overflowing to vacant line in the same prefix, area code, and group that is available to receive a call. Rotary Hunting Line Service is available to all customers whether they have Local Exchange Access Service or Extended Area Service.

C. VACATION SERVICE\* (Residential)

Vacation Service is for numbers already in service. The customer's number must be working for at least 90 days in a calendar year. Numbers may be reserved for a period of not less than one month and up to a maximum of nine months.

The charges applicable to Vacation Service for residence customers, including Section 3 Service Charges, will be waived during the Vacation Service period when the customer subscribes to a FTR Regional Calling Plan Bundle that includes a Frontier® FiberOptic Internet product. If the account has multiple lines, one of which is a FTR Regional Calling Plan Bundle with a Frontier® FiberOptic Internet product, the Vacation Service charges for all lines on the account will be waived for the length of the Vacation Service period. (C)

During the Vacation Service period, the bundle term, if applicable, will also be suspended for customers subscribing to a FTR Regional Calling Plan Bundle with a Frontier® FiberOptic Internet product. At the end of the Vacation Service period, the bundle term will resume from where it was prior to the period of suspension. (C)

\* Vacation Service is grandfathered and limited to all existing subscribers at their existing locations as of June 30, 2020.

Effective: April 1, 2016

---

LOCAL EXCHANGE SERVICE

I. SPECIAL CONDITIONS (Continued)

D. RESERVATION OF TELEPHONE NUMBER (Business)

A business telephone number may be reserved after the listing in which the telephone number appears has been advanced to the directory and the customer subsequently delays or cancels the installation of the telephone service. The maximum period for which a telephone number may be reserved is 180 days.

E. TRUNK LINE SERVICES

1. U.S. Government-Owned PBX Systems - Military and Naval Installations

- a. The Company will own, furnish and maintain all lines, equipment and facilities used to furnish private branch exchange trunk line service for U.S. Government-owned PBX systems on military and naval installations to a point of connection with the U.S. Government-owned lines, which point of connection normally should be the base area boundary.
- b. The U.S. Government will own and furnish all lines, equipment and facilities beyond the point of connection as specified in a. above.
- c. All lines, equipment and facilities owned and furnished by the U.S. Government will be maintained at the expense of the U.S. Government.

2. Telephone systems owned and maintained by steamship companies on board their ships may be connected while in port with the exchange toll facilities of the Company where operating facilities permit.

F. DIRECT INWARD DIALING SERVICE (DID)

1. Equipment Arrangement

- a. This service is furnished where operating conditions and availability of facilities and equipment permit, subject to telephone number availability and in accordance with the terms and special conditions set forth in this guide.
- b. The Company will provide to the customer an equipment arrangement in the Company's central office to provide direct inward dialing service from the exchange and the message toll network directly to the customer premises.
  - (1) Where furnished with customer-provided dial switching equipment, terms and conditions for connection with customer-provided facilities and devices, as set forth in the General Exchange Tariff, Schedule D&R, specifically, but not limited to Rule No. 34 of the General Exchange Tariff customer-provided facilities connected to Company exchange facilities, will apply.
- c. In connection with the foregoing, where a reduction in the service is requested, the last equipment arrangement provided shall be considered to be the first removed.

Effective: April 1, 2016

---

LOCAL EXCHANGE SERVICE

I. SPECIAL CONDITIONS (Continued)

F. DIRECT INWARD DIALING SERVICE (DID) (Continued)

1. Equipment Arrangement (Continued)

- d. This service must be provided on all lines in an exchange trunk group arranged for inward dialing service. Sequential numbers will be furnished and billed for in blocks of 20, 40 and 100 at charges and rates shown herein. The minimum order placed by a customer shall be one block of 20 numbers.

On customer-provided systems, the customer shall provide all necessary terminating equipment to maintain Company specified levels.

- e. Customers must agree to subscribe to sufficient direct inward dialing service trunks to maintain an average grade of service, whereby not more than one call out of each one hundred call attempts will be blocked during the average busy hour of the busy week of the busy season as measured at the Company's central office.

If the customer fails to subscribe to a sufficient number of trunks, the service will be disconnected based on procedures outlined in the General Exchange Tariff, Schedule D&R, Rule 10.

- f. Customer-Provided Switching Systems must handle calls to all assigned numbers, including those that are not currently used with specific stations. Calls to numbers not currently used with specific stations must be routed by the customer to an attendant or a recorded announcement referring the caller to another number.
- g. Directory listings will be furnished in accordance with Section 19 of this Product Guide, Telephone Directory Service, as it applies to private branch exchange service. Direct inward dialing station numbers may be listed at appropriate rates. Customers are responsible for timely updating of all telephone number changes, disconnects, additions, etc in order to meet time schedule requirements for entry in or exclusion from the Company's telephone directory(s).
- h. Customer-provided equipment must meet industry standards established under direct distance dialing network requirement with regard to trunking, signaling, intercept, tone signals, etc.
- i. Rates and charges are in addition to the rates and charges for other Company services or facilities with which this service is associated. Such services or facilities are limited to network, access, and central office offerings.

---

LOCAL EXCHANGE SERVICE

I. SPECIAL CONDITIONS (Continued)

F. DIRECT INWARD DIALING SERVICE (DID) (Continued)

1. Equipment Arrangement (Continued)

- j. All changes in rearrangement of, or additions to this service made at the customers request will be billed at the appropriate charges specified herein or in other applicable sections of this guide, such as, but not limited to Section 3, Service Charges.

When changes, in rearrangements of, or additions to this service are caused by Company-initiated telephone prefix (or code) reassignments, changes will be made by the Company at no charge to the customer.

- k. Service provided from a step-by-step (non-electronic) central office or a central office utilizing a GTD-4600 as the serving switch is limited as follows:
- (1) When the customer subscribes to less than 1000 numbers, a separate trunk group is required for each group of 100 numbers and two digits will be forwarded to the customer premises.
  - (2) In order to have three digits forwarded to the customer premises, the customer must subscribe to a minimum of 1000 numbers which requires a separate trunk group for each 1000 numbers.
- l. Service provided from electronic central offices may be arranged to forward the number of digits to the customer premises as specified by the customer. A separate trunk group is not required for each group of numbers.
- m. When the customer requests non-direct inward dialing trunks changed to direct inward dialing trunks, these trunks will be considered new and the applicable service connection charges as shown in Section 3, Service Charges will apply.
- n. Discounted monthly rates are also available for DID Service when it is ordered in conjunction with PBX service.

Effective: February 2, 2018

---

LOCAL EXCHANGE SERVICE

I. SPECIAL CONDITIONS (Continued)

F. DIRECT INWARD DIALING SERVICE (DID) (Continued)

2. Extended Basic Referral

Extended Basic Referral permits incoming DID trunks to be placed on intercept and routed to a "change number announcement." This service allows a business DID customer who is relocating within the Company or changing numbers to have as many internal lines placed on intercept as desired. Dialing the customer's former DID number results in a prerecorded message which announces the new number.

- a. Extended Basic Referral is offered to DID customers in five (5) DID number increments and is subject to where facilities permit Extended Basic Referral. (C)
- b. Extended Basic Referral is offered as an enhancement to basic intercept service.
- c. Extended Basic Referral can only be ordered by business customers under two nonrecurring charge options. These service options are intervals of six months and twelve months.
- d. The customer can designate the quantity in five (5) DID Number increments to be placed on this service.
- e. This service must be ordered coincident with a service order request associated with discontinuing or changing a DID Number.
- f. The nonrecurring charge is in addition to all other Service Order Charges, Section 3 that may apply when this service is ordered.
- g. This service can only be ordered where DID service is offered.

3. Direct Inward/Outward Dialing Service (DIOD)

- a. Direct Inward/Outward Dialing Service (DIOD) is a central office based service that permits incoming calls to reach customer provided equipment without the assistance of an attendant, and allows the trunk to be used to place outgoing calls. This service is provisioned with E&M signaling and a 4-wire connection at the customer's premises. Touch Calling is a required feature of this service. Rotary hunt does not apply.
- b. The assignment of telephone numbers and the sequence of numbers assigned to a customer are made at the discretion of the Company. Telephone number charges, terms and conditions found in the DID section of this Product Guide apply to DIOD service.
- c. Customer-Provided Switching Systems must handle calls to all assigned numbers, including those that are not currently used with specific stations. Calls to numbers not currently used with specific stations must be routed by the customer to a recorded announcement referring the caller to another number.
- d. Trunks arranged for DIOD service may not be combined with trunk groups arranged to provide Direct Inward Dialing (DID) service. Overflow of calls between the two arrangements is not permitted.

Effective: November 1, 2020

---

LOCAL EXCHANGE SERVICE

I. SPECIAL CONDITIONS (Continued)

F. DIRECT INWARD DIALING SERVICE (DID) (Continued)

3. Direct Inward/Outward Dialing Service (DIOD) (Continued)

- e. DIOD service is provided from central offices equipped to provide this service and subject to the availability of facilities.
- f. If a customer's normal serving central office is not equipped to provide DIOD service or the customer so requests, the service may be provided where facilities permit, from a Company central office different than that which normally serves the customer, but still within the same LATA, at the additional rates specified herein and under the terms and conditions applicable for Foreign Exchange (FX) service.
- g. See Section 2 for termination liability terms and conditions.
- h. When DIOD service becomes available or is subsequently requested from the central office that normally serves the customer, the service may be transferred to the normal serving central office. If the customer requests such a transfer, the customer will be subject to a change in telephone numbers and will also incur initial nonrecurring charges and applicable Service Order Charges in Section 3.
- i. A change in central office equipment could require the customer to discontinue the service or obtain service from another central office. The Company makes no guarantees and assumes no liability for loss of service to the customer, resulting from the conversion or upgrade of central office equipment.
- j. DIOD service works in conjunction with Direct Inward Dialing (DID) service and the charges specified in II. RATES are in addition to applicable rates and charges for DID service specified in II. Rates and Charges following.

G. PBX DISCOUNT PRICING PLAN (DPP)\*

(C)

- 1. Customers subscribing to the 12, 24, and 36 month PBX Trunk Discount Pricing Plans are eligible for IntraLATA Toll usage discounts. Customers may also receive discounts on DID Service.
- 2. Minimum Monthly Billing
  - a. IntraLata Toll Service

A minimum monthly billing applies for all IntraLATA Toll usage as follows. For customers with a 12, 24 or 36 month PBX Term and less than 5000 minutes of use (MOU) per month, the Minimum Monthly Billing will be \$25.00 per PBX Trunk. For customers with a 12, 24, or 36 month PBX Term and 5000 or more MOU per month, the Minimum Monthly Billing will be negotiated.

The Company will true up the actual toll usage annually. If the amount is less than 12 times the total PBX trunks multiplied by the per trunk minimum, the customer will be billed for the difference.

The customer is also liable for the minimum monthly billing should the service be terminated.

\* PBX and Business Line Discount Pricing Plan (DPP) is grandfathered and limited to all existing subscribers at their existing locations.

(N)  
(N)

Effective: November 1, 2020

---

LOCAL EXCHANGE SERVICE

I. SPECIAL CONDITIONS (Continued)

G. PBX DISCOUNT PRICING PLAN (DPP)\* (Continued) (C)

3. Termination Liability

a. PBX Trunks and DID Service - See Section 2 of this Product Guide for termination liability terms and conditions.

b. IntraLata Toll Service

A IntraLATA Toll Termination Liability charge applies. This charge is applied when a PBX/IntraLATA Toll term is terminated by the customer prior to the end of the respective 12 or 36 month term. The liability for customers with less than 5000 MOU per month will be \$25.00 per trunk for the initial ordered quantity of PBX Trunks times the number of months remaining in the term.

c. In the event the customer terminates service within the first 30 days of subscription or automatic renewal term, the customer will be liable for the applicable monthly rate incurred by the customer and nonrecurring charges; however, the Termination Liability will be waived. If the customer terminates service after 30 days of subscription or renewal but prior to completion of the term commitment period, the customer shall be liable for an early termination charge and nonrecurring charges.

4. A Customer's volume discounts may be calculated based on an aggregate of all locations statewide.

5. Additional PBX trunks and DID groups may be added under a Discount Pricing Plan (DPP) at the same rate as the current DPP for the remainder of the DPP term.

6. Before the expiration of a discount pricing plan period, a customer may elect to subscribe to a new Discount Pricing Plan with the same or longer term period than the current plan. When a new discount pricing plan is chosen, the new rate applies for the new term period and the previous rates no longer apply.

7. Section 17, Frontier Calling Plans has a list of services for which Discount Pricing Plans are available.

H. BUSINESS LINE DISCOUNT PRICING PLAN (DPP)\* (C)

1. Termination Liability - See Section 2 of this Product Guide for termination liability terms and conditions.

2. In the event the customer terminates service within the first 30 days of subscription or automatic renewal, the customer will be liable for the applicable monthly rate incurred by the customer and nonrecurring charges; however, the Termination Liability will be waived. If the customer terminates service after 30 days of subscription or automatic renewal but prior to completion of the term commitment period, the customer shall be liable for an early termination charge and nonrecurring charges.

\* PBX and Business Line Discount Pricing Plan (DPP) is grandfathered and limited to all existing subscribers at their existing locations. (N)  
(N)



Effective: April 1, 2016

---

LOCAL EXCHANGE SERVICE

I. SPECIAL CONDITIONS (Continued)

I. DISCOUNTS FOR QUALIFYING ENTITIES

Basic Exchange Access Line Business Services, Measured-Rate Service and PBX Trunk are the only services contained in this section that are eligible for the Teleconnect Discount Service. Refer to the General Exchange Tariff, Schedule K-8 for qualifications and discounts for Schools, Libraries, Health Care Providers, and Community Based Organizations.

J. ADDITIONAL TERMINATIONS OF PRIMARY SERVICE

1. Mileage rates, as set forth in Section 6 of this Product Guide in contiguous exchanges of the Company, are applicable to additional terminations of residence services located off the premises on which primary service is located.
2. Off-premises terminations of residence service will be provided on business premises under the following conditions:
3. Additional terminations of residence lines will be installed off the premises and beyond the same continuous property as the residence on which the primary service is located when such lines appear on a telephone answering service.
4. Additional terminations of residence services will be installed in establishments such as hospitals, convalescent centers and sanitariums for use of customers who are confined as patients.

K. DIGITAL FORMAT TRUNKING

1. This Service is applicable to the provision of Direct-Inward-Dialing/Direct-Outward Dialing (DID/DOD) trunks in digital format with answer back supervision from the Company to the customer's facilities.
2. DID/DOD trunks allow incoming and outgoing calling in a digital transmission format and, optionally, may utilize answer supervision on DOD trunks.
3. DID/DOD trunks are provided from the Company's central office to the customer's premises in a high capacity digital transmission format.
4. Services in this schedule will be provided on the basis of a minimum service period of 60 months. Any customer who discontinues service prior to the completion of the 60 month period will be required to pay for the remaining months.
5. Channel bank is necessary if the customer's equipment is not compatible with the Company's digital facilities.
6. This service is available only to former Contel customers in the exchanges listed in Section 5 of this Product Guide.

Effective: May 1, 2024

LOCAL EXCHANGE SERVICE

II. RATES AND CHARGES

A.	<u>BASIC EXCHANGE ACCESS LINE BUSINESS SERVICES</u>	Monthly Rate <sup>1</sup>	
1.	Measured-Rate Service		
a.	Each individual line or trunk line <sup>2</sup>	\$40.65	
b.	Each individual line or trunk line <sup>3</sup>	43.00	
c.	Keyline or multiline <sup>3</sup>	45.40	
2.	PBX Trunk		
a.	Each Trunk Line <sup>2</sup>	50.10	(I)
b.	Each Trunk Line <sup>3</sup>	55.40	(I)

B. MEASURED-RATE SERVICE - Local Calling Rates

Local Exchange and Extended Area Service rates per message for Zones 1 and 2. See Section 5 for Local Calling Areas.

1.	Business Measured Rate Service			
		First Minute Or Portion Thereof	Additional Minute Or Portion Thereof	
a.	Monday Through Friday			
	8:00 A.M. to 5:00 P.M. <sup>4</sup>	\$.033	\$.033	
	5:00 P.M. to 11:00 P.M. <sup>4</sup>	.033	.033	
	11:00 P.M. to 8:00 A.M. <sup>4</sup>	.033	.033	
b.	Saturday, Sunday, Holiday			
	All Hours	.033	.033	

<sup>1</sup> Plus Extended Area Service increments as identified in this section.

<sup>2</sup> Rates applicable to exchanges listed in Section 5, Local Exchanges and Extended Service Areas, Sheet 2.

<sup>3</sup> Rates applicable to exchanges listed in Section 5, Local Exchanges and Extended Service Areas, Sheet 3.

<sup>4</sup> To, but not including.

Effective: January 8, 2021

LOCAL EXCHANGE SERVICE

II. RATES AND CHARGES (Continued)

C. MEASURED-RATE SERVICE - ZUM Zone 3 Calling Rates. See Section 4A for Zone 3 listings.

	First Minute <sup>2,3</sup>		Additional Minute <sup>2,3</sup>	
	<u>Business</u>	<u>Residence</u>	<u>Business</u>	<u>Residence</u>
1. Monday Through Friday				
8:00 A.M. to 5:00 P.M. <sup>1,4</sup>	\$0.100	\$0.000 (R)	\$0.090	\$0.000 (R)
5:00 P.M. to 11:00 P.M. <sup>1,4</sup>	0.100	0.000 (R)	0.090	0.000 (R)
11:00 P.M. to 8:00 A.M. <sup>1,4</sup>	0.100	0.000 (R)	0.090	0.000 (R)
2. Saturday, Sunday, Holiday				
All Hours	0.050	0.000 (R)	0.050	0.000 (R)

Monthly  
Rate

D. ROTARY SERVICE

- |   |        |
|---|--------|
| 1. Each individual line or PBX trunk line, including foreign exchange service, arranged for rotary service. | \$1.50 |
| 2. Each rotary number reserved  | 1.50   |

E. VACATION SERVICE\* (Residential) 6.00

F. RESERVATION OF TELEPHONE NUMBER (Business) 6.00

<sup>1</sup> To, but not including.

<sup>2</sup> Or portion thereof.

<sup>3</sup> Fractional amounts are rounded to the nearest cent.

<sup>4</sup> Zone Calling rates are applicable during the time of day when the conversation takes place. In cases where a message extends beyond one rate period, the appropriate rate treatment as specified applies to the respective periods of conversation.

\* Vacation Service is grandfathered and limited to all existing subscribers at their existing locations as of June 30, 2020.

LOCAL EXCHANGE SERVICE

II. RATES AND CHARGES (Continued)

G. EXTENDED AREA SERVICE MONTHLY INCREMENTS

<u>Exchanges</u>	<u>Monthly Increments Business Measured</u>
Gaviota (to Santa Barbara)	\$12.80
Lake Hughes (to Lancaster)	6.35
Los Alamos (to Santa Maria)	6.35
Palm Desert (to Palm Springs)	2.60
Palm Springs (to Palm Desert)	1.45
Santa Maria (to Los Alamos)	.70
Trona (to Ridgecrest)	6.35
Bishop 1 party/CTX/keyline/multiline	1.40
PBX Trunk/CTX	2.00
Big Pine 1 party/CTX/keyline/multiline	4.60
Lifeline	--
PBX Trunk/CTX	6.90
Lone Pine 1 party/CTX/keyline/multiline	.80
PBX/CTX	1.15
Olancha 1 party/CTX/keyline/multiline	7.30
Lifeline	--
PBX Trunk/CTX	10.95
Pine Creek 1 party/CTX/keyline/multiline	4.60
Lifeline	--
PBX Trunk/CTX	6.90
Laytonville Sherwood Ranch D.A.	3.15

Effective: April 1, 2016

LOCAL EXCHANGE SERVICE

II. RATES AND CHARGES (Continued)

H. DIRECT INWARD DIALING SERVICE (DID)

	<u>BTC</u> (36)	<u>Nonrecurring</u> <u>Charge</u>	<u>Monthly</u> <u>Rate</u>
1. Equipment arrangement in Company central office necessary to provide in-dialing from the exchange and message toll network directly to a dial switching equipment installed on the customer premises <sup>1</sup>			
a. Option 1 - Direct Inward Dialing <sup>2</sup>			
(1) First block of DID station numbers			
20 Stations		\$160.20	\$66.00
40 Stations		176.00	132.00
100 Stations	\$6,500.00	440.00	330.00
(2) Each additional block of DID station numbers			
20 Stations		160.20	66.00
40 Stations		176.00	132.00
100 Stations	1,100.00	160.20	200.00
b. Option 2 - Direct Inward Dialing <sup>3</sup>			
(1) First block of DID station numbers			
20 Stations		160.20	66.00
100 Stations <sup>4</sup>	6,500.00	440.00	330.00
100 Stations <sup>5</sup>		440.00	180.00
(2) Each additional block of DID station numbers			
20 Stations		160.20	66.00
100 Stations <sup>4</sup>	1,100.00	160.20	200.00
100 Stations <sup>5</sup>		160.20	150.00
(3) Trunk Termination,			
per trunk <sup>4</sup>			8.00
per trunk <sup>5</sup>			24.05

<sup>1</sup> In addition to the charges and rates for other services and facilities including charges and rates applicable to private branch exchange (PBX) trunk line service as shown in Rates of this section. When this service is provided from a foreign exchange, rates and charges for foreign exchange trunk lines and mileage rates as shown in Section 6, General Services will be applicable.

<sup>2</sup> This service may also be available on a discounted basis.

<sup>3</sup> Option 2 requires a Trunk Termination charge for each analog trunk arranged for DID service.

<sup>4</sup> Rates applicable to customers in exchanges listed in Section 5, Local Exchanges and Extended Service Areas, Sheet 2.

<sup>5</sup> Rates applicable to customers in exchanges listed in Section 5, Local Exchanges and Extended Service Areas, Sheet 3.

Effective: February 2, 2018

LOCAL EXCHANGE SERVICE

II. RATES AND CHARGES (Continued)

H. DIRECT INWARD DIALING SERVICE (DID) (Continued)

	<u>BTC</u>	<u>Nonrecurring Charge</u>	<u>Monthly Rate</u>	
1. Equipment arrangement in Company central office necessary to provide in-dialing from the exchange and message toll network directly to a dial switching equipment installed on the customer premises <sup>1</sup> (Continued)				
c. Telephone Answering Service (TAS)				
(1) First 100 direct inward dialing (DID) station numbers	\$6,500.00	\$440.00	\$135.00	
(2) Each additional 100 direct inward dialing (DID) station numbers	1,100.00	160.20	135.00	
2. Extended Basic Referral (See Special Conditions 1.F.2.)				(N)
Each increment of 5 DID Numbers or fraction thereof				
6 months	250.00			
12 months	450.00			
3. Direct Inward/Outward Dialing (DIOD) (Analog Services Only)				
(1) Trunk Termination Per Trunk <sup>1</sup>				
12 Month Term		95.00	8.00	
36 Month Term		95.00	5.00	

<sup>1</sup> These rates are in addition to the rates and charges for other services and facilities, including rates and charges applicable to Private Branch Exchange (PBX) trunk line service as shown in this section. When this service is provided from a foreign exchange, rates and charges for foreign exchange trunk lines and mileage rates in Section 6, General Services will be applicable. See Rates in this section for Direct Inward Dialing (DID). Option 1, DID service is not available with DIOD service.

Effective: November 1, 2020

LOCAL EXCHANGE SERVICE

II. RATES AND CHARGES (Continued)

I. PBX TRUNK DISCOUNT PRICING PLAN (DPP)\* (C)

A customer may subscribe to PBX Trunk service for a term length of 12, 24 or 36 months and receive discounted monthly rates as follows. The PBX Trunk Discount Pricing Plans are also available with discounts for DID Service.

	<u>Monthly Rate per trunk</u> <sup>1,3</sup>	<u>Monthly Rate per trunk</u> <sup>2,4</sup>
1. PBX Trunk Only		
a. Month-to-Month	5	5
b. 12-Month Term <sup>6,7</sup> 1+ Trunks	\$27.95	\$39.25
c. 24-Month Term <sup>6,7,8</sup> 1+ Trunks	25.95	37.00
d. 36-Month Term <sup>6,7</sup> 1+ Trunks	25.95	37.00

<sup>1</sup> Rates applicable to customers in exchanges listed in Section 5, Local Exchanges and Extended Service Areas, Sheet 2.

<sup>2</sup> Rates applicable to customers in exchanges listed in Section 5, Local Exchanges and Extended Service Areas, Sheet 3.

<sup>3</sup> The End User Common Line (EUCL) Charge in Frontier Operating Companies Tariff FCC No. 14, Section 13 is also applicable.

<sup>4</sup> The End User Common Line (EUCL) Charge in Frontier Operating Companies Tariff FCC No. 13, Section 4 is also applicable.

<sup>5</sup> See Section II.A.2 of this section for rates.

<sup>6</sup> The Central Office Activity charge from Section 3, Service Charges, is not applicable to the initial installation of new or additional lines.

<sup>7</sup> Plus Extended Area Service increments as identified in this Product Guide section.

<sup>8</sup> For the 24-month term, Plan 2 termination liability/early termination fees apply, as described in Section 2 of this Product Guide.

\* PBX and Business Line Discount Pricing Plan (DPP) is grandfathered and limited to all existing subscribers at their existing locations.

(N)  
(N)

Effective: November 1, 2020

LOCAL EXCHANGE SERVICE

II. RATES AND CHARGES (Continued)

I. PBX TRUNK DISCOUNT PRICING PLAN (DPP)\* (Continued)

(C)

Monthly  
Rate

2. DID Service with PBX Trunk <sup>1,2</sup>

a. Month-to-Month

Group of 20 Stations	\$66.00
Group of 40 Stations	132.00
Initial Group of 100 Stations	330.00
Additional Group(s) of 100 Stations	200.00

b. 12-Month Term<sup>3</sup>

Group of 20 Stations	66.00
Group of 40 Stations	132.00
Initial Group of 100 Stations	330.00
Additional Group(s) of 100 Stations	200.00

c. 36-Month Term<sup>3</sup>

Group of 20 Stations	60.00
Group of 40 Stations	120.00
Initial Group of 100 Stations	300.00
Additional Group(s) of 100 Stations	200.00

<sup>1</sup> Nonrecurring charges from Section 3, Service Charges, are applicable.

<sup>2</sup> These rates are only available if DID Service is ordered in conjunction with PBX Trunks as shown in the preceding.

<sup>3</sup> Plus Extended Area Service increments as identified in this Product Guide section.

\* PBX and Business Line Discount Pricing Plan (DPP) is grandfathered and limited to all existing subscribers at their existing locations.

(N)

(N)



Effective: November 1, 2020

LOCAL EXCHANGE SERVICE

II. RATES AND CHARGES (Continued)

I. PBX TRUNK DISCOUNT PRICING PLAN (DPP)\* (Continued)

(C)

3. PBX Trunk and IntraLATA Toll Discounts

Customers may elect to combine PBX Trunk Service (with or without DID Service) and IntraLata Toll Service and receive discounted monthly rates. This offer is composed of two elements: 1) the PBX Trunks (with or without DID Service), and 2) discounted IntraLATA Toll usage components. The rates in II.H.3(a) and (b) following apply only in conjunction with the discounted usage. The IntraLata Toll Service component in has a minimum monthly billing of \$25.00 per trunk.

	Monthly Rate <u>per trunk</u> <sup>1,2</sup>
(a) PBX Trunk Only Terms	
(1) 12-Month Term <sup>3, 4</sup>	
3-10 Trunks	\$26.50
11-50 Trunks	25.50
51+ Trunks	24.50
(2) 24-Month Term <sup>3, 4, 5</sup>	
3-10 Trunks	24.00
11-50 Trunks	23.00
51+ Trunks	22.00
(3) 36-Month Term <sup>3, 4</sup>	
3-10 Trunks	24.00
11-50 Trunks	23.00
51+ Trunks	22.00

<sup>1</sup> Rates applicable to customers in exchanges listed in Section 5, Local Exchanges and Extended Service Areas, Sheet 2.

<sup>2</sup> The End User Common Line (EUCL) Charge in Frontier Operating Companies Tariff FCC No. 14, Section 13 is also applicable.

<sup>3</sup> Nonrecurring charges from Section 3, Service Charges, are applicable.

<sup>4</sup> Plus Extended Area Service increments as identified in this Product Guide section.

<sup>5</sup> For the 24-month term, Plan 2 termination liability/early termination fees apply, as described in Section 2 of this Product Guide.

\* PBX and Business Line Discount Pricing Plan (DPP) is grandfathered and limited to all existing subscribers at their existing locations.

(N)  
(N)

Effective: November 1, 2020

LOCAL EXCHANGE SERVICE

II. RATES AND CHARGES (Continued)

I. PBX TRUNK DISCOUNT PRICING PLAN (DPP)\* (Continued)

(C)

3. PBX Trunk and IntraLATA Toll Discounts (Continued)

	<u>Monthly Rate</u>
(b) DID Service with PBX Trunk and IntraLATA Toll <sup>1,2</sup>	
(1) Month-to-Month	
Group of 20 Stations	\$66.00
Group of 40 Stations	132.00
Initial Group of 100 Stations	330.00
Additional Group(s) of 100 Stations	200.00
(2) 12-Month Term <sup>3</sup>	
Group of 20 Stations	60.00
Group of 40 Stations	120.00
Initial Group of 100 Stations	300.00
Additional Group(s) of 100 Stations	200.00
(3) 36-Month Term <sup>3</sup>	
Group of 20 Stations	45.00
Group of 40 Stations	90.00
Initial Group of 100 Stations	225.00
Additional Group(s) of 100 Stations	200.00

<sup>1</sup> Nonrecurring charges from Section 3, Service Charges, are applicable.

<sup>2</sup> These rates are available only if DID Service is ordered in conjunction with PBX Trunk Service and IntraLata Toll Service usage.

<sup>3</sup> Plus Extended Area Service increments as identified in this Product Guide section.

\* PBX and Business Line Discount Pricing Plan (DPP) is grandfathered and limited to all existing subscribers at their existing locations.

(N)  
 (N)

Effective: November 1, 2020

LOCAL EXCHANGE SERVICE

II. RATES AND CHARGES (Continued)

I. PBX TRUNK DISCOUNT PRICING PLAN (DPP)\* (Continued)

(C)

3. PBX Trunk and IntraLATA Toll Discounts (Continued)

(c) IntraLATA Toll Usage Rates <sup>1</sup>

	<u>Monthly Rate</u> <sup>2</sup>
(1) Month-to-Month	3
(2) 12-Month Term <sup>4</sup>	
- Less than 5000 minutes of use per month	25% Discount
- 5000 minutes or more per month	5
(3) 24 or 36-Month Term <sup>4</sup>	
- Less than 5000 minutes of use per month	\$0.0775
- 5000 minutes or more per month	5

<sup>1</sup> Nonrecurring charges from Section 3, Service Charges, are applicable.

<sup>2</sup> Minimum monthly usage charge of \$25.00 per PBX Trunk applies.

<sup>3</sup> Discount Calling Plan rates in Section 19, Frontier Calling Plans, apply.

<sup>4</sup> Plus Extended Area Service increments as identified in this Product Guide section.

<sup>5</sup> Rates will be negotiated on an Individual Case Basis (ICB).

\* PBX and Business Line Discount Pricing Plan (DPP) is grandfathered and limited to all existing subscribers at their existing locations.

(N)

(N)

Effective: June 1, 2023

LOCAL EXCHANGE SERVICE

II. RATES AND CHARGES (Continued)

J. BUSINESS LINE DISCOUNT PRICING PLAN (DPP)\*

A customer may subscribe to Business Line service for a term length of 12, 24 or 36 months and receive discounted monthly rates as follows. (See Special Conditions, Section I.H)

	<u>Monthly Rate per trunk</u> <sup>1,3</sup>	<u>Monthly Rate per trunk</u> <sup>2,4</sup>	
1. Business Line Only			
a. Month-to-Month	5	5	
b. 12-Month Term <sup>6,7,8</sup>			
1+ Lines	\$28.00	\$35.95	(l)
1+ Keyline or Multiline	--	35.95	(l)
c. 24-Month Term <sup>6,7,8,9</sup>			
1+ Lines	28.00	35.95	(l)
1+ Keyline or Multiline	--	35.95	(l)
d. 36-Month Term <sup>6,7,8</sup>			
1+ Lines	28.00	35.95	(l)
1+ Keyline or Multiline	--	35.95	(l)

<sup>1</sup> Rates applicable to customers in exchanges listed in Section 5, Local Exchanges and Extended Service Areas, Sheet 2.

<sup>2</sup> Rates applicable to customers in exchanges listed in Section 5, Local Exchanges and Extended Service Areas, Sheet 3.

<sup>3</sup> The End User Common Line (EUCL) Charge in Frontier Operating Companies Tariff FCC No. 14, Section 13 is also applicable.

<sup>4</sup> The End User Common Line (EUCL) Charge in Frontier Operating Companies Tariff FCC No. 13, Section 4 is also applicable.

<sup>5</sup> See Section II.A.1 of this section for rates.

<sup>6</sup> The Central Office Activity charge from Section 3, Service Charges, is not applicable to the initial installation of new or additional lines.

<sup>7</sup> Plus Extended Area Service increments as identified in this Product Guide section.

<sup>8</sup> Term Customers existing prior to 2/15/10 will continue to be billed at the old rate until the expiration of the existing term. As of 2/15/10, new term customers or lines added will be billed at the new rate.

<sup>9</sup> For the 24-month term, Plan 2 termination liability/early termination fees apply, as described in Section 2 of this Product Guide.

\* PBX and Business Line Discount Pricing Plan (DPP) is grandfathered and limited to all existing subscribers at their existing locations.

Effective: April 1, 2016

LOCAL EXCHANGE SERVICE

II. RATES AND CHARGES (Continued)

K. DIGITAL FORMAT TRUNKING <sup>1</sup>

	<u>Nonrecurring Charge</u>	<u>Monthly Rate</u>
1. DID/DOD trunk groups:		
a. First 24 trunks	\$1,486.00	\$110.00 <sup>2</sup>
b. Each additional 12 trunks	743.00	55.00 <sup>2</sup>
2. Channel bank:		
a. First 24 trunks	480.00	269.00 <sup>2</sup>
b. Each additional 12 trunk	240.00	181.00 <sup>2</sup>
3. Answer back supervision on DOD trunk		
a. Connection of 24 trunks	0.00	--
b. Monthly rate per trunk	--	10.10 <sup>2</sup>
4. Repeater	0.00	20.00 <sup>2</sup>

<sup>1</sup> This Service is applicable to customers in exchanges listed in Section 5, Sheet 3 of this Product Guide.

<sup>2</sup> Minimum service period of 60 months applies. Rates are in addition to applicable rates in this Schedule.

Effective: April 1, 2016

---

LOCAL EXCHANGES, EXTENDED SERVICE AREAS  
AND ZONE USAGE MEASUREMENT EXCHANGES AND SERVICE

TABLE OF CONTENTS

	<u>SHEET NO.</u>
LOCAL EXCHANGES, EXTENDED SERVICE AREAS	
I. GENERAL	1
Applicability	1
Territory	1
Frontier California Inc., Exchanges	2
within the former Contel serving territory	3
II. RATES AND CHARGES	4
III. SPECIAL CONDITIONS	4
A. Definitions	4
B. Local Calling Areas	5
C. Local Calling Areas – former Contel	24
VII. RATES AND CHARGES	5
ZONE USAGE MEASUREMENT SERVICE	
I. APPLICABILITY	36
II. TERRITORY	36
III. ZUM EXPANSION WAIVER	37
IV. SPECIAL CONDITIONS	38
V. RATES AND CHARGES	39

Effective: April 1, 2016

---

LOCAL EXCHANGES, EXTENDED SERVICE AREAS  
AND ZONE USAGE MEASUREMENT EXCHANGES AND SERVICE

I. GENERAL

APPLICABILITY

Applicable to calling within the local exchange and to extended area service (EAS) exchanges and district areas.

TERRITORY

Within exchanges and district areas as defined by maps as part of this Product Guide.

Effective: April 1, 2016

---

LOCAL EXCHANGES, EXTENDED SERVICE AREAS  
AND ZONE USAGE MEASUREMENT EXCHANGES AND SERVICE

I. GENERAL (Continued)

The following is a list of the exchanges within the Frontier California Inc. serving territory:

Alamitos	Fowler	Montecito
Aliso	Glendora	Morgan Hill
Alondra	Goleta	Morongo Valley
Arrowhead	Grant Grove	Mountain
Artesia	Guadalupe	Mugu
Azusa	Hemet -	Murrieta
Badger	Anza D.A.	Muscovy
Baldwin Park	Hemet D.A.	Newbury Park
Banning	Homeland D.A.	North Shore
Beaumont	San Jacinto D.A.	Norwalk
Bel Air	Homestead Valley	Novato
Bellflower	Huntington Beach	Oasis
Blossom Hill	Idyllwild	Ontario Airport
Bradley	Imperial	Ontario Main
Bundy West LA	Indio	Ontario South
Bushard	Joshua Tree	Oxnard
Calimesa	Kenwood	Pacific Palisades
Camarillo	La Habra	Palm Desert
Carpinteria	La Puente	Palm Springs East
Chino	La Verne	Palos Verdes
Claremont	Laguna Beach	Perris
Clark	Lake Hughes	Pico
Coachella	Lancaster	Pinyon
Conejo	La Quinta	Pomona
Covina	Las Positas	Quail Valley
Crestline	Lindsay	Quartz Hill
Cucamonga	Loma Linda	Rancho California
Del Amo	Lompoc	Rancho Mirage
Del Rey	Long Beach Main	Redhawk
Desert Center	Los Alamos	Redlands
Desert Heights	Los Serranos	Redondo
Desert Hot Springs	Malibu	Reedley
Desert Shores	Manhattan	Rio Hondo
Diamond Bar	Mantilla	Rolling Hills
Downey	Maplegrove	Rowland
Dunlap	Marine Palms	Salton City
Edgemont	Market	San Bernardino
El Nido	Marshall	Norton
El Rio	Martin L King	Waterman
Ellwood	Mecca	San Dimas
Elsinore Grand	Mentone	San Fernando -
Elsinore Main	Mesa	Granada Hills D.A.
Etiwanda	Miramonte	Pacoima D.A.
Florence	Monrovia	San Fernando D.A.
	Montebello	Sepulveda D.A.

D.A. District Area



Effective: April 1, 2016

---

LOCAL EXCHANGES, EXTENDED SERVICE AREAS  
AND ZONE USAGE MEASUREMENT EXCHANGES AND SERVICE

I. GENERAL (Continued)

The following is a list of the Frontier California Inc. exchanges within the former Contel serving territory:

Alpaugh	Garberville	Parkfield
Barstow -	(including Alderpoint Area)	Piercy
Barstow D.A.	Gilroy	Pinocreek
Yermo D.A.	Glennville	Randsburg
Benton Station	Hayfork	Ridgecrest
Berrenda Mesa	Hesperia	Ripon
Big Bear City	Hoopa	Robbins
Big Bear Lake	Independence	Running Springs
Big Pine	Inyokern	Sanger
Bishop	June Lake	San Joaquin
Boron	Kernville	San Miguel
Bridgeport	Knights Landing	Snelling
Buttonwillow	Lake Isabella	South Barstow
California City	Lathrop	Summit Valley
Calif Hot Springs	Laytonville	Taft
Cantua Creek	Lee Vining	Timber Cove -
Cazadero	Leggett	Sea Ranch D.A.
China Lake	Lemon Cove	Tivy Valley
Clements	Lenwood	Tranquility
Colfax -	Linden	Trona
Colfax D.A.	Lone Pine	Victorville -
Weimar D.A.	Lost Hills	Adelanto D.A.
Corcoran	Lucerne Valley	Apple Valley D.A.
Covelo	Mad River	Hesperia D.A.
Crowley Lake	Mammoth Lakes	Silver Lakes D.A.
Cuyama	Manteca	Victorville D.A.
Desert Knolls	Maricopa	Weaverville
Dos Palos	McFarland	Weldon
El Mirage	McKittrick	White Horn
Exeter	Newberry	Willow Creek
Farmington	North Edwards	Wrightwood -
Fellows	Olancha	Phelan D.A.
Fort Irwin	Orleans	Yermo
	Oro Loma	

D.A. District Area

Effective: April 1, 2016

---

LOCAL EXCHANGES, EXTENDED SERVICE AREAS  
AND ZONE USAGE MEASUREMENT EXCHANGES AND SERVICE

II. RATES AND CHARGES

- A. The Measured-Rate Service - Local Calling Rates, shown in Section 4, Local Exchange Service, in this Product Guide, are applicable to calls originating from within the Local Exchange and terminating at locations within the Local Exchange or within Zone 1 exchanges or Zone 2 exchanges.
- B. The Company will not charge for calls which originate within the local exchange from flat-rate, Basic Exchange Access Lines and which terminate within the Local Exchange, Zone 1, or Zone 2.
- C. Zone 3 rates are used to rate calls made within the 13-16 mile range. Zone 3 charges are applicable in lieu of, not in addition to, toll charges, for Zone 3 calling at the rates listed in Section 4, Local Exchange Service.

III. SPECIAL CONDITIONS

A. DEFINITIONS

District Area. A specific portion of an exchange area served by a particular central office or by a group of central offices common only to that portion, and for which there is a designated principal central office.

Extended Area Exchange. An exchange area other than a local exchange in which calls are terminated at rates and charges defined for local (non-toll) messages. (See Section 1, Definitions of Terms for "Extended Service.")

Local Calling Area. The local exchange or district area and respective Extended Area Exchanges.

Local Exchange (Serving Exchange). The telephone exchange area from which Basic Exchange Access Line Service is provided and in which the customer's premises is located. (See Section 1, Definitions of Terms for "Exchange" and "Exchange Area.")

Zone 1 Extended Area Exchanges from zero to eight miles of the Local (Serving) Exchange, where distance is measured by airline miles from the rate point of the Local Exchange to the rate points of the Extended Area Exchanges.

Zone 2 Extended Area Exchanges from 9 to 12 miles of the Local (Serving) Exchange, where distance is measured by airline miles from the rate point of the Local Exchange to the rate points of the Extended Area Exchanges.

Zone 3 Zone 3 rates are used to rate calls made within the 13-16 mile range. Zone 3 charges are applicable in lieu of, not in addition to, toll charges, for Zone 3 calling at the rates listed in Section 4, Local Exchange Service.

Effective: April 1, 2016

LOCAL EXCHANGES, EXTENDED SERVICE AREAS  
 AND ZONE USAGE MEASUREMENT EXCHANGES AND SERVICE

III. SPECIAL CONDITIONS (Continued)

B. LOCAL CALLING AREAS

Note: The letter "z" following the name of an Extended Area Exchange or District Area refers to ZUM Zone 2 exchanges.

<u>Local Exchanges and and District Areas</u>	<u>Extended Area Exchanges and District Area</u>		
	<u>Zone 1</u>	<u>Zone 2</u>	<u>Zone 3</u>
Alamitos	Cypress Huntington Beach Lakewood Long Beach Norwalk Westminster	Anaheim z Buena Park z Compton Compton D.A. z Fullerton z Garden Grove z San Pedro z	Brea Compton Gardena D.A. Downey La Habra Lomita Orange Pico Rivera Placentia Santa Anna Torrance Whittier
Arrowhead	Crestline Highland	Marshall Running Springs San Bernardino Summit Valley	
Azusa-Glendora	Claremont-San Dimas Covina-Baldwin Park Monrovia San Gabriel Canyon	Arcadia z Diamond Bar z El Monte z La Puente z Pomona z Sierra Madre z	Alhambra Brea Chino La Habra Ontario Pasadena Pasadena D.A. Pico Rivera Upland Whittier

Effective: August 29, 2016

LOCAL EXCHANGES, EXTENDED SERVICE AREAS  
 AND ZONE USAGE MEASUREMENT EXCHANGES AND SERVICE

III. SPECIAL CONDITIONS (Continued)

B. LOCAL CALLING AREAS (Continued)

<u>Local Exchanges and and District Areas</u>	<u>Extended Area Exchanges and District Area</u>		
	<u>Zone 1</u>	<u>Zone 2</u>	<u>Zone 3</u>
Badger	Grant Grove Miramonte - Pinehurst	Dunlap	
Banning- Beaumont		Calimesa Hemet San Jacinto D.A.	
Calimesa	Mentone Redlands	Banning-Beaumont	Colton Highland Lakeview-Nuevo Moreno San Bernardino
Camarillo	Conejo El Rio Newbury Park Oxnard Point Mugu Saticoy Somis	Moorpark z Santa Paula Thousand Oaks z Ventura East z	Simi Valley Ventura Central
Carpinteria	Santa Barbara		
Chino	Claremont-San Dimas Diamond Bar Ontario Placentia Pomona Upland Yorba Linda		Anaheim Azusa - Glendora Brea Corona Covina Baldwin Park Etiwanda Fullerton La Habra La Puente Mira Loma

Effective: April 1, 2016

LOCAL EXCHANGES, EXTENDED SERVICE AREAS  
 AND ZONE USAGE MEASUREMENT EXCHANGES AND SERVICE

III. SPECIAL CONDITIONS (Continued)

B. LOCAL CALLING AREAS (Continued)

<u>Local Exchanges and and District Areas</u>	<u>Extended Area Exchanges and District Area</u>		
	<u>Zone 1</u>	<u>Zone 2</u>	<u>Zone 3</u>
Claremont-San Dimas	Azusa-Glendora Chino Covina-Baldwin Park Diamond Bar Ontario Pomona Upland	San Gabriel Canyon z	Arcadia Etiwanda La Puente Monrovia
Conejo	Agoura Camarillo Moorpark Newbury Park Simi Valley Somis Thousand Oaks		El Rio Point Mugu Santa Paula
Covina-Baldwin Park	Azusa-Glendora Claremont-San Dimas Diamond Bar El Monte La Puente Monrovia	Arcadia z Brea z La Habra z Pico Rivera z Pomona z Sierra Madre z Whittier z	Alhambra Buena Park Chino Fullerton Montebello Norwalk Pasadena Pasadena D.A. Placentia San Gabriel Canyon Upland Yorba Linda
Crestline	Arrowhead Marshall Summit Valley San Bernardino	Highland Rialto Running Springs	

Effective: April 1, 2016

LOCAL EXCHANGES, EXTENDED SERVICE AREAS  
 AND ZONE USAGE MEASUREMENT EXCHANGES AND SERVICE

III. SPECIAL CONDITIONS (Continued)

B. LOCAL CALLING AREAS (Continued)

<u>Local Exchanges and and District Areas</u>	<u>Extended Area Exchanges and District Area</u>		
	<u>Zone 1</u>	<u>Zone 2</u>	<u>Zone 3</u>
Desert Center	Eagle Mountain		
Desert Hot Springs	Morongo Valley	Yucca Valley Palm Springs	
Diamond Bar	Brea Chino Claremont-San Dimas Covina-Baldwin Park La Puente Placentia Pomona	Azusa-Glendora z Fullerton z La Habra z Ontario z Upland z Yorba Linda z	Anaheim Arcadia Buena Park El Monte Monrovia Norwalk Pico Rivera San Gabriel Canyon Whittier
Downey	Compton Compton D.A. Lakewood Los Angeles D.A. 5 D.A. 6 Montebello Norwalk Pico Rivera Whittier	Alhambra z Buena Park z Compton Gardena D.A. z Cypress z El Monte z La Habra z Long Beach z Los Angeles D.A. 1 z D.A. 4 z D.A. 7 z D.A. 8 z D.A. 9 z D.A. 10 z D.A. 12 z	Alamitos Arcadia Brea Culver City Fullerton Glendale Hawthorne Inglewood La Puente Lomita Los Angeles D.A. 2 D.A. 3 D.A. 11 D.A. 13 D.A. 14 Monrovia Pasadena Pasadena D.A. Redondo Torrance Westminster

LOCAL EXCHANGES, EXTENDED SERVICE AREAS  
 AND ZONE USAGE MEASUREMENT EXCHANGES AND SERVICE

III. SPECIAL CONDITIONS (Continued)

B. LOCAL CALLING AREAS (Continued)

<u>Local Exchanges and and District Areas</u>	<u>Extended Area Exchanges and District Area</u>		
	<u>Zone 1</u>	<u>Zone 2</u>	<u>Zone 3</u>
Dunlap	Miramonte-Pinehurst Squaw Valley	Badger Grant Grove	
Eagle Mountain	Desert Center		
El Rio	Camarillo Oxnard Point Mugu Saticoy Somis Ventura East	Santa Paula Ventura Central z	Newbury Park Oakview
Elsinore	Sun City	Murrieta z Perris z	Lakeview-Nuevo Rancho Viejo Temecula Temescal Canyon Woodcrest
Etiwanda	Fontana Ontario Upland	Mira Loma z Rialto z	Arlington Chino Claremont-San Dimas Colton Marshall Pomona Riverside San Bernardino
Fowler	Del Rey Fresno Selma	Caruthers Parlier Kingsburg Sanger	
Grant Grove	Badger Miramonte - Pinehurst	Dunlap	
Guadalupe	Nipomo Santa Maria	Arroyo Grande	

LOCAL EXCHANGES, EXTENDED SERVICE AREAS  
 AND ZONE USAGE MEASUREMENT EXCHANGES AND SERVICE

III. SPECIAL CONDITIONS (Continued)

B. LOCAL CALLING AREAS (Continued)

<u>Local Exchanges and and District Areas</u>	<u>Extended Area Exchanges and District Area</u>		
	<u>Zone 1</u>	<u>Zone 2</u>	<u>Zone 3</u>
Hemet-Anza D.A.	Hemet Hemet D.A. Homeland D.A. Sage D.A. San Jacinto D.A.		
Hemet-Hemet D.A.	Hemet Anza D.A. Homeland D.A. Sage D.A. San Jacinto D.A.	Lakeview-Nuevo	
Hemet-Homeland D.A.	Hemet Anza D.A. Hemet D.A. Sage D.A. San Jacinto D.A. Lakeview- Nuevo	Perris Sun City	
Hemet-Sage D.A.	Hemet Anza D.A. Hemet D.A. Homeland D.A. San Jacinto D.A.		
Hemet-San Jacinto DA	Hemet Anza D.A. Hemet D.A. Homeland D.A. Sage D.A.	Banning-Beaumont Lakeview-Nuevo	
Hi Vista			
Homestead Valley	Yucca Valley	Joshua Tree	



Effective: April 1, 2016

LOCAL EXCHANGES, EXTENDED SERVICE AREAS  
AND ZONE USAGE MEASUREMENT EXCHANGES AND SERVICE

III. SPECIAL CONDITIONS (Continued)

B. LOCAL CALLING AREAS (Continued)

<u>Local Exchanges and and District Areas</u>	<u>Extended Area Exchanges and District Area</u>		
	<u>Zone 1</u>	<u>Zone 2</u>	<u>Zone 3</u>
Huntington Beach	Alamitos Garden Grove Newport Beach Santa Ana Westminster	Anaheim z Cypress z	Buena Park Fullerton Irvine Laguna Beach Lakewood Long Beach Orange
Idyllwild			
Indio		Palm Desert	
Joshua Tree	Yucca Valley	Homestead Valley Twentynine Palms	
Kenwood	Saint Helena Santa Rosa	Calistoga Sonoma Yountville	
Laguna Beach	Capistrano Valley Irvine Newport Beach Saddleback Valley		Huntington Beach Rancho Viejo Santa Ana Silverado Trabuco
La Habra	Brea Buena Park Fullerton La Puente Norwalk Pico Rivera Placentia Whittier	Anaheim Covina-Baldwin Park Cypress Diamond Bar Downey El Monte Garden Grove Montebello Yorba Linda	Alamitos Alhambra Arcadia Azusa-Glendora Chino Compton Compton D.A. Lakewood Los Angeles D.A. 5 Monrovia Orange Pomona Westminster

Effective: April 1, 2016

LOCAL EXCHANGES, EXTENDED SERVICE AREAS  
AND ZONE USAGE MEASUREMENT EXCHANGES AND SERVICE

III. SPECIAL CONDITIONS (Continued)

B. LOCAL CALLING AREAS (Continued)

<u>Local Exchanges and and District Areas</u>	<u>Extended Area Exchanges and District Area</u>		
	<u>Zone 1</u>	<u>Zone 2</u>	<u>Zone 3</u>
Lake Hughes		Palmdale Leona-Valley D.A.	
Lakeview-Nuevo	Hemet Hemet D.A. Homeland D.A. San Jacinto D.A. Perris	Moreno z Sun City z	Calimesa Elsinore Woodcrest
Lakewood	Alamitos Buena Park Compton Compton D.A. Cypress Downey Long Beach Norwalk	Compton Gardena D.A. z Fullerton z Garden Grove z Lomita z Los Angeles D.A. 6 z Pico Rivera z San Pedro z Torrance z Westminster z Whittier z	Anaheim Brea Hawthorne Huntington Beach Inglewood La Habra Los Angeles D.A. 5 D.A. 7 D.A. 8 D.A. 9 D.A. 12 Montebello Redondo
Lancaster	Palmdale Palmdale D.A.	Palmdale Leona Valley D.A.	
La Puente	Brea Covina-Baldwin Park Diamond Bar El Monte La Habra Pico Rivera Whittier	Alhambra z Arcadia z Azusa-Glendora z Buena Park z Fullerton z Monrovia z Montebello z Norwalk z Placentia z Pomona z	Anaheim Chino Claremont-San Dimas Cypress Downey Los Angeles D.A. 5 Pasadena Pasadena D.A. Sierra Madre Yorba Linda

Effective: April 1, 2016

LOCAL EXCHANGES, EXTENDED SERVICE AREAS  
 AND ZONE USAGE MEASUREMENT EXCHANGES AND SERVICE

III. SPECIAL CONDITIONS (Continued)

B. LOCAL CALLING AREAS (Continued)

<u>Local Exchanges and and District Areas</u>	<u>Extended Area Exchanges and District Area</u>		
	<u>Zone 1</u>	<u>Zone 2</u>	<u>Zone 3</u>
Lindsay	Exeter	Porterville	
Long Beach	Alamitos Compton Compton D.A. Lakewood Lomita Norwalk San Pedro	Compton Gardena D.A. z Cypress z Downey z Torrance z Westminster z	Buena Park Fullerton Garden Grove Hawthorne Huntington Beach Inglewood Los Angeles D.A. 6 D.A. 9 Pico Rivera Redondo Whittier
Los Alamos			
Los Gatos	Campbell San Jose South D.A. West D.A. Saratoga	Ben Lomond Sunnyvale z	Los Altos Mountain View San Jose North D.A.
Malibu	Agoura Canoga Park Santa Monica Santa Monica D.A.	Reseda z West Los Angeles z	Beverly Hills Culver City El Segundo Northridge Santa Monica Mar Vista D.A. Van Nuys
Marshall	Colton Crestline Highland Rialto San Bernardino	Arrowhead Fontana z Mentone z Redlands z Riverside z Running Springs Summit Valley	Etiwanda Mira Lema Moreno

Effective: April 1, 2016

LOCAL EXCHANGES, EXTENDED SERVICE AREAS  
 AND ZONE USAGE MEASUREMENT EXCHANGES AND SERVICE

III. SPECIAL CONDITIONS (Continued)

B. LOCAL CALLING AREAS (Continued)

<u>Local Exchanges and and District Areas</u>	<u>Extended Area Exchanges and District Area</u>		
	<u>Zone 1</u>	<u>Zone 2</u>	<u>Zone 3</u>
Meadowview			Rio Linda
Mentone	Calimesa Highland Redlands	Colton z Marshall z Running Springs San Bernardino z	Moreno Rialto Riverside
Miramonte-Pinehurst	Badger Dunlap Grant Grove	Squaw Valley	
Monrovia	Arcadia Azusa-Glendora Covina-Baldwin Park El Monte Pasadena Pasadena D.A. Sierra Madre	Alhambra z La Puente z Los Angeles D.A. 3 z Pasadena La Canada D.A. z Pico Rivera z	Claremont-San Dimas Diamond Bar Downey Glendale La Crescenta La Habra Los Angeles D.A. 1 D.A. 4 D.A. 5 Montebello Pomona San Gabriel Canyon Whittier
Moreno	Riverside Woodcrest	Arlington z Colton z Lakeview-Nuevo z Perris z Redlands z San Bernardino z	Calimesa Fontana Highland Marshall Mentone Mira Loma Rialto
Morgan Hill	San Martin	Gilroy	

Effective: April 1, 2016

LOCAL EXCHANGES, EXTENDED SERVICE AREAS  
 AND ZONE USAGE MEASUREMENT EXCHANGES AND SERVICE

III. SPECIAL CONDITIONS (Continued)

B. LOCAL CALLING AREAS (Continued)

<u>Local Exchanges and and District Areas</u>	<u>Extended Area Exchanges and District Area</u>		
	<u>Zone 1</u>	<u>Zone 2</u>	<u>Zone 3</u>
Morongo Valley	Desert Hot Springs Yucca Valley		
Murrieta	Temecula	Elsinore z Sun City z	
Newbury Park	Agoura Camarillo Conejo Moorpark Somis Thousand Oaks	Simi Valley z	El Rio Oxnard Point Mugu Saticoy
Norwalk	Alamitos Buena Park Compton Compton D.A. Cypress Downey La Habra Lakewood Long Beach Pico Rivera Whittier	Anaheim z Brea z El Monte z Fullerton z La Puente z Los Angeles D.A. 5 z D.A. 6 z Montebello z Westminster z	Alhambra Compton Gardena D.A. Covina-Baldwin Park Diamond Bar Garden Grove Lomita Los Angeles D.A. 1 D.A. 4 D.A. 7 D.A. 8 D.A. 9 D.A. 10 D.A. 12 Orange Placentia Torrance
Novato	Ignacio Nicasio San Rafael	Corte Madera Petaluma Main D.A. Swift D.A.	

Effective: April 1, 2016

LOCAL EXCHANGES, EXTENDED SERVICE AREAS  
AND ZONE USAGE MEASUREMENT EXCHANGES AND SERVICE

III. SPECIAL CONDITIONS (Continued)

B. LOCAL CALLING AREAS (Continued)

<u>Local Exchanges and and District Areas</u>	<u>Extended Area Exchanges and District Area</u>		
	<u>Zone 1</u>	<u>Zone 2</u>	<u>Zone 3</u>
Ontario	Chino Claremont-San Dimas Etiwanda Pomona Upland	Diamond Bar z Fontana z Mira Loma z	Arlington Azusa-Glendora Corona Rialto Yorba Linda
Oxnard	Camarillo El Rio Point Mugu Saticoy Somis Ventura East	Ventura Central z	Newbury Park Oakview
Palm Desert		Pinyon Indio	
Palm Springs	Desert Hot Springs		
Perris	Lakeview-Nuevo Sun City	Elsinore z Hemet Homeland D.A. Moreno z Woodcrest z	
Pico Rivera	Alhambra Downey El Monte La Habra La Puente Montebello Norwalk Whittier	Arcadia z Brea z Buena Park z Compton Compton D.A. z Covina-Baldwin Park z Lakewood z Los Angeles D.A.s 1, 4, 5 z D.A.s 6, 8 z Monrovia z Pasadena Pasadena D.A. z	Alamitos Anaheim Azusa-Glendora Compton Gardena D.A. Cypress Diamond Bar Fullerton Glendale Long Beach Los Angeles D.A.s 2, 3, 7, 9 D.A.s 10, 11, 12 Placentia Sierra Madre

Effective: April 1, 2016

LOCAL EXCHANGES, EXTENDED SERVICE AREAS  
 AND ZONE USAGE MEASUREMENT EXCHANGES AND SERVICE

III. SPECIAL CONDITIONS (Continued)

B. LOCAL CALLING AREAS (Continued)

<u>Local Exchanges and and District Areas</u>	<u>Extended Area Exchanges and District Area</u>		
	<u>Zone 1</u>	<u>Zone 2</u>	<u>Zone 3</u>
Pinyon		Palm Desert	
Point Mugu	Camarillo El Rio Oxnard Saticoy Somis	Ventura East z	Newbury Park Ventura Central
Pomona	Chino Claremont-San Dimas Diamond Bar Ontario Upland	Azusa-Glendora z Covina-Baldwin Park z La Puente z	Brea Etiwanda La Habra Monrovia Placentia San Gabriel Canyon Yorba Linda
Redlands	Calimesa Colton Highland Mentone	Marshall z Moreno z Rialto z Riverside z Running Springs San Bernardino z	Fontana Woodcrest
Redondo	Compton Gardena D.A. El Segundo Hawthorne Inglewood Lomita San Pedro Torrance	Compton Compton D.A. z Culver City z Los Angeles D.A. 8 z D.A. 9 z D.A. 12 z Santa Monica Mar Vista D.A. z	Beverly Hills Downey Lakewood Long Beach Los Angeles D.A.s 1, 5, 6, 7 D.A.s 10, 11, 13 Santa Monica Santa Monica D.A. West Los Angeles
Reedley	Dinuba Parlier	Del Rey Kingsburg Orange Cove Sanger Selma	

Effective: April 1, 2016

LOCAL EXCHANGES, EXTENDED SERVICE AREAS  
AND ZONE USAGE MEASUREMENT EXCHANGES AND SERVICE

III. SPECIAL CONDITIONS (Continued)

B. LOCAL CALLING AREAS (Continued)

<u>Local Exchanges and and District Areas</u>	<u>Extended Area Exchanges and District Area</u>		
	<u>Zone 1</u>	<u>Zone 2</u>	<u>Zone 3</u>
San Bernardino	Colton Fontana Highland Marshall Rialto	Arrowhead Crestline Mentone z Moreno z Redlands z Riverside z	Arlington Calimesa Etiwanda Mira Loma
San Fernando Granada Hills D.A.	Canoga Park Northridge Reseda San Fernando Pacoima D.A. San Fernando D.A. Sepulveda D.A. Sunland-Tujunga	Burbank Sun Valley D.A. z North Hollywood z Santa Clarita Newhall-Castaic D.A. Saugus- Canyon Country D.A. Van Nuys z	Burbank Burbank D.A. Los Angeles D.A. 14 Simi Valley West Los Angeles
San Fernando Pacoima D.A.	Burbank Sun Valley D.A. North Hollywood Northridge San Fernando Granada Hills D.A. San Fernando D.A. Sepulveda D.A. Sunland-Tujunga Van Nuys	Burbank Burbank D.A. z Canoga Park z Reseda z Santa Clarita Newhall-Castaic D.A. Saugus-Canyon Country D.A. z	Beverly Hills Glendale La Crescenta Los Angeles D.A. 2 D.A. 13 D.A. 14 Pasadena La Canada D.A, West Los Angeles
San Fernando San Fernando D.A.	Burbank Sun Valley D.A. Northridge San Fernando Granada Hills D.A. Pacoima D.A. Sepulveda D.A. Sunland-Tujunga	Burbank Burbank D.A. z Canoga Park z North Hollywood z Reseda z Santa Clarita Newhall-Castaic D.A. Saugus-Canyon Country D.A. z Van Nuys	Beverly Hills Glendale La Crescenta Los Angeles D.A. 2 D.A. 14 Pasadena La Canada



Effective: April 1, 2016

LOCAL EXCHANGES, EXTENDED SERVICE AREAS  
AND ZONE USAGE MEASUREMENT EXCHANGES AND SERVICE

III. SPECIAL CONDITIONS (Continued)

B. LOCAL CALLING AREAS (Continued)

<u>Local Exchanges and and District Areas</u>	<u>Extended Area Exchanges and District Area</u>		
	<u>Zone 1</u>	<u>Zone 2</u>	<u>Zone 3</u>
San Fernando Sepulveda D.A.	Burbank Sun Valley D.A. Canoga Park North Hollywood Northridge Reseda San Fernando Granada Hills D.A. Pacoima D.A. San Fernando D.A. Sunland-Tujunga Van Nuys	Beverly Hills z Burbank Burbank D.A. z Santa Clarita Newhall -Castaic D.A.	Culver City Glendale La Crescenta Los Angeles D.A. 2 D.A. 13 D.A. 14 Santa Monica Santa Monica D.A. Santa Clarita Saugus D.A. West Los Angeles
San Gabriel Canyon	Azusa-Glendora	Claremont-San Dimas z	Arcadia Covina-Baldwin Park Diamond Bar Monrovia Pomona Sierra Madre Upland
Santa Barbara		Carpinteria	
Santa Maria	Guadalupe Nipomo		
Santa Monica Mar Vista D. A.	Beverly Hills Culver City El Segundo Hawthorne Inglewood Los Angeles D.A.s 9, 11, 12, 13 Santa Monica Santa Monica D.A. West Los Angeles	Compton Gardena D.A. z Los Angeles D.A. 1 z D.A. 2 z D.A. 6 z D.A.s 7, 8, 10, 14 z Redondo z Van Nuys z	Burbank Burbank D.A, Sun Valley D.A. Compton Compton D.A. Glendale Lomita Los Angeles D.A.s 3, 4, 5 Malibu North Hollywood Reseda Torrance

Effective: December 2, 2021

LOCAL EXCHANGES, EXTENDED SERVICE AREAS  
 AND ZONE USAGE MEASUREMENT EXCHANGES AND SERVICE

III. SPECIAL CONDITIONS (Continued)

B. LOCAL CALLING AREAS (Continued)

<u>Local Exchanges and and District Areas</u>	<u>Extended Area Exchanges and District Area</u>		
	<u>Zone 1</u>	<u>Zone 2</u>	<u>Zone 3</u>
Santa Monica Santa Monica D.A.	Beverly Hills Canoga Park Culver City Malibu Reseda Santa Monica Mar Vista D.A. West Los Angeles	El Segundo z Hawthorne z Inglewood z Los Angeles D.A. 9 z D.A. 11 z D.A. 12 z D.A. 13 z D.A. 14 z Van Nuys z	Burbank Burbank D.A. Sun Valley D. A. Compton Gardena D.A. Glendale Los Angeles D.A.s 1, 2, 6 D.A.s 7, 8, 10 North Hollywood Northridge Redondo San Fernando Sepulveda D.A.
Santa Paula	Saticoy	Camarillo El Rio Fillmore Moorpark Somis	(N)
Sierra Madre	Alhambra Arcadia El Monte Monrovia Pasadena Pasadena D.A.	Azusa-Glendora z Covina-Baldwin Park z Glendale z La Crescenta z Los Angeles D.A. 3 z D.A. 4 z Montebello z Pasadena La Canada D.A. z	Burbank Burbank D.A. La Puente Los Angeles D.A.s 1, 2, 5 D.A.s 7, 10 Pico Rivera San Gabriel Canyon Whittier

Effective: April 1, 2016

LOCAL EXCHANGES, EXTENDED SERVICE AREAS  
AND ZONE USAGE MEASUREMENT EXCHANGES AND SERVICE

III. SPECIAL CONDITIONS (Continued)

B. LOCAL CALLING AREAS (Continued)

<u>Local Exchanges and and District Areas</u>	<u>Extended Area Exchanges and District Area</u>		
	<u>Zone 1</u>	<u>Zone 2</u>	<u>Zone 3</u>
Somis	Camarillo Conejo El Rio Moorpark Newbury Park Oxnard Point Mugu Saticoy	Santa Paula Thousand Oaks z	Simi Valley Ventura East
Squaw Valley	Dunlap Orange Cove	Miramonte-Pinehurst	
Sun City	Elsinore Perris	Hemet Homeland D.A. Lakeview-Nuevo z Murrieta z	Temecula
Sunland-Tujunga	Burbank Burbank D.A. Sun Valley D.A. Glendale La Crescenta North Hollywood Pasadena La Canada D.A. San Fernando Pacoima D.A. San Fernando D.A.	Los Angeles D.A. 2 z D.A. 3 z D.A. 14 z San Fernando Granada Hills D.A. z Sepulveda D.A. z Van Nuys z	Alhambra Beverly Hills Los Angeles D.A.s 1, 4, 7 D.A.s 10, 11, 13 Northridge Pasadena Pasadena D.A. Reseda Santa Clarita Newhall D.A. Saugus D.A.
Temecula	Murrieta		Elsinore Sun City
Thousand Oaks	Agoura Conejo Moorpark Newbury Park Simi Valley	Camarillo Somis	Canoga Park

Effective: April 1, 2016

LOCAL EXCHANGES, EXTENDED SERVICE AREAS  
 AND ZONE USAGE MEASUREMENT EXCHANGES AND SERVICE

III. SPECIAL CONDITIONS (Continued)

B. LOCAL CALLING AREAS (Continued)

<u>Local Exchanges and and District Areas</u>	<u>Extended Area Exchanges and District Area</u>		
	<u>Zone 1</u>	<u>Zone 2</u>	<u>Zone 3</u>
Twentynine Palms		Joshua Tree	
Upland	Chino Claremont-San Dimas Etiwanda Ontario Pomona	Diamond Bar	Azusa-Glendora Glendora-Baldwin Park Fontana Mira Lema San Gabriel Canyon
West Los Angeles	Beverly Hills Culver City Los Angeles D.A. 13 Reseda Santa Monica Mar Vista D.A. Santa Monica D.A. Van Nuys	El Segundo Hawthorne Inglewood Los Angeles D.A. 1 D.A. 2 D.A. 7 D.A. 8 D.A. 9 D.A. 10 D.A. 11 D.A. 12 D.A. 14 Malibu North Hollywood	Burbank Burbank D.A. Sun Valley D.A. Canoga Park Compton Gardena D.A. Los Angeles D.A.s 3, 4, 5, 6 Northridge Redondo San Fernando Granada Hills D.A. Pacoima D.A. Sepulveda D.A.
Westminster	Alamitos Anaheim Cypress Garden Grove Huntington Beach Santa Ana	Buena Park z Fullerton z Lakewood z Long Beach z Newport Beach z Norwalk z Orange z	Brea Downey Irvine La Habra Placentia Whittier Yorba Linda

Effective: April 1, 2016

LOCAL EXCHANGES, EXTENDED SERVICE AREAS  
 AND ZONE USAGE MEASUREMENT EXCHANGES AND SERVICE

III. SPECIAL CONDITIONS (Continued)

B. LOCAL CALLING AREAS (Continued)

<u>Local Exchanges and and District Areas</u>	<u>Extended Area Exchanges and District Area</u>		
	<u>Zone 1</u>	<u>Zone 2</u>	<u>Zone 3</u>
Whittier	Buena Park Downey El Monte La Habra La Puente Montebello Norwalk Pico Rivera	Alhambra z Arcadia z Brea z Compton Compton D.A. z Covina-Baldwin Park z Cypress z Fullerton z Lakewood z Los Angeles D.A. 5 z D.A. 6 z Placentia z	Alamitos Anaheim Azusa-Glendora Compton Gardena D.A. Diamond Bar Garden Grove Long Beach Los Angeles D.A.s 1, 3, 4 D.A.s 7, 8, 9, 10 Monrovia Pasadena Pasadena D.A. Sierra Madre Westminster Yorba Linda
Yucca Valley	Homestead Valley Joshua Tree Morongo Valley	Desert Hot Springs	

Effective: April 1, 2016

---

LOCAL EXCHANGES, EXTENDED SERVICE AREAS  
AND ZONE USAGE MEASUREMENT EXCHANGES AND SERVICE

III. SPECIAL CONDITIONS (Continued)

B. LOCAL CALLING AREAS - former Contel (Continued)

Local Exchanges and District Areas

Extended Area Exchanges and District Areas

Alpaugh

Alpaugh  
Pixley (Pac Bell) <sup>1</sup>

Barstow  
Barstow D.A.

Barstow  
Barstow D.A.  
Yermo D.A.  
Lenwood

Yermo D.A.

Barstow  
Barstow D.A.  
Yermo D.A.  
Lenwood  
Newberry

Benton Station

Benton Station

Berrenda Mesa

Berrenda Mesa

Big Bear City

Big Bear City  
Big Bear Lake

Big Bear Lake

Big Bear City  
Big Bear Lake  
Running Springs

Big Pine <sup>2</sup>

Big Pine  
Bishop <sup>2</sup>

<sup>1</sup> ELCA routes effective as of 6-1-91.

<sup>2</sup> EAS

Effective: April 1, 2016

---

LOCAL EXCHANGES, EXTENDED SERVICE AREAS  
AND ZONE USAGE MEASUREMENT EXCHANGES AND SERVICE

III. SPECIAL CONDITIONS (Continued)

B. LOCAL CALLING AREAS - former Contel (Continued)

<u>Local Exchanges and District Areas</u>	<u>Extended Area Exchanges and District Areas</u>
Bishop <sup>1</sup>	Big Pine <sup>1</sup> Bishop Pine Creek <sup>1</sup>
Boron	Boron
Bridgeport	Bridgeport
Buttonwillow	Buttonwillow McKittrick
California City	California City
California Hot Springs	California Hot Springs Glennville
Cazadero	Cazadero Forestville (Pac Bell) <sup>2</sup> Guerneville (Pac Bell) <sup>2</sup> Monte Rio (Pac Bell) <sup>2</sup> Timber Cove

<sup>1</sup> EAS

<sup>2</sup> ELCA routes effective as of 6-1-91.

Effective: April 1, 2016

---

LOCAL EXCHANGES, EXTENDED SERVICE AREAS  
AND ZONE USAGE MEASUREMENT EXCHANGES AND SERVICE

III. SPECIAL CONDITIONS (Continued)

B. LOCAL CALLING AREAS - former Contel (Continued)

Local Exchanges and District Areas

Extended Area Exchanges and District Areas

Clements

Clements  
Galt (Pac Bell) <sup>1</sup>  
Herald (Pac Bell) <sup>1</sup>  
Linden  
Lockeford (Pac Bell) <sup>1</sup>  
Lodi (Pac Bell) <sup>1</sup>  
Wallace (Pac Bell) <sup>1</sup>

Colfax  
Colfax D.A.

Alta (Pac Bell) <sup>1</sup>  
Foresthill (Foresthill) <sup>1</sup>  
Grass Valley Main D.A. (Pac Bell) <sup>1</sup>  
Grass Valley South D.A. (Pac Bell) <sup>1</sup>  
Nevada City (Pac Bell) <sup>1</sup>  
Colfax  
Colfax D.A.  
Weimar D.A.

Weimar D.A.

Auburn Main D.A. (Pac Bell) <sup>1</sup>  
Auburn North D.A. (Pac Bell) <sup>1</sup>  
Foresthill (Foresthill) <sup>1</sup>  
Georgetown (Pac Bell) <sup>1</sup>  
Grass Valley South D.A. (Pac Bell) <sup>1</sup>  
Colfax  
Colfax D.A.  
Weimar D.A.

Corcoran

Corcoran

Covelo

Covelo

Crowley Lake

Crowley Lake  
Mammoth Lakes

<sup>1</sup> ELCA routes effective as of 6-1-91.



Effective: April 1, 2016

LOCAL EXCHANGES, EXTENDED SERVICE AREAS  
 AND ZONE USAGE MEASUREMENT EXCHANGES AND SERVICE

III. SPECIAL CONDITIONS (Continued)

B. LOCAL CALLING AREAS - former Contel (Continued)

<u>Local Exchanges and District Areas</u>	<u>Extended Area exchanges and District Areas</u>	<u>Zone 3</u>
Cuyama	Cuyama	
Dos Palos	Dos Palos	
El Mirage	El Mirage Victorville - Adelanto D.A.	Victorville Victorville D.A. Wrightwood Phelan D.A.
Exeter	Exeter Lemon Cove Lindsay <sup>2</sup> Visalia (Pac Bell) <sup>2</sup> Woodlake (Pac Bell) <sup>2</sup>	
Farmington	Escalon (Pac Bell) <sup>2</sup> Farmington Milton (Pac Bell) <sup>2</sup> Linden	
Fort Irwin	Fort Irwin	
Garberville (including Alderpoint Area)	Garberville Miranda (Pac Bell) <sup>2</sup> Piercy Whitethorn	
Gilroy	Gilroy Morgan Hill <sup>2</sup> San Martin (Pac Bell) <sup>2</sup> Watsonville (Pac Bell) <sup>2</sup>	

<sup>1</sup> EAS

<sup>2</sup> ELCA routes effective as of 6-1-91.

Effective: April 1, 2016

---

LOCAL EXCHANGES, EXTENDED SERVICE AREAS  
AND ZONE USAGE MEASUREMENT EXCHANGES AND SERVICE

III. SPECIAL CONDITIONS (Continued)

B. LOCAL CALLING AREAS - former Contel (Continued)

Local Exchanges and District Areas

Extended Area exchanges and District Areas

Glennville

California Hot Springs  
Glennville

Hayfork

Hayfork

Hoopla

Hoopla  
Willow Creek

Independence

Independence

Inyokern

Inyokern  
Ridgecrest

June Lake

June Lake  
Lee Vining  
Mammoth Lakes

Kernville

Kernville  
Lake Isabella  
Weldon

Knights Landing

Knights Landing  
Nicolaus (Pac Bell) <sup>1</sup>  
Robbins  
Woodland (Pac Bell) <sup>1</sup>

Lake Isabella

Kernville  
Lake Isabella  
Weldon

<sup>1</sup> ELCA routes effective as of 6-1-91.

Effective: April 1, 2016

LOCAL EXCHANGES, EXTENDED SERVICE AREAS  
 AND ZONE USAGE MEASUREMENT EXCHANGES AND SERVICE

III. SPECIAL CONDITIONS (Continued)

B. LOCAL CALLING AREAS - former Contel (Continued)

<u>Local Exchanges and District Areas</u>	<u>Extended Area exchanges and District Areas</u>	<u>Zone 3</u>
Laytonville	Laytonville	
Sherwood Ranch D.A.	Laytonville	Sherwood Ranch D.A.
	Willits <sup>1</sup>	Sherwood Ranch D.A.
Lee Vining	Lee Vining June Lake	
Leggett	Leggett Piercy	
Lemon Cove	Exeter Lemon Cove Three Rivers (Pac Bell) <sup>2</sup> Woodlake (Pac Bell) <sup>2</sup>	
Lenwood	Barstow - Barstow D.A. Barstow - Yermo D.A. Lenwood	
Linden	Linden Lockeford (Pac Bell) <sup>2</sup> Stockton (Pac Bell) <sup>2</sup> Farmington Clements	
Lone Pine <sup>1</sup>	Lone Pine Olancho <sup>1</sup>	
Lost Hills	Lost Hills	
Lucerne Valley	Lucerne Valley	Victorville Apple Valley D.A.

<sup>1</sup> One-way EAS from Sherwood Ranch DA to Willits.

<sup>2</sup> ELCA routes effective as of 6-1-91.

Effective: April 1, 2016

---

LOCAL EXCHANGES, EXTENDED SERVICE AREAS  
AND ZONE USAGE MEASUREMENT EXCHANGES AND SERVICE

III. SPECIAL CONDITIONS (Continued)

B. LOCAL CALLING AREAS - former Contel (Continued)

<u>Local Exchanges and District Areas</u>	<u>Extended Area exchanges and District Areas</u>
Mad River	Mad River
Mammoth Lakes	Crowley Lake June Lake Mammoth Lakes
Manteca	Manteca Ripon Stockton (Pac Bell) <sup>1</sup> Tracy (Pac Bell) <sup>1</sup>
McFarland	Delano (Pac Bell) <sup>1</sup> McFarland Wasco (Pac Bell) <sup>1</sup>
McKittrick	Buttonwillow McKittrick
Newberry	Barstow Yermo D.A. Newberry
Olancho <sup>2</sup>	Lone Pine <sup>2</sup> Olancho
Orleans	Orleans Somes Bar (Siskiyou) <sup>1</sup>

<sup>1</sup> ELCA routes effective as of 6-1-91.

Effective: April 1, 2016

---

LOCAL EXCHANGES, EXTENDED SERVICE AREAS  
AND ZONE USAGE MEASUREMENT EXCHANGES AND SERVICE

III. SPECIAL CONDITIONS (Continued)

B. LOCAL CALLING AREAS - former Contel (Continued)

<u>Local Exchanges and District Areas</u>	<u>Extended Area exchanges and District Areas</u>
Parkfield	Parkfield
Piercy	Garberville Whitethorn Leggett Piercy
Pine Creek <sup>1</sup>	Bishop <sup>1</sup> Pine Creek
Randsburg	Randsburg
Ridgecrest	Inyokern Ridgecrest
Ripon	Escalon (Pac Bell) <sup>2</sup> Manteca Modesto (Pac Bell) <sup>2</sup> Ripon River Bank (Pac Bell) <sup>2</sup>
Robbins	Knights Landing Nicolaus (Pac Bell) <sup>2</sup> Pleasant Grove (Pac Bell) <sup>2</sup> Robbins

<sup>1</sup> EAS

<sup>2</sup> ELCA routes effective as of 6-1-91.

Effective: April 1, 2016

---

LOCAL EXCHANGES, EXTENDED SERVICE AREAS  
AND ZONE USAGE MEASUREMENT EXCHANGES AND SERVICE

III. SPECIAL CONDITIONS (Continued)

B. LOCAL CALLING AREAS - former Contel (Continued)

Local Exchanges and District Areas

Extended Area exchanges and District Areas

Running Springs

Arrowhead <sup>1</sup>  
Big Bear Lake  
Crestline <sup>1</sup>  
Highland (Pac Bell) <sup>1</sup>  
Marshall <sup>1</sup>  
Mentone  
Redlands <sup>1</sup>  
Running Springs

Sanger

Clovis (Pac Bell) <sup>1</sup>  
Del Rey (Pac Bell) <sup>1</sup>  
Fowler <sup>1</sup>  
Fresno (Pac Bell)  
Parlier (Pac Bell) <sup>1</sup>  
Reedley <sup>1</sup>  
Sanger  
Selma (Pac Bell) <sup>1</sup>  
Tivy Valley

San Joaquin (incl.  
Cantua Creek and Tranquility)

Kerman (Kerman) <sup>1</sup>  
San Joaquin

San Miguel

Bradley (Pac Bell) <sup>1</sup>  
Paso Robles (Pac Bell) <sup>1</sup>  
San Miguel

Snelling

Hornitos (Hornitos) <sup>1</sup>  
Snelling

<sup>1</sup> ELCA routes effective as of 6-1-91.

Effective: April 1, 2016

---

LOCAL EXCHANGES, EXTENDED SERVICE AREAS  
AND ZONE USAGE MEASUREMENT EXCHANGES AND SERVICE

III. SPECIAL CONDITIONS (Continued)

B. LOCAL CALLING AREAS - former Contel (Continued)

<u>Local Exchanges and District Areas</u>	<u>Extended Area exchanges and District Areas</u>	<u>Zone 3</u>
Summit Valley	Victorville Hesperia D.A. Arrowhead <sup>1</sup> Crestline <sup>1</sup> Marshall (Pac Bell) Summit Valley	Victorville Apple Valley D.A. Victorville D.A. Wrightwood Phelan D.A.
Taft	Taft	
Timbercove	Cazadero Sea Ranch D.A. Timbercove	
Sea Ranch DA	Annapolis (Pac Bell) Gualala (Pac Bell) Timbercove (including Sea Ranch DA)	
Tivy Valley	Clovis (Pac Bell) <sup>1</sup> Del Rey (Pac Bell) <sup>1</sup> Fresno (Pac Bell) <sup>1</sup> Parlier (Pac Bell) <sup>1</sup> Sanger Tivy Valley	
Trona	Ridgecrest <sup>2</sup> Trona	

<sup>1</sup> ELCA routes effective as of 6-1-91.

<sup>2</sup> EAS

Effective: April 1, 2016

---

LOCAL EXCHANGES, EXTENDED SERVICE AREAS  
AND ZONE USAGE MEASUREMENT EXCHANGES AND SERVICE

III. SPECIAL CONDITIONS (Continued)

B. LOCAL CALLING AREAS - former Contel (Continued)

<u>Local Exchanges and District Areas</u>	<u>Extended Area exchanges and District Areas</u>	<u>Zone 3</u>
Victorville Adelanto D.A.	Victorville Adelanto D.A. Apple Valley D.A. Hesperia D.A. Victorville D.A. El Mirage	Wrightwood Phelan D.A.
Apple Valley D.A.	Victorville Adelanto D.A. Apple Valley D.A. Hesperia D.A. Victorville D.A.	Summit Valley Lucerne Valley
Hesperia D.A.	Victorville Adelanto D.A. Apple Valley D.A. Hesperia D.A. Victorville D.A. Summit Valley	Wrightwood Phelan D.A.
Victorville D.A.	Victorville Adelanto D.A. Apple Valley D.A. Hesperia D.A. Victorville D.A.	El Mirage Summit Valley



Effective: April 1, 2016

LOCAL EXCHANGES, EXTENDED SERVICE AREAS  
 AND ZONE USAGE MEASUREMENT EXCHANGES AND SERVICE

III. SPECIAL CONDITIONS (Continued)

B. LOCAL CALLING AREAS - former Contel (Continued)

<u>Local Exchanges and District Areas</u>	<u>Extended Area exchanges and District Areas</u>	<u>Zone 3</u>
Weaverville	Lewiston (Pac Bell) <sup>1</sup> Weaverville	
Weldon	Lake Isabella Weldon	Kernville
Whitethorn	Garberville Piercy Whitethorn	
Willow Creek	Hoopa Willow Creek	
Wrightwood	Big Butte (Pac Bell) <sup>1</sup> Wrightwood	
Phelan D.A.	Big Butte (Pac Bell) <sup>1</sup> Wrightwood Phelan D.A.	El Mirage Summit Valley Victorville Adelanto D.A. Hesperia D.A.

<sup>1</sup> ELCA routes effective as of 6-1-91.

Effective: April 1, 2016

---

LOCAL EXCHANGES, EXTENDED SERVICE AREAS  
AND ZONE USAGE MEASUREMENT EXCHANGES AND SERVICE

ZONE USAGE MEASUREMENT SERVICE

I. APPLICABILITY

Applicable from the exchanges and district areas listed below in connection with all classes, types and grades of extended service, including Foreign Exchange Service and Mobile Telephone Service.

Services excluded from this offering are Semipublic and Public Telephone Service.

Alamitos	Lakewood	Redondo
Azusa-Glendora	La Puente	San Bernardino
Calimesa	Long Beach	San Fernando
Camarillo	Los Gatos	Granada Hills D.A.
Chino	Malibu	Pacoima D.A.
Claremont-San Dimas	Marshall	San Fernando D.A.
Conejo	Meadowview	Sepulveda D.A.
Covina-Baldwin Park	Mentone	San Gabriel Canyon
Diamond Bar	Monrovia	Santa Monica
Downey	Moreno	Mar Vista D.A.
El Rio	Murrieta	Santa Monica D.A.
Elsinore	Newbury Park	Sierra Madre
Etiwanda	Norwalk	Somis
Huntington Beach	Ontario	Sun City
Laguna Beach	Oxnard	Sunland-Tujunga
La Habra	Perris	Temecula
Lakeview-Nuevo	Pico Rivera	Thousand Oaks
	Pomona	Upland
	Point Mugu	West Los Angeles
	Redlands	Westminster
		Whittier

II. TERRITORY

Within the territory as set forth under Zone Calling Routes under RATES in this Section.

Effective: April 1, 2016

---

LOCAL EXCHANGES, EXTENDED SERVICE AREAS  
AND ZONE USAGE MEASUREMENT EXCHANGES AND SERVICE

ZONE USAGE MEASUREMENT SERVICE (Continued)

III. ZUM EXPANSION WAIVER

In accordance with CPUC Decision 90-06-016 effective December 10, 1990. The Company will bill rates which were in effect prior to the Decision for distance-sensitive private line-like service rate elements and secretarial lines which are affected by boundary reconfigurations associated with ZUM expansion and are in-service prior to the implementation date of December 10, 1990. This deviation will be in effect for a maximum of 2 years from the effective date of Advice 5284.

Changes which will void this deviation prior to the expiration date are:

- (1) number changes,
- (2) TAS and Alarm Company name changes,
- (3) CPUC ordered rate structure changes or adjustments to rate elements, and
- (4) any changes other than those listed above which physically changes the service.

The deviation will affect customers who subscribe to intraexchange/ interexchange private line private line-like services or secretarial line service in the following exchanges:

Calimesa, Camarillo, Conejo, El Rio, Elsinore, Hemet, Lakeview-Nuevo, Marshall, Mentone, Moreno, Murrieta, Newbury Park, Oxnard, Perris, Point Mugu, Redlands, San Bernardino, San Fernando, Somis, Sun City, Temecula, and Thousand Oaks.

Effective: April 1, 2016

---

LOCAL EXCHANGES, EXTENDED SERVICE AREAS  
AND ZONE USAGE MEASUREMENT EXCHANGES AND SERVICE

ZONE USAGE MEASUREMENT SERVICE (Continued)

IV. SPECIAL CONDITIONS

- A. The Flat and Measured rates referred to under V. Rates and Charges following, are for basic exchange access service as set forth in the General Exchange Tariff, Schedule No. A-1 for Residence and Section 4 of this Product Guide for Business, and are applicable for service from the exchanges listed in the APPLICABILITY section, which indicates the local service areas.
- B. The rates referred to in V. Rates and Charges C., following, are applicable in addition to the rates for Basic Exchange Access Service for all calls from the exchanges and district areas listed below:

<u>Los Angeles County Area</u>		<u>San Francisco - East Bay and Sacramento Areas</u>
Alamitos	San Fernando	Los Gatos
Azusa-Glendora	Granada Hills DA	Meadowview
Covina-Baldwin Park	Pacoima DA	
Downey	San Fernando DA	
La Habra	Sepulveda DA	
La Puente	San Gabriel Canyon	
Lakewood	Santa Monica	
Long Beach	Mar Vista DA	
Malibu	Santa Monica DA	
Monrovia	Sierra Madre	
Norwalk	Sunland-Tujunga	
Pico Rivera	West Los Angeles	
Redondo	Whittier	

Orange, Riverside, San Bernardino & Ventura County Areas

Calimesa	Moreno	Thousand Oaks
Camarillo	Murrieta	Upland
Chino	Newbury Park	Westminster
Claremont-San Dimas	Ontario	
Conejo	Oxnard	
Diamond Bar	Perris	
El Rio	Pomona	
Elsinore	Point Mugu	
Etiwanda	Redlands	
Huntington Beach	San Bernardino	
Laguna Beach	Somis	
Lakeview-Nuevo	Sun City	
Marshall	Temecula	
Mentone		

Effective: April 1, 2016

---

LOCAL EXCHANGES, EXTENDED SERVICE AREAS  
AND ZONE USAGE MEASUREMENT EXCHANGES AND SERVICE

ZONE USAGE MEASUREMENT SERVICE (Continued)

IV. SPECIAL CONDITIONS (Continued)

C. Zone Calling Charges apply to:

1. Sent-paid messages dialed and completed by the customer from a residence or business telephone service without the assistance of a Company operator.
2. Sent-paid messages placed with the assistance of a Company operator where:
  - a. Dial completion facilities are not available;
  - b. equipment or circuit conditions cause unsuccessful dial attempts;
  - c. the customer identifies himself as being handicapped and unable to dial;
  - d. the Company operator must identify the calling number where automatic recording equipment is not available.

D. With one exception, for messages other than those described above, the Rates and Charges, and Special Conditions applicable are as provided in Section 28 of this Product Guide.

Exception: For messages to any Information Access Services, Rates and Special Conditions applicable are in Section 17 of this Product Guide.

V. RATES AND CHARGES

A. Zone Usage Measurement (ZUM)

1. Zone 1 and 2

The local calling rate component is used to rate calls made within the 0-12 mile range (Zone 1 is 0-8 miles and Zone 2 is 9-12 miles (see the General Exchange Tariff, Schedule No. A-1 for Residence and Section 4 of this Product Guide for Business for Local Calling Rates and Section 31 for Local Calling Areas).

2. Zone 3

Zone 3 rates are used to rate calls made within the 13-16 mile range. Zone 3 charges are applicable in lieu of, not in addition to, toll charges, for Zone 3 calling at the rates listed in Rates C.2.b., following.

B. Flat and Measured Rates

General Exchange Tariff, Schedule No. A-1 for Residence and Section 4 of this Product Guide for Business rates and allowances are applicable for basic exchange access service (See Special Conditions A and B).

Effective: April 1, 2016

LOCAL EXCHANGES, EXTENDED SERVICE AREAS  
AND ZONE USAGE MEASUREMENT EXCHANGES AND SERVICE

ZONE USAGE MEASUREMENT SERVICE (Continued)

V. RATES AND CHARGES (Continued)

C. Zone Calling

Day, Evening, Night and Weekend rates are applicable to all calls based on the initial and additional minutes used at the rates below.

1. Zone 1 and 2  
Included in local calling area as defined in A.1., preceding.

2. Zone 3

a. Rate Periods

	<u>Hours</u>	<u>Rate</u>
Monday thru Friday	8:00 am to 5:00 <sup>1</sup> pm 5:00 pm to 11:00 <sup>1</sup> pm 11:00 pm to 8:00 <sup>1</sup> am	Day Evening Night
Saturday and Sunday	All	

b. Rates

	Initial Minute <sup>2, 3</sup>		Additional Minute <sup>2, 3</sup>	
	<u>Business</u>	<u>Residence</u>	<u>Business</u>	<u>Residence</u>
<u>Day</u> <sup>4</sup>	\$0.100	\$0.100	\$0.090	\$0.040
<u>Evening</u> <sup>4</sup>	0.100	0.070	0.090	0.028
<u>Night and Weekend</u> <sup>4</sup>	0.100	0.040	0.090	0.016

<sup>1</sup> To, but not including.

<sup>2</sup> Or portion thereof.

<sup>3</sup> Fractional amounts are rounded to the nearest cent.

<sup>4</sup> Zone Calling rates are applicable during the time of day when the conversation takes place. In cases where a message extends beyond one rate period, the appropriate rate treatment as specified applies to the respective periods of conversation.

Effective: July 24, 2019

---

GENERAL SERVICES

TABLE OF CONTENTS

	<u>SHEET NO.</u>
Automated Information Service (AIS)	1
Customer Name and Address (CNA) Service	3
Inside Wire Maintenance (IWM) Service	4
Billable Repair Service	6
Home Voice Mail/Voice Messaging Service	8
Business Traffic Study Service	17
Foreign Exchange Service	19
Exchange Services Mileage Rates	27
High Voltage Protection Service – Grandfathered as of September 5, 2012	34
Miscellaneous Billing Service	39
I. Multiple Bill Copy Service (MBCS)	39
II. Call Screening	40
III. Special Billing Number Service	41
IV. Level Bill Plan (LBP)	42
Telephone Answering Service	43
Supplemental Services	53
Interexchange Receiving Service	55
Private Line Services and Channels	56
Convenience Fee	57
Vacation Get Away Service	58

Effective: April 1, 2016

---

GENERAL SERVICES

AUTOMATED INFORMATION SERVICE (AIS)

I. SPECIAL CONDITIONS

A. Automated Information Service (AIS)

Automated Information Service (AIS) is an automated attendant service which allows a subscriber's callers to interact with information through a touch tone telephone. The caller is able to navigate through one or several menus to choose their desired destination, which may include a subscriber's line, an individual extension, a voice mailbox or a prerecorded voice narrative.

The AIS service group includes three options: Automated Attendant, Overflow Attendant and Information Bulletin Board. Automated Attendant and Overflow Attendant answer incoming calls and present the caller with a menu of choices which allow the caller to self direct the call to its destination. Information Bulletin Board delivers to the caller commonly desired information selected by the caller through their touch tone telephone.

AIS Ports

AIS Basic Port - Shared ports for use by multiple customers.

AIS Enhanced Port - Shared ports for use by multiple customers with additional backup. It is recommended that AIS Enhanced Ports be used with Automated Attendant and Overflow Attendant features.

B. EZ-AIS

EZ-AIS is a single level menu Automated Information Service which limits the customer to a smaller, standardized set of auto attendant features and options.



Effective: April 1, 2016

GENERAL SERVICES

AUTOMATED INFORMATION SERVICES (AIS) (Continued)

II. RATES AND CHARGES

A.	Nonrecurring Charges	<u>Unit</u>	Nonrecurring <u>Charge</u> <sup>1</sup>
1.	Automated Information Services (AIS) <sup>2</sup>		
	Basic Port, per customer	each	\$495.00
	Enhanced Port, per customer	each	495.00
	Change Charge, per customer, per order		
	1st change	each	50.00
	Each additional change	each	35.00
2.	EZ-Automated Information Services (AIS) <sup>2</sup>		
	Basic Port, per customer	each	195.00
	Enhanced Port, per customer	each	195.00
B.	Monthly Rates	<u>Unit</u>	Monthly <u>Rate</u>
1.	Automated Information Services (AIS) <sup>2</sup>		
	Basic Port		
	Month-to-month	each	\$60.00
	12 month agreement	each	55.00
	36 month agreement	each	50.00
	Enhanced Port		
	Month-to-month	each	70.00
	12 month agreement	each	60.00
	36 month agreement	each	50.00
2.	EZ-Automated Information Services (AIS) <sup>2</sup>		
	Basic Port		
	Month-to-month	each	60.00
	12 month agreement	each	55.00
	36 month agreement	each	50.00
	Enhanced Port		
	Month-to-month	each	70.00
	12 month agreement	each	60.00
	36 month agreement	each	50.00

<sup>1</sup> Section 3 Service Charges are not applicable.

<sup>2</sup> Business customers only.

Effective: April 1, 2016

---

GENERAL SERVICES

CUSTOMER NAME AND ADDRESS (CNA) SERVICE

I. SPECIAL CONDITIONS

Customer Name and Address (CNA) Service allows a customer to request a name and/or address by providing a telephone number to the directory assistance operator. Customers have access to name and address information associated with local and/or national listings included in Frontier's directory assistance database. Information is not provided for non-published listings. Charges will apply in the event that no information is available.

CNA is available for both residential and business customers where technically feasible.

CNA may be accessed by dialing 411. The customer will receive a maximum of two listings per call; for example:

- two NDA numbers, or
- one NDA number and one CNA listing, or
- two CNA listings

Operator assisted calls to CNA will be assessed the applicable rate for CNA in addition to the applicable operator assisted station message service charge, as set forth in Section 20, Operator Services.

CNA does not provide a call allowance.

CNA will not be provided on WATS telephone numbers.

The Company assumes no responsibility or liability for any error in the information furnished. The customer shall indemnify the Company and hold it free and harmless of and from any and all claims, demands or damages that shall arise from the use of the service.

II. RATES AND CHARGES

Nonrecurring Charges <sup>1</sup>

	<u>Unit</u>	<u>Nonrecurring Charge</u> <sup>2</sup>
Per call	each	\$0.95

<sup>1</sup> Operator assisted calls to CNA will be assessed the applicable operator assisted station message service charge, as set forth in Section 20, Operator Services.

<sup>2</sup> Section 3 Service Charges are not applicable.

Effective: April 1, 2016

---

GENERAL SERVICES

INSIDE WIRE MAINTENANCE (IWM) SERVICE

I. SPECIAL CONDITIONS

- A. Inside Wire Maintenance (IWM) Service is available to residence and business customers subscribing to individual-line Basic Exchange Access Line Service, and Centrex customers.

Inside Wire Maintenance (IWM) includes the following:

Determining source of trouble.

Repair or replacement of defective, damaged, or improperly operating standard inside wire or standard jacks.

Inside Wire Maintenance (IWM) excludes the following:

Repair of marine, recreational vehicle (RV), and construction trailer jacks and wiring.

Repair of damage due to natural disasters.

Repair or replacement of non-industry-standard wire and jacks.

Repair of damage due to malicious activity.

Repair of complex inside wiring or jacks associated with complex inside wiring, WATS, or data services.

Repair of customer-provided equipment.

Lines of customers who subscribe to Inside Wire Maintenance (IWM) or who receive Billable Repair Service may be disconnected for nonpayment of rates and charges for either service.

The services provided in accordance with this guide do not include removal, installation, or re-installation of inside wire nor do they include installation of additional wire or jacks.

An Inside Wire Maintenance (IWM) agreement does not imply resolution of a problem within any specific time period.

Customers who subscribe to Inside Wire Maintenance (IWM) must subscribe on a per-line basis for full coverage.

Customers who subscribe to Inside Wire Maintenance (IWM) with the initial order for telephone service, will receive immediate inside wire maintenance coverage.

Customers who subscribe to Inside Wire Maintenance (IWM) after service has been initiated, will have a thirty (30) day waiting period before inside wire maintenance coverage becomes effective. <sup>1</sup>

<sup>1</sup> Does not apply to the Inside Wire Maintenance (IWM) Alternative Offer.

Effective: March 17, 2019

GENERAL SERVICES

INSIDE WIRE MAINTENANCE (IWM) SERVICE (Continued)

I. SPECIAL CONDITIONS (Continued)

B. Inside Wire Maintenance (IWM) Alternative Offer

Inside Wire Maintenance (IWM) Alternative Offer is available to residence customers. The IWM Alternative Offer provides immediate repair coverage at the time of purchase, and covers pre-existing conditions.

All other special conditions for the standard IWM plan will apply.

The customer must maintain the plan for a 12 month period. An early termination fee will be billed if the customer cancels the plan prior to the end of the 12 month period.

A nonrecurring charge will be billed at the time of purchase.

Monthly charges are the same as for the standard IWM plan.

II. RATES AND CHARGES

A. Inside Wire Maintenance (IWM)

	<u>Monthly Rate</u>	
Residence service Each Line	\$10.50	(l)
Business service, Each Line	12.00	(l)
Centrex Service, Each Line	12.00	(l)

B. Inside Wire Maintenance (IWM) Alternative Offer

	<u>Monthly Rate</u>	<u>Nonrecurring Charge</u>	
Initial charge for immediate coverage		\$39.99	(l)
Each Line, with a 12-month commitment			
Residence service	\$10.50		(l)
Business service	\$12.00		(l)
Charge for cancellation prior to the end of the 12-month period			
Early termination fee		50.00	

Effective: April 1, 2016

---

GENERAL SERVICES

BILLABLE REPAIR SERVICE

I. SPECIAL CONDITIONS

The charges for Billable Repair Service commence after a customer accepts the charges, as specified in this section, and the Company's technician is on the premises. Prior to the commencement of actual repair, the customer must be notified that the trouble is on the customer's side of the LLDP and must be advised of competitive alternatives.

Billable Repair Service will be provided to residence and business customers subscribing to individual-line Basic Exchange Access Line Services, WATS, 800, or Private Line and Special Access Service or to any combination of those services.

II. RATES AND CHARGES

A. Simple Inside Wire Billable Repair Service - Residence

	<u>Nonrecurring Charge</u>
Repair Charge <sup>1</sup>	
First hour, or less, of billable time required to dispatch employee, locate trouble, and complete repair	
Weekdays (Weekdays, except holidays, 8:00 a.m. to 5:00 p.m.)	\$85.00
After Hours (Weekdays 5:00 p.m. to 8:00 a.m. and Saturdays, except holidays)	127.00
Sundays and Holidays	170.00
Each additional 15 minutes, or less, of billable time required to locate trouble and complete repair	
Weekdays (Weekdays, except holidays, 8:00 a.m. to 5:00 p.m.)	21.00
After Hours (Weekdays 5:00 p.m. to 8:00 a.m. and Saturdays, except holidays)	31.00
Sundays and Holidays	42.00

<sup>1</sup> Includes minor materials, i.e. wire, jacks, and material used directly on wire and jacks.

Effective: April 1, 2016

---

GENERAL SERVICES

BILLABLE REPAIR SERVICE (Continued)

II. RATES AND CHARGES (Continued)

B. Simple Inside Wire Billable Repair Service – Business

	<u>Nonrecurring Charge</u>
Repair Charge <sup>1</sup>	
First hour, or less, of billable time required to dispatch employee, locate trouble, and complete repair	
Weekdays (Weekdays, except holidays, 8:00 a.m. to 5:00 p.m.)	\$150.00
After Hours (Weekdays 5:00 p.m. to 8:00 a.m. and Saturdays, except holidays)	190.00
Sundays and Holidays	225.00
Each additional 15 minutes, or less, of billable time required to locate trouble and complete repair	
Weekdays (Weekdays, except holidays, 8:00 a.m. to 5:00 p.m.)	27.50
After Hours (Weekdays 5:00 p.m. to 8:00 a.m. and Saturdays, except holidays)	40.00
Sundays and Holidays	55.00

<sup>1</sup> Includes minor materials, i.e. wire, jacks, and material used directly on wire and jacks.

Effective: August 31, 2016

---

GENERAL SERVICES

HOME VOICE MAIL/VOICE MESSAGING SERVICE

I. SPECIAL CONDITIONS

- A. Home Voice Mail. A voice message service for residential customers which includes call answering, reminder, and wake-up capabilities (wake-up capability is available to residence customers only).

**Home Voice Mail – Standard** includes a voice message service for residential customers, which includes call answering with 30 message capacity <sup>1</sup>, plus Reminder Messages and Wake Up Service. (T)

(T)

The nonrecurring charge associated with establishing a voice mail box is not applicable for customers who choose to upgrade any existing Voice Mail Service to a higher level service.

- B. Voice Messaging Service. Electronic voice mailbox service for single line and multi-line business customers which provides call answering, ability for users to store messages for play back later, and other features.

Answer Only Mailbox. Message boxes for subscribers who do not want messages to be taken from callers but who want to leave a message for callers. This service is available with either five or three minute increments in which subscribers may record these messages to callers.

BASIC Mailbox. A basic-feature mailbox sold exclusively to business customers with single-line(s), non-Centrex service. BASIC Mailbox offers a simplified pattern of prompts as an alternative to the Standard Mailbox with full-features. Optional features available with the BASIC Mailbox are: Customer Controllable Ringing (CCR), Audible Ring Burst (ARB) and Visual Message Waiting Indicator (MWI).

The nonrecurring charge associated with establishing a voice messaging mailbox is not applicable for customers who choose to upgrade any existing Voice Messaging Service to a higher level service.

Customers with an existing Frontier Voice Messaging Standard Mailbox who choose to downgrade their mailbox service to the BASIC Mailbox service will be charged the standard one-time, nonrecurring charge for the BASIC Mailbox.

Enhanced Mailbox. An enhancement to a message box which will permit mail to be delivered up to 365 days into the future, a five-minute message length, ten group lists, and a thirty-day period for undelivered messages.

Extension Message Box. A message storage service which permits Frontier Voice Messaging customers to have as many as 98 secondary message boxes. The secondary message boxes must be set by Frontier.

Message Waiting Indicator Visual – Frequency Shift Keying (MWIV-FSK) is a switch generated signal. The MWIV-FSK signal will activate a light on specially designed Customer Premise Equipment (CPE). The light informs users that they have a voice message(s) waiting. Frontier Voice Messaging receives a message for storage.

<sup>1</sup> Where equipment and facilities permit.

Effective: April 1, 2016

---

GENERAL SERVICES

HOME VOICE MAIL/VOICE MESSAGING SERVICE (Continued)

I. SPECIAL CONDITIONS (Continued)

B. Voice Messaging Service (Continued)

Message Notification –

Special Delivery. A service which calls a number programmed by the customer and announces that a voice mail message has been deposited. The customer inputs a passcode and the voice mail message is played.

Where facilities permit, the residence or business customer may also elect to have the Company send and receive instructions relating to the customer's voicemails; e.g. send a message waiting notification, send a copy of the voicemail, delete the voicemail, to a non-Company device that is technically capable of accepting and sending those instructions.

C. Home Voice Mail/Frontier Voice Messaging Optional Features. Ring Count Change (RCC) and Audible Ring Burst (ARB) are network enhanced features available with both Home Voice Mail and Voice Messaging Services.

Ring Count Change (RCC) allows the Home Voice Mail customer to choose the number of times the phone will ring before forwarding to the Home Voice Mail mailbox. The customer can choose between 1 and 9 rings, and the number of rings can be changed at the customer's discretion via access codes. This replaces the default forwarding, which is based on seconds, not actual rings (on an average the phone will ring between 3 and 5 times).

Audible Ring Burst (ARB) allows the customer to receive a splash ring every 15 minutes when a message is waiting. The customer can turn this on or off as desired by an access code. This feature gives an audible reminder that a message is waiting.

D. OnePoint Voice Mail (OPVM) Service. An electronic voice mailbox service for residential and business customers that provides the customer with the ability to utilize a single voice mailbox for wireline voice messages.

1. OnePoint Voice Mail (OPVM) Service includes the features of Home Voice Mail - Standard (except with 50 message capacity), plus eight (8) Individual Mail Boxes, Group Lists, Personal Receptionist, Special Delivery, Ring Count Change (RCC)(formerly Customer Controlled Ringing [CCR]) and Multiple Number Service.



Effective: April 1, 2016

---

GENERAL SERVICES

HOME VOICE MAIL/VOICE MESSAGING SERVICE (Continued)

I. SPECIAL CONDITIONS (Continued)

D. OnePoint Voice Mail (OPVM) Service (Continued)

2. Conditions

OnePoint Voice Mail (OPVM) Service allows up to four additional Frontier or non-Frontier wireline telephone numbers (Multiple Number Service), in addition to the main telephone number, to forward calls into a single mailbox.

In order to forward calls to the OPVM mailbox, the four additional numbers must subscribe to the Call Forwarding feature with the Busy Line Don't Answer function.<sup>1</sup> Customers who desire a non-Frontier number as one of the four additional numbers must contact the provider of that number to order the Call Forwarding feature.

The applicable call-forwarding or tol charges may apply for each completed call made between the additional line from which the call is forwarded and the OPVM mailbox to which the call is forwarded. For customers with Measured-Rate Service, Local Calling Rate charges from Section 4, Local Exchange Service, will apply each time the Voice Mailbox is accessed, and for each call forwarded to the Mailbox. Long distance charges may apply when a customer accesses the Voice Mailbox from a location outside the local calling area.

OnePoint Voice Mail (OPVM) Service is available where equipment and facilities permit, in accordance with the terms and special conditions specified in this Product Guide. Non-Frontier wireline numbers may or may not work as additional numbers, as the data received from the provider may not be compatible with Frontier's network.

The nonrecurring charge associated with establishing OPVM Service will be waived for customers who choose to upgrade from any existing Home Voice Mail or Voice Messaging Service to OPVM.

3. Feature Descriptions

Group List. A feature that allows customers to create a list with the mailbox numbers of people to whom they send frequent broadcast-type messages. The customer records a message from the OnePoint Voice Mail (OPVM) mailbox or a Voice Messaging Services mailbox and then sends it to a specified group list. This feature is available with Voice Messaging Service and OnePoint Voice Mail (OPVM) Service.

Individual Mail Box. A message storage service which permits customers to set up as many as eight secondary message boxes. Available in One Point Voice Mail for residential customers. Available as Extension Message Boxes to business customers.

Multiple Number Service. A feature of OnePoint Voice Mail (OPVM) Service that allows up to four additional Frontier or non-Frontier wireline telephone numbers, in addition to the main telephone number, to forward calls into a single mailbox.

Personal Receptionist. A service which permits a caller who has reached the OnePoint Voice Mail (OPVM) mailbox to press "zero" and be transferred to a live answer number.

<sup>1</sup> See Section 7, Custom Calling Services for Call Forwarding rates.

Effective: March 1, 2023

GENERAL SERVICES

HOME VOICE MAIL/VOICE MESSAGING SERVICE (Continued)

II. RATES AND CHARGES

A. Home Voice Mail

	<u>Unit</u>	<u>Nonrecurring Charge</u> <sup>1</sup>	
Home Voice Mail Packages			
Home Voice Mail - Standard	each box	\$10.00	
Home Voice Mail Optional Features			
- Ring Count Change (RCC)	each line	--	
- Audible Ring Burst (ARB)	each line	--	
- Spanish Prompt	each line	--	
OnePoint Voice Mail (OPVM) Service	each box	15.00	
	<u>Unit</u>	<u>Monthly Rate</u>	
Home Voice Mail Packages <sup>2,3</sup>			
Home Voice Mail - Standard	each box	12.49 <sup>4</sup>	(l)
Home Voice Mail Optional Features			
- Ring Count Change (RCC)	each line	1.00	
- Audible Ring Burst (ARB)	each line	1.50	
- Spanish Prompt	each line	--	
OnePoint Voice Mail (OPVM) Service <sup>2,3</sup>	each box	13.49 <sup>4</sup>	(l)
Message Waiting Indication			
Visual – FSK	each box	.50	

<sup>1</sup> Service Charges from Section 3 are not applicable.

<sup>2</sup> For customers with Measured-Rate Service, Local Calling Rate charges from Section 4 of this Product Guide, Local Exchange Service will apply each time the Voice Mailbox is accessed, and for each call forwarded to the Mailbox.

<sup>3</sup> Long distance charges may apply when a customer accesses the Voice Mailbox from a location outside the local calling area.

<sup>4</sup> To be implemented on a full bill period basis on or after March 21, 2015.

Effective: April 1, 2016

GENERAL SERVICES

HOME VOICE MAIL/VOICE MESSAGING SERVICE (Continued)

II. RATES AND CHARGES (Continued)

B. Voice Messaging Service

	<u>Unit</u>	<u>Nonrecurring Charge <sup>1</sup></u>
Remote Call Notification	each box	--
Ring Count Change (RCC)	each line	--
Audible Ring Burst (ARB)	each line	--
BASIC Mailbox		
No term plan	each order	\$15.00
12-month term	each order	15.00
Message Boxes - Centrex Lines		
No term plan	each box	2.50
12-month term plan		
from 1 to 50 boxes	each box	2.50
from 51 to 250 boxes	each box	2.50
36-month term plan		
from 1 to 50 boxes	each box	2.50
from 51 to 250 boxes	each box	2.50
from 251 to 600 boxes	each box	2.50
more than 600 boxes	each box	2.50
60-month term plan		
from 51 to 100 boxes	each box	2.50
from 101 to 250 boxes	each box	2.50
from 251 to 600 boxes	each box	2.50
more than 600 boxes	each box	2.50
84-month term plan		
from 51 to 100 boxes	each box	2.50
from 101 to 250 boxes	each box	2.50
from 251 to 600 boxes	each box	2.50
more than 600 boxes	each box	2.50
Message Boxes - All Other Lines		
No term plan	each order	15.00
12-month term plan	each order	N/A
36-month term plan	each order	N/A

<sup>1</sup> Section 3 Service Charges are not applicable.

GENERAL SERVICES

HOME VOICE MAIL/VOICE MESSAGING SERVICE (Continued)

II. RATES AND CHARGES (Continued)

B. Voice Messaging Service (Continued)

	<u>Unit</u>	<u>Nonrecurring Charge <sup>1</sup></u>
Extension Message Boxes		
First Message Box		
Centrex Lines		
No Term plan	each box	\$2.50
12 month term plan		
from 1 to 50 boxes	each box	2.50
from 51 to 250 boxes	each box	2.50
36 month term plan		
from 1 to 50 boxes	each box	2.50
from 51 to 250 boxes	each box	2.50
All Other Lines		
No Term plan	each order	15.00
12 month term plan		
from 1 to 50 boxes	each order	0.00
from 51 to 250 boxes	each order	0.00
36-month term plan		
from 1 to 50 boxes	each order	0.00
from 51 to 250 boxes	each order	0.00
Additional Message Box		
Centrex Lines	each box	2.50
All Other Lines	each order	15.00
Enhanced Mailboxes		
with 50 Message Capacity	each box	--
with 100 Message Capacity	each box	--
Centrex Enhanced Mailboxes		
with 50 Capacity	each box	--
with 100 Capacity	each box	--
Answering Mailboxes		
Centrex Lines		
Five (5) Minute Box	each box	2.50
Three (3) Minute Box	each box	2.50
All Other Lines		
Five (5) Minute Box	each order	15.00
Three (3) Minute Box	each order	15.00
Message Waiting Indicator Visual-FSK	each line	--

<sup>1</sup> Section 3 Service Charges are not applicable.

Effective: April 1, 2016

GENERAL SERVICES

HOME VOICE MAIL/VOICE MESSAGING SERVICE (Continued)

II. RATES AND CHARGES (Continued)

B. Voice Messaging Service (Continued)

	<u>Unit</u>	<u>Monthly Rate</u>
Remote Call Notification	each box	\$3.00
Ring Count Change (RCC)	each line	1.00
Audible Ring Burst (ARB)	each line	1.50
BASIC Mailbox <sup>1, 2, 3</sup>		
No term plan	each box	10.70
12-month term plan <sup>4</sup>	each box	4.95
Message Boxes - Centrex Lines <sup>1, 2, 3</sup>		
No term plan	each box	16.75
12-month term plan <sup>4</sup>		
from 1 to 50 boxes	each box	12.00
from 51 to 250 boxes	each box	9.50
36-month term plan <sup>4</sup>		
from 1 to 50 boxes	each box	10.00
from 51 to 250 boxes	each box	8.75
from 251 to 600 boxes	each box	7.50
more than 600 boxes	each box	6.75
60-month term plan		
from 51 to 100 boxes	each box	8.25
from 101 to 250 boxes	each box	7.25
from 251 to 600 boxes	each box	6.25
more than 600 boxes	each box	5.75
84-month term plan		
from 51 to 100 boxes	each box	6.95
from 101 to 250 boxes	each box	5.95
from 251 to 600 boxes	each box	5.50
more than 600 boxes	each box	5.25
Message Boxes - All Other Lines <sup>1, 2, 3</sup>		
No term plan	each box	16.75
12-month term plan <sup>4</sup>	each box	12.00
36-month term plan <sup>4</sup>	each box	10.00

<sup>1</sup> See Section 2 of this Product Guide for termination liability terms and conditions.

<sup>2</sup> For customers with Measured-Rate Service, Local Calling Rate charges from Section 4 of this Product Guide will apply each time the Voice Mailbox is accessed, and for each call forwarded to the Mailbox.

<sup>3</sup> Long distance charges may apply when a customer accesses the Voice Mailbox from a location outside the local calling area.

<sup>4</sup> Termination liability will be waived for customers on a 12- or 36-month term plan who convert to Unlimited Local and Toll Usage for Business with Feature Package Two or Three. For rates, terms and conditions see Section 8, Bundled/Packaged Services.

Effective: April 1, 2016

GENERAL SERVICES

HOME VOICE MAIL/VOICE MESSAGING SERVICE (Continued)

II. RATES AND CHARGES (Continued)

B. Voice Messaging Service (Continued)

	<u>Unit</u>	<u>Monthly Rate</u>
Extension Message Boxes <sup>1, 2, 3</sup>		
First Message Box		
Centrex Lines		
No term plan	each box	\$21.70
12 month term plan		
from 1 to 50 boxes	each box	17.95
36 month term plan		
from 1 to 50 boxes	each box	16.95
All Other Lines		
No Term plan	each box	21.70
12-month term plan		
from 1 to 50 boxes	each box	17.95
36-month term plan		
from 1 to 50 boxes	each box	16.95
Additional Message Box		
Centrex Lines	each box	8.75
All Other Lines	each box	8.75
Enhanced Mailboxes		
with 50 Message Capacity	each box	4.00
with 100 Message Capacity	each box	15.00
Centrex Enhanced Mailboxes		
with 50 Message Capacity	each box	4.00
with 100 Message Capacity	each box	15.00

<sup>1</sup> See Section 2 of this Product Guide for termination liability terms and conditions.

<sup>2</sup> For customers with Measured-Rate Service, Local Calling Rate charges from Section 4 of this Product Guide will apply each time the Voice Mailbox is accessed, and for each call forwarded to the Mailbox.

<sup>3</sup> Long distance charges may apply when a customer accesses the Voice Mailbox from a location outside the local calling area.

Effective: April 1, 2016

GENERAL SERVICES

HOME VOICE MAIL/VOICE MESSAGING SERVICE (Continued)

II. RATES AND CHARGES (Continued)

B. Voice Messaging Service (Continued)

	<u>Unit</u>	<u>Monthly Rate</u>
Answering Mailboxes <sup>1,2</sup>		
Centrex Lines		
Five (5) Minute Box	each box	\$21.90
Three (3) Minute Box	each box	9.95
All Other Lines		
Five (5) Minute Box	each box	21.90
Three (3) Minute Box	each box	9.95
Message Waiting Indicator Visual-FSK	each line	.50

C. OnePoint Voice Mail (OPVM) Service

	<u>Unit</u>	<u>Nonrecurring Charge <sup>3</sup></u>
Single Line	each order	\$20.00
Hunt Group	each order	20.00
	<u>Unit</u>	<u>Monthly Rate</u>
Single Line	each box	\$18.75
Hunt Group	each box	25.75

<sup>1</sup> For customers with Measured-Rate Service, Local Calling Rate charges from Section 4 of this Product Guide, Local Exchange Service will apply each time the Voice Mailbox is accessed, and for each call forwarded to the Mailbox.

<sup>2</sup> Long distance charges may apply when a customer accesses the Voice Mailbox from a location outside the local calling area.

<sup>3</sup> Section 3 Service Charges are not applicable.

---

GENERAL SERVICES

BUSINESS TRAFFIC STUDY SERVICE

I. GENERAL

Business Traffic Study Service provides business customers with a performance report of call capacity for originating and terminating traffic on access lines or hunt groups. The traffic study report enables customers to determine how many calls terminate successfully and the number of calls that reach a station busy condition.<sup>1</sup> The reports will be provided verbally and, upon request from the customer, an electronic copy will be provided. The Company provides these reports along with a recommendation of required lines to accommodate the studied call traffic, based on industry standards for call traffic handling. Recommendations are based on traffic engineering tables and are not guaranteed to address all traffic situations which may be encountered by the customer.

II. SPECIAL CONDITIONS

- A. Business Traffic Study Service is available only to business customers.
- B. Calls must be carried by Frontier and billed by, or on behalf of, Frontier to the customer requesting the study.
- C. Traffic studies are performed on the customer's access lines or hunt groups with local exchange numbers.
- D. Customers with access lines or hunt groups at more than one location will be assessed the Service Establishment Charge for traffic studies for each location.
- E. Traffic study reports are provided verbally on a weekly, bi-weekly or monthly basis. The monthly rate is determined by the number of traffic study reports provided within a 4-week billing cycle. Upon request by the customer, an electronic copy will be provided.
- F. Only one Service Establishment Charge will be applicable when a customer requests an Initial Traffic Study and Subsequent Traffic Studies at the same time. The monthly reporting rate will then begin after the first week of the study.
- G. Data provided in the traffic study report may vary due to technical parameters determined by the central office switch technology.
- H. For the setup of each additional Business Traffic Study Report, per customer location, per calendar year, the Service Establishment Charge applies in addition to the monthly rate.

<sup>1</sup> Traffic report studies provided from a DMS 100 central office switch will not include the number of calls that reach a busy condition on individual access lines.



GENERAL SERVICES

BUSINESS TRAFFIC STUDY SERVICE (Continued)

II. SPECIAL CONDITIONS (Continued)

- I. A telephone number is defined as a non-hunting business line, a multiline hunt group, or a DID/DOD/PRI or other hunt group.
- J. Studies cannot be performed on toll-free or pay-per-call type telephone numbers.
- K. A separate traffic study report is required for each of the following:

Individual Access Line	Centrex Communications System Group
Multiline Hunt Group	Remote Call Forwarding
PBX Trunk Group	Centrex Single Line Station
DID Trunk Group	Centrex Multiline Hunt Group
DOD Trunk Group	Centrex Attendant
ISDN BRI	Centrex Features - RCF/ACD
ISDN PRI Trunk Group	Access Network Register(s) / Business Groups
DCS Trunk Group	or other trunk groups
FTR Business Pack Group	

III. RATES AND CHARGES

	<u>Nonrecurring Charge</u>	<u>Monthly Rate</u>
A. Service Establishment Charge, <sup>1</sup> Per Traffic Study Request, Per Customer Location		
1. Initial One-Week Traffic Study, Per Calendar Year	\$50.00	
2. Each Subsequent Traffic Study	50.00 <sup>2</sup>	
B. Traffic Study Reports, Per Access Line or Hunt Group, Per Calendar Year		
1. Initial One-Week Study Report, Per Calendar Year		--
1. Each Subsequent Study Report, Per 4-Week Billing Cycle		
Weekly Reporting (4 Reports)		\$80.00
Bi-Weekly Reporting (2 Reports)		60.00
Monthly Reporting (1 Report)		40.00

<sup>1</sup> Initial Service Establishment Charge includes a one-week report at no charge.

<sup>2</sup> See Special Conditions.

Effective: April 1, 2016

---

GENERAL SERVICES

FOREIGN EXCHANGE SERVICE

I. SPECIAL CONDITIONS

A. General

1. Under the schedule "local exchange" means the exchange where the station located and "foreign exchange" means the exchange from which the service is rendered.
2. Foreign exchange service will be furnished from the central office of the foreign exchange as designated by the Company or connecting utility but, at the request of the customer, may be furnished from a different central office within the same exchange or district area as provided for under Optional Prefix Service, Sheet 31 in this section.
3. The rates for local and extended service, in other than ZUM (Zone Usage Measurement) Service Areas, comprehend service without additional charge as set forth in the rates of the foreign exchange. The local service area is determined from the district area or central office area of the foreign exchange from which the service is furnished.
4. The rates applicable in connection with message toll and/or Zone Usage Measurement service over foreign exchange lines will be in accordance with the Product Guide provisions of the foreign exchange or district area.
5. The rates for primary foreign exchange service comprehend a listing in the directories having primary distribution in the local and foreign exchange.
6. Customers of foreign exchange service under this section are not required to take service of the exchange from which service normally would be furnished on the premises on which the service is furnished.
7. Except as otherwise provided in this section, service furnished in the local exchange will be available in connection with foreign exchange service at rates in accordance with the rates of the local exchange.
8. Off-premises extension station service will be furnished only for the use of the customer.
9. Extension station service will be furnished in accordance with the provisions of the local exchange.
10. Additional listings and lines of information will be furnished to foreign exchange customers in local or foreign exchange directories in accordance with the provisions in effect for the directory containing the additional listing or line of information.

---

GENERAL SERVICES

FOREIGN EXCHANGE SERVICE (Continued)

I. SPECIAL CONDITIONS (Continued)

A. General (Continued)

11. Foreign exchange service will be furnished under this section in accordance with the following conditions:

- (a) The applicant for such service may be required to pay in advance, prior to the installation of the service, an amount equal to the net cost of installing and removing any facilities necessary in connection with the furnishing of such service by the utility serving the local exchange.
- (b) If the service is retained for a period of one year or more at the same location, the Company will refund to the customer the following amounts, provided the customer retains service continuously throughout the respective periods for which payments apply and, further, provided that the customer has paid any and all sums due and payable to the Company for the service:

On the expiration of first year following installation of service, 33 1/3 percent of advance payment.

On expiration of second year following installation of service, 33 1/3 percent of advance payment.

On expiration of third year following installation of service, 33 1/3 percent of advance payment.

In addition to the above, interest will be paid on each refund payment and on the unrefunded balance at the rate of 6 percent per annum.

- (c) Nothing in this condition shall be construed as limiting or in any way affecting the right of the Company to collect from the customer any other additional sum of money which may become due and payable to the Company from the customer by reason of the service furnished or to be furnished hereunder.

Effective: April 1, 2016

---

GENERAL SERVICES

FOREIGN EXCHANGE SERVICE (Continued)

I. SPECIAL CONDITIONS (Continued)

A. General (Continued)

12. Los Angeles Exchange service from designated district areas

- (a) Los Angeles Exchange service will be furnished from the following designated district areas in the specified local exchanges, as shown under Groups I and II below.
- (b) Under this serving arrangement, the foreign exchange mileage will be computed on either a contiguous or non-contiguous basis, as shown in Exchange Service Mileage Rates, Special Conditions in this section.

(1) Group I (offered to residence and business services)

<u>Local Exchange</u>	<u>Los Angeles Exchange Designated District Areas</u>
Lakewood	District Area 6
Long Beach	District Area 6
Pico Rivera	District Area 5
Redondo	District Area 9
Santa Monica	District Area 11
Sierra Madre	District Area 3
West Los Angeles	District Area 13

(2) Group II (offered to business services only)

<u>Local Exchange</u>	<u>Los Angeles Exchange Designated District Areas</u>
Alamitos	District Area 6
Azusa/Glendora	District Area 4
Covina/Baldwin Park	District Area 4
La Habra	District Area 5
La Puente	District Area 4
Malibu	District Area 13
Monrovia	District Area 3
San Fernando	District Area 14
Sunland/Tujunga	District Area 2
Whittier	District Area 5

Effective: April 1, 2016

---

GENERAL SERVICES

FOREIGN EXCHANGE SERVICE (Continued)

I. SPECIAL CONDITIONS (Continued)

B. Business Services

1. Where there is a requirement for "Availability Control Arrangement" and the necessary service arrangement is located in the foreign exchange, the rates and charges for such service will be in accordance with the Product Guide provisions of the foreign exchange.
2. Business primary service from a contiguous foreign exchange of a connecting utility will have applicable suburban mileage measured to the rate area nearest to the point on the common boundary.
3. Business foreign exchange trunk line service may be furnished for hotel-type customers only for the purpose of receiving incoming calls.
4. Business foreign exchange individual line service furnished for Hotel-type customers in connection with a station location on a pushbutton system service on which PBX station lines also terminate will be restricted to incoming calls only.
5. The usage allowance for business is (0).
  - (a) Where the foreign exchange is a Pacific Bell's exchange within the Los Angeles or San Francisco - East Bay extended areas the Rates and Conditions for Zone Usage Measurement (ZUM) are applicable as set forth in Section 4, Local Exchange Service.
  - (b) Where the foreign exchange is this Company's exchange within the Los Angeles or San Francisco - East Bay extended area the foreign exchange rate for message and measured units of local calling is applicable.
  - (c) Where the foreign exchange is this Company's or another utility's exchange outside the Los Angeles or San Francisco East Bay extended area the foreign exchange rate for message and measured units of local calling is applicable.

Effective: April 1, 2016

---

GENERAL SERVICES

FOREIGN EXCHANGE SERVICE (Continued)

I. SPECIAL CONDITIONS (Continued)

C. Residence Services <sup>1</sup>

1. Residence foreign exchange service will be provided in connection with service from contiguous exchanges only, except for Los Angeles Exchange service from designated district areas in Lakewood, Long Beach, Pico Rivera, Redondo, Santa Monica, Sierra Madre, and West Los Angeles Exchanges.

2. Residence 30 unit allowance measured rate service is not offered on a foreign exchange basis.

3. Limitation of Service - Los Gatos Exchange.

Santa Cruz suburban foreign exchange service provided within the base rate area of the Los Gatos exchange is limited to services established on or before September 7, 1970.

4. Limitation of Suburban Foreign Exchange Service - within all exchange areas.

On or after August 7, 1984, application for Suburban Foreign Exchange line service will be accepted only from applicants whose premises are within the first two-quarters (2/4) of a mile from the boundary of the foreign and local exchanges and will only be furnished from cross-boundary facilities where operating conditions permit and individual line facilities are not available.

5. Limitation of Residence Individual line flat rate Foreign Exchange Service.

On or after August 4, 1982, all new applicants for Residence Foreign Exchange Service will be furnished Measured Rate Service from those connecting utility exchanges which offer Residence Individual line, Flat rate, foreign exchange service. This service may continue until such time as service is moved or discontinued. Beverly Hills service in West Los Angeles is excluded from this limitation. Supercedures are not permitted. Rates for Residence Foreign Exchange are in the General Exchange Tariff, Schedule No. A-1. Where Measured Rate Service is not available, Flat Rate Service will apply.

<sup>1</sup> Foreign Exchange Primary Service Residence is grandfathered and limited to existing customers at existing locations as of February 24, 2005. Moves, additions or changes will not be permitted.

GENERAL SERVICES

FOREIGN EXCHANGE SERVICE (Continued)

II. RATES AND CHARGES - Primary Service

A. Residence<sup>1</sup> - Usage charges may be applicable in addition to the residence foreign exchange primary line rate.

	<u>Monthly Rate</u>	
Rate for same grade of service in foreign exchange, plus increment as follows:	Refer to exchange schedule of Company or connecting utility.	
	<u>Nonrecurring Charge</u> <sup>2</sup>	<u>Monthly Increment</u>
1. Individual line	\$252.61	\$9.28
2. Exchange Unit, measured and message unit rates	<u>ZUM Allowance</u> (Zone 1 only)	<u>ZUM Rate</u>
(a) Where the foreign exchange is a Pacific Bell Exchange		
(1) Within the Los Angeles or San Francisco-East Bay extended areas <sup>3</sup>	60	\$.06
	<u>Measured Unit/or Message Allowance</u>	<u>Unit Rate</u>
(2) Outside the Los Angeles or San Francisco-East Bay extended areas	60	\$.06
3. The rate for message and measured units of local calling usage for residence service <sup>1</sup> applies as follows:		
(a) Measured Rate Service	<u>Initial</u> 5 Min. <sup>4</sup>	<u>Each Add'l</u> Min. <sup>4</sup>
8 a.m.to 5 p.m., <sup>5</sup> Monday thru Friday	1 unit	2/10 unit
All other days/hours including holidays	1 unit	-
(1) Message Rate Service	<u>Each Message</u>	
All days/hours	1 unit	-

<sup>1</sup> Foreign Exchange Primary Service Residence is grandfathered and limited to existing customers at existing locations as of February 24, 2005. Moves, additions or changes will not be permitted.

<sup>2</sup> Plus applicable charges as set forth in Section 3 of this Product Guide.

<sup>3</sup> For rates and conditions applicable to Zone Usage Measurement (ZUM) refer to Section 5 of this Product Guide.

<sup>4</sup> Or portion thereof

<sup>5</sup> To but not including

Effective: April 1, 2016

GENERAL SERVICES

FOREIGN EXCHANGE SERVICE (Continued)

II. RATES AND CHARGES - Business Services

A. Usage charges are applicable in addition to the business foreign exchange primary line rate.

	<u>Nonrecurring Charge</u> <sup>1</sup>	<u>Monthly Rate</u>
1. Network Access		
Each trunk or individual line <sup>2</sup>	\$252.61	\$38.70
Each individual line <sup>3</sup>	252.61	37.90
Each individual trunk <sup>3</sup>	252.61	45.40
2. Centrex Increment <sup>4</sup>		
Each Centrex line	-	12.33
3. Usage		

(a) The rate for message and measured units of local calling usage is 10 cents per unit and applies as follows:

(1) <u>Measured Rate Service</u>	<u>Initial 5 Min.</u> <sup>5</sup>	<u>Each Add'l Min.</u> <sup>5</sup>
8 a.m. to 5 p.m. <sup>6</sup>		
Monday thru Friday	1 unit	2/10 unit
All other hours and holidays	1 unit	
(2) <u>Message Rate Service</u>	<u>Each Message</u>	
All days/hours	1 unit	

<sup>1</sup> Plus applicable charges as set forth in Section 3, Service Charges.  
<sup>2</sup> Rates applicable to exchanges listed in Section 5, Sheet 2.  
<sup>3</sup> Rates applicable to exchanges listed in Section 5, Sheet 3.  
<sup>4</sup> This charge applies in addition to the Centrex line charge from Section 11.  
<sup>5</sup> Or portion thereof  
<sup>6</sup> To but not including



Effective: April 1, 2016

GENERAL SERVICES

FOREIGN EXCHANGE SERVICE (Continued)

II. RATES AND CHARGES - Business Services

A. Usage charges are applicable in addition to the business foreign exchange primary line rate. (Continued)

3. Usage (Continued)

(b) The rate for measured exchange units of local calling when this Company is the serving company within the Los Angeles or San Francisco-East Bay extended areas is 10 cents per unit and applies as follows:

<u>Measured Rate Service</u>	Initial <u>5 Min.</u> <sup>1</sup>	Each Add'l <u>5 Min.</u> <sup>1</sup>
All days/hours	1 Unit	1 Unit

(c) Measured-Rate Service. <sup>2</sup>  
When this Company is the serving company within the Los Angeles extended area or San Francisco-East Bay extended area

	First <u>Minute</u>	Each Add'l <u>Minute</u>
(1) Monday through Friday		
8:00 a.m. to 5:00 p.m. <sup>3</sup>	.0480	.0120
5:00 p.m. to 11:00 p.m. <sup>3</sup>	.0336	.0084
11:00 p.m. to 8:00 a.m. <sup>3</sup>	.0192	.0048
(2) Saturday, Sunday, Holiday		
All hours	.0192	.0048

Foreign exchange service may be furnished from any district area or exchange where facilities and operating conditions permit. In addition to the above, Los Angeles Exchange service may be furnished from designated district areas, as specified in Special Condition 11. and 12. preceding, at the above monthly rates. The applicable mileage charges in this section, plus a flat rate of \$4.80, will apply in lieu of other foreign exchange mileage. (See Special Conditions for Exchange Services Mileage Rates in this section.)

<sup>1</sup> Or portion thereof

<sup>2</sup> Service available upon implementation of per-minute calling rates in the exchange in which the office providing dial tone is located.

<sup>3</sup> To, but not including

Effective: April 1, 2016

---

GENERAL SERVICES

EXCHANGE SERVICES MILEAGE RATES

III. SPECIAL CONDITIONS

A. Optional Prefix Services

1. The rate below will apply in addition to the primary service rate for the class, type and grade of service furnished, for the following service arrangements:
  - a. Dial service assistance for the physically handicapped.
  - b. Retention or assignment of a telephone number to a primary service located in a central office area other than the serving central office area.
2. The primary rate and calling area of the serving central office applies to each of the above serving arrangements.
3. The rate below applies to airline distance between the two central offices.

B. Foreign Exchange Service

1. Rates for contiguous service as shown in Rates following are applicable to the airline distance measured between the customer's service location or private branch exchange attendant position and the nearest point on the common boundary of the foreign and local exchange.
2. Rates for noncontiguous service as shown in Rates following are applicable to the computed airline distance between the rate centers of the local exchange or district area and the foreign exchange or district area.

Effective: April 1, 2016

---

GENERAL SERVICES

EXCHANGE SERVICES MILEAGE RATES (Continued)

III. SPECIAL CONDITIONS (Continued)

B. Foreign Exchange Service (Continued)

3. Foreign exchange mileage charges for Los Angeles Exchange Service from designated district areas in the exchanges or district areas shown below will be computed (1) on a contiguous basis from a point on the common boundary, and (2) on a noncontiguous basis between rate centers, as follows:

a. Contiguous serving arrangement

Los Angeles Exchange Service in the exchange or district area designated as	<u>Common boundary of the exchanges designated as</u>
Downey Los Angeles Exchange <sup>1</sup>	Downey - D.A. No. 6 of
Lakewood between Obispo Avenue and west side of Downey Avenue.	Lakewood - Compton
Long Beach between Long Beach Boulevard and west side of Obispo Avenue.	Long Beach - Compton
Pico Rivera	Pico Rivera - Montebello
Redondo	Redondo - Hawthorne
Santa Monica	Santa Monica - Culver City
Sierra Madre	Sierra Madre - Pasadena
West Los Angeles	West Los Angeles - Beverly Hills

<sup>1</sup> The flat rate charge as shown in Foreign Exchange Service Rates – Business Service, Rates II.A.3.(c) in this Section does not apply.

Effective: April 1, 2016

---

GENERAL SERVICES

EXCHANGE SERVICES MILEAGE RATES (Continued)

III. SPECIAL CONDITIONS (Continued)

B. Foreign Exchange Service (Continued)

3. (Continued)

b. Noncontiguous serving arrangement

Los Angeles Exchange Service  
in the exchange of district area  
designated as

Common boundary of the  
exchanges designated as

Alamitos

Alamitos and Compton Exchanges

Azusa-Glendora

Covina and Alhambra Exchanges

Covina-Baldwin Park

Covina and Alhambra Exchanges

La Habra  
Exchanges

La Habra and Montebello

La Puente

Covina and Alhambra Exchanges

Norwalk  
of Los Angeles Exchange

Norwalk Exchange and D.A. No. 6 <sup>1</sup>

Malibu  
Exchanges

Malibu and Beverly Hills

Monrovia  
Pasadena D.A. of Pasadena  
Exchange

Monrovia Exchange and

San Fernando  
Hollywood Exchanges

San Fernando and North

Sunland - Tujunga  
Glendale Exchanges

Sunland - Tujunga and

Whittier

Whittier and  
Montebello Exchanges

<sup>1</sup> The flat rate charge as shown in Foreign Exchange Service Rates – Business Service, Rates II.A.3.(c) in this Section does not apply.

Effective: April 1, 2016

---

GENERAL SERVICES

EXCHANGE SERVICES MILEAGE RATES (Continued)

IV. RATES AND CHARGES

A. OPTIONAL PREFIX SERVICE <sup>1</sup> - within an exchange or district area at the request of the customer, served from a central office which is not the serving central office, designated by the Company.	Monthly Rate Each <u>Mile or Fraction</u>
1. Airline measurement between the central office designated by the Company and the requested central office, each line or trunk	\$7.00
B. FOREIGN EXCHANGE SERVICE <sup>2</sup>	
1. Contiguous Exchanges (For special arrangement in the Los Angeles Exchange refer to Special Condition B.3.)	
a. Within the Local Exchanges	Monthly Rate Each 1/4 Mile <u>or Fraction</u>
Airline measurement from the service location of the primary line, Airport Intercommunicating or EBSS/Centrex station lines to the nearest point on the common boundary.	
Each line or trunk	\$3.50

<sup>1</sup> Effective November 16, 2013, Optional Prefix Service is no longer available for purchase by residence customers. Existing residence customers of record may retain this service at existing locations in accordance with the terms and conditions described herein. Service is not offered for new installations, moves, changes, or additions.

<sup>2</sup> Residence Foreign Exchange Service grandfathered January 14, 2005, not available to new customers.

Effective: April 1, 2016

---

GENERAL SERVICES

EXCHANGE SERVICES MILEAGE RATES (Continued)

IV. RATES AND CHARGES

B. FOREIGN EXCHANGE SERVICE <sup>1</sup> (Continued)

1. Contiguous Exchanges (Continued)

	<u>Monthly Rate Each 1/4 Mile or Fraction</u>
b. Within the foreign exchange	
(1) Primary service served from a connecting utility. Suburban mileage, airline measurement from the point on the common boundary to the nearest point on the boundary of the rate area from which the service is rated.	2
(2) Centrex station line service	
(a) Within the Company's exchange. Airline measurement from the central office serving the primary location to the nearest central office serving the common boundary.	\$3.50
If the primary location is served from a central Office serving the common boundary, no charge applies.	
(b) Within an exchange of Pacific Bell. Airlines measurement from the point on the common boundary, as determined in 1.a., preceding, to the customer's primary location.	3.50
(3) Airport Intercommunicating station line service from a system in an exchange of Pacific Bell. Airline measurement from the point on the common boundary, as determined in 1.a., preceding, to the customer's primary location.	3.50

<sup>1</sup> Residence Foreign Exchange Service grandfathered January 14, 2005, not available to new customers.

<sup>2</sup> See connecting Utility's Tariff and/or Product Guide.

Effective: April 1, 2016

---

GENERAL SERVICES

EXCHANGE SERVICES MILEAGE RATES (Continued)

IV. RATES AND CHARGES

B. FOREIGN EXCHANGE SERVICE <sup>1</sup> (Continued)

1. Contiguous Exchanges (Continued)

	<u>Monthly Rate Each 1/4 Mile or Fraction</u>
c. The total mileage charge is the sum of charges determined under 1.a., and 1.b. preceding.	
d. Optional Prefix Service	
(1) Within the foreign exchange. Airline measurement between the central office designated by the Company or connecting utility and the requested central office.	
(a) Where the foreign exchange is a pacific Bell exchange or district area, each line or trunk.	2
(b) Where the foreign exchange is this Company's exchange or district area, each line or trunk.	\$7.00
e. Business Extension Line or PBX Station Line.	
(1) When the primary station line or PBX attendant position is connected for foreign exchange service from the exchange of the off-premises location. Airline measurement between the primary location or PBX attendant position and the off-premises location. Terminations on Non-continuous Property	3.50
(2) When the primary station line or PBX attendant position is not connected for foreign exchange service from the exchange in which the off-premises station is located.	
(a) Airline distance measured between the off-premises station location and the nearest point on the common boundary of the local and foreign exchange.	3.50
(b) Airline distance measured between point on the common Exchange boundary, as established above, to the primary location or PBX attendant position.	

<sup>1</sup> Residence Foreign Exchange Service grandfathered January 14, 2005, not available to new customers.

<sup>2</sup> Rate applicable in connecting Utility's Tariff and/or Product Guide.

Effective: April 1, 2016

GENERAL SERVICES

EXCHANGE SERVICES MILEAGE RATES (Continued)

IV. RATES AND CHARGES

B. FOREIGN EXCHANGE SERVICE <sup>1</sup> (Continued)

1. Contiguous Exchanges (Continued)

	<u>Monthly Rate Each 1/4 Mile or Fraction</u>
f. Within exchanges of the Company and when the service location of an extension station line, auxiliary station line or private branch exchange station line is located in an exchange contiguous to that of the primary station location, or attendant position.	
(1) Each extension line auxiliary station line, or private branch exchange station line.	
(a) Airline measurement, from the station location to the nearest point on the common exchange boundary.	\$3.50
(b) Airline measurement, from said nearest point on the common exchange boundary to the primary station location or attendant position.	3.50

Monthly Rate

2. Noncontiguous Exchanges  
 (For special arrangement in the Los Angeles Exchange refer to Special Condition B.3.)

Airline measurement between rate center of foreign or serving exchange or district area and local exchange or district area, each mile or fraction (See General Exchange Tariff, Schedule Rule No. 14)	\$7.00
--	--------

Monthly Rate  
Each 1/4 Mile  
or Fraction

3. Concentrator - Identifier

a. Identifier in an exchange of the Company, Concentrator in Connecting Utility.	
Airline measurement between the Concentrator Unit and the Identifier Unit, per circuit.	\$1.15

<sup>1</sup> Residence Foreign Exchange Service grandfathered January 14, 2005, not available to new customers.



---

GENERAL SERVICES

HIGH VOLTAGE PROTECTION SERVICE<sup>1</sup>

I. GENERAL

Applicability

Applicable to High Voltage Protection Services used to isolate or neutralize ground potential rise or induced voltage caused by faults in electric power systems.

II. SPECIAL CONDITIONS

A. Definitions

Ground Potential Rise (GPR). A voltage difference between two or more ground electrodes caused by earth return currents. GPR on cable pairs can occur, for example, when current from lightning surges flow to ground, but GPR often is associated with voltage generated as the power system fault currents flow to ground. Maximum GPR is developed by the percentage of line-to-ground fault current entering earth through an electrode impedance.

Induction. The resultant electromotive force in a circuit or component caused by changes in the magnetic flux linking with the circuit or component (electromagnetic induction (EMI)) or caused by the longitudinal voltage impressed, under fault conditions, on a telecommunications facility due to the mutual coupling between telecommunications lines and power lines (longitudinal induction).

Interruptible. Self-restoring services which must function before and after power-fault conditions. (Class B.)

Look-back Device. A device that allows transmission testing of special access lines from a testing center or central office.

Non-Interruptible. Services which must function before, during, and after power-fault conditions. (Class A.)

B. Description

The Company requires a high voltage protector (HVP) to be installed at any location to which an exchange service is provided and an HVP and a loop-back testing device to be installed at any location to which a private line or special access service is provided if the customer location is an electrical power station or is any other location where hazardous conditions exist due to ground potential rise (GPR), and/or induced voltage caused by faults in the electrical power system.

This service will provide high voltage isolation for telecommunications, while enabling the normal ac and dc signaling between C.O. and substation equipment during GPR environment due to electrical power faults.

<sup>1</sup> Effective September 5, 2012, High Voltage Protection Service – Class A is grandfathered and no longer available to new customers. Frontier will continue to provide service to existing customers at their current locations. Moves, adds or changes to the existing service are not permitted.

---

GENERAL SERVICES

HIGH VOLTAGE PROTECTION SERVICE <sup>1</sup> (Continued)

II. SPECIAL CONDITIONS (Continued)

C. Conditions

1. Based on data provided by the customer, the Company shall determine the proper levels of protection required on its network to isolate or neutralize electrical hazard.
2. As a condition to receiving service, potential customers shall provide the Company, in writing, the technical data necessary for determining the high voltage protection requirements, at the time of application of the initial service, additions to, or changes in the existing service. In addition, the customer shall notify the Company prior to making changes in the electrical supply which will increase the GPR at the location.
3. The high voltage protection equipment will be located at the Network Interface (NI) or demarcation point for specially protected telephone facilities at power stations. The Company will be responsible, up to this point, for the provisioning of channels and/or services regardless of ownership of the special high voltage protection equipment.
4. High voltage protection equipment may also be required on the serving telephone facilities at the Company's Central Office and at Remote Drainage Locations.
5. The rates, charges, termination liabilities, and conditions of this section apply to High Voltage Protection Services placed at the point of demarcation on a customer's premises location along the length of the Excess Footage portion of a line extension or service connection where the Company determines a High Voltage Protection Service is necessary to prevent damage or harm from faults in high voltage systems located at a customer's premises.
6. If equipment for high voltage protection is disconnected at the request of the customer or because the customer's telephone service is disconnected in accordance with Company's terms and conditions, the customer shall pay the remaining basic termination charges. Basic termination charges for fractional portions of a month shall be prorated.
7. The Company shall be indemnified and held harmless for any and all loss, claims, demands, suits or other action or liability whatsoever, whether suffered, made, instituted or asserted by the customer or by any other party or person, for any injury to or death of a person or persons, or for any loss, damage or destruction of any property, whether owned by the customer or others, caused or claimed to have been caused directly or indirectly by the installation, operation, failure to operate, maintenance, removal, presence, condition, location, or use of equipment and services associated with high voltage protection equipment furnished by the Company or with customer equipment when combined or connected with facilities of the Company. Services provided by the Company shall not cause the Company to become responsible for damage, loss, or claims caused by electrical hazards resulting from a customer's electric power system.

<sup>1</sup> Effective September 5, 2012, High Voltage Protection Service – Class A is grandfathered and no longer available to new customers. Frontier will continue to provide service to existing customers at their current locations. Moves, adds or changes to the existing service are not permitted.

Effective: April 1, 2016

---

GENERAL SERVICES

HIGH VOLTAGE PROTECTION SERVICE <sup>1</sup> (Continued)

II. SPECIAL CONDITIONS (Continued)

C. Conditions

8. Interruptions or outages of exchange or private line services provided to customers at electric power stations may occur for reasons, such as facility damage due to storm loading, vehicle accident, lightning strike, or other acts of God. Circuit failures caused by such events cannot be prevented by services provided in accordance with this section (however, interruptions and service outages due to fault-produced ground potential rise and induction can be minimized). The Company expressly states that provision of the equipment provided in this section cannot prevent such service outages as may normally occur due to the proceeding circumstances. It is the responsibility of the customer to provide sufficient protection to prevent damage caused by such events.
9. Ground start circuits will be provided by the Company in accordance with the terms and conditions of this Product Guide.
10. Non-Interruptible services may require alternative routing. Alternative routing will be provided on an individual case basis.

D. Rates and Charges

The rates and charges specified in this section apply to high voltage protection equipment furnished by the Company but do not apply to equipment, cabinets, or mounting arrangements provided by the customer or the Company. Additional charges may be applicable for Company-provided equipment, cabinets, and mounting arrangements.

E. Service Types

Type 1 - Services requiring either dc transmission or ac and dc transmission, such as, Basic Exchange Access Line Services and Private Line Services. Available as Class A (non-interruptible) or Class B (interruptible).

Type 2 - Private Line Service's requiring dc transmission or ac dc transmission for pilot wire protective relaying or dc tripping. Available as Class A (non-interruptible) or Class B (interruptible).

Type 3 - Service for Private Line Services requiring ac transmission for supervisory control and data. Available as Class A (non-interruptible) or Class B (interruptible).

Type 4 - Service for Private Line Services requiring ac transmission for audio tone protective relaying. Available as Class A (non-interruptible) or Class B (interruptible).

<sup>1</sup> Effective September 5, 2012, High Voltage Protection Service – Class A is grandfathered and no longer available to new customers. Frontier will continue to provide service to existing customers at their current locations. Moves, adds or changes to the existing service are not permitted.

---

GENERAL SERVICES

HIGH VOLTAGE PROTECTION SERVICE <sup>1</sup> (Continued)

II. SPECIAL CONDITIONS (Continued)

F. Service Performance Objective Classifications

Because of the customer's need for service continuity during power system faults on some types of telecommunication services provided to power stations, the following system of service performance objective classifications has been established for the purpose of permitting the customer to specify the performance objectives for most types of telecommunication services provided to power stations.

1. Class A - Non-interruptible service performance (must function before, during, and after the power fault).
2. Class B - Self-restoring interruptible service performance (must function before and after the power fault condition).

G. Provision of High Voltage Protection Equipment

Based on the customer's technical data provided to the Company, the Company will provide the necessary high voltage protection equipment at the Company's local loop demarcation point on the customer's premises, at the Company Central Office, and at the remote drainage location. The placement of the equipment by the Company shall in no way release the customer of its responsibility for damage, loss or claims caused by electrical hazards resulting from the customer's electric power system.

The customer may elect to furnish the equipment at its premises to isolate or neutralize the electrical hazard subject to the approval of the Company; however, such approval by the Company shall not relieve customer of its responsibility to install or maintain adequate high voltage protection equipment.

When the customer provides the high voltage equipment at its premise, the Company will provide the necessary high voltage equipment at the central office and remote drainage location.

The high voltage protection equipment at the power station will either be exclusively owned by the Company or the customer.

The Company will inspect and verify adequacy of the high voltage protection equipment when service is established and at such future times as deemed necessary due to additions, deletions, rearrangements, routine maintenance or for the purpose of verifying the adequacy of the high voltage protection equipment.

<sup>1</sup> Effective September 5, 2012, High Voltage Protection Service – Class A is grandfathered and no longer available to new customers. Frontier will continue to provide service to existing customers at their current locations. Moves, adds or changes to the existing service are not permitted.

Effective: April 1, 2016

GENERAL SERVICES

HIGH VOLTAGE PROTECTION SERVICE <sup>2</sup> (Continued)

III. RATES AND CHARGES

	Basic Termination <u>Liability</u> <sup>1</sup>	Non- Recurring <u>Charge</u>	Monthly <u>Rate</u>
A. Type 1			
Class A, each	\$2,382.00	\$386.22	\$80.25
Class B, each	1,605.00	386.22	57.34
B. Type 2			
Class A, each	2,659.00	386.22	88.40
Class B, each	1,881.00	386.22	65.49
C. Type 3			
Class A, each	1,757.00	386.22	61.83
Class B, each	967.00	386.22	38.55
D. Type 4			
Class A, each	1,791.00	386.22	62.84
Class B, each	1,014.00	386.22	39.94
E. Installation of customer- provided devices	NA	386.22	NA
F. Loop-Back Device	NA	NC	NC

<sup>1</sup> Basic Termination Liability is reduced 1/288 with each monthly payment.

<sup>2</sup> Effective September 5, 2012, High Voltage Protection Service – Class A is grandfathered and no longer available to new customers. Frontier will continue to provide service to existing customers at their current locations. Moves, adds or changes to the existing service are not permitted.

Effective: April 1, 2016

---

GENERAL SERVICES

MISCELLANEOUS BILLING SERVICE

I. MULTIPLE BILL COPY SERVICE (MBCS)

A. Special Conditions

1. The Company is required to provide customers a single copy of their bill at no charge.
2. No more than three additional copies will be provided at the monthly recurring rate.
3. This service is available on a one-time basis or on a recurring monthly basis.
4. All applicable rates and service order charges will apply to each one-time order as well as to any other order.
5. No charge applies to replace bill copies not received, lost or stolen.
6. No penalty applies to a cancellation of a recurring monthly basis service.
7. All rates and charges will apply when MBCS is reinstated.
8. The rate and charge for MBCS is applicable to business service only.

B. Rates and Charges

	<u>Nonrecurring Charge</u>	<u>Monthly Rate</u>
Original with one to three copies per business account only	1	\$ 2.00

<sup>1</sup> Subsequent service order charge from Section 3 will apply unless service is ordered at the time initial service is established.

Effective: April 1, 2016

---

GENERAL SERVICES

MISCELLANEOUS BILLING SERVICE (Continued)

II. CALL SCREENING <sup>1</sup>

A. Special Conditions

1. Call Screening service will prevent the billing of collect or third number billed calls to the telephone number of the call screening service customer. Call screening service will not prevent outgoing collect or third number billed calls made from the telephone service of the call.
2. Collect or third number billed calls accepted by the customer with call screening will be billed to the customer. These calls may not be disputed or adjusted.
3. Collect billed call screening is not allowed on Official accounts.
4. Call screening is provided where facilities and operating conditions permit.
5. This service is available only to customers in the exchanges listed in Section 4A, Sheet 4 of this Product Guide.

B. Rates and Charges

	<u>Monthly Rate</u>
1. Restricts incoming toll calls to prohibit third number billed calls	\$1.50
2. Restricts incoming toll calls to prohibit collect billed calls	1.50
3. Restricts incoming toll calls to prohibit collect and third number billed calls	2.00

<sup>1</sup> This service is available only to customers in the exchanges listed in Section 5, Sheet 3 of this Product Guide.

Effective: April 1, 2016

---

GENERAL SERVICES

MISCELLANEOUS BILLING SERVICE (Continued)

III. SPECIAL BILLING NUMBER SERVICE

A. Special Conditions

1. The service provides for furnishing to a customer, each month, in connection with the regular exchange service bill, a separate listing of toll telephone messages for each special billing number used in placing calls.
2. The minimum period for which the service is offered is two months.
3. Zone calling unit rates are not applicable in connection with special billing number service.

B. Rates and Charges

	<u>Monthly Rate</u>
1. First group of 50, or less, Special Billing Numbers	\$21.05
2. Each additional group of 50, or less, Special Billing Numbers	10.55



Effective: April 1, 2016

---

GENERAL SERVICES

MISCELLANEOUS BILLING SERVICE (Continued)

IV. LEVEL BILL PLAN (LBP)

A. Special Conditions

1. The LBP is available to large telephone users excluding IECs, whose accounts average \$10,000 per month. The account must be in service for a full 12 months prior to participation in the LBP.
2. Subscription to the plan will be open on a quarterly basis. Enrollment requests must be received by the Company a minimum of 30 days prior to the next quarter. This lead time enables determination of the appropriate LBP amount and the necessary billing system preparation. The LBP amount will be based on the last 12 months of billing divided by 12 to determine the account's monthly average. The LBP amount will be reviewed and adjusted annually.
3. All monthly service rates and charges will be billed at regular billing cycles. The bill format will be revised to reflect the LBP amount due and payable, and the credit or debit status relative to the amounts paid versus amounts billed.
4. The centralized credit check system (CCCS) may be utilized to determine credit worthiness of new applicants to the LBP. An account whose service is temporarily disconnected for non-payment within the preceding 12 month period may be denied the LBP.
5. A settlement procedure will occur in the month following each quarter whereby the difference between the amount paid the previous quarter and the actual amount billed will be debited or credited to the next month's level payment.
6. The plan will be processed in quarterly cyclic periods, as follows.  
  
(Re) Establishment in January, True Up in April  
(Re) Establishment in April, True Up in July  
(Re) Establishment in July, True Up in October  
(Re) Establishment in October, True Up in January
7. Discontinuance requests must be made no later than 30 days prior to the next monthly billing cycle. These accounts will be eligible to request participation in the LBP at a later date.
8. LBP accounts will be exempt from the Late Payment Charge (LPC). If the LBP is not received within 22 days from the date on the bill, the LBP will be cancelled by the Company and procedures as set forth in the General Exchange Tariff, Schedule D&R Rules No. 9 and 10 will be applicable. The LPC will then be applicable to the first bill following discontinuance of participation in the LBP. A penalty will be incurred whereby the account will not be eligible for participation in the LBP option for 12 months following the account's cancellation from the plan by the Company.

B. Rates and Charges

	<u>Nonrecurring Charge</u>	<u>Monthly Rate</u>
Each Account	\$33.00	\$24.75

Effective: April 1, 2016

---

GENERAL SERVICES

TELEPHONE ANSWERING SERVICE

I. APPLICABILITY

Applicable to the termination of answering and secretarial line services individual line primary service on services furnished to a customer for the purpose of providing telephone answering service to his clients (See Special Conditions).

II. TERRITORY

Within the exchange areas of all exchanges, as said areas are defined on maps as part of this Product Guide.

III. SPECIAL CONDITIONS

A. Application of Service

1. A customer is considered engaged in the telephone answering service business when 10 or more off-premises extension station line services of one or more different clients of the customer are terminated on a premises of said customer and will be required to subscribe to telephone answering service as set forth in this Product Guide.
2. Telephone answering service is furnished to enable customers to answer incoming calls on lines of customer's clients and for the conduct of the customers business. The telephone answering service will be provided two-way individual line primary service for its use.

The clients of a telephone answering service will be provided only one-way incoming service over the Company's lines to telephone answering service arrangements by means of primary service (answering) lines or extension service (secretarial lines). Clients of a telephone answering service may also terminate the following:

- (a) A local private line channel provided the other termination is in customer-provided station equipment on a different premises.
  - (b) Interexchange private line channels, which contemplate a two-point connection with one end being the telephone answering service. Connection of such channels to the exchange network through primary lines of the customer or extension to another private line is not contemplated, nor may the arrangement be used for switching of calls, a service normally provided by the Company. Such switching for the purpose of circumventing service charges of the Company, is in violation of the terms and conditions of the Company.
3. Service under this schedule does not contemplate communication service through the connection of two lines which terminate on the connecting block except as set forth in Special Conditions.

B. Answering line service is service employing a central office line terminating a connecting block and is designed to enable the customer to answer incoming calls of a client.

C. Secretarial line service is provided for clients only and is furnished by means of an extension of a client's service terminating on a connecting block. It is furnished only in connection with individual line primary service as set forth under Special Condition 12 or PBX station line service or multiples of PBX trunks or dial mobile unit when transfer circuit is provided.

Effective: April 1, 2016

---

GENERAL SERVICES

TELEPHONE ANSWERING SERVICE (Continued)

III. SPECIAL CONDITIONS (Continued)

- D. Individual primary line service employing a central office line equipped for 2-way service is furnished only in the name of the telephone answering service. The line will terminate on a connecting block.
- E. An application for connection of a client's line to a telephone answering serving arrangement shall be accepted from the client or from his telephone answering service. The Company will verify with the client when service is to be discontinued at one telephone answering service and connected at another answering service.
- F. Charges for answering lines, secretarial lines and mileage will be billed to the clients. The other charges will be billed to the customer.
- G. If for any reason service to the customer is discontinued, all service associated with the telephone answering service arrangement will also be discontinued. If for any reason the exchange service to the client is discontinued, the line to the answering arrangement will be discontinued.
- H. Telephone answering serving arrangements may be furnished by the Company at its option subject to the terms and conditions as set forth under 1. or 2. below:
  - 1. At initial payment, payable upon request prior to the installation of the serving arrangement(s), equal to the cost of the arrangement(s) and cable facilities necessary in connection with the furnishing of the service to clients of the telephone answering service customer and installation less the cost of the recoverable serving arrangement(s) and facilities plus the estimated cost of removal, shall be made to the Company by the customer. For each full month the customer retains such service the Company will refund to the customer an amount of money equal to 1/60th of the amount of the initial payment, except that the refunds will be accumulated for a twelve month period, at which time payment will be made to the customer. These annual refunds will include interest on the refunded amount and on the refunded balance at the rate of seven percent per annum. In the event the customer does not retain service for a full twelve month period the Company will refund to the customer, the accumulated credit for each full month the customer retained service in that portion of the twelve month period service was discontinued with seven percent interest per annum.
  - 2. The Company may enter into a contract with a customer requiring that if the service is not retained by the customer in conjunction with exchange service for a minimum of five years from the date of installation, the customer will pay to the Company an amount of money equal to the net cost of installing and removing any serving arrangement and cable facilities necessary in connection with the furnishing of the service to clients of the telephone answering service customer less the amount paid as installation charges; this amount to decrease by 1/60th for each month the customer retains service.
  - 3. The Company has the option of applying either of the terms and conditions under 1. or 2. Above. Nothing in this condition shall be construed as limiting or in any way affecting the right of the Company to collect from the customer any other or additional sum of money which may become due and payable to the Company from the customer by reason of the service furnished or to be furnished hereunder.
  - 4. Basic Termination Charges will apply in addition to initial or subsequent payment agreements relative to the retention by the customer of services for not less than five full years.

Effective: April 1, 2016

---

GENERAL SERVICES

TELEPHONE ANSWERING SERVICE (Continued)

III. SPECIAL CONDITIONS (Continued)

- I. Applicable to Concentrator-Identifier System Serving Arrangements
  1. Concentrator-identifier systems will be furnished only in connection with cord type answering service.
  2. Each concentrator-identifier system will consist of one concentrator unit and one identifier unit with a minimum of two and a maximum of six circuits between the units.
  3. Concentrator-identifier serving arrangement(s) will be offered intra-exchange (see Special Condition I.9. below) and inter-exchange provided that facilities and operating conditions permit and that the concentrator unit and the identifier unit be located in the same or contiguous exchange, or district area of this Company as the associated cord type answering attendant position.
  4. Charges for the concentrator-identifier system and for the mileage between the concentrator unit and the identifier unit will be billed to the customer. Charges for secretarial lines, multiples of a PBX trunk, or answering lines terminating on concentrator-identifier arrangement(s) will be billed to the clients.
  5. The furnishing of a concentrator-identifier system contemplates a minimum of forty secretarial lines or multiples of a PBX trunk terminating on the service. If there are less than forty such lines, the customer will be billed the difference between the actual number of lines terminating on the service and forty lines, at the rate per month of \$11.84 per station.
  6. In multiposition installations not equipped with an all trunks busy unit, the 100-line jacks associated with one concentrator-identifier system shall not be divided between more than two adjacent positions.
  7. Only concentrator-identifier terminations will appear in jack-strips associated with concentrator-identifier system.
  8. Answering line service terminated on concentrator-identifier arrangement is furnished only to parties other than the customer to the telephone answering service.
  9. Service between central offices within an exchange will be limited to those ordered or installed prior to August 22, 1978.

Effective: April 1, 2016

---

GENERAL SERVICES

TELEPHONE ANSWERING SERVICE (Continued)

III. SPECIAL CONDITIONS (Continued)

- J. Jointly Provided Concentrator-Identifier System (Identifier in an exchange of the Company)
1. Applicable to a serving arrangement where the identifier unit is located in an exchange of the Company.
  2. Service will only be provided between contiguous exchanges where facilities and operating conditions permit. The utility providing the identifier will determine the facilities and operating conditions.
  3. For new systems, there will be minimum of two and a maximum of six circuits between the concentrator and identifier units. Where an existing service cannot be modified, the maximum will remain at four circuits.
  4. Charges, rates and conditions applicable to the identifier unit and the concentrator-identifier trunks will be those of the utility who provides the identifier. Charges, rates and conditions applicable to the concentrator unit include services terminated on that concentrator unit, except concentrator-identifier trunks, will be those of the utility who provides the concentrator unit.
  5. Charge and rates for the concentrator, identifier and concentrator-identifier drunks are to be billed to the customer.
  6. Identifier units will be furnished only in connection with cord-type attendant positions.
  7. To meet operating conditions, additional outside plant facilities for talking and/or signaling and supervision on a concentrator-identifier system may be required, and the rate for each additional such facility required will be the same as the mileage rate set forth in Section 6 of this Product Guide for each concentrator-identifier trunk.
  8. In multi-positions installations not equipped with an all trunks busy unit, the 100-line jacks associated with one concentrator-identifier system shall not be divided between more than two adjacent positions.
  9. Only concentrator-identifier terminations will appear in jack-strips associated with concentrator-identifier system.
  10. Answering line service terminated on concentrator-identifier arrangement is furnished only to parties other than the customer to the telephone answering service.

Effective: April 1, 2016

---

GENERAL SERVICES

TELEPHONE ANSWERING SERVICE (Continued)

III. SPECIAL CONDITIONS (Continued)

- K. Jointly Provided Concentrator-Identifier Systems  
(Concentrator in an exchange of the Company)
1. Applicable to a serving arrangement where the concentrator unit is located in an exchange of the Company.
  2. Service will only be provided between contiguous and noncontiguous exchanges where facilities and operating conditions permit. The utility providing the identifier will determine the facilities and operating conditions.
  3. Charges, rates and conditions applicable to the identifier unit and the concentrator-identifier trunks will be those of the utility who provides the identifier. Charges, rates and conditions applicable to the concentrator unit including services terminated on that concentrator unit, except concentrator-identifier trunks, will be those of the utility who provides the concentrator unit.
  4. Charges and rates for the concentrator, identifier and concentrator-identifier trunks are to be billed to the customer.
  5. To meet operating conditions, additional outside plant facilities for talking and/or signaling and supervision on a concentrator-identifier system may be required, and the rate for each additional such facility required will be the same as the mileage (transport) rate set forth in the Facilities for Intrastate Access Tariff C-1, for each concentrator-identifier trunk.
- L. When a building complex consisting of one or more structures is owned, leased or managed by a single entity and all portions may be served without crossing a public thoroughfare or property of another, the facility between the serving central office and the attendant position is a special access line as shown in the Facilities for Intrastate Access Tariff C-1. Conduit required between structures will be provided at the expense of the customer.
- M. Where structures of a complex are separated by a public thoroughfare, the above mileage charges will be applicable and the customer pays for any unusual costs which may be involved in the furnishing of facilities across the public thoroughfare, or the customer furnishes at his expense, an underground (or enclosed overhead) pedestrian passageway suitable for the running of telephone circuits between the structure of the complex separated by the thoroughfare.
- N. When the Company revises a central office serving area boundary, or an exchange boundary, which may increase billing for mileage to clients of an answering bureau or to the customer, the Company will apply the existing mileage billing on a deviation basis for a period not to exceed five years from the date of such revision, unless the service is terminated, changed or suspended within such time period.

Effective: April 1, 2016

---

GENERAL SERVICES

TELEPHONE ANSWERING SERVICE (Continued)

III. SPECIAL CONDITIONS (Continued)

O. Candela

Electronic concentrator located in the Company central office. Client lines are terminated on the concentrator unit. Identification of client lines is provided by the customer at the customer premises.

1. Master Concentrator - A master concentrator provides capacity for up to 256 client lines. A maximum of 2 slave concentrators may be connected to the master concentrator to provide up to 768 client lines and 16 trunk capability.
2. Slave Concentrator - The slave concentrator provides capability for an additional 256 client lines to be connected to the master concentrator.
3. Line Card - The line card provides for connection of up to 32 client lines to the concentrator. Eight line cards may be connected for a single 256 line concentrator assembly. The line card is used for both the master and slave concentrators.
4. Data Modem - The optional data modem allows the customer to change the ring count on a client's line. One data modem is required in the Company central office and one must be provided by the customer at the customer premises.
5. Applications and Conditions
  - (a) Each concentrator is restricted for use by one customer.
  - (b) Electronic concentrators are not compatible with existing concentrators.
  - (c) Only a Company provided concentrator will be installed in a Company central office.
  - (d) Concentrators may be located in the same serving central office area as the telephone answering bureau, within a district area of the same exchange and in contiguous and noncontiguous exchanges where facilities and operating conditions permit.
  - (e) Electronic concentrator equipment will be furnished between exchanges of the Company and other local exchange carriers where facilities, operating conditions and Tariffs and/or Product Guide's permit. Rates, charges, terms and conditions applicable to the electronic concentrator and the services terminated on the concentrator will be those of the utility providing the concentrator equipment.
  - (f) Concentrator equipment will be furnished only so long as it provides answering service arrangements to the exchange or area designated by the customer to be serviced by the concentrator.
  - (g) Electronic concentrator systems will be furnished only in connection with customer's electronic answering service. Customer premises equipment compatible with the electronic concentrator is solely the responsibility of the customer.
  - (h) Each concentrator system will consist of one concentrator unit with a minimum of 2 and a maximum of 16 circuits between the concentrator and the customer premises. A concentrator system contemplates a minimum of 32 client lines terminating on the unit. If there are less than 32 client lines, the customer will be billed the difference between the actual number of client lines terminating on the unit and 32 lines, at the rate of \$4.15 per month per station.

Effective: April 1, 2016

---

GENERAL SERVICES

TELEPHONE ANSWERING SERVICE (Continued)

III. SPECIAL CONDITIONS (Continued)

O. Candela (Continued)

5. Applications and Conditions (Continued)

- (i) Charges for the concentrator system and for circuit mileage between the concentrator unit and the customer premises will be billed to the customer. The circuit mileage (transport) rate is set forth in the Facilities for Intrastate Access Tariff C-1. Charges for answering or secretarial (client) lines terminating on the concentrator unit will be billed to the client.
- (j) Concentrator trunk circuits will terminate on a standard network device at the customer premises and be so labeled by the Company.
- (k) The telephone answering service will specify the circuitry the client line is to occupy on the concentrator.

6. Jointly Provided Concentrator System

- (a) Applicable to an arrangement where the customer premises (telephone answering service) is located in the territory of a different utility.
- (b) Service will only be provided between contiguous exchanges where facilities and operating conditions permit.
- (c) There will be a minimum of 2 and a maximum of 16 trunk circuits between the concentrator and customer premises identification equipment.
- (d) The charges and rates for the concentrator and concentrator circuits (trunks) will be billed to the customer.
- (e) Customer premises equipment compatible with the electronic concentrator is solely the responsibility of the customer.

7. Optional Equipment - Data Modem

- (a) The Candela™ concentrator uses a fixed ring count as a standard feature. The customer has the option of subscribing to a customized ring count and the ability to change the ring count.

The option consists of: a central office data modem, a customer provided data modem, and a special access line (SAL). Conditioning from the Facilities for Intrastate Access Tariff C-1 may be required.

- (b) The customer must provide a data modem on the customer premises that is compatible with a Rixon model No. 4624/VS.
- (c) The customer must order a special access line from the Facilities for Intrastate Access Tariff C-1. The SAL will connect the customer's premises to the central office in which the concentrator is located.



Effective: April 1, 2016

GENERAL SERVICES

TELEPHONE ANSWERING SERVICE (Continued)

IV. RATES AND CHARGES

	<u>BTC</u>	<u>Nonrecurring Charge</u>	<u>Monthly Rate</u>
A. Concentrator-identifier <sup>1</sup> system arrangement(s) provided entirely within exchange(s) of the Company			
1. Concentrator-identifier system <sup>2</sup> equipped for terminating 100 or less lines, equipped for 4 circuits, each	\$3,150.00	\$4,735.00	\$292.60
(a) Arranged for 5th or 6th circuit	650.00	1,102.00	99.00
2. Rearranging concentrator-identifier jackstrips			
(a) To change the location of a concentrator-identifier jackstrip			
(1) Each 10-line jackstrip	-	25.00	-
(2) Each 20-line jackstrip	-	34.00	-
(3) Each line associated with the jackstrips			
- First line of an order	-	25.00	-
- Each additional line of an order	-	3.00	-
B. Concentrator-identifier system <sup>2</sup> arrangement(s) provided jointly with a connecting utility			
1. Identifier in an exchange of the Company			
(a) Identifier	800.00	848.00	222.75
- Arranged for 5 <sup>th</sup> and 6 <sup>th</sup> circuit	265.00	449.00	90.75
(b) Concentrator (refer to appropriate connecting Utility's Tariff and/or Product Guide)			

<sup>1</sup> The Company's ability to continue to provide this service is subject to the availability of replacement parts. The customer will be notified by certified mail within twenty-four (24) hours if replacement parts cannot be obtained. Coincident with this notification, customer billing for this service will cease.

<sup>2</sup> Plus appropriate mileage (transport) rate as shown in the Facilities for Intrastate Access Tariff C-1.

Effective: April 1, 2016

GENERAL SERVICES

TELEPHONE ANSWERING SERVICE (Continued)

IV. RATES AND CHARGES (Continued)

	<u>BTC</u>	<u>Nonrecurring Charge</u>	<u>Monthly Rate</u>
B. Concentrator-identifier system <sup>1</sup> arrangement(s) provided jointly with a connecting utility (Continued)			
2. Concentrator in an exchange of the Company			
(a) Concentrator (Capacity 6 trunks)			
(1) First 2 trunks	\$1,600.00	\$678.00	\$371.25
(2) Additional 2 trunks, each	-	297.00	41.25
(b) Identifier (refer to appropriate connecting Utility's Tariff and/or Product Guide)			
(c) Concentrator – Identifier trunks			
C. Concentrator (Candela) in Company central office - identification provided by customer on customer premises.			
1. Master concentrator equipped with line card for 32 client lines and 2 trunks.	3,079.00	5,000.00	400.00 <sup>2</sup>
(a) Additional 2 trunks, each set	370.00	300.00	50.00 <sup>2</sup>
(b) Line Card- 32 client terminations, each card	2,523.00	200.00	65.00
2. Slave concentrator <sup>3</sup> (maximum 2 per system) line card(s) required, each	2,620.00	3,000.00	175.00
3. Optional equipment			
- Data modem <sup>3</sup> (central office) for customized ring count	275.00	250.00	45.00 <sup>4</sup>

<sup>1</sup> The Company's ability to continue to provide this service is subject to the availability of replacement parts. The customer will be notified by certified mail within twenty-four (24) hours if replacement parts cannot be obtained. Coincident with this notification, customer billing for this service will cease.

<sup>2</sup> Plus mileage (transport) rate as shown in the Facilities for Intrastate Access Tariff C-1.

<sup>3</sup> See Special Condition O.7.

<sup>4</sup> Plus special access from the Facilities for Intrastate Access Tariff C-1.

Effective: April 1, 2016

GENERAL SERVICES

TELEPHONE ANSWERING SERVICE (Continued)

IV. RATES AND CHARGES (Continued)

	<u>Nonrecurring Charge</u>	<u>Monthly Rate</u>
D. Lines Terminating on Telephone Answering Serving Arrangements		
1. Answering lines		
(a) Each individual line appearing on a concentrator-identifier arrangement		
- Terminated on concentrator-identifier arrangement	\$ <sup>1</sup>	\$11.84 <sup>2</sup>
(b) Answering lines appearing on Company concentrator (Candela) in central office. Each line <sup>3</sup>	1	4.15 <sup>2</sup>
2. Secretarial lines		
(a) Each individual line appearing on a concentrator-identifier arrangement (refer to the Facilities for Intrastate Access Tariff C-1 for mileage (transport))		
- Terminated in concentrator-identifier arrangement	1	11.84
(b) Secretarial appearing on Company concentrator (Candela) in central office. Each line <sup>3</sup>	1	4.15
3. The following applies in Kenwood, Los Gatos, Morgan Hill and Novato		
- Answering line service different subscriber, each line	4	15.70

Rate applicable to business individual line service, whichever is less.

<sup>1</sup> Applicable charges in Section 3 of this Product Guide.

<sup>2</sup> Plus applicable business individual line rate.

<sup>3</sup> Facilities for Intrastate Access Tariff C-1 for applicable mileage (transport).

<sup>4</sup> Restricted to customers in service before July 19, 1989.

Effective: April 1, 2016

---

GENERAL SERVICES

SUPPLEMENTAL SERVICES

I. APPLICABILITY

Applicable to miscellaneous supplemental services. In addition to charges and rates specified herein, charges in Section 3 of this Product Guide are applicable.

II. TERRITORY

Within the exchange areas of all exchanges as said areas are defined on maps as part of this Product Guide.

III. SPECIAL CONDITIONS

A. Metering Service

1. General

- (a) Rate 1 contemplates that meters be located in the central office.
- (b) Metering service is furnished only when operating conditions and facilities permit and in accordance with engineering specifications and standard operating procedures of the Company.
- (c) Resettable or nonresettable meters will be provided based on the customer's requirements when considering the functional operation of the service with which the meters will be associated and whether or not the meters provided will meet the customer's service need.
- (d) Rearrangement of individual primary station and/or trunk line service and other classification of the line (i.e., tie line, private line, etc.) for which the service is adapted will be at the charge in the appropriate section of the Product Guide.

B. Rotary Control Arrangement

Rotary control arrangement stops rotary switching action in the central office at the predetermined number. The arrangement will permit a customer to restrict the number of incoming central office lines in rotary to a group smaller than that required during normal operation. Equipment located in the serving central office and connected to a predetermined number within the rotary group is activated by customer equipment at the customer's premises. Mileage charges as set forth in private line schedules apply to the channel between the customer premises and the central office.

GENERAL SERVICES

SUPPLEMENTAL SERVICES (Continued)

IV. RATES AND CHARGES

	<u>Nonrecurring Charge</u>	<u>Monthly Rate</u>
A. Metering Service - for use in central office with Centrex, DID and EBSS services. (See Special Condition A.)		
1. Meters, including housing (cabinet and/or mounting arrangement), using either resettable or nonresettable type.		
(a) Arrangement of six (6) or less, each meter		
- Centrex Service	\$37.00	\$2.95
B. Booths		
1. Indoor	339.00	25.30
2. Shelfette	16.00	4.70
3. Outdoor	339.00	25.30
4. Canopy	16.00	12.05
C. Coin telephone volume control handset (WE type G13) arranged to amplify on reception of voice signals, each	58.00	4.00
D. Pushbutton telephone service only arrangement to provide either "1" and "0", "1", or "0" level restriction.		
Electronic central office arrangement, dial pulse or touch calling, per line only		
1. "1" and "0" only	44.00	3.70
2. "1" only	44.00	3.70
3. "0" only	44.00	3.70
4. "1" and "0" only with WATS <sup>1</sup> calling capability	103.00	17.90
E. Toll and multi-message unit denial service and arrangement to permit access to the traffic service position system (TSPS) toll operator.	2	2
F. Rotary control arrangement for individual line services in Rotary, each unit (See Special Condition B).	55.00	2.85

<sup>1</sup> Wide Area Telecommunications Service (WATS) is grandfathered and limited to existing customers at existing locations as of January 13, 2005.

<sup>2</sup> See Section 12 of this Product Guide for applicable rates.

Effective: April 1, 2016

---

GENERAL SERVICES

INTEREXCHANGE RECEIVING SERVICE

I. APPLICABILITY

Applicable to interexchange receiving service.

II. TERRITORY

Within the exchange area of all exchanges, as said areas are defined on maps as part of this Product Guide.

III. SPECIAL CONDITIONS

A. Interexchange receiving service is available to customers to all types and grades of business services, including foreign exchange service located in the receiving exchange, excluding all coin box telephone services.

B. A customer subscribing to interexchange receiving service will be billed for all interexchange toll messages to him from those exchanges in which he subscribes for this service. The regular sent-paid station rate is applicable to each interexchange message.

C. A telephone number designation will be assigned to each service in each exchange in which the interexchange receiving service is subscribed for and will be listed in the telephone directory of that exchange as well as the receiving exchange. Only calls to this number originating from the exchange in which the service is subscribed for will come within the scope of service under this schedule and then only when the customer's telephone service, where calls are received, is not included in the local service area of the calling station.

D. Novato Exchange

Interexchange receiving service will not be furnished in connection with foreign exchange service.

IV. RATES AND CHARGES

	<u>Monthly Rate</u>
Each interexchange receiving service	\$56.00

Effective: April 1, 2016

---

GENERAL SERVICES

PRIVATE LINE SERVICES AND CHANNELS

I. APPLICABILITY

Applicable to miscellaneous supplemental services furnished in connection with private line services.

II. TERRITORY

Within the exchange areas of all exchanges as said areas are defined on maps as part of this Product Guide.

III. SPECIAL CONDITIONS

Conditions applicable to the supplemental services as shown for private line services other than teletypewriter service.

The furnishing of central office battery is subject to plant operating limitations and to the availability of suitable battery at a central office through which the channel normally operates. Where additional channel facilities are required in connection with the furnishing of central office battery rates and charges for a local channel will apply in addition to the rates for the battery tap.

IV. RATES AND CHARGES

	<u>Nonrecurring Charge</u>	<u>Monthly Rate</u>
Battery supply (See Special Condition above) <sup>1</sup>		
Each A.C. or D.C. battery tap, per channel	-	\$1.10

<sup>1</sup> Offering limited to service established prior to February 27, 1982.

Effective: November 18, 2018

---

GENERAL SERVICES

CONVENIENCE FEE

I. GENERAL

A convenience fee is a charge that is added onto a customer's account if a customer makes a payment using a Company Representative. The customer is informed by the Company Representative of the applicable charges prior to processing the payment. The charge will be collected at time of payment processing.

This fee will not apply if:

- The automated payment systems are unavailable due to system outages.
- At the time payment is made, the customer agrees to sign up for automatic bill payment.
- Payment is taken for a deposit.
- The payment is for a Government account.

II. RATES AND CHARGES

	<u>Nonrecurring Charge</u>	
Convenience Fee, per occurrence	\$10.00	(I)



Effective: December 12, 2019

---

GENERAL SERVICES

VACATION GET AWAY SERVICE

I. GENERAL

Vacation Get Away service provides for temporary discontinuance of service at the customer's request without termination of the service.

II. CONDITIONS

1. Vacation Get Away Service applies to customers of Residential Exchange Access Service as well as vertical features, bundles and other basic services. Vacation Get Away Service is not available for Lifeline customers. (C)
2. No outward or inward service is provided during the period of Vacation Get Away Service, except for 911 calls.
3. Vacation Get Away Service will not be made available for periods of less than two (2) months.
4. Vacation Get Away Service is available to a customer for a maximum period of nine (9) consecutive months. The customer's number must be working for at least 90 days in a calendar year.
5. During the period of Vacation Get Away Service, no installations, moves, changes or maintenance will be provided. Changes to billing address would be allowed.
6. The customer may request a restoration date in advance of the maximum allowable vacation period otherwise, complete service and billing will be restored on the last day of the maximum allowable vacation period of 9 months. A letter with the missed notifications will be sent to the customer at the time of restoral.
7. Monthly bills for services not covered by the Vacation Get Away Service during the vacation service period are to be paid in accordance with regular collection practices.
8. Vacation Get Away Service will be available where technically feasible.
9. Charges for Vacation Get Away Service will be a non-recurring charged to be billed in advance of the vacation service.

III. RATES

NONRECURRING CHARGE:

\$39.99

Effective: April 1, 2016

---

CUSTOM CALLING SERVICES

TABLE OF CONTENTS

	<u>SHEET NO.</u>
I. GENERAL	1
II. INDIVIDUAL CALLING SERVICES	3
A. Special Conditions	3
B. Rates and Charges	8
III. CALL RESTRICTION SERVICES	9
A. Special Conditions	9
B. Rates and Charges	11
IV. REMOTE CALL FORWARDING – Grandfathered as of November 16, 2013	12
A. Special Conditions	12
B. Rates and Charges	15
V. DIRECT CONNECT SERVICE	16
A. Special Conditions	16
B. Rates and Charges	16
VI. ENHANCED CALL FORWARDING	17
A. Special Conditions	17
B. Rates and Charges	20

Effective: April 1, 2016

---

CUSTOM CALLING SERVICES

I. GENERAL

- A. Custom Calling Services are exchange services and service order activity charges set forth in Section 3 of this guide are applicable when a feature or package is ordered, unless other work subject to installation charge or service connection charge is done at the same time on the same order. When a Custom Calling Service feature or package is ordered subsequent to the installation of its associated exchange line, the service order activity charges shall be waived for up to 60 days from the initial request for service.
- B. The features of Custom Calling Service require special central office equipment and will be provided only where facilities are available. Coincident with the offering of Sharper Call Pack<sup>1</sup>, the migration of existing services to this new package may deplete central office facilities, thereby delaying some customers from receiving all of the services until additional central office equipment is installed.
- C. Specific central office equipment programs are necessary to provide all the services included in the Sharper Call Packs<sup>1</sup>. Customers may subscribe to the Sharper Call Packs<sup>1</sup> in service areas that do not have the central office programs to provide all the package services or where computer memory is limited. These customers will receive all the Packaged Services when additional central office equipment and programs are installed/upgraded.
- D. Custom Calling Service features may be provided to customers with either dial or Touch Call Telephone Services.
- E. Custom Calling Service will not be provided in conjunction with Customer Owned Pay Telephones, Private Branch Exchange Trunk Line Service, Direct Inward Dialing Service or Cellular Service. Additionally, features listed under Custom Calling Service may not be compatible with exchange lines served by key system equipment.
- F. Provision of Custom Calling Services may be subject to the availability of SS7 signalling technology. These services are available only on calls placed to/from compatible central offices and only on calls which originate from lines capable of delivering the calling number or "private" indicator.
- G. Custom Local Area Signaling Service features are applicable to calls placed to/from compatible central offices or within a compatible central office offering the service. These services are offered based on information stored within the switch or provided to the switch through call setup signaling and are subject to limitations associated with the availability and content of that information.

<sup>1</sup> Sharper Call Pack is grandfathered and limited to existing customers at existing locations as of March 21, 2005. No moves, additions or changes will be permitted.

Effective: April 1, 2016

---

CUSTOM CALLING SERVICES

I. GENERAL (Continued)

H. Custom Calling Service

1. Custom Calling Service features are offered to single line residential and single line business customers subscribing to one party local exchange service with the exception that some individual features may be available to business customers with Rotary Service (see Section 4 for Rotary Service). If the feature is available with Rotary Service, it will be indicated in the specific description for that feature.
2. The service will be furnished only where facilities are available. Service is offered on a limited basis by specific switching systems within certain geographical areas. Since this service is not offered in all areas, it is important to verify its availability by contacting your Company Account Representative or Business Office at the telephone number listed in your telephone directory under the heading "WHERE TO REACH FRONTIER", for installation and/or service. Custom Calling Service features are applicable only to calls placed to/from compatible central offices.
3. Operator assisted calls are designed to override the feature calls for emergency purposes.
4. Nonrecurring charges are not applicable when Custom Calling Service features are provided at the same time as the business or residence individual line service is established.
5. When features are added or rearranged on an existing line, the nonrecurring charge will apply, except as noted in Section 3, Special Condition 2 and for Flexible Packaging<sup>1</sup> (see Section 7, Custom Calling Service).
6. Residential customers may be eligible for a discount if they subscribe to four or more individual Custom Calling Services. See Section 7, Custom Calling Service for a description of Flexible Packaging<sup>1</sup>.

I. Satisfaction Guarantee

If, at any time, the customer notifies the Company of any dissatisfaction with any of the Custom Calling Services, the customer will be entitled to a full refund of one (1) month's monthly recurring charge, or a prorated amount if subscription is less than 30 days. This refund will be applied as a credit on a subsequent bill after the service or feature is removed. Each customer will be entitled to the credit once per service.

The Satisfaction Guarantee will apply to all of the Custom Calling Services listed in this product guide.

<sup>1</sup> Flexible Packaging is grandfathered and limited to existing customers at existing locations as of March 21, 2005. No moves, additions or changes will be permitted.

Effective: April 1, 2016

---

CUSTOM CALLING SERVICES

II. INDIVIDUAL CALLING SERVICES

A. SPECIAL CONDITIONS

1. Call Forwarding

- a. Flexible Call Forwarding provides a subscriber with the ability to forward (transfer) incoming calls to another telephone number and to discontinue forwarding. Forwarding and restoral can be executed only from the customer's service.
- b. The quality of the transmission of calls forwarded may vary because of distances and the routes used to complete forwarded calls. Quality of transmission of a forwarded call is not guaranteed.
- c. Each customer subscribing to a call forwarding service is responsible for the payment of applicable charges for each completed call made between the line from which a call is forwarded and the line to which the call is forwarded. Local, ZUM, or message toll charges will be billed in accordance with the rates, terms, and conditions of the Company's Product Guide for the portion of a call forwarded.
- d. Call forwarding services are available to customers subscribing to Individual-Line Services, to Individual-Line Services arranged for rotary service, and to FGA services if facilities permit.
- e. A customer ordering services which forwards calls on a "no-answer" basis, must specify, for himself or on behalf of each client, the number of times the telephone rings before redirection under a no-answer condition. For each change of the number of rings, a subsequent order charge, as specified in Section 3, Service Charges for business customers, is billed to the customer.
- f. Call Forwarding is available with FGA Service as described in the Facilities for Intrastate Access Tariff C-1.

2. Call Waiting/Cancel Call Waiting

Call Waiting permits the customer engaged in a call to receive a tone signal indicating a second call is waiting, and by operation of the switchhook to place the first call on hold and answer the waiting call. The customer may alternate between the two calls by operation of the switchhook, but a three-way conference cannot be established. Cancel Call Waiting permits the customer before making a call to dial a code which will prevent the call waiting tone signal from interrupting for the next call only. The tone signal function will be automatically restored to the customer's line upon a disconnect.

Effective: April 1, 2016

---

CUSTOM CALLING SERVICES

II. INDIVIDUAL CALLING SERVICES (Continued)

A. SPECIAL CONDITIONS (Continued)

3. Speed Dialing<sup>1</sup>

Speed Dialing permits the customer to place calls to other telephone numbers by dialing a one- or two-digit code rather than the complete telephone number. The feature is available as an eight-code list or thirty-code list. Either code list may include local and/or toll telephone numbers. To establish or change a telephone number in a code list, the customer dials an activating code, receives a second dial tone and dials either a one- or two-digit code (for the eight-code and thirty-code lists, respectively) plus the telephone number.

Only one type of Speed Dialing may be provided on each line, either eight-code or thirty-code.

4. Three Way Calling

Three Way Calling permits the customer to add a third party to an established connection by depressing the telephone hookswitch (or an incorporated "flash" button). When the third party answers, a two way conversation can be held before adding the original party for a three way conference. The customer initiating the conference controls the call and may disconnect the third party to reestablish the original connection or establish a connection to a different third party. The feature may be used on both outgoing and incoming calls.

This feature is offered on a per line or per occurrence basis. When Three Way Calling is activated on a per occurrence basis, the per occurrence rate applies each time the feature is activated, up to 10 occurrences per month. Provision of the per occurrence option of this feature may be blocked at the request of the customer free of charge.

Customers can receive a one time adjustment for charges when a customer claims unknown, unauthorized or denied use of the service by calling their Company Billing Representative at the telephone number listed in their telephone directory under the heading, "WHERE TO REACH FRONTIER", for billing. Frontier will arrange for the service to be "blocked" at the customer's request.

5. Distinctive Ring<sup>1</sup>

Distinctive Ring provides the customer with two separate telephone numbers on one line, each with its own distinct ring for call differentiation. A directory listing may be established on the second number at no charge.

<sup>1</sup> Effective November 16, 2013, residence Speed Dialing and Distinctive Ring are no longer available for purchase. Existing customers of record may retain this service at existing locations in accordance with the terms and conditions described herein. Service is not offered for new installations, moves, changes, or additions.

---

CUSTOM CALLING SERVICES

II. INDIVIDUAL CALLING SERVICES (Continued)

A. SPECIAL CONDITIONS (Continued)

6. Busy Redial<sup>1</sup>

Busy Redial is an arrangement which permits the customer to redial automatically the last number dialed. If the called line is found to be busy, a 30 minute queuing process begins. The customer is then given an indication that the network will attempt to set up the call when the called line is idle. The network periodically tests the busy/idle status of the called line until both lines are found idle, the customer cancels the request, or the queuing process expires. If both lines are found to be idle, the calling party is alerted with a distinctive ring signifying that the call can now be completed.

The pay per use charge is activated irrespective of whether the call is completed or not. Pay per use customers will be charged upon dialing the activation code without any specific prior request for the feature.

7. Select Call Forwarding<sup>1</sup>

Select Call Forwarding is an arrangement which permits a customer to pre-specify a maximum of 12 telephone numbers from which incoming calls are to be forwarded. During the period that Select Call Forwarding is activated, only calls from the pre-specified numbers will be forwarded.

8. Call Block

Call Block allows a customer to block incoming calls from a maximum of twelve (12) numbers. The customer can also block incoming calls placed from the last calling number even if the number is unknown to the customer. The automatic voiceback feature has been disabled and will not voiceback the calling party's telephone number. Blocked calls are routed to a recorded announcement which specifies that the called party is not accepting calls. Callers diverted to the recorded announcement will not be billed usage charges.

9. \*69<sup>1</sup>

\*69 allows a customer to automatically return the last incoming call whether it is answered or not. Upon activation of this feature, the number of the most recent party who called will be automatically dialed. If the called line is busy, a 30 minute queuing process begins. The customer is given an indication that the network will attempt to set up the call when the called line is idle. The network will periodically test the busy/idle status of both parties until both lines are found idle, the customer cancels the request, or the queuing process expires. If both lines are found to be idle, the customer is alerted with a distinctive ring signifying that the call can now be completed. When \*69 is activated on a per occurrence basis, the per occurrence rate applies each time the feature is activated, regardless of whether the return call is completed to the calling party. Provision of the per occurrence option of this feature may be blocked at the request of the customer. Calls initiated by \*69 will appear on the subscriber's billing record by area code and prefix only. The calling party's number will not be announced to the \*69 customer.

The pay per use charge is activated irrespective of whether the call is completed or not. Pay per use customers will be charged upon dialing the activation code without any specific prior request for the feature.

<sup>1</sup> Effective November 16, 2013, residence Busy Redial, Select Call Forwarding and \*69 are no longer available for purchase. Existing customers of record may retain these services at existing locations in accordance with the terms and conditions described herein. Service is not offered for new installations, moves, changes, or additions.

---

CUSTOM CALLING SERVICES

II. INDIVIDUAL CALLING SERVICES (Continued)

A. SPECIAL CONDITIONS (Continued)

10. Call Trace

Call Trace allows a customer to automatically activate a trace record of the last incoming call. By activating the call trace feature, the customer automatically authorizes the Company to store the results of any and all traces initiated by the customer in the Company's switching office, and to release the results of such traces directly to the customer's serving law enforcement agency upon a further written request by the customer. The results of such traces will be released to the appropriate law enforcement agency only upon such further written request by the customer. The customer acknowledges his understanding that under no circumstances will trace results be provided directly to the customer.

The customer must contact the Company within ten (10) days after activating a call trace or the trace record will be automatically deleted.

Call Trace is available on a monthly subscription basis, or on a pay per use basis. Pay per use customers will be charged upon dialing the activation code without any specific prior request for the feature.

11. Caller ID

Caller ID provides for the display of an incoming name and telephone number on a customer provided display device which is associated with the customer's local exchange service. Service can be provided to customers subscribing to rotary service. The Caller ID feature will forward the calling name and number from the appropriately equipped central office to the customer provided display device, typically by the second ring. The Company will forward non-blocked names and telephone numbers (including Nonpublished and Nonlisted telephone numbers) subject to limitations, such as those described below. Anonymous Call Block is included with this service at no additional cost where facilities and conditions permit.

The name and telephone number of the caller may not be displayed for every incoming call. "Out of Area," "Unavailable," the calling party's state name, or a similar message may appear for certain calls, including (i) calls made through certain networks, (ii) operator-assisted calls, calls from toll-free numbers, calling card calls, and international calls, (iii) when phone number or caller name information is not made available to Frontier, (iv) for certain telephone numbers for which Frontier does not purchase Caller ID information, and (v) for other technical reasons. In addition, "Private," "Anonymous" or a similar message may appear when the caller has blocked caller identification information.

All customer provided equipment used to interface with Caller ID must be connected in accordance with the provisions of the Federal Communications Commission's Registration program. Any intent to sell name(s) and/or number(s) gathered as a result of Caller ID is prohibited. This service is available only where facilities and conditions permit.



---

CUSTOM CALLING SERVICES

II. INDIVIDUAL CALLING SERVICES (Continued)

A. SPECIAL CONDITIONS (Continued)

12. Anonymous Call Block

Anonymous Call Block allows a customer to reject calls from callers who have activated a blocking option in order to prevent the display of their telephone number. Anonymous Call Block is activated or deactivated by dialing a preassigned code. When Anonymous Call Block is activated, such calls will be routed to an announcement which tells the caller that the called party will not accept calls from callers who have chosen to prevent the display of their telephone numbers. The calling party will be requested to hang up and place the call again without the blocking feature activated. Callers will not be charged for incomplete calls due to Anonymous Call Block.

13. Call Waiting ID

Call Waiting ID enhances Caller ID and Call Waiting by allowing them to interact with one another. With the interaction of the features, the Caller ID customer can receive Caller ID information, unless the caller blocks the display of name and/or number or the information is unavailable due to technical reasons. The customer must subscribe to both services (Caller ID - Only or Caller ID and Call Waiting). Call Waiting ID Compatible Display equipment is required. (NOTE: Current Name and Number, Type 1 CPE, that is only Caller ID compatible will not work with this service.)

Customers who call to set up the Call Waiting and Caller ID interaction will not be charged applicable Section 3 Service Order charges. Customers who call to subscribe to Caller ID and/or Call Waiting in order to receive the enhanced interaction will be charged the applicable Section 3 Service Order charges.

14. Selective Blocking - Per Call provides free per-call blocking. Customers may prevent the delivery of their name and/or telephone number to the called party on a call by call basis. This is accomplished on a per call basis when the customer dials the Selective Blocking - Per Call activation code prior to placing the call. Selective Blocking does not prevent delivery of names and/or telephone numbers when services that utilize Automatic Number Identification (ANI) are called (e.g., 0+, 0-, 700/800/877/888/900 and 911 Services).

15. Complete Blocking - Per Line provides free per-line blocking. The service prevents the delivery of the customer's name and/or telephone number to the called party. A Complete Blocking - Per Line customer has the option of deactivating the blocking feature and forwarding their name and/or telephone number on a per call basis by dialing a code prior to placing the call. Complete Blocking does not prevent delivery of names and/or telephone numbers when services that utilize Automatic Number Identification (ANI) are called (e.g., 0+, 0-, 700/800/877/888/900 and 911 Services).

Effective: May 1, 2024

CUSTOM CALLING SERVICES

II. INDIVIDUAL CALLING SERVICES (Continued)

B. RATES AND CHARGES

	<u>Monthly Rate</u>		<u>Pay Per Use</u>	
	<u>Business</u>	<u>Residence</u>	<u>Business</u>	<u>Residence</u>
1. Flexible Call Forwarding	\$7.75	\$9.00 <sup>3</sup>		
2. Call Forwarding Rotary	7.50			
3. Call Forwarding Busy-Line—Fixed <sup>7</sup>	7.50	8.50 <sup>3</sup>		
4. Call Forwarding No-Answer—Fixed <sup>7</sup>	7.75	8.50 <sup>3</sup>		
5. Call Forwarding Busy Line Don't Answer	8.25	8.50 <sup>3</sup>		
6. Call Waiting / Cancel Call Waiting	15.75 (I)	9.50 <sup>3</sup>		
7. Speed Dialing - Eight-code capacity <sup>7</sup>	3.50	6.00 <sup>3</sup>		
8. Speed Dialing - Thirty-code capacity <sup>7</sup>	4.50	7.25 <sup>3</sup>		
9. Three Way Calling	9.00	10.00 <sup>3</sup>	\$3.00 <sup>4,5</sup>	\$3.00 <sup>4,5</sup>
10. Distinctive Ring <sup>7</sup>	8.50	11.00		
11. Busy Redial <sup>6,7</sup>	5.00	7.50	3.00 <sup>4,5</sup>	3.00 <sup>4,5</sup>
12. Select Call Forwarding <sup>6,7</sup>	6.00	6.25		
13. Call Block	--	5.00		
14. Call Trace <sup>6</sup>	6.00	5.50	6.00	6.00
15. *69 <sup>6,7</sup>	6.25	9.25 <sup>3</sup>	3.00 <sup>4,5</sup>	3.00 <sup>4,5</sup>
16. Caller ID	19.00 (I)	12.25		
17. Anonymous Call Block <sup>1</sup>	4.00	6.00		
18. Call Waiting ID <sup>2</sup>	1.50	0.00		
19. Selective Blocking, per call <sup>6</sup>	0.00	0.00		
20. Complete Blocking <sup>6</sup>	0.00	0.00		

<sup>1</sup> Appropriate nonrecurring charges as set forth in Section 3, Service Charges, apply.

<sup>2</sup> Rates for Caller ID and Call Waiting/Cancel Call Waiting apply in addition to this rate. See Special Conditions A.13.

<sup>3</sup> To be implemented on a full bill period basis on or after November 16, 2013.

<sup>4</sup> Application of the per occurrence charge for this service is limited to the first ten (10) occurrences per month.

<sup>5</sup> Provision of the per occurrence option of this feature may be blocked at the request of the customer.

<sup>6</sup> Flexible Rate Ranges have been established for this service.

<sup>7</sup> Effective November 16, 2013, these services are no longer available for purchase. Existing customers of record may retain these services at existing locations in accordance with the terms and conditions described herein. Service is not offered for new installations, moves, changes, or additions.

Effective: April 1, 2016

---

CUSTOM CALLING SERVICES

III. CALL RESTRICTION SERVICES

A. SPECIAL CONDITIONS

1. Call Restriction Option I
  - a. Restricts outgoing calls to the local calling area plus the local-extended calling area.
  - b. Permits the customer and/or users of the service to access certain operator assisted calls, which include repair service, directory assistance and emergency service operators.
  - c. Denies access to ZUM Zone 3 calling area, toll calls, third party billing, "0" minus and "0" plus calls.
  - d. Will only be provided from selected electronic central office switches and then only where such facilities are available.
  - e. Charges for all incoming calls (including collect calls) shall be the responsibility of the customer.
  - f. It is the customer's responsibility to inform the Company of any failures of the feature to perform as specified herein.
2. Call Restriction Option II - TSPS Screening
  - a. Will only be provided from selected electronic central office switches and then only where such facilities are available.
  - b. May require telephone number change.
  - c. Will allow third number calls, collect calls, local exchange or interexchange carrier calling card calls, operator assisted calls to 611, 711 and 911 and will allow assist calls placed by handicapped who are unable to dial.
  - d. Will deny incoming collect calls and third party billing to this service.
  - e. Will deny time and charge requests.
  - f. Provides operator interactive screening for intraLATA calls only. Screen code customers are required to make screening arrangements with appropriate interexchange carriers for calls placed outside the LATA.
  - g. It is the customer's responsibility to inform the Company of any failures of the feature to perform as specified herein.
  - h. Traffic Service Position System (TSPS) screening will not be provided in conjunction with Foreign Exchange Service, except those Foreign Exchange lines provided to Pacific Bell Remote Island Areas and will not be provided in conjunction with Centrex Service.

Effective: April 1, 2016

---

CUSTOM CALLING SERVICES

III. CALL RESTRICTION SERVICES (Continued)

A. SPECIAL CONDITIONS (Continued)

3. Option III – Split 1+DDD Restriction
  - a. Block calls to 101XXXX+1+ and 101XXXX+011+.
  - b. Split 1+DDD Blocking is offered to aggregators upon request, on a per line or trunk basis. An aggregator is any individual, partnership, association, joint-stock company, trust or corporation that, in the ordinary course of its operations, makes telephones available to the public or to transient users of its premises.
4. Option IV – Call Restriction
  - a. Restricts directly dialed calls to the local calling area plus the local extended calling area.
  - b. Allows 0- and 0+ calls.
5. Option V – 1+ and 0+(900)XXX-XXXX and 976-XXXX Blocking
  - a. Option V blocking prevents the completion of directly dialed intrastate 976-XXXX and all directly dialed Intrastate 1+ and 0+(900)XXX-XXXX calls where a subscriber is served from a technically capable central office.
  - b. Call Restriction Option V is available to all individual-line and trunk-line customers.
  - c. A residential or business subscriber served from a central office in which blocking cannot be provided may change telephone numbers to be served by a co-located central office for the purpose of obtaining Option V blocking and shall not be charged for the number changed.
  - d. Option V blocking shall be reinstalled for a fee upon request from the residence or business customer.
  - e. Businesses subscribing to Option V blocking will incur no charge if the blocking order is placed at the same time as an initial order or if a blocking or unblocking order is placed at the same time as a subsequent order for other service changes. This charge will be reduced to \$1.00 if the blocking order is placed no more than 60 days after customer receipt of a bill insert announcing the offer.
  - f. Option V blocking shall be removed for a fee upon written request from the residence customer.
  - g. Option V blocking shall be removed for a fee upon request from the business customer.
  - h. For those residence customers who request Option V, blocking, the one-time per-line charge specified in RATES Section will be tracked in a memorandum account in lieu of application to the customer's bill.

This charge does not apply to residence Universal Lifeline Telephone Service customers.
6. Call Restriction Service will be furnished only where facilities are available. Service is offered on a limited basis by specific switching systems within certain geographical areas. Since this service is not offered in all areas, it is important to verify its availability by contacting your Company Account Representative or Business Office at the telephone number listed in your telephone directory under the heading "WHERE TO REACH FRONTIER", for installation/service.

Effective: April 1, 2016

CUSTOM CALLING SERVICES

III. CALL RESTRICTION SERVICES (Continued)

B. RATES AND CHARGES

	<u>Nonrecurring Charge</u>	<u>Monthly Rate</u>	
		<u>Business</u>	<u>Residence</u>
1. Option I - Allows calling within the local exchange and local extended calling area		\$5.00	\$3.50
2. Option II - Provides operator interactive OSPS screening and BNS	\$23.00	3.50	3.50
3. Option III - Split 1+DDD Restriction	26.00	5.00	5.00
4. Option IV - Allows sent paid calling to local calling area and EAS only, allows 0+ and 0- access		3.00	3.00
5. Option V - 1+ and 0+(900)XXX-XXXX and 976-XXXX Call Blocking		<u>Nonrecurring Charge</u>	
		<u>Business</u>	<u>Residence</u>
a. Blocking of Intrastate 976-XXXX and Interstate/Intrastate 1+ and 0+(900) XXX-XXXX calls when the subscriber elects to have such calls blocked, per line	\$15.00 <sup>1, 2</sup>	\$0.00 <sup>1, 3</sup>	
b. Removal of service per line	15.00 <sup>1</sup>	5.00 <sup>1</sup>	
c. Reinstallation of service per line	15.00 <sup>1</sup>	5.00 <sup>1</sup>	

<sup>1</sup> This charge will not apply if the blocking order is placed at the same time as an initial order or if a blocking or unblocking order is placed at the same time as a subsequent order for other service changes.

<sup>2</sup> Excluding Centrex-type customers.

<sup>3</sup> For residence customers who request blocking of call attempts to 1+ and 0+(900)XXX-XXXX and 976-XXXX telephone numbers (Option V blocking), the one-time per-line charge specified in RATES Section will be tracked in a memorandum account in lieu of application to the customer's bill. This charge does not apply to Universal Lifeline Telephone Service.

Effective: April 1, 2016

---

CUSTOM CALLING SERVICES

IV. REMOTE CALL FORWARDING SERVICE<sup>1</sup>

A. SPECIAL CONDITIONS

1. Description of Service

Remote Call Forwarding Service (RCF) is a service which includes the furnishing of a local network address (telephone number) to a customer, which automatically forwards (transfers) all incoming calls to another network address in a different exchange, to a network address in another wire center (central office) in the same exchange or to a network address in the same wire center.

2. Remote Call Forwarding Service will be provided subject to the following limitations:

- a. The network address must be located in a central office where the required special equipment and facilities are available.
- b. The customer is not required to have telephone service in the exchange where the Remote Call Forwarding Service is furnished.
- c. The service does not include an access line or a telephone set.
- d. The service is not offered where the terminating equipment is a coin/coinless service station.
- e. The quality of transmission of calls, which are forwarded, may vary depending on the distance and the routing necessary to complete each call, and normal transmission is not guaranteed on any forwarded call.
- f. The service is not represented as suitable for transmission of data or for connection to other services beyond the premises of the terminating primary station.
- g. The minimum service period is one month.
- h. Customers of the service are subject to Schedule No. D&R, Rule No. 9 in the General Exchange Tariff, and must pay all applicable charges.
- i. Customers shall not use RCF service to avoid toll charges. This means that a customer shall not, among other things, use RCF service to forward a call to another carrier so that the call, which would otherwise be routed and rated as a toll call, is instead routed and rated as two or more local calls.
- j. Neither Call Forwarding nor Remote Call Forwarding Service will be offered at the answering location.

<sup>1</sup> Effective November 16, 2013, residence Remote Call Forwarding Service is no longer available for purchase. Existing customers of record may retain this service at existing locations in accordance with the terms and conditions described herein. Service is not offered for new installations, moves, changes, or additions.

Effective: November 10, 2020

---

CUSTOM CALLING SERVICES

IV. REMOTE CALL FORWARDING SERVICE<sup>1</sup> (Continued)

A. SPECIAL CONDITIONS (Continued)

2. Remote Call Forwarding Service will be provided subject to the following limitations: (Continued)
  - k. Due to technical limitations related to the Caller ID Privacy Indicator, the Company will not provide identification of the calling party number to the RCF customer.
  - l. Each RCF Service allows for forwarding one call at a given time. An additional service is necessary for each additional call to be forwarded simultaneously.
  - m. The answering location for a forwarded call cannot be an international telephone number.
  - n. Remote Call Forwarding Service may be discontinued if a customer violates special conditions (i), (j) and (l) after 10 days from the issuance of written communication from the Company.
3. RCF Service will only be provided when the customer subscribes to sufficient RCF Service at the answering location to adequately handle calls without interfering with or impairing any services in accordance with Schedule No. D&R, Rule No.10.L. Impairment of Service in the General Exchange Tariff.
4. Message Charges
  - a. Remote Call Forwarding Service<sup>1</sup> is provided on a measured rate basis only for existing customers only. Any new customers or additional lines will be on a flat rate basis. (C)  
(C)
  - b. Existing customers will pay the RCF rate and either local usage charges or message toll telephone service charges based on the following: (C)
    - (1) If the forwarding location number is not in the same exchange or same local calling area of the called number, message toll charges are applicable from the called number to the forwarding location number.
    - (2) If the forwarding location number is located in the same exchange or same local calling area of the called number, local usage charges are applicable from the called number to the forwarding location number.
  - c. Flat rate and measured message charges for forwarded calls may be comprised of two separate usage charges: (C)  
(C)
    - (1) A charge for that portion of the call from the originating station to the RCF location, if applicable, billed to the originating station at rates shown in Section 4, Measured-Rate Service - Local Calling Rates.
    - (2) The dial station or 800 service charge for that portion of the call from the RCF location to the terminating station designated by the customer.

<sup>1</sup> Effective November 16, 2013, measured Remote Call Forwarding Service is no longer available for purchase. Existing customers of record may retain this service at existing locations in accordance with the terms and conditions described herein. Service is not offered for new installations, moves, changes, or additions. (C)

Effective: November 10, 2020

---

CUSTOM CALLING SERVICES

IV. REMOTE CALL FORWARDING SERVICE <sup>1</sup> (Continued)

A. SPECIAL CONDITIONS (Continued)

4. Message Charges (Continued)

- d. For flat rate and measured service, the respective charge for each portion of (1) and (2) shall be the rate specified in the appropriate section of this guide. (C)

(1) On all Operator-assisted calls, other than collect, the originating station is charged for the respective Operator-assisted rate for the portion of the call described in (1) preceding. The call forwarding customer is charged the dial station or 800 service rate for that portion of the call described in (2) preceding, even though such calls might not be accepted at the answering location.

(2) On a collect call, the collect charges apply to the portion of the call between the originating station and the Remote Call Forwarding location. The dial station or 800 service charge applies to the portion of the call described in (2) preceding, even though such calls might not be accepted at the answering location.

- e. Remote Call Forwarding Service will not be provided in conjunction with an unlimited usage toll plan.

5. Directory Listings

A listing in the alphabetical section of the directory covering the exchange in which Remote Call Forwarding Service originates is provided without additional charge. Additional listings will be provided in accordance with Section 21 of this Product Guide.

6. Network Access

- a. The network address (telephone number) of the Remote Call forwarding service is established by the Company at the time of the establishment of service, and at charges equal to those for an individual business line shown in Section 4, Local Exchange Service.

- b. The network address of the Remote Call Forwarding service number and the network address of the service arrangement to which calls are forwarded may be changed at the charges for a telephone number change for an individual business line as shown in Section 3, Service Charges.

Effective November 16, 2013, measured Remote Call Forwarding Service is no longer available for purchase. Existing customers of record may retain this service at existing locations in accordance with the terms and conditions described herein. Service is not offered for new installations, moves, changes, or additions. (C)



Effective: November 10, 2020

---

CUSTOM CALLING SERVICES

IV. REMOTE CALL FORWARDING SERVICE <sup>1</sup> (Continued)

A. SPECIAL CONDITIONS (Continued)

7. Limitation of Liability

Provisions covering limitation of liability and allowance for interruptions in service set forth in Section 2 of this Product Guide for exchange telephone service shall apply to this service.

8. It is the responsibility of the Remote Call Forwarding applicant to obtain permission of a third party to whom the calls are forwarded. General Exchange Tariff, Schedule No. D&R, Rule No. 10, prohibits interference of telephone service of another customer.

B. RATES AND CHARGES

	Nonrecurring Charge		Monthly Rate
	<u>Business</u>	<u>Residence</u>	
1. Initial Path	--	--	
Business			\$34.00
Residence			25.00
2. Each Additional Path	--	--	
Business			34.00
Residence			25.00

<sup>1</sup> Effective November 16, 2013, measured Remote Call Forwarding Service is no longer available for purchase. Existing customers of record may retain this service at existing locations in accordance with the terms and conditions described herein. Service is not offered for new installations, moves, changes, or additions

(C)

Effective: July 7, 2016

---

CUSTOM CALLING SERVICES

V. DIRECT CONNECT SERVICE

A. SPECIAL CONDITIONS

1. Direct Connect Service provides a customer with a one-way automatic connection to a designated number by lifting the receiver (i.e., a "hot line" or bring downs circuit). This service is available to Business Measured Service, Residence Flat/Measured Service/ California Lifeline Telephone Program, and Foreign Exchange Service. (T)
2. With Direct Connect Service:
  - a user can be "directly connected" to a predetermined number without dialing.
  - a user can receive incoming calls but cannot make outgoing calls.
  - there is no dial tone.
3. The predetermined number that calls are forwarded to may be local, long distance, lines in Rotary, FX, or an Answering Service. If forwarded to a long distance number, applicable long distance charges apply. If forwarded from a measured line to a local number, applicable local usage charges apply.
4. The Direct Connect Service line may be separately billed or combined with other like services.

B. RATES AND CHARGES

	<u>Nonrecurring Charge</u>		<u>Monthly</u>
	<u>Business</u>	<u>Residence</u>	<u>Rate</u>
Designated number	\$30.00 <sup>1</sup>	\$5.00 <sup>1</sup>	\$5.00

<sup>1</sup> This charge is in addition to the normal Section 3 charges applicable when establishing service.

---

CUSTOM CALLING SERVICES

VI. ENHANCED CALL FORWARDING

A. SPECIAL CONDITIONS

1. General

- a. Enhanced Call Forwarding (ECF) is an Advanced Intelligent Network (AIN) based call forwarding service designed to increase personal mobility.
- b. Enhanced Call Forwarding is furnished only from central offices which have been arranged to provide this service. ECF is provided subject to the availability of facilities.
- c. Enhanced Call Forwarding is available to Business Individual Lines and Centrex customers.

2. Description Of Service

- a. ECF customers can forward their number from any touch call phone via a toll-free number. Calls can be forwarded to any dialable pager, cellular phone, work phone, or home phone.
- b. ECF can be provided on the customer's existing telephone number as long as the customer's existing line resides behind an AIN capable switch, or via a personal number. This number is referred to as a default number.
- c. A personal number is a telephone number that does not have any actual line equipment tied to the number. This is a new number that is provided to the customer at initial subscription to ECF. At subscription, customers must designate what number their calls will route to, then customers may program ECF to route their number to any location at any given time.
- d. ECF will be offered as follows:

Enhanced Call Forwarding includes:

- The customer's existing number or a personal number can be used
- (3) Speed Forward Numbers
- Timed Forwarding

Enhanced Call Forwarding with Call Manager includes:

- The customers existing number or a personal number can be used
- (3) Speed Forward Numbers
- Timed Forwarding
- Automatic Forwarding
- Two schedules (normal and alternate)
- Two call acceptance lists with 20 number capacity each
- Two four-digit Caller Codes

---

CUSTOM CALLING SERVICES

VI. ENHANCED CALL FORWARDING (Continued)

A. SPECIAL CONDITIONS (Continued)

3. Definitions And Features

Automatic Forwarding - This feature allows customers to route calls automatically to the number they are dialing from. The system picks up the Calling Party's Number (CPN) from the calling phone. By using a feature code, customers can route their calls to the number where they are located at. When CPN is provided, the number the customer is calling from is not needed; the system will automatically route the call.

This is dependent on the CPN being provided. If no CPN is provided, the caller will need to manually enter the number. Calls placed from PBXs and key systems will not activate Automatic Forwarding correctly if DID or DOD trunks are utilized.

Call Acceptance List - This feature can be used by the customer to allow only calls from designated locations to reach him. Two call acceptance lists, each with 20 number capacity, are included with ECF. The customer receives calls from the people with whom he wishes to speak, and all other calls will be routed to the default number.

Caller Codes - Caller codes are provided as a way to bypass the call acceptance list. If the customer does not want to add every number to the list, he can give out one of two four-digit codes to his callers. The caller enters the code for the call to be routed to the customer. This also allows for an alternative access in case a caller is not calling from his usual number or the CPN is not carried through the call.

Speed Forward Numbers - Speed Forward Numbers are provided as a convenience to the customer. With speed forward numbers, the customer can preprogram up to three numbers to allow for easier redirecting later.

Time-of-Day/Day-of-Week Scheduling - Customers can route all incoming calls to them based on their daily activities. The schedule's primary function is to create the "follow-me wherever I go" functionality. The customer can call the administrative number at any time to route calls elsewhere if he deviates from his schedule. Two Time-of-Day/Day-of-Week schedules are included with ECF to give more flexibility to the customer.

Timed Forwarding - Timed Forwarding allows the customer to route calls for a specified time period to another location.

Effective: April 1, 2016

---

CUSTOM CALLING SERVICES

VI. ENHANCED CALL FORWARDING (Continued)

A. SPECIAL CONDITIONS (Continued)

4. Conditions

- a. Enhanced Call Forwarding is provided subject to the availability of technology and facilities.
- b. ECF will not be available on PBX trunks or DID/DOD trunks; or available to Customer-Owned Pay Telephone (COPT) Coin Line Service.
- c. The ECF customer is responsible for any applicable long distance, Extended Area Service, and/or Frontier Calling Plans charges when calls to the ECF number are redirected to a number outside the local calling area. When a customer's ECF number is forwarded to a cellular phone, normal air time charges will apply on the redirected call.
- d. When a Caller Code is entered and if the call acceptance lists(s) is activated, a call to the ECF subscriber is considered complete if the ECF subscriber utilizes answer supervision, even if the forwarded call is not answered. Applicable long distance and/or outside the local calling area (as identified in c. above) charges will apply to the caller.
- e. ECF will not be offered on lines equipped with Special Call Forwarding or Remote Call Forwarding. Special Call Forwarding and Remote Call Forwarding must be removed from the customer's line before adding ECF. ECF is not available as a substitute for Remote Call Forwarding.
- f. Except where facilities permit, ECF cannot be used to forward to locations requiring an international dialing format.
- g. ECF cannot be used to forward to 900/976/700 numbers. These numbers will be blocked to the ECF subscriber.
- h. Where ECF is provided on a service also subscribing to Call Restriction Service which prevents 1+ dialing, the ECF feature can be programmed to forward to a 1+ location at the customer's request. ECF will take precedence over the Call Restriction feature in such circumstance, and the subscriber will be responsible for the appropriate long distance and/or outside the local calling area charges for such calls.
- i. Customers who select a personal number will be provided one directory listing in their ECF central office exchange without charge. Additional directory listings may be obtained as specified in Section 21 of this Product Guide.

Effective: April 1, 2016

---

CUSTOM CALLING SERVICES

VI. ENHANCED CALL FORWARDING (Continued)

B. RATES AND CHARGES

	Monthly Rates <u>Business</u>
1. Enhanced Call Forwarding	
a. Existing Number	\$11.00
b. Personal Number	17.25
2. Enhanced Call Forwarding with Call Manager	
a. Existing Number	13.35
b. Personal Number	20.50

Effective: January 19, 2021

---

BUNDLED/ PACKAGED SERVICES

TABLE OF CONTENTS

	<u>SHEET NO.</u>	
Custom Call Plus (CCP) Feature Package	1	
150 Satellite Channel Programming PAC	3	
FTR Business Pack	5	
Unlimited Local Usage for Business/ Unlimited Local and Toll Usage for Business	7	
Unlimited Business Access (B1) Line and Unlimited Communications System Packages – Grandfathered as of March 17, 2012	12	
Basic Bundle – Grandfathered as of March 7, 2014	18	
Complete Package – Grandfathered as of February 14, 2014	19	
FTR Calling Feature Packages – Grandfathered as of February 14, 2014 and March 7, 2014	20	
Frontier Local Package/ Local and Toll Package/ Frontier Local Package Extra/ FTR Regional Package Unlimited/ FTR Regional Calling Plan/ Frontier Regional Value	22	
I. Special Conditions	22	
II. Frontier Local Package – Grandfathered as of November 16, 2013	23	
III. Local and Toll Package – Grandfathered as of March 21, 2005	24	
IV. Frontier Local Package Extra - Grandfathered as of November 16, 2013	25	
V. FTR Regional Package Unlimited – Grandfathered as of November 16, 2013	26	
VI. FTR Regional Calling Plan	27	
VII. Frontier Regional Value	28	
FTR Regional Essentials Discount – Grandfathered as of November 1, 2008	29	
FTR Regional Essentials Discount I	30	
Frontier® FiberOptic Internet Internet Bundle Discount – Grandfathered January 17, 2010	31	(C)
Frontier® FiberOptic Internet Internet Bundle Discount I	33	(C)
Home Voice Mail Packaged Offerings	34	
Frontier Local Package Basic/ Prime - Grandfathered as of November 16, 2013	35	
FTR Regional Calling Plan/ FTR Regional Select Discount – Grandfathered as of April 17, 2011	38	
Single Line Business Pak – Grandfathered as of March 17, 2012	39	

Effective: May 23, 2021

---

BUNDLED/ PACKAGED SERVICES

TABLE OF CONTENTS

	<u>SHEET NO.</u>	
FTR Regional Select Discount – Grandfathered as of march 16, 2013	43	
FTR Regional Calling Plan	44	
FTR Solutions for Business Bundle - Grandfathered	45	
Frontier Commercial Voice Unlimited – Grandfathered as of December 20, 2017	52	
Frontier OneVoice	54	
Frontier Residential Unlimited Voice Service	56	
Frontier Unlimited Voice and Feature Bundle	58	(N)



Effective: April 1, 2016

---

BUNDLED/ PACKAGED SERVICES

CUSTOM CALL PLUS FEATURE PACKAGE

I. SPECIAL CONDITIONS

A. Custom Calling Plus (CCP) is a service offering comprised of a group of features individually described below, which allow customers to effectively manage call flow. Call management is accomplished by the central office deployment of a technology which routes the calling party's telephone number from the central office originating the call to the terminating central office serving the called party. CCP will be provided from central offices have the generic capability.

B. Feature Description

Repeat Call - automatically redials the last outgoing telephone number dialed by the customer by dialing a code, providing there have been no intervening outgoing calls. If it is busy, the central office will continue trying the number until both parties are idle and then the central office will ring the customer.

Priority Call<sup>1</sup> - provides a way to distinguish up to a maximum of twelve calling telephone numbers from all others by using a distinctive alerting signal. Call Waiting customers hear a distinctive call waiting tone when special callers call during another conversation.

Select Call Forwarding - provides customers with a way to forward incoming calls from up to a maximum of twelve (12) calling telephone numbers to another telephone number.

Call Block<sup>1</sup> - allows the customer to automatically block incoming calls from twelve preselected telephone numbers specified by the customer. Calls can be blocked from selected telephone numbers or a number from which a customer has just received a call. The list of numbers may be changed by the customer any time. Call Block routes calls to a standard announcement stating, "The number you have dialed is not accepting calls at this time. Please try again." Toll charges or local usage charges will not apply to the calling party's number whose call is blocked. Pursuant to Ordering paragraph 16, D.92-11-062, the calling party's number will not be delivered or announced to the call recipient under any circumstances.

\*69 - allows a customer to automatically return the last incoming call whether it is answered or not. Upon activation of this feature, the calling number will be automatically dialed. If the called line is busy, a 30 minute queuing process begins. The customer is given an indication that the network will attempt to set up the call when the called line is idle. The network will periodically test the busy/idle status of both parties until both lines are found idle, the customer cancels the request, or the queuing process expires. If both lines are found to be idle, the customer is alerted with a distinctive ring signifying that the call can now be completed.

Calls initiated by \*69 will appear on the subscriber's billing record by area code and prefix only. The calling party's number will not be announced to the \*69 customer.

The pay per use charge is activated irrespective of whether the call is completed or not. Pay per use customers will be charged upon dialing the activation code without any specific prior request for the feature.

<sup>1</sup> Priority Call and Business Call Block services are grandfathered and limited to existing customers at existing locations as of March 21, 2005. No moves, additions or changes may be made to existing service.

Effective: April 1, 2016

---

BUNDLED/ PACKAGED SERVICES

CUSTOM CALL PLUS FEATURE PACKAGE (Continued)

I. SPECIAL CONDITIONS (Continued)

B. Feature Description (Continued)

Call Trace - automatically initiates a trace of the last incoming calling number when activated by a customer. Information from the traced call is maintained in the company security department's secured database. The customer requesting the Call Trace will not receive the traced calling number from the Company. The call trace information will only be disclosed to a law enforcement agency for investigative purposes.

Call Trace is available on a monthly subscription basis, or on a pay per use basis. Pay per use customers will be charged upon dialing the activation code without any specific prior request for the feature.

- C. CCP is available to customers having exchange access line service provided from a generically equipped central office where adequate facilities are present.
- D. CCP will not be available to customers having Two-Party/Multi-Party Lines, Key Systems, Coin and Coinless pay Phones, Hotel/Motel and Hospital Lines, PBX Service, Public Access Line Service, Mobile Telephone Service, 900, 976, and 800/888 lines and data access lines. CCP features will only operate when both the caller and the call recipient are served from capable switches and with adequate end user CPE.
- E. CCP features will be offered on a subscription basic only. The customer must specify each exchange access line to be equipped with the specific CCP features desired.
- F. A CCP customer may employ all available CCP features under the following conditions:
- When both the CCP customer and the other party involved in the call are served from the same central office, even if the other party does not subscribe to CCP.
  - When both the CCP customer and the other party involved in the call are served from different central offices which are linked by facilities that can handle the delivery of the calling number, even if the other party does not subscribe to CCP.

II. RATES AND CHARGES

Custom Calling Plus Feature Packages, each line <sup>1</sup>	<u>Percent Discount</u>
Two Feature Package	25%
Three Feature Package	30%
Four or More Feature Package	35%

<sup>1</sup> Custom Calling Plus Feature Packages are available to existing business customers listed in exchanges in Section 4A, Sheet 2 of this Product Guide.

Effective: April 1, 2016

---

BUNDLED/ PACKAGED SERVICES

150 SATELLITE CHANNEL PROGRAMMING PAC

I. SPECIAL CONDITIONS

- A. This service offers a discount off the monthly rates for the following Custom Local Area Signaling Service (CLASS) features, provided the customer orders three or more features on the same business account.

The following features are eligible for the 150 Satellite Channel Programming PAC offering:

Busy Redial  
\*69  
Call Block <sup>1</sup>  
Call Forwarding (Flexible)  
Call Waiting <sup>2</sup>  
Caller ID  
Caller ID - Number Only <sup>2</sup>  
Call Waiting / Cancel Call Waiting  
Distinctive Ring  
Do Not Disturb <sup>1</sup>  
Select Call Forwarding  
Speed Dialing (8 Code Capacity)  
Speed Dialing (30 Code Capacity)  
Three Way Calling  
Priority Call <sup>1</sup>  
Bonus Feature  
Anonymous Call Block

- B. 150 Satellite Channel Programming PAC is available to business customers only.
- C. When a customer subscribes to three or more of the features as specified in (a) preceding, the discount as specified in Rates following will apply to all of these features.
- D. If the number of qualifying features ordered is less than three, or the customer removes a feature or features such that the total subscribed to become less than three, the discount does not apply.
- E. One feature may be substituted for another, or other features may be added at a later date.

<sup>1</sup> Call Block, Do Not Disturb and Priority Call are grandfathered and limited to existing customers at existing locations as of March 21, 2005. No moves, additions or changes of these features may be made to existing 150 Satellite Channel Programming PAC service.

<sup>2</sup> Call Waiting and Caller ID - Number Only are grandfathered and limited to existing customers at existing locations as of May 26, 2005. No moves, additions or changes of these features may be made to existing 150 Satellite Channel Programming PAC service.

Effective: April 1, 2016

---

BUNDLED/ PACKAGED SERVICES

150 SATELLITE CHANNEL PROGRAMMING PAC (Continued)

I. SPECIAL CONDITIONS (Continued)

- F. All features that qualify under 150 Satellite Channel Programming PAC will be discounted by the percentage indicated under Rates below.
- G. Nonrecurring Charges as set forth in Section 3, Service Charges, are not applicable to customers ordering 150 Satellite Channel Programming PAC. These charges are not applicable when one feature is substituted for another in the 150 Satellite Channel Programming PAC or when other features are added to the 150 Satellite Channel Programming PAC after the initial installation of a 150 Satellite Channel Programming PAC.
- H. Anonymous Call Block is offered as a bonus service in the 150 Satellite Channel Programming PAC. When a customer subscribes to three or more of the eligible services listed above and subscribes to Anonymous Call Block as the fourth feature, the monthly rate for Anonymous Call Block will also be discounted at a 30% discount.

II. RATES AND CHARGES

150 Satellite Channel Programming PAC <sup>1</sup>

All features that qualify under the 150 Satellite Channel Programming PAC offering (see Special Condition A. preceding) will be discounted by 30% for business customers.

<sup>1</sup> Nonrecurring Charges as found in Section 3, Service Charges, will not be applicable to 150 Satellite Channel Programming PAC customers when, (a) ordering 150 Satellite Channel Programming PAC, (b) when one feature is substituted for another in 150 Satellite Channel Programming PAC or (c) when other features are added to 150 Satellite Channel Programming PAC after the initial installation of a 150 Satellite Channel Programming PAC.

Effective: March 4, 2022

---

BUNDLED/ PACKAGED SERVICES

FTR BUSINESS PACK\*

(C)

FTR Business Basic Pack, Complete and Deluxe Packs are a combination of Custom Calling and CLASS features available at term discounts to business customers.

A. Features - Features within the packages cannot be substituted for other features.

1. Features offered in FTR Business Basic Pack consist of:

**Option A**<sup>1</sup>

Call Waiting/Cancel Call Waiting	Caller ID <sup>2</sup>
Three-Way Calling	Special Call Forwarding

**Option B**<sup>1</sup>

Call Waiting/Cancel Call Waiting	Caller ID <sup>2</sup>
Three-Way Calling	Enhanced Call Forwarding-Existing Number

2. Features offered in FTR Business Complete Pack consist of:

Call Waiting/Cancel Call Waiting	Caller ID <sup>2</sup>
Three-Way Calling	Flexible Call Forwarding

3. Features offered in FTR Business Deluxe Pack consist of:

Call Waiting/Cancel Call Waiting	Flexible Call Forwarding
Three-Way Calling	*69
Caller ID <sup>2</sup>	Distinctive Ring

B. Termination Liability

In the event the customer terminates service within the first 60 days, the customer will be liable for the applicable monthly recurring charges; however, the Termination Liability will be waived. If the customer terminates service after 60 days but prior to completion of the term commitment period, the customer shall be liable for an early termination charge. See Section 2 of this Product Guide for Termination Liability terms and conditions.

If the customer terminates a FTR Business Pack to subscribe to Unlimited Local and Toll Usage for Business with Feature Package One, Two A, or Three<sup>3</sup> on the same line, no termination liability charges will apply.

<sup>1</sup> Offered in exchanges where technically feasible.

<sup>2</sup> Includes Anonymous Call Block at no additional charge.

<sup>3</sup> See rates, terms and conditions for Unlimited Local and Toll Usage for Business and Feature Package One, Two A, and Three in this Section.

\* This service is grandfathered and limited to all existing subscribers at their existing locations as of March 4, 2022.

(N)

Effective: March 4, 2022

---

BUNDLED/ PACKAGED SERVICES

FTR BUSINESS PACK\* (Continued)

(C)

C. Rates and Charges

	<u>Monthly Rate</u>
1. Basic Pack	
<b>Option A</b> <sup>2</sup>	
1 Year Term	\$17.10
2 Year Term	15.68
3 Year Term	14.25
<b>Option B</b> <sup>2</sup>	
1 Year Term	20.10
2 Year Term	18.43
3 Year Term	16.75
2. Complete Pack	
1 Year Term	17.10
2 Year Term	15.68
3 Year Term	14.25
3. Deluxe Pack	
1 Year Term	24.30
2 Year Term	22.28
3 Year Term	20.25

<sup>1</sup> Nonrecurring Charges as found in Section 3, Service Charges, are not applicable to customers ordering an FTR Business Pack. Features within the FTR Business Pack cannot be substituted for other features.

<sup>2</sup> Offered in exchanges where technically feasible.

\* This service is grandfathered and limited to all existing subscribers at their existing locations as of March 4, 2022.

(N)

Effective: Mrch 4, 2022

---

BUNDLED/ PACKAGED SERVICES

UNLIMITED LOCAL USAGE FOR BUSINESS/UNLIMITED LOCAL AND TOLL USAGE FOR BUSINESS\*

(C)

I. SPECIAL CONDITIONS

- A. The Unlimited Local Usage for Business and Unlimited Local and Toll Usage for Business packages are optional calling plans available on a month-to-month or one-year term to business customers with Basic Exchange Access Line Business Service (B1), Centrex, or Centrex Communications System Service.

The Unlimited Local Usage for Business plan provides unlimited local voice usage for a flat monthly rate within the customer's local calling area, including Zones 1 and 2, ZUM Zone 3 usage where facilities permit.

The Unlimited Local and Toll Usage for Business plan provides unlimited local and intraLATA Toll voice usage for a flat monthly rate within the customer's local, Zones 1 and 2, ZUM Zone 3, and intraLATA areas, where facilities permit.

- B. Monthly rates or one-year term rates for either plan apply per line in addition to B1, Centrex, or Centrex Communications System monthly line rates.

Nonrecurring charges as set forth in Section 3, Service Charges, are not applicable for customers ordering either plan on an existing B1, Centrex, or Centrex Communications System line.

- C. All terms and conditions applicable to B1, Centrex, or Centrex Communications System Service apply to that service when offered with these packages.

- D. Unlimited Local Usage for Business or Unlimited Local and Toll Usage for Business is only available to business customers who subscribe to Frontier as their carrier for all local and intraLATA toll calls.

- E. These packages are available to business customers who subscribe to 25 or fewer Frontier lines (voice grade or voice grade equivalent) per customer location at the time service is initiated. Eligible business customers may subscribe to Unlimited Local Usage for Business or Unlimited Local and Toll Usage for Business for a maximum of ten (10) lines per customer location.

- F. The packages are not available with the following services:

- ISDN Basic Service
- ISDN Primary Service
- Remote Call Forwarding Service
- Auto Universal Call Distribution (ACD/UCD)
- PBX Trunks
- Foreign Exchange Service
- Customer Owned Pay Telephone (COPT)

\* This service is grandfathered and limited to all existing subscribers at their existing locations as of March 4, 2022.

(N)

Effective: Mrch 4, 2022

---

BUNDLED/ PACKAGED SERVICES

UNLIMITED LOCAL USAGE FOR BUSINESS/UNLIMITED LOCAL AND TOLL USAGE FOR BUSINESS\* (Continued)

(C)

I. SPECIAL CONDITIONS (Continued)

- G. Unlimited Local Usage for Business or Unlimited Local and Toll Usage for Business is not available in combination with the following business packages or optional plans:
- Corporate Rewards
  - Centrex Calling Solutions
- H. Unlimited Local Usage for Business or Unlimited Local and Toll Usage for Business package does not apply to the following calls or services:
- Operator Handled Station-to-Station Service
  - Operator Handled Person-to-Person Service
  - Operator Handled Credit/Calling Card Calls
  - Directory Assistance Service
  
  - 900 and 976 Service
  - 800 Service
  - Extended Area Service (EAS)
  - Three Way Calling (per activation)
  - \*69 (per activation)
- I. Unlimited Local Usage for Business or Unlimited Local and Toll Usage for Business may only be used for voice applications and incidental non-broadcast facsimile usage, and may not be used for the transmission of data, for internet connections, or for any other non-voice application. This service may also not be used for autodialing, predictive dialers, or facsimile broadcasting, blasting, or spamming. Frontier reserves the right to restrict the number of other services and/or equipment furnished or used in connection with any particular class of service in order to prevent any impairment in the quality of service furnished. If the Customer uses either of these Services for any non-eligible purpose, including, but not limited to, the examples noted above, the Company may suspend, restrict or cancel the Service according to the provisions of the General Exchange Tariff, Schedule No. D&R, Rule No. 10.
- J. Unlimited Local Usage for Business or Unlimited Local and Toll Usage for Business is available on a month-to-month or on a one-year term. Term agreements are applied per line and are not required to be co-terminus. At the end of the term period or any subsequent renewal, the agreement will automatically be renewed for successive one-year terms on the same terms and conditions, unless either party provides advance notice that it does not wish to renew the term. Each subsequent renewal will allow for a 60-day grace period for the Customer to remove the plan without penalty. Pricing will remain the same during any automatic renewal unless the Company has provided 30 days notice of any change.

\* This service is grandfathered and limited to all existing subscribers at their existing locations as of March 4, 2022.

(N)



Effective: March 4, 2022

---

BUNDLED/ PACKAGED SERVICES

UNLIMITED LOCAL USAGE FOR BUSINESS/UNLIMITED LOCAL AND TOLL USAGE FOR BUSINESS\* (Continued)

(C)

I. SPECIAL CONDITIONS (Continued)

K. In the event a Customer terminates one-year term service within the first 60 days, starting on the Order Completion Date, the Customer will be liable for the month-to-month charges up to the date of termination, and any termination liability will be waived. If the Customer terminates service after 60 calendar days, but prior to the completion of the term commitment period, the customer shall be liable for early termination charges as set forth in Section 2 of this Product Guide. Early termination charges will not be assessed under the circumstances described in part B of Section 2, IX.B. of this Product Guide.

L. A Customer may discontinue enrollment in a month-to-month package at any time upon request to the Company.

M. UNLIMITED LOCAL AND TOLL USAGE FOR BUSINESS FEATURE PACKAGES

1. Feature Package One is available for the customer with Unlimited Local and Toll Usage for Business on a Basic Exchange Access Business (B1) Line. Feature Package One includes Call Forwarding, Call Waiting/Cancel Call Waiting, and/or Three Way Calling. The customer may choose any single feature, a combination of any two of the features, or all three features offered for the same rate.
2. Feature Package Two A is available for customers with Unlimited Local and Toll Usage for Business on a Basic Exchange Access Business (B1) Line, or Centrex Communications System Basic Service Line. Feature Package Two B is available for customers with a Centrex Station Line. Feature Package Two includes Caller ID and/or Voice Messaging. The customer may choose either or both of the features offered for the same rate.
3. Feature Package Three is available for customers with Unlimited Local and Toll Usage for Business on a Basic Exchange Access Business (B1) Line, Centrex Communications System Basic Service Line, or Centrex Station Line. Feature Package Three includes Caller ID and/or One Point Voice Mail (OPVM). The customer may choose either or both of the features offered for the same rate.
4. Monthly rates for Feature Packages One, Two, or Three apply in addition to the monthly rate or term rate for Unlimited Local and Toll Usage for Business. Nonrecurring charges as set forth in Section 3, Service Charges, are not applicable when ordering Feature Packages One, Two, or Three on an existing B1, Centrex, or Centrex Communications System line with Unlimited Local and Toll Usage for Business. Minor Software Change Charge in Section 11, Centrex Service, does not apply for an order for Feature Packages Two A, Two B, or Three.

\* This service is grandfathered and limited to all existing subscribers at their existing locations as of March 4, 2022.

(N)

Effective: March 4, 2022

BUNDLED/ PACKAGED SERVICES

UNLIMITED LOCAL USAGE FOR BUSINESS/UNLIMITED LOCAL AND TOLL USAGE FOR BUSINESS\* (Continued)

(C)

II. RATES AND CHARGES

	<u>Month-to-Month</u> <u>Rate</u>	<u>One-Year Term</u> <u>Rate</u>	<u>One-Year Term</u> <u>Rate</u> <sup>4</sup>
A. Unlimited Local Usage for Business <sup>1, 2, 3</sup>			
Per Basic Exchange Access Business (B1) Line	\$43.00	\$37.00	
Per Centrex Station Line	43.00	37.00	
Per Centrex Communications System Basic Service Line	43.00	37.00	
B. Unlimited Local and Toll Usage for Business <sup>1, 2, 3</sup>			
Per Basic Exchange Access Business (B1) Line	38.00	32.00	\$34.00 <sup>4</sup>
Per Centrex Station Line	38.00	32.00	34.00 <sup>4</sup>
Per Centrex Communications System Basic Service Line	38.00	32.00	34.00 <sup>4</sup>

<sup>1</sup> Unlimited Local Usage for Business or Unlimited Local and Toll Usage for Business does not include a B1, Centrex, or Centrex Communications System line. Monthly rates or term rates for either package apply in addition to the monthly line rates associated with these services.

<sup>2</sup> For Business customers with 25 or fewer lines at time service is initiated per customer location. Eligible Business customers may subscribe to these packages for a maximum of ten (10) lines per customer location.

<sup>3</sup> Nonrecurring charges as set forth in Section 3, Service Charges, are not applicable for customers ordering either of these packages on an existing B1, Centrex, or Centrex Communications System line.

<sup>4</sup> One Year Term Option with Unlimited Nationwide Long Distance Calling Plan through Frontier Long Distance.

\* This service is grandfathered and limited to all existing subscribers at their existing locations as of March 4, 2022.

(N)

Effective: March 4, 2022

---

BUNDLED/ PACKAGED SERVICES

UNLIMITED LOCAL USAGE FOR BUSINESS/UNLIMITED LOCAL AND TOLL USAGE FOR BUSINESS\* (Continued)

(C)

II. RATES AND CHARGES (Continued)

	<u>Monthly Rate</u>
A. Unlimited Local and Toll Usage for Business Feature Packages <sup>1, 2, 3</sup>	
1. Feature Package One per Basic Exchange Access Business (B1) Line	\$19.00
2. Feature Package Two Feature Package Two A per Basic Exchange Access Business (B1) Line, or Centrex Communications System Basic Service Line	25.00
Feature Package Two B per Centrex Station Line	25.00
3. Feature Package Three per Basic Exchange Access Business (B1) Line, Centrex Communications System Basic Service Line, or Centrex Station Line	28.00

<sup>1</sup> Monthly rates for Feature Packages One, Two or Three apply in addition to the monthly rate or term rate for Unlimited Local and Toll Usage for Business.

<sup>2</sup> Nonrecurring charges as set forth in Section 3, Service Charges, are not applicable when ordering Feature Packages One, Two, or Three on existing B1, Centrex, or Centrex Communications System lines with Unlimited Local and Toll Usage for Business. Minor Software Change Charge in Section 11, Centrex Service, does not apply for an order for Feature Packages Two A, Two B, or Three.

<sup>3</sup> See Special Conditions in this Section for Feature Package descriptions and conditions.

\* This service is grandfathered and limited to all existing subscribers at their existing locations as of March 4, 2022.

(N)

Effective: April 1, 2016

---

BUNDLED/ PACKAGED SERVICES

UNLIMITED BUSINESS ACCESS (B1) LINE AND UNLIMITED COMMUNICATIONS SYSTEM PACKAGES<sup>1</sup>

I. SPECIAL CONDITIONS

Unlimited Business Access (B1) Line and Unlimited Communications System Basic Packages are optional business flat-rated usage packages with a network access line, calling features and specified non-regulated services offered for a one-year or three-year term commitment. Customers must purchase at least one (1) Expansion Line for each Basic Package. Expansion Lines are offered on a monthly basis per each additional line ordered.

The following two (2) options are available:

A. Unlimited Business Access (B1) Line Basic Package includes the following:

- One (1) Business Access (B1) Line with touch-tone
- Unlimited local calling
- Unlimited intraLATA toll calling
- Choice of any or all of the following calling features:

Call Waiting, Three-Way Calling, Call Forwarding, Caller ID and any Voice Messaging Service

An additional credit will apply if provisioned with Frontier Broadband service.

1. Unlimited Business Access (B1) Expansion Lines

At least one (1) Expansion Line is required with each Unlimited Business Access (B1) Line Package. The following two (2) options are available:

(a) Expansion Lines with unlimited calling

B1 Expansion Lines are available for a monthly rate, per line, with unlimited local and intraLATA toll usage calling and a choice of any or all of the following calling features:

Call Waiting, Three-Way Calling, Call Forwarding, Caller ID and any Voice Messaging Service

(b) Expansion Lines without unlimited calling

B1 Expansion Lines are available for a monthly rate, per line, and choice of any or all of the following calling features:

Call Waiting, Three-Way Calling, Call Forwarding, Caller ID and any Voice Messaging Service

<sup>1</sup> As of March 17, 2012, the Unlimited Business Access (B1) Line and Unlimited Communications System Packages will not be provided to new subscribers. They will be provided only to customers who subscribed to the packages as of March 16, 2012.

Effective: April 1, 2016

---

BUNDLED/ PACKAGED SERVICES

UNLIMITED BUSINESS ACCESS (B1) LINE AND UNLIMITED COMMUNICATIONS SYSTEM PACKAGES<sup>1</sup> (Continued)

I. SPECIAL CONDITIONS (Continued)

The following two (2) options are available: (Continued)

B. Unlimited Communications System Basic Package includes the following:

- One (1) Communications System Line
- Unlimited local calling
- Unlimited intraLATA toll calling
- Choice of one or both of the following calling features:

Caller ID and/or any Voice Messaging Service

An additional credit will apply if provisioned with Frontier Broadband service.

1. Unlimited Communications System Expansion Lines

At least one (1) Expansion Line is required with each Unlimited Communications System Basic Package. The following two (2) options are available:

(a) Expansion Lines with unlimited calling

Communications System Expansion Lines are available for a monthly rate, per line, with unlimited local and intraLATA toll usage calling and a choice of one or both of the following calling features:

Caller ID and/or any Voice Messaging Service

(b) Expansion Lines without unlimited calling

Communications System Expansion Lines are available for a monthly rate, per line, and choice of one or both of the following calling features:

Caller ID and/or any Voice Messaging Service

C. Conditions

1. Unlimited B1 and Communications System Basic Packages are available only on Basic Exchange Access Line Business Service and Centrex Communications System lines where facilities and conditions permit.
2. Unlimited B1 and Communications System Basic Packages are available to business customers who subscribe to 25 or fewer lines (voice grade or voice grade equivalent) per customer location at the time service is initiated.

<sup>1</sup> As of March 17, 2012, the Unlimited Business Access (B1) Line and Unlimited Communications System Packages will not be provided to new subscribers. They will be provided only to customers who subscribed to the packages as of March 16, 2012.

Effective: April 1, 2016

---

BUNDLED/ PACKAGED SERVICES

UNLIMITED BUSINESS ACCESS (B1) LINE AND UNLIMITED COMMUNICATIONS SYSTEM PACKAGES <sup>1</sup> (Continued)

I. SPECIAL CONDITIONS (Continued)

C. Conditions (Continued)

3. Unlimited B1 and Communications System Basic Packages are only available with subscription to a business unlimited nationwide long distance calling plan through Frontier Communications of America, Inc. and Frontier highspeed internet service. Each Expansion Line must also subscribe to a business long distance calling plan through Frontier Communications of America, Inc.
4. Customers must purchase at least one (1) Expansion Line with each Unlimited B1 Basic Package Package or Unlimited Communications System Basic Package. Customers are allowed up to 24 Expansion Lines per customer location. A maximum of nine (9) such lines can have Unlimited Calling either with this plan or any other unlimited local and/or toll product offered by Frontier.
5. Customers may have any combination of Expansion Lines but the combined total number of Expansion Lines allowed is 24 per customer location and may not exceed nine (9) Expansion Lines with Unlimited Calling per customer location.
6. Usage rates will apply in addition to the Monthly rate for Expansion Lines without Unlimited Calling.
7. Unlimited B1 and Communications System Basic Packages are available only on a one-year or three-year term agreement. Expansion Lines are available on a month-to-month basis only.
8. All terms and conditions applicable to B1 or Centrex Communications System Service apply to that service when offered with the Unlimited B1 and Communications System Basic Packages.
9. Unlimited B1 and Communications System Basic Packages are not available in combination with the following business packages or optional plans:
  - Corporate Rewards
  - Centrex Calling Solutions
10. Unlimited B1 and Communications System Basic Packages are not available in combination with other optional calling plans or virtual private network services.
11. Unlimited B1 and Unlimited Communications System Basic Packages are not available with services provided under a special contract.

<sup>1</sup> As of March 17, 2012, the Unlimited Business Access (B1) Line and Unlimited Communications System Packages will not be provided to new subscribers. They will be provided only to customers who subscribed to the packages as of March 16, 2012.

Effective: March 1, 2018

---

BUNDLED/ PACKAGED SERVICES

UNLIMITED BUSINESS ACCESS (B1) LINE AND UNLIMITED COMMUNICATIONS SYSTEM PACKAGES <sup>1</sup> (Continued)

I. SPECIAL CONDITIONS (Continued)

C. Conditions (Continued)

12. Unlimited B1 and Unlimited Communications System Basic Packages are not available with the following services:

- ISDN Basic Service
- ISDN Primary Service
- Remote Call Forwarding Service
- Auto Universal Call Distribution (ACD/UCD)
- PBX Trunks
- Foreign Exchange Service
- Customer Owned Pay Telephone (COPT)

13. Unlimited B1 and Unlimited Communications System Basic Packages do not apply to the following calls or services:

- Operator Handled Station-to-Station Service
- Operator Handled Person-to-Person Service
- Operator Handled Credit/Calling Card Calls
- Directory Assistance Service
  
- 900 and 976 Service
- Wide Area Telecommunications and 800 Service
- Extended Area Service (EAS)
- Three Way Calling (per activation)
- \*69 (per activation)

(D)

14. Unlimited B1 and Unlimited Communications System Basic Packages may only be used for voice applications and incidental non-broadcast facsimile usage, and may not be used for the transmission of data, for internet connections, or for any other non-voice application. This service may also not be used for autodialing, predictive dialers, or facsimile broadcasting, blasting, or spamming. Frontier reserves the right to restrict the number of other services and/or equipment furnished or used in connection with any particular class of service in order to prevent any impairment in the quality of service furnished. If the customer uses this service for any non-eligible purpose, including, but not limited to, the examples noted above, the Company may suspend, restrict or cancel the service.

15. Call details are not available for this service.

<sup>1</sup> As of March 17, 2012, the Unlimited Business Access (B1) Line and Unlimited Communications System Packages will not be provided to new subscribers. They will be provided only to customers who subscribed to the packages as of March 16, 2012.

Effective: April 1, 2016

---

BUNDLED/ PACKAGED SERVICES

UNLIMITED BUSINESS ACCESS (B1) LINE AND UNLIMITED COMMUNICATIONS SYSTEM PACKAGES<sup>1</sup> (Continued)

I. SPECIAL CONDITIONS (Continued)

D. Termination Liability

Unlimited B1 and Unlimited Communications System Basic Packages are offered on a one-year or a three-year term agreement.

Early termination of a Unlimited B1 Basic Package or Unlimited Communications System Basic Package term agreement by the customer will result in a one-time flat Termination Charge of:

<u>1-year term agreement</u>	<u>3-year term agreement</u>
\$75.00	\$225 for default within the 1st year of the term \$150 for default within the 2nd year of the term \$75 for default within the 3rd year of the term

If the customer cancels any of the unregulated components or all of the Expansion Line(s) of the bundle, the remaining components will revert to the individual rate and/or the rate elsewhere in this Product Guide that is associated with that component.

The customer can add, delete or change the Expansion Lines without termination charges as long as two (2) lines (the core, Basic Package, and one Expansion Line) remain on the account. If the one Expansion Line is removed, the remaining elements will revert to rates found elsewhere in this Product Guide. If the Basic Package core line is removed, the applicable termination charge shown above will apply.

Customer termination of service within the first 60 days, starting on the Order Completion Date, will result in customer liability for the monthly charges. Termination liability will be waived.

At the end of the term period or any subsequent renewal, the agreement will automatically be renewed for a successive one-year or three-year term at the same terms and conditions, unless either party provides advance notice that it does not wish to renew the term. Each subsequent renewal will allow for a 60-day grace period for the subscriber to unsubscribe from the plan without penalty. Pricing will remain the same during any automatic renewal unless the Company has provided 30 days notice of any change. Customers can move from a one-year to a three-year term without incurring a penalty.

E. Application of Rates and Charges

1. Service Order Activity Charges from Section 3 are waived if a class of service change is required in order to have an Unlimited B1 or Unlimited Communications System Basic Package.
2. Applicable Service Charges as specified in Section 3, Service Charges, will be waived for customers subscribing to a three-year agreement.

<sup>1</sup> As of March 17, 2012, the Unlimited Business Access (B1) Line and Unlimited Communications System Packages will not be provided to new subscribers. They will be provided only to customers who subscribed to the packages as of March 16, 2012.



Effective: April 1, 2016

---

BUNDLED/ PACKAGED SERVICES

UNLIMITED BUSINESS ACCESS (B1) LINE AND UNLIMITED COMMUNICATIONS SYSTEM PACKAGES <sup>4</sup> (Continued)

II. RATES AND CHARGES

	<u>Monthly Rate</u>	
	<u>One-Year Term</u>	<u>Three-Year Term</u>
A. Unlimited Business Access (B1) Line Basic Package <sup>1</sup>	\$ 70.00	\$55.00
	<u>Monthly Rate</u>	
1. Expansion Line with Unlimited Calling, per line <sup>2</sup>	\$36.50	
2. Expansion Line without Unlimited Calling, per line <sup>2,3</sup>	36.50	
	<u>Monthly Rate</u>	
	<u>One-Year Term</u>	<u>Three-Year Term</u>
B. Unlimited Communications System Basic Package <sup>1</sup>	\$ 65.00	\$55.00
	<u>Monthly Rate</u>	
1. Expansion Line with Unlimited Calling, per line <sup>2</sup>	\$46.50	
2. Expansion Line without Unlimited Calling, per line <sup>2,3</sup>	31.50	

<sup>1</sup> At least one (1) Expansion Line is required with each Unlimited Business Access (B1) Line Basic Package or Unlimited Communications System Basic Package ordered.

<sup>2</sup> Customers may have any combination of Expansion Lines but the combined total number allowed is 24 per customer location and may not exceed nine (9) Expansion Lines with Unlimited Calling per customer location.

<sup>3</sup> Usage rates apply in addition to the monthly rate.

<sup>4</sup> As of March 17, 2012, the Unlimited Business Access (B1) Line and Unlimited Communications System Packages will not be provided to new subscribers. They will be provided only to customers who subscribed to the packages as of March 16, 2012.

Effective: April 1, 2016

---

BUNDLED/ PACKAGED SERVICES

BASIC BUNDLE <sup>1</sup>

I. SPECIAL CONDITIONS

- A. This service offers six (6) custom calling features in a bundled service to single line residential customers only.
- B. The custom calling features offered in the Basic bundle are:
  - Call Waiting
  - Cancel Call Waiting
  - Caller ID
  - \*69
  - Three Way Calling
  - Call Block
- C. Basic Bundle is offered where the network is technically capable.
- D. Nonrecurring charges as set forth in Section 3, Service Charges, are not applicable to customers ordering Basic Bundle.
- E. Custom calling features within the Basic Bundle cannot be substituted for other custom calling features. Customers may subscribe to additional individual custom calling services at the rates in Section 6, General Services, Custom Calling Services.

II. RATES AND CHARGES

	<u>Monthly Rate</u>
Basic Bundle, per line <sup>2</sup>	\$18.95

<sup>1</sup> Effective March 7, 2014, Basic Bundle, provided for a monthly charge, is no longer available for purchase. Service is not offered for new installations, moves, changes, or additions.

<sup>2</sup> Nonrecurring charges in Section 3, Service Charges, are not applicable.

Effective: April 1, 2016

---

BUNDLED/ PACKAGED SERVICES

COMPLETE PACKAGE<sup>1</sup>

I. SPECIAL CONDITIONS

A. Complete Package offers fourteen (14) custom calling services into one service package to single line residential customers.

B. Services offered in the Complete Package are:

Call Waiting	*69
Cancel Call Waiting	Speed Dialing 30
Caller ID Anonymous	Call Block
Distinctive Ring	Busy Redial
Three Way Calling	Priority Call
Call Block	Do Not Disturb
Call Forwarding	Select Call Forwarding

C. Complete Package is offered where the network is technically capable.

D. Nonrecurring charges as set forth in Section 3, Service Charges, are not applicable to customers ordering Complete Package.

E. Custom calling features within the Complete Package cannot be substituted for other custom calling features. Customers may subscribe to additional individual custom calling services at the rates in Section 6, General Services, Custom Calling Services.

II. RATES AND CHARGES

	<u>Monthly Rate</u>
Complete Package, per line <sup>1</sup>	\$19.95

<sup>1</sup> Effective February 14, 2014, Complete Package is no longer available for purchase. Existing customers of record may retain this service at existing locations in accordance with the terms and conditions described herein. Service is not offered for new installations, moves, changes, or additions.

Effective: April 1, 2016

---

BUNDLED/ PACKAGED SERVICES

FTR CALLING FEATURE PACKAGES <sup>1,2</sup>

I. SPECIAL CONDITIONS

FTR Calling Feature Packages – 1 <sup>2</sup> and 2 <sup>1</sup>, offers a combination of Custom Calling and CLASS features available to Residential Exchange Service customers.

The predefined list of features noted in the packages cannot be substituted with other features.

A. Customers who subscribe to FTR Calling Feature Package 1 <sup>3</sup> will receive the following features:

Call Waiting	Anonymous Call Block
Cancel Call Waiting	Busy Redial
Call Forwarding-Variable	*69
Three-Way Calling	Call Block
Speed Dialing 8	Do Not Disturb
Distinctive Ring	Select Call Forwarding
Caller ID	Priority Call
Call Waiting ID (where available)	

Home Voice Mail - Standard Package may be purchased at the discounted rates specified in Rates, part a. following.

B. Customers who subscribe to FTR Calling Feature Package 2 <sup>1</sup> will receive the following features:

Call Waiting	Three-Way Calling
Cancel Call Waiting	*69
Call Forwarding-Variable	Call Block

OnePoint Voice Mail Service may be purchased with FTR Calling Feature Package 1 <sup>3</sup> or 2 <sup>2</sup> at the discounted rate specified in Rates, part A. or B. following.

C. Home Voice Mail Packaged Offerings

1. Home Voice Mail Standard - Package provides the following features:

Basic Voice Mail	Reminder Messages
Automatic Message Review	Wake Up Service

2. OnePoint Voice Mail (OPVM) Service - see Section 7 for features and special conditions for OnePoint Voice Mail Service.

<sup>1</sup> Effective February 14, 2014, FTR Calling Feature Package 2 is no longer available for purchase. Existing customers of record may retain this service at existing locations in accordance with the terms and conditions described herein. Service is not offered for new installations, moves, changes, or additions.

<sup>2</sup> Effective March 7, 2014, FTR Calling Feature Package 1 is no longer available for purchase. Service is not offered for new installations, moves, changes, or additions.

Effective: April 1, 2016

---

BUNDLED/ PACKAGED SERVICES

FTR CALLING FEATURE PACKAGES <sup>5,6</sup> (Continued)

II. RATES AND CHARGES

	<u>Monthly Rate</u>
A. FTR Calling Feature Package 1 <sup>1,6</sup>	\$22.75
Customers who subscribe to FTR Calling Feature Package 1 may purchase the following features at the specified discounted rate:	
Home Voice Mail - Standard Package <sup>2,3,4</sup>	7.00
OnePoint Voice Mail Service <sup>2,3,4</sup>	9.00
B. FTR Calling Feature Package 2 <sup>1,5</sup>	15.75
Customers who subscribe to FTR Calling Feature Package 2 may purchase the following features at the specified discounted rate:	
OnePoint Voice Mail Service <sup>2,3,4</sup>	9.00

<sup>1</sup> Nonrecurring charges from Section 3, Service Charges, are not applicable.

<sup>2</sup> Feature must be purchased in conjunction with FTR Calling Feature Package 1 <sup>9</sup> or 2 to receive a waiver of the nonrecurring charges set forth in Section 5, General Services, Home Voice Mail Services.

<sup>3</sup> For customers with Measured-Rate Service, Local Calling Rate charges from Section 4, Local Exchange Service will apply each time the Voice Mailbox is accessed, and for each call forwarded to the Mailbox.

<sup>4</sup> Long distance charges may apply when a customer accesses the Voice Mailbox from a location outside the local calling area.

<sup>5</sup> Effective February 14, 2014, FTR Calling Feature Package 2 is no longer available for purchase. Existing customers of record may retain this service at existing locations in accordance with the terms and conditions described herein. Service is not offered for new installations, moves, changes, or additions.

<sup>6</sup> Effective March 7, 2014, FTR Calling Feature Package 1 is no longer available for purchase. Service is not offered for new installations, moves, changes, or additions.

Effective: July 7, 2016

---

BUNDLED/ PACKAGED SERVICES

FRONTIER LOCAL PACKAGE / LOCAL AND TOLL PACKAGE <sup>1</sup>/ FRONTIER LOCAL PACKAGE EXTRA/ FTR REGIONAL PACKAGE UNLIMITED/ FTR REGIONAL CALLING PLAN/ AND FRONTIER REGIONAL VALUE

I. SPECIAL CONDITIONS

Frontier Local Package / Local and Toll Package <sup>1</sup>/Frontier Local Package Extra/ FTR Regional Package Unlimited/ FTR Regional Calling Plan and Frontier Regional Value provide customers with a combination of Basic Exchange Flat-Rate Service, a choice of Custom Calling and CLASS features, and unlimited ZUM calling.

Frontier Regional Value provides Basic Exchange Flat-Rate Service and unlimited ZUM calling with no custom calling services. The Regional Packages all include unlimited IntraLATA Toll calling.

The nonrecurring service order activity, central office activity, and subsequent order charges, including the Transfer of Service charge, as specified in Section 3, Service Charges are not applicable to customers subscribing to Frontier Local Package / Local and Toll Package <sup>1</sup>/ Frontier Local Package Extra/ Regional Package Unlimited/ FTR Regional Calling Plan/ or Frontier Regional Value.

Frontier Local Package / Local and Toll Package <sup>1</sup>/ Frontier Local Package Extra/ FTR Regional Package Unlimited/ FTR Regional Calling Plan/ and Frontier Regional Value are not offered in conjunction with:

- any other package or bundled offering on the same line
- measured line service
- employee concession service
- business classes of service

Additionally, the Regional Packages are not offered in conjunction with:

- optional toll calling plans
- Integrated Services Digital Network (ISDN) service

The predefined list of features noted in the packages cannot be substituted with other features.

Frontier Local Package / Local and Toll Package <sup>1</sup>/ Frontier Local Package Extra/ FTR Regional Package Unlimited/ FTR Regional Calling Plan/ and Frontier Regional Value are provided to California Lifeline Telephone Program eligible subscribers at a discount equal to the difference between the Residential Basic Exchange Access Line rates shown in the General Exchange Tariff, Schedule A-1 and the California Lifeline Telephone Program Access Line rate as shown in Schedule A-8. California Lifeline Telephone Program eligible subscribers also receive an allowance equal to the federally mandated primary End User Common Line (EUCL) charge. Subscribers must meet the qualifications for California Lifeline Telephone Program as described in the General Exchange Tariff, Schedule No. A-8 to receive the California Lifeline Telephone Program discount and EUCL allowance. (T)

In addition to the discount provided to California Lifeline Telephone Program customers, Native American Lifeline (NALL) customers will receive an additional discount on their Residential Basic Exchange Access Line rate as shown in the General Exchange Tariff, Schedule No. A-8. (T)

<sup>1</sup> Frontier Local and Toll Package is grandfathered and limited to existing customers at existing locations as of March 21, 2005. No moves, additions or changes will be permitted.

Effective: June 1, 2023

---

BUNDLED/ PACKAGED SERVICES

FRONTIER LOCAL PACKAGE / LOCAL AND TOLL PACKAGE <sup>1</sup>/ FRONTIER LOCAL PACKAGE EXTRA/ FTR REGIONAL PACKAGE UNLIMITED/ FTR REGIONAL CALLING PLAN/ AND FRONTIER REGIONAL VALUE (Continued)

II. FRONTIER LOCAL PACKAGE <sup>3</sup>

A. Special Conditions

Customers who subscribe to Frontier Local Package may choose up to three of the following features:

Call Waiting/Cancel Call Waiting	Flexible Call Forwarding
Three-Way Calling	Anonymous Call Block
Distinctive Ring	Call Block
Busy Redial	Do Not Disturb <sup>1</sup>
*69	Select Call Forwarding
Priority Call <sup>1</sup>	Caller ID
Speed Dialing <sup>8</sup>	Speed Dialing <sup>30</sup>

Frontier Local Package also includes unlimited Zone Usage Measurement (ZUM) service at no additional charge. Home Voice Mail may be purchased at the rates specified in Section 6, General Service, Home Voice Mail Services. Customers are also eligible to subscribe to 5 Cents Plan (Plan M) as set forth in Section 16, Frontier Calling Plans.

B. Rates and Charges

	<u>Monthly Rate</u>	
Frontier Local Package <sup>2</sup>	\$48.99	(I)

<sup>1</sup> Custom Calling Services Priority Call and Do Not Disturb are grandfathered and limited to existing customers at existing locations as of March 21, 2005. No moves, additions or changes will be permitted.

<sup>2</sup> Nonrecurring service order activity, central office activity, and subsequent order charges, including the Transfer of Service charge from Section 3, Service Charges, are not applicable.

<sup>3</sup> Effective November 16, 2013, Frontier Local Package is no longer available for purchase. Existing customers of record may retain this service at existing locations in accordance with the terms and conditions described herein. Service is not offered for new installations, moves, changes, or additions.

Effective: June 1, 2023

---

BUNDLED/ PACKAGED SERVICES

FRONTIER LOCAL PACKAGE / LOCAL AND TOLL PACKAGE <sup>1</sup> / FRONTIER LOCAL PACKAGE EXTRA/ FTR REGIONAL PACKAGE UNLIMITED/ FTR REGIONAL CALLING PLAN/ AND FRONTIER REGIONAL VALUE (Continued)

III. LOCAL AND TOLL PACKAGE <sup>1</sup>

A. Special Conditions

Customers who subscribe to Local and Toll Package<sup>1</sup> may choose any of the following features:

Call Waiting/Cancel Call Waiting	Caller ID
Three-Way Calling	Flexible Call Forwarding
Distinctive Ring	Anonymous Call Block
Busy Redial	Call Block
*69	Do Not Disturb
Priority Call	Select Call Forwarding
Speed Dialing 8	Home Voice Mail Standard Package
Speed Dialing 30	

Local and Toll Package <sup>1</sup> includes a direct-dialed IntraLATA regional toll allowance of 300 minutes of usage per month. Usage exceeding 300 minutes per month will be rated at \$ .05 per minute. This offering also includes unlimited Zone Usage Measurement (ZUM) service and Home Voice Mail - Standard Package at no additional charge.

B. Rates and Charges

Monthly Rate

Local and Toll Package <sup>1,4</sup>	\$63.95	(I)
---------------------------------------	---------	-----

Customers who subscribe to Local and Toll Package <sup>1</sup> will receive Home Voice Mail - Standard Package at no additional charge, and may purchase the other two following features at the specified discounted rate:

Home Voice Mail - Standard Package <sup>2,3</sup>	--
---	----

<sup>1</sup> Frontier Local and Toll Package is grandfathered and limited to existing customers at existing locations as of March 21, 2005. No moves, additions or changes will be permitted.

<sup>2</sup> For customers with Measured-Rate Service, Local Calling Rate charges from Section 4, Local Exchange Services, will apply each time the Voice Mailbox is accessed, and for each call forwarded to the Mailbox.

<sup>3</sup> Long distance charges may apply when a customer accesses the Voice Mailbox from a location outside the local calling area.

<sup>4</sup> Nonrecurring service order activity, central office activity, and subsequent order charges, including the Transfer of Service charge from Section 3, Service Charges, are not applicable.



Effective: June 1, 2023

---

BUNDLED/ PACKAGED SERVICES

FRONTIER LOCAL PACKAGE / LOCAL AND TOLL PACKAGE <sup>1</sup>/ FRONTIER LOCAL PACKAGE EXTRA/ FTR REGIONAL PACKAGE UNLIMITED/ FTR REGIONAL CALLING PLAN/ AND FRONTIER REGIONAL VALUE (Continued)

IV. FRONTIER LOCAL PACKAGE EXTRA <sup>6</sup>

A. Special Conditions

Customers who subscribe to Frontier Local Package Extra may choose four or more of the following features:

Call Waiting/Cancel Call Waiting	Flexible Call Forwarding
Three-Way Calling	Anonymous Call Block
Distinctive Ring	Call Block
Busy Redial	Do Not Disturb <sup>5</sup>
*69	Select Call Forwarding
Priority Call <sup>5</sup>	Caller ID
Speed Dialing <sup>8</sup>	Speed Dialing <sup>30</sup>

Frontier Local Package Extra also includes unlimited Zone Usage Measurement (ZUM) service at no additional charge. Home Voice Mail or OnePoint Voice Mail Service may be purchased at the discounted rates specified shown below. Customers are also eligible to subscribe to 5 Cents Plan (Plan M) as set forth in Section 16 of this Product Guide, Frontier Calling Plans.

B. Rates and Charges

	<u>Monthly Rate</u>	
Frontier Local Package Extra <sup>1</sup>	\$51.99	(l)

Customers who subscribe to Frontier Local Package Extra may purchase the following features at the specified discounted rate:

1. Home Voice Mail - Standard Package <sup>2, 3, 4</sup>	\$7.50
2. OnePoint Voice Mail Service <sup>2, 3, 4</sup>	9.00

<sup>1</sup> Nonrecurring service order activity, central office activity, and subsequent order charges, including the Transfer of Service charge from Section 3, Service Charges, are not applicable.

<sup>2</sup> Nonrecurring charges from Section 6, General Services, Home Voice Mail Services, are applicable for Home Voice Mail or OnePoint Voice Mail Service.

<sup>3</sup> For customers with Measured-Rate Service, Local Calling Rate charges from Section 4, Local Exchange Services, will apply each time the Voice Mailbox is accessed, and for each call forwarded to the Mailbox.

<sup>4</sup> Long distance charges may apply when a customer accesses the Voice Mailbox from a location outside the local calling area.

<sup>5</sup> Custom Calling Services Priority Call and Do Not Disturb are grandfathered and limited to existing customers at existing locations as of March 21, 2005. No moves, additions or changes will be permitted.

<sup>6</sup> Effective November 16, 2013, Frontier Local Package Extra is no longer available for purchase. Existing customers of record may retain this service at existing locations in accordance with the terms and conditions described herein. Service is not offered for new installations, moves, changes, or additions.

Effective: June 1, 2023

---

BUNDLED/ PACKAGED SERVICES

FRONTIER LOCAL PACKAGE / LOCAL AND TOLL PACKAGE <sup>1</sup>/ FRONTIER LOCAL PACKAGE EXTRA/ FTR REGIONAL PACKAGE UNLIMITED/ FTR REGIONAL CALLING PLAN/ AND FRONTIER REGIONAL VALUE (Continued)

V. FTR REGIONAL PACKAGE UNLIMITED<sup>2</sup>

A. Special Conditions

Customers who subscribe to FTR Regional Package Unlimited may choose up to three of the following features:

Three Way Calling	Caller ID
Call Waiting/Cancel Call Waiting	Speed Dialing 8
Speed Dialing 30	Busy Redial
Distinctive Ring	Call Forwarding
Anonymous Call Block	*69
Select Call Forwarding	

FTR Regional Package Unlimited also includes unlimited Zone Usage Measurement (ZUM) service and unlimited IntraLATA Toll Service.

- Calls included in the unlimited IntraLATA Toll feature of this package are restricted to outbound direct-dialed IntraLATA calling. Directory Assistance, operator-handled, and calling card calls are excluded from this plan.

B. Rates and Charges

	<u>Monthly Rate</u>	
FTR Regional Package Unlimited <sup>1</sup>	\$57.00	(l)

<sup>1</sup> Nonrecurring service order activity, central office activity, and subsequent order charges, including the Transfer of Service charge from Section 3, Service Charges, are not applicable.

<sup>2</sup> Effective November 16, 2013, FTR Regional Package Unlimited is no longer available for purchase. Existing customers of record may retain this service at existing locations in accordance with the terms and conditions described herein. Service is not offered for new installations, moves, changes, or additions.

Effective: June 1, 2023

---

BUNDLED/ PACKAGED SERVICES

FRONTIER LOCAL PACKAGE / LOCAL AND TOLL PACKAGE <sup>1</sup>/ FRONTIER LOCAL PACKAGE EXTRA/ FTR REGIONAL PACKAGE UNLIMITED/ FTR REGIONAL CALLING PLAN/ AND FRONTIER REGIONAL VALUE (Continued)

VI. FTR REGIONAL CALLING PLAN

A. Special Conditions

FTR Regional Calling Plan is an optional residential service package that provides customers with a combination of Basic Exchange Flat-Rate Service, Caller ID and Call Waiting/Cancel Call Waiting, a choice of Home Voice Mail or OnePoint Voice Mail Service, unlimited ZUM calling, and unlimited IntraLATA Toll calling for one flat monthly rate per line.

Calls included in the unlimited IntraLATA Toll feature of this package are restricted to outbound direct-dialed IntraLATA calling. Directory Assistance, operator-handled, and calling card calls are excluded from these plans.

Periodically, the Company may offer various "save incentives" in the event of a competitive threat. Such incentives may be limited to specific markets, specific dates, specific products or specific pricing plans or customers who have received offers from competing services providers. Term requirements and termination liabilities may be a condition of the Save Incentive offer.

B. Rates and Charges

	<u>Monthly Rate</u>	
FTR Regional Calling Plan <sup>1</sup>	\$ 54.04 <sup>4</sup>	(I)

Includes Caller ID and Call Waiting/Cancel Call Waiting, plus a choice of one of the following Home Voice Mail packages at no additional charge:

Home Voice Mail - Standard Package <sup>2,3</sup>  
OnePoint Voice Mail Service <sup>2,3</sup>

<sup>1</sup> Nonrecurring service order activity, central office activity, and subsequent order charges, including the Transfer of Service charge from Section 3, Service Charges, are not applicable.  
<sup>2</sup> Nonrecurring charges from Section 6, General Services, Home Voice Mail Services, are not applicable for Home Voice Mail Service or OnePoint Voice Mail Service. .  
<sup>3</sup> Long distance charges may apply when a customer accesses the Voice Mailbox from a location outside the local calling area.  
<sup>4</sup> Effective March 21, 2015 to be implemented on a full bill period basis.

---

BUNDLED/ PACKAGED SERVICES

FRONTIER LOCAL PACKAGE / LOCAL AND TOLL PACKAGE <sup>1</sup>/ FRONTIER LOCAL PACKAGE EXTRA/ FTR REGIONAL PACKAGE UNLIMITED/ FTR REGIONAL CALLING PLAN/ AND FRONTIER REGIONAL VALUE<sup>3</sup> (Continued)

VII. FRONTIER REGIONAL VALUE

A. Special Conditions

Frontier Regional Value is an optional residential service package that provides customers with a combination of Basic Exchange Flat-Rate Service, unlimited ZUM calling, and unlimited IntraLATA Toll calling for one flat monthly rate per line.

Calls included in the unlimited IntraLATA Toll feature of this package are restricted to outbound direct-dialed IntraLATA calling. Directory Assistance, operator-handled, and calling card calls are excluded from these plans.

Periodically, the Company may offer various "save incentives" in the event of a competitive threat. Such incentives may be limited to specific markets, specific dates, specific products or specific pricing plans or customers who have received offers from competing services providers. Term requirements and termination liabilities may be a condition of the Save Incentive offer.

B. Rates and Charges

	<u>Monthly Rate</u>	
Frontier Regional Value <sup>1</sup>	\$52.04 <sup>2</sup>	(l)

<sup>1</sup> Nonrecurring service order activity, central office activity, and subsequent order charges, including the Transfer of Service charge from Section 3, Service Charges, are not applicable.

<sup>2</sup> Effective March 21, 2015 to be implemented on a full bill period basis.

<sup>3</sup> Frontier Regional Value is grandfathered and limited to all existing subscribers at their existing locations.

Effective: April 1, 2016

---

BUNDLED/ PACKAGED SERVICES

FTR REGIONAL ESSENTIALS DISCOUNT <sup>1</sup>

I. SPECIAL CONDITIONS

FTR Regional Essentials Discount may apply when FTR Regional Calling Plan is bundled with an unlimited domestic long distance calling plan plus one of the Frontier affiliate products listed below.

Qualifying unlimited domestic long distance calling plans must be consistent with the Plan O Service - Unlimited, as found in the Frontier Communications of America, Inc. Long Distance Service Catalog.

Frontier Broadband Up to 3.1 Mbps or up to 7.1 Mbps package refers to a specific Frontier offering that offers a maximum speed of 3.1 Mbps or 7.1 Mbps, and does not refer to other products that offer lower maximum speeds.

Beginning April 18, 2009, customers will continue receiving their existing discount on a month-to-month basis following the initial 12-month term of their offer. Customers whose initial 12-month term expired prior to April 18, 2009 will receive the monthly discount listed in II. Rates and Charges A.2. below.

Customers are limited to one discount only and cannot combine discounts. Each product must be purchased through or billed by Frontier.

II. RATES AND CHARGES

A. For customers who were subscribed to the FTR Regional Essentials Discount as of April 30, 2008:

	<u>Monthly Discounts</u>
1. High Speed Internet (Up to 3.1 Mbps or up to 7.1 Mbps package)	\$15.00 <sup>2</sup>
2. For customers who automatically continued the FTR Regional Essentials Discount past the expiration date of their 12-month term, when the expiration date of their 12-month term was April 17, 2009 or earlier. (See Special Conditions preceding):	

	<u>Monthly Discounts</u>
High Speed Internet (Up to 3.1 Mbps or up to 7.1 Mbps package)	\$15.00 <sup>2</sup>

3. For customers who subscribed to the FTR Regional Essentials Discount on or after May 1, 2008:

	<u>Monthly Discounts</u>
High Speed Internet (Up to 3.1 Mbps or up to 7.1 Mbps package)	\$ 15.00 <sup>2</sup>

<sup>1</sup> As of November 1, 2008, the FTR Regional Essentials Discount will no longer be offered for purchase, but will remain valid for existing customers through the end of their 12-month term.

<sup>2</sup> Effective March 21, 2015 to be implemented on a full bill period basis.

Effective: May 16, 2018

---

BUNDLED/ PACKAGED SERVICES

FTR REGIONAL ESSENTIALS DISCOUNT I

I. SPECIAL CONDITIONS

FTR Regional Essentials Discount I offers qualifying residential customers a monthly discount on FTR Regional Calling Plan, subject to the limitations described in this section. The customer must agree to subscribe to FTR Regional Calling Plan and to Frontier Online High Speed Internet Service. Pricing for the FTR Regional Essentials Discount I is set forth below and depends upon which of the additional services the customer agrees to purchase, whether the customer additionally agrees to subscribe to a qualifying unlimited long distance calling plan, as described below, and, in some cases, whether the order is placed through the Frontier website.

Qualifying unlimited long distance calling plans must be consistent with the Plan O Service – Unlimited as found in the Frontier Communications of America, Inc. Long Distance Posted Rates, Terms and Conditions.

Each product must be billed by Frontier.

Customers who subscribe to FTR Regional Calling Plan and Frontier Online High Speed Internet Service will not automatically be eligible for this offering. Instead the FTR Regional Essentials Discount I will be provided to otherwise qualifying customers only upon customer request or upon customer acceptance of a suggestion, recommendation, or offer of the discount made by a Frontier representative.

The FTR Regional Essentials Discount I discount, as specified in the RATES section below, will apply from the date it is implemented on a customer's account. If the customer removes any of the products that entitle the customer to the discount, the customer will lose the discount for FTR Regional Calling Plan, but no termination liability will apply.

Periodically, the Company may offer various "save incentives" in the event of a competitive threat. Such incentives may be limited to specific markets, specific dates, specific products or specific pricing plans or customers who have received offers from competing services providers. Term requirements and termination liabilities may be a condition of the Save Incentive offer.

(N)  
|  
(N)

II. RATES AND CHARGES

	<u>Monthly Discounts</u>
FTR Regional Calling Plan without an unlimited long distance calling plan, plus:	
- Frontier Online High Speed Internet Service	\$29.05 <sup>1</sup>
- Additional discount for 24 months for orders placed through Frontier website	5.00
FTR Regional Calling Plan with a qualifying unlimited long distance calling plan, plus:	
- Frontier Online High Speed Internet Service	27.02 <sup>1</sup>

<sup>1</sup> Effective March 21, 2015 to be implemented on a full bill period basis.

Effective: January 19, 2021

---

BUNDLED/ PACKAGED SERVICES

FRONTIER® FIBEROPTIC INTERNET BUNDLE DISCOUNT<sup>1</sup> (C)

A. SPECIAL CONDITIONS

Frontier® FiberOptic Internet Bundle Discount<sup>2</sup> may apply when FTR Regional Calling Plan is bundled with an unlimited long distance calling plan plus one of the Frontier® FiberOptic Internet products on a 6, 12 or 24 month commitment as listed in Rates following. (C)

Qualifying unlimited long distance calling plans must be consistent with the Plan O Service - Unlimited rates, terms, and conditions, as found in the Frontier Communications of America, Inc. Long Distance Service Catalog.

At the expiration of a customer's first twelve-month term under the Frontier® FiberOptic Internet Internet Bundle Discount, the customer will automatically receive the discounts described under (b) in the Rates following, on a month-to-month basis. Customers with a twenty-four-month term will continue to receive their existing discount on a month-to-month basis following expiration of their initial twenty-four-month term. 12 Month Term customers with initial terms ending on or after 9/1/09 will receive renewal discounts on a month-to-month basis equal to their original initial term discount. (C)

Customers may instead elect to take month-to-month rates or, if qualified, enroll in another Frontier® FiberOptic Internet Bundle Discount term commitment. In such case, the customer must contact Frontier to arrange for the month-to-month rates or to enroll in the new term commitment. (C)

Discontinuance of any one of the bundled services will result in immediate termination of the discount. Supersedure of service<sup>3</sup> with Frontier® FiberOptic Internet Bundle Discount will not be permitted. (C)

Customers are limited to one discount only and cannot combine discounts. To qualify for the discounts, each product must be billed by Frontier or purchased through a Home Owner's Association or Property Manager under contract with Frontier Enhanced Communities, and none of the products may be billed to a credit card.

<sup>1</sup> As of January 17, 2010, the Frontier® FiberOptic Internet Bundle Discount will not be provided to new subscribers. It will be provided only to customers who subscribed to the plan as of January 16, 2010. (C)

<sup>2</sup> As of October 4, 2008, the 24-month term option will no longer be offered for purchase, but will remain valid for existing customers.

<sup>3</sup> See the General Exchange Tariff, Schedule No. D&R, Rule 8.B.

Effective: January 19, 2021

BUNDLED/ PACKAGED SERVICES

FRONTIER® FIBEROPTIC INTERNET BUNDLE DISCOUNT <sup>1,2</sup> (Continued) (C)

II. RATES AND CHARGES

Frontier® FiberOptic Internet Bundle Discount may apply when FTR Regional Calling Plan is bundled with an unlimited long distance calling plan plus one of the following Frontier® FiberOptic Internet products on a 6, 12- or 24-month commitment <sup>3</sup>: (C)

A. For customers already subscribed to the Frontier® FiberOptic Internet Bundle Discount as of February 16, 2008: (C)

	Monthly Discounts		
	<u>12 Months</u>	<u>24 Months</u>	
1. Frontier® FiberOptic Internet	\$17.01 <sup>4</sup>	\$22.01 <sup>4</sup>	(C)
2. Frontier® FiberOptic Internet TV	20.01 <sup>4</sup>	25.01 <sup>4</sup>	(C)
3. Frontier® FiberOptic Internet <i>and</i> Frontier® FiberOptic Internet TV	25.00 <sup>4</sup>	25.00 <sup>4</sup>	(C)

B. For customers who automatically continued the Frontier® FiberOptic Internet Bundle Discount past the expiration date of their twelve-Month term commitment (See Special Conditions preceding): (C)

	Monthly Discounts		
	<u>12 Months</u>		
1. Frontier® FiberOptic Internet	\$17.01 <sup>4</sup>		(C)
2. Frontier® FiberOptic Internet TV	16.01 <sup>4</sup>		(C)
3. Frontier® FiberOptic Internet and Frontier® FiberOptic Internet TV	20.00 <sup>4</sup>		(C)

C. For customers who subscribed to the Frontier® FiberOptic Internet Bundle Discount between February 17, 2008 and June 20, 2009: (C)

	Monthly Discounts		
	<u>12 Months</u>	<u>24 Months</u>	
1. Frontier® FiberOptic Internet	\$25.01 <sup>4</sup>	\$20.01 <sup>4</sup>	(C)
2. Frontier® FiberOptic InternetTV	25.01 <sup>4</sup>	25.01 <sup>4</sup>	(C)
3. Frontier® FiberOptic Internet <i>and</i> Frontier® FiberOptic Internet TV	25.00 <sup>4</sup>	25.00 <sup>4</sup>	(C)

D. For customers who subscribed to the Frontier® FiberOptic Internet Bundle Discount on or after June 21, 2009: (C)

	Monthly Discounts		
	<u>6 or 12 Month Term</u>		
1. Frontier® FiberOptic Internet	\$17.01 <sup>4</sup>		(C)
2. Frontier® FiberOptic Internet TV	20.01 <sup>4</sup>		(C)
3. Frontier® FiberOptic Internet and Frontier® FiberOptic Internet TV	25.00 <sup>4</sup>		(C)

<sup>1</sup> Section 3 nonrecurring service order activity, central office activity, and subsequent order charges, including the Transfer of Service charge, are not applicable.

<sup>2</sup> As of January 17, 2012, the Frontier® FiberOptic Internet Bundle Discount will not be provided to new subscribers. It will be provided only to customers who subscribed to the plan as of January 16, 2010. (C)

<sup>3</sup> As of October 4, 2008, the 24-month term option will no longer be offered for purchase, but will remain valid for existing customers.

<sup>4</sup> Effective March 21, 2015 to be implemented on a full bill period basis.



Effective: January 19, 2021

BUNDLED/ PACKAGED SERVICES

FRONTIER® FIBEROPTIC INTERNET BUNDLE DISCOUNT I (C)

I. SPECIAL CONDITIONS

Frontier® FiberOptic Internet Bundle Discount II may apply when FTR Regional Calling Plan is bundled with an unlimited long distance calling plan plus one or more of the Frontier® FiberOptic Internet products on a month-to-month basis or for a 24 month commitment period as listed in Rates following. Section 3 nonrecurring service order activity, central office activity, and subsequent order charges, including the Transfer of Service charge, are not applicable. (C)

Qualifying unlimited long distance calling plans must be consistent with the Plan O Service - Unlimited rates, terms, and conditions, as found in the Frontier Communications of America, Inc. Long Distance Service Catalog. (C)

Discontinuance of any one of the bundled services will result in immediate termination of the discount.

Customers are limited to one discount only and cannot combine discounts. To qualify for the discounts, each product must be billed by Frontier.

II. RATES AND CHARGES

Frontier® FiberOptic Internet Bundle Discount II may apply when FTR Regional Calling Plan is bundled with an unlimited long distance calling plan plus one or more of the following Frontier® FiberOptic Internet products on a month-to-month basis or for a 24-month commitment period: (C)

	Monthly Discounts		
	<u>Month-to-Month</u>	<u>24 Months</u>	
A. Frontier® FiberOptic Internet Bundle Discount II discounts for customers who subscribed before June 4, 2011. (C)			
Frontier® FiberOptic Internet, Frontier® FiberOptic Internet TV, or both	\$22.00 <sup>1</sup>	\$27.00 <sup>1</sup>	(C)
B. Frontier® FiberOptic Internet Bundle Discount II discounts for customers who subscribed on or after June 4, 2011 through January 17, 2014. (C)			
Frontier® FiberOptic Internet, Frontier® FiberOptic Internet TV, or both	27.00 <sup>1</sup>	27.00 <sup>1</sup>	(C)
C. Frontier® FiberOptic Internet Bundle Discount II discounts for customers who subscribed on or after January 18, 2014. (C)			
Frontier® FiberOptic Internet or Frontier® FiberOptic Internet TV	17.00 <sup>1</sup>	17.00 <sup>1</sup>	(C)
Frontier® FiberOptic Internet and Frontier® FiberOptic Internet TV	27.00 <sup>1</sup>	27.00 <sup>1</sup>	(C)

<sup>1</sup> Effective March 21, 2015 to be implemented on a full bill period basis.

Effective: April 1, 2016

---

BUNDLED/ PACKAGED SERVICES

HOME VOICE MAIL PACKAGED OFFERINGS

I. SPECIAL CONDITIONS

- A. Home Voice Mail - Standard Package is available at the discounted rates specified in IV.B. preceding of this Section when purchased in conjunction with Frontier Local Package Extra and is included in Local and Toll Package <sup>1</sup> at no additional charge. Home Voice Mail - Standard Package provides the following features:

Automatic Message Review  
Reminder Messages  
Wake Up Service

- B. OnePoint Voice Mail (OPVM) Service is available at the discounted rate specified in IV.B. preceding of this Section when purchased in conjunction with Frontier Local Package Extra. See Section 6 of this Product Guide for features and special conditions for OnePoint Voice Mail Service.
- C. A choice of Home Voice Mail or OnePoint Voice Mail Service is available at no additional charge to customers who subscribe to FTR Regional Calling Plan.

<sup>1</sup> Frontier Local and Toll Package is grandfathered and limited to existing customers at existing locations as of March 21, 2005. No moves, additions or changes will be permitted.

Effective: July 7, 2016

---

BUNDLED/ PACKAGED SERVICES

FRONTIER LOCAL PACKAGE BASIC/ FRONTIER LOCAL PACKAGE PRIME <sup>1</sup>

I. SPECIAL CONDITIONS

Frontier Local Package Basic / Frontier Local Package Prime offer a combination of Basic Exchange Flat-Rate Service, Custom Calling and CLASS features available to Residential Exchange Service customers.

The nonrecurring service order activity, central office activity, and subsequent order charges, including the Transfer of Service charge, as specified in Section 3, Service Charges, are not applicable to customers subscribing to Frontier Local Package Basic or Frontier Local Package Prime.

Frontier Local Package Basic / Frontier Local Package Prime are not offered in conjunction with:

- any other package or bundled offering on the same line
- measured line service
- employee concession service
- optional toll calling plans

The predefined list of features noted in the packages cannot be substituted with other features.

Frontier Local Package Basic and Frontier Local Package Prime are provided to California Lifeline Telephone Program eligible subscribers at a discount equal to the difference between the Residential Basic Exchange Access Line rates shown in the General Exchange Tariff, Schedule A-1, and the California Lifeline Telephone Program Access Line rate as shown in Schedule A-8. California Lifeline Telephone Program eligible subscribers also receive an allowance equal to the federally mandated primary End User Common Line (EUCL) charge. Subscribers must meet the qualifications for California Lifeline Telephone Program as described in the General Exchange Tariff, Schedule No. A-8 to receive the California Lifeline Telephone Program discount and EUCL allowance. (T)

In addition to the discount provided to California Lifeline Telephone Program customers, Native American Lifeline (NALL) customers will receive an additional discount on their Residential Basic Exchange Access Line rate as shown in the General Exchange Tariff, Schedule No. A-8. (T)

<sup>1</sup> Effective November 16, 2013, Frontier Local Package Basic/Frontier Local Package Prime are no longer available for purchase. Existing customers of record may retain this service at existing locations in accordance with the terms and conditions described herein. Service is not offered for new installations, moves, changes, or additions.

Effective: June 1, 2023

---

BUNDLED/ PACKAGED SERVICES

FRONTIER LOCAL PACKAGE BASIC/ FRONTIER LOCAL PACKAGE PRIME <sup>5</sup> (Continued)

I. FRONTIER LOCAL PACKAGE BASIC <sup>5</sup>

A. SPECIAL CONDITIONS

Customers who subscribe to Frontier Local Package Basic may choose any or all of the following features:

Call Waiting/Cancel Call Waiting	Speed Dialing 8
Three-Way Calling	Caller ID
Speed Dialing 30	

Frontier Local Package Basic also includes unlimited Zone Usage Measurement (ZUM) service and a choice of one of the following Home Voice Mail packages at no additional charge:

1. Home Voice Mail - Standard Package <sup>1, 2, 3</sup>
2. OnePoint Voice Mail Service <sup>1, 2, 3</sup>

Customers are also eligible to subscribe to 5 Cents Plan (Plan M) as set forth in Section 19, Frontier Calling Plans.

B. RATES AND CHARGES

	<u>Monthly Rate</u>	
Frontier Local Package Basic <sup>4</sup>	\$51.95	(I)

- <sup>1</sup> Nonrecurring charges from Section 6, Home Voice Mail Services, are not applicable for Home Voice Mail or OnePoint Voice Mail Service.
- <sup>2</sup> For customers with Measured-Rate Service, Local Calling Rate charges from Section 4, Local Exchange Service, will apply each time the Voice Mailbox is accessed, and for each call forwarded to the Mailbox.
- <sup>3</sup> Long distance charges may apply when a customer accesses the Voice Mailbox from a location outside the local calling area.
- <sup>4</sup> Nonrecurring service order activity, central office activity, and subsequent order charges, including the Transfer of Service charge from Section 3, Service Charges, are not applicable.
- <sup>5</sup> Effective November 16, 2013, Frontier Local Package Basic/Frontier Local Package Prime are no longer available for purchase. Existing customers of record may retain this service at existing locations in accordance with the terms and conditions described herein. Service is not offered for new installations, moves, changes, or additions.

Effective: June 1, 2023

---

BUNDLED/ PACKAGED SERVICES

FRONTIER LOCAL PACKAGE BASIC/ FRONTIER LOCAL PACKAGE PRIME <sup>5</sup> (Continued)

II. FRONTIER LOCAL PACKAGE PRIME <sup>5</sup>

A. SPECIAL CONDITIONS

Customers who subscribe to Frontier Local Package Prime may choose any or all of the following features:

Call Waiting/Cancel Call Waiting	Anonymous Call Block
Three-Way Calling	Call Block
Distinctive Ring	Flexible Call Forwarding
Busy Redial	Select Call Forwarding
*69	Caller ID
Speed Dialing 8	
Speed Dialing 30	

Frontier Local Package Prime also includes unlimited Zone Usage Measurement (ZUM) service and a choice of one of the following Home Voice Mail packages at no additional charge:

1. Home Voice Mail - Standard Package <sup>1, 2, 3</sup>
2. OnePoint Voice Mail Service <sup>1, 2, 3</sup>

Customers are also eligible to subscribe to 5 Cents Plan (Plan M) as set forth in Section 19, Frontier Calling Plans.

B. RATES AND CHARGES

	<u>Monthly Rate</u>	
	<u>Residential</u>	
Frontier Local Package Prime <sup>4</sup>	\$ 56.95	(I)

- <sup>1</sup> Nonrecurring charges from Section 6, Home Voice Mail Services, are not applicable for Home Voice Mail or OnePoint Voice Mail Service.
- <sup>2</sup> For customers with Measured-Rate Service, Local Calling Rate charges from Section 4, Local Exchange Service, will apply each time the Voice Mailbox is accessed, and for each call forwarded to the Mailbox.
- <sup>3</sup> Long distance charges may apply when a customer accesses the Voice Mailbox from a location outside the local calling area.
- <sup>4</sup> Nonrecurring service order activity, central office activity, and subsequent order charges, including the Transfer of Service charge from Section 3, Service Charges, are not applicable.
- <sup>5</sup> Effective November 16, 2013, Frontier Local Package Basic/Frontier Local Package Prime are no longer available for purchase. Existing customers of record may retain this service at existing locations in accordance with the terms and conditions described herein. Service is not offered for new installations, moves, changes, or additions.

Effective: November 10, 2020

BUNDLED/ PACKAGED SERVICES

FTR REGIONAL CALLING PLAN/ FTR REGIONAL SELECT DISCOUNT <sup>1</sup>

I. SPECIAL CONDITIONS

Customers will continue receiving their existing discount on a month-to-month basis following the initial 12-month term of their offer. Customers are limited to one discount only and cannot combine discounts. Each product must be billed by Frontier under the same billing name and address.

Qualifying unlimited long distance calling plans must be consistent with the Plan O Service -Unlimited rates, terms, and conditions, as found in the Frontier Communications of America, Inc. Long Distance Service Catalog.

II. RATES AND CHARGES

- A. FTR Regional Calling Plan or Frontier Regional Value<sup>3</sup> customers who subscribe to an unlimited long distance calling plan are eligible for a twelve-month discount when they also subscribe to one of the following services as specified by Frontier: (C)

<u>Monthly Discounts</u> <u>FTR Regional Calling Plan</u>	<u>Monthly Discounts</u> <u>Frontier Regional Value<sup>3</sup></u>			
	Subscribed prior to 1/17/2010	Subscribed on or after 1/17/2010	Subscribed prior to 1/17/2010	Subscribed on or after 1/17/2010
High Speed Internet	\$17.00 <sup>2</sup>	\$22.00 <sup>2</sup>	\$20.00 <sup>2</sup>	\$25.00 <sup>2</sup>

- B. Frontier Regional Value<sup>3</sup> customers without an unlimited long distance calling plan are eligible for a twelve-month discount when they also subscribe to one of the following services as specified by Frontier:

<u>Monthly Discounts</u> <u>Frontier Regional Value<sup>3</sup></u>
High Speed Internet
\$27.04 <sup>2</sup>

<sup>1</sup> This will no longer be available to new customers effective April 17, 2011.

<sup>2</sup> Effective March 21, 2015 to be implemented on a full bill period basis.

<sup>3</sup> Frontier Revional Value is grandfathered and limited to all existing subscribers at their existing locations.

(C)

Effective: January 19, 2021

---

BUNDLED/ PACKAGED SERVICES

SINGLE LINE BUSINESS PAK<sup>1</sup>

I. GENERAL

Single Line Business Pak is an optional business flat-rated usage packages with a network access line, calling features and specified non-regulated services offered for a one-year or three-year term commitment:

Single Line Business PAK includes the following:

- One (1) Dial Tone Line with touch-tone
- Unlimited local voice usage
- Unlimited intraLATA direct distance dialed unassisted toll calling
- Choice of zero to five (0 - 5) of the following calling features: Call Waiting, Three-Way Calling, Call Forwarding, Caller ID and a specified non-regulated service.

Note: Additional credit will apply if provisioned with Frontier Broadband Service (Frontier High-Speed Internet service or Frontier® FiberOptic Internet service.) (C)

II. REGULATIONS

A. Single Line Business Pak is available only where facilities and conditions permit.

1. Single Line Business Pak is available only to customers who subscribe to the company for their local usage and intraLATA toll calls
2. Single Line Business Pak is available only on a one-year or three-year term agreement.
3. Single Line Business Pak is only available with subscription to a business unlimited nationwide long distance calling plan through Frontier Communications of America, Inc. and Frontier High-Speed Internet service or Frontier® FiberOptic Internet service. (C)
4. Single Line Business Pak is available to business customers who subscribe to 25 or fewer lines (voice grade or voice grade equivalent) at the time service is initiated.
5. Customers may only have one Single Line Business Pak per account. A maximum of ten lines can have Unlimited Calling either with this plan or any other Unlimited Local or Local and Toll Usage Product offered by Frontier. Customers may not combine this package with the Unlimited Dialtone and Communications System Packages.

<sup>1</sup> As of March 17, 2012, the Single Line Business Pak will not be provided to new subscribers. It will be provided only to customers who subscribed to the package as of March 16, 2012.

Effective: April 1, 2016

---

BUNDLED/ PACKAGED SERVICES

SINGLE LINE BUSINESS PAK <sup>1</sup> (Continued)

II. REGULATIONS (Continued)

A. Single Line Business Pak is available only where facilities and conditions permit.

6. Single Line Business Pak is not available with the following services:

- Centrex or Communications System
- ISDN Service
- Remote Call Forwarding Service
- Auto Universal Call Distribution (ACD/UCD)
- PBX Trunks
- Digital Hand Off
- Digital PBX Service
- Foreign Exchange Service
- Foreign Central Office Service
- Customer Owned Pay Telephone (COPT)
- Ground Start Lines or Trunks
- Business Optional Calling Plan
- Business Special Toll Plan
- Corporate Rewards
- Business Calling Plus
- Business Local Usage Packages with allowances for Centrex and Business service
- Customer Specific Pricing (CSP)
- Grandfathered Rewarding Connections
- Maximum Value Plan (MVP)
- Foreign Zone Service
- Easy Savings Flat Rate Plan for Business
- Pay Telephone Lines

<sup>1</sup> As of March 17, 2012, the Single Line Business Pak will not be provided to new subscribers. It will be provided only to customers who subscribed to the package as of March 16, 2012.



Effective: March 1, 2018

---

BUNDLED/ PACKAGED SERVICES

SINGLE LINE BUSINESS PAK <sup>1</sup> (Continued)

II. REGULATIONS (Continued)

7. Single Line Business Pak is not available in combination with other optional calling plans or virtual private network services.
8. Single Line Business Pak does not apply to the following calls or services:
  - Collect Calls - Easy Number Service (D)
  - Time, Lottery and Weather
  - 555,700, 900, 976 Service
  - IDS Type Calls (Audiotext)
  - Third Number Billed (D)
  - Intercept Call Completion - Circuit 9 Service
  - Mass Announcement Services
  - Directory Assistance
  - Group Bridging Service
  - Directory Assistance Call Completion (DACC) Calls/Directory Assistance Call Completion
  - Easy Number Service
  - Repeat Calls, Return Calls (per activation) (D)
  - Person-to-Person (D)
  - All other operator Handled Calls
  - Three-Way calling (per activation) (D)
9. Single Line Business Pak may only be used for voice applications and incidental non-broadcast facsimile usage, and may not be used for the transmission of data, for internet connections, or for any other non-voice application. This service may also not be used for autodialing, predictive dialers, or facsimile broadcasting, blasting, or spamming. The Company reserves the right to restrict the number of other services and/or equipment furnished or used in connection with any particular class of service in order to prevent any impairment in the quality of service furnished. If the customer uses this service for any non-eligible purpose, including, but not limited to, the examples noted above, the Company may suspend, restrict or cancel the service.
10. Details on calls made will not be available for this service.
11. Service Connection Charges will be waived in the event a class of service change is required in order to have a Single Line Business Pak.
12. Applicable Service Charges will be waived for customers subscribing to a three-year agreement.

<sup>1</sup> As of March 17, 2012, the Single Line Business Pak will not be provided to new subscribers. It will be provided only to customers who subscribed to the package as of March 16, 2012.

---

BUNDLED/ PACKAGED SERVICES

SINGLE LINE BUSINESS PAK<sup>1</sup> (Continued)

III. TERMINATION LIABILITY

Single Line Business Pak is offered on a one-year or a three-year term agreement.

Early termination of an Single Line Business Pak term agreement by the customer will result in a one-time flat Termination Charge of:

1-year term agreement: \$75

3-year term agreement:

\$125 for default within the 1st year of the term  
\$100 for default within the 2nd year of the term  
\$75 for default within the 3rd year of the term

If the customer cancels any of the unregulated components or all of the Unlimited DTL Single Line Package, the remaining components will revert to the individual rate associated with that component as listed in this Product Guide.

If the Dialtone Line (DTL) is removed, the applicable termination charge shown above will apply.

Customer termination of service within the first 60 days, starting on the Order Completion Date, will result in customer liability for the monthly charges. Termination liability will be waived.

At the end of the term period or any subsequent renewal, the agreement will automatically be renewed for a successive one-year or three-year term at the same terms and conditions, unless either party provides advance notice that it does not wish to renew the term. Each subsequent renewal will allow for a 60-day grace period for the subscriber to unsubscribe from the plan without penalty. Pricing will remain the same during any automatic renewal unless the Company has provided 30 days notice of any change. Customers can move from a one-year to a three-year term without incurring a penalty.

An early termination charge will not apply under the following circumstances:

- Customer moves existing service either to a new location within the same address and/or same building (inside move) or to a new location (outside move) and maintains that service for the remainder of the term;
- Customer renegotiates a new term commitment plan for the same service before the current term commitment expires and the value of the new term commitment is equal to or greater than the remaining value of the current term commitment;  
or
- Customer changes to another service or usage plan or upgrades service or usage under a term commitment, and the value of the new term commitment is equal to or greater than the remaining value of the current term commitment.

IV. RATES AND CHARGES

	<u>Monthly Rate</u>	
	<u>3-Year Term</u>	<u>1-Year Term</u>
Single Line Business Pak	\$65.00	\$65.00
Frontier Broadband Credit	10.00	--

<sup>1</sup> As of March 17, 2012, the Single Line Business Pak will not be provided to new subscribers. It will be provided only to customers who subscribed to the package as of March 16, 2012.

Effective: January 19, 2021

---

BUNDLED/ PACKAGED SERVICES

FTR REGIONAL SELECT DISCOUNT<sup>1</sup>

I. SPECIAL CONDITIONS

The FTR Regional Select Discount (FPB) offers a monthly discounted rate on Frontier Regional Value to qualifying residential customers, subject to the limitations described below. The customer must: 1) establish dial tone service with Frontier or call Frontier to disconnect their Frontier dial tone service and agree to retain such service; 2) agree to subscribe to Frontier Regional Value along with a qualifying unlimited long distance calling plan as described below, and 3) reside in a location not eligible for High Speed Internet or Frontier® FiberOptic Internet products at the time services are established. (C)

Subject to future modification or elimination of the FPB, the discounted rate will be available for as long as the customer:

- remains at the same service address;
- continues to meet the conditions listed above.

Each product must be purchased through and billed by Frontier.

The FTR Regional Select Discount cannot be provided by Frontier during periods of Vacation Service (see Section 4 of this Product Guide). Following the end of any period during which a FPB customer's service is on Vacation Service, the customer will have to re-order the FTR Regional Select Discount.

Failure of the customer to meet any of the conditions listed above will result in immediate termination of the FPB discounted rate.

Customers are limited to one FPB discounted rate at any given time and cannot combine discounts.

There is no charge for eligible customers to enroll in the FPB discounted rate offering.

Qualifying unlimited long distance calling plans must be consistent with the Plan O Service – Unlimited as found in the Frontier Communications of America, Inc. Posted Rates, Terms and Conditions.

FPB will not be provided automatically but will be provided only upon a request by an eligible customer, or upon an eligible customer's acceptance of a Frontier representative's offer or suggestion or recommendation of the service

II. RATES AND CHARGES

	<u>Monthly Discounted Rate</u>
FTR Regional Select Discount	
Frontier Regional Value	\$17.04

<sup>1</sup> Effective March 16, 2013, FTR Regional Select Discount is no longer available for purchase. Existing customers may retain this package in accordance with the terms and conditions described herein.

Effective: May 16, 2018

---

BUNDLED/ PACKAGED SERVICES

FTR REGIONAL CALLING PLAN

I. FEATURE PACKAGE

A FTR Regional Calling Plan customer is eligible to receive a Feature Package at no additional charge when the customer also subscribes to a qualifying unlimited long distance calling plan. The feature package includes the following features:

Call Forwarding  
Three-Way Calling  
One non-regulated product

The Feature Package will automatically be provided to customers newly subscribing to FTR Regional Calling Plan. The Feature Package will be provided to existing FTR Regional Calling Plan customers upon customer request.

If the customer removes FTR Regional Calling Plan or the qualifying unlimited long distance calling plan associated with FTR Regional Calling Plan, the customer will lose the Feature Package.

Qualifying unlimited long distance calling plans must be consistent with the Plan O Service - Unlimited as found in the Frontier Communications of America, Inc. Posted Rates, Terms and Conditions.

Each product must be billed by Frontier.

Periodically, the Company may offer various "save incentives" in the event of a competitive threat. Such incentives may be limited to specific markets, specific dates, specific products or specific pricing plans or customers who have received offers from competing services providers. Term requirements and termination liabilities may be a condition of the Save Incentive offer.

(N)  
|  
(N)

Effective: December 21, 2020

---

BUNDLED/ PACKAGED SERVICES

FTR SOLUTIONS FOR BUSINESS BUNDLE\*

(C)

I. GENERAL

A. FTR Solutions for Business Bundle is an optional business package that includes a network access line (or Communications System), calling features and Voice Messaging service offered for a month-to-month or two-year term commitment as well as three additional line types that are offered on a month-to-month basis or two-year term commitment.

B. FTR Solutions for Business Bundle Main Line <sup>1</sup> includes the following:

One Network Access Line (or Communications System) with touch calling  
Unlimited Local and IntraLATA Toll calling  
Choice of zero to six (0 – 6) of the following calling features <sup>2</sup>:

Call Waiting  
Three-Way Calling  
Call Forwarding  
Caller ID  
Voice Messaging  
Multiline Hunt

C. FTR Solutions for Business Bundle Additional Line <sup>3,4</sup> includes the following:

Additional Bundle Line

- One (1) Communications System Line, or One (1) Network Access Line with Call Waiting, Call Forwarding, Three-Way Calling

Additional Bundle Line-Plus

- One (1) Communications System Line, or One (1) Network Access Line with Call Waiting, Call Forwarding, Three-Way Calling
- Caller ID and Voice Messaging

Additional Bundle Line-Unlimited

- One (1) Communications System Line, or One (1) Network Access Line with Call Waiting, Call Forwarding, Three-Way Calling
- Caller ID and Voice Messaging
- Unlimited Local and IntraLATA Toll calling

<sup>1</sup> One line customers will be provisioned with a network access line.

<sup>2</sup> Features may not be available in all serving areas.

<sup>3</sup> Customers with two or more lines will be provisioned with Communications System lines unless the customer's switch type is not provisioned with Communications System, in which case the additional lines will be provisioned as Business network access lines.

<sup>4</sup> Communications System lines include Call Waiting, Three-Way Calling and Call Forwarding.

\* FTR Solutions for Business Bundle is grandfathered and limited to all existing subscribers at their existing locations.

(N)

Effective: December 21, 2020

---

BUNDLED/ PACKAGED SERVICES

FTR SOLUTIONS FOR BUSINESS BUNDLE\* (Continued)

(C)

II. REGULATIONS

FTR Solutions for Business Bundle is available only where facilities and conditions permit. FTR Solutions for Business Bundle is available only to customers who subscribe to the Company for their Local Usage and IntraLATA Toll calls.

FTR Solutions for Business Bundle is available only on a month-to-month or two-year term agreement.

FTR Solutions for Business Bundle is only available with subscription to a business unlimited nationwide long distance calling plan through Frontier Communications of America, Inc.

FTR Solutions for Business Bundle is available to business customers who subscribe to 25 or fewer lines (voice grade or voice grade equivalent) per location. A maximum of ten (10) lines per customer location can have unlimited calling.

Customers may not combine this package with the Unlimited Dial Tone Line (DTL) Package for Business, the Unlimited Communications System Package for Business, the Single Line Business Pak for Business, Unlimited Local Usage for Business, Unlimited Local and Toll Usage for Business or ICB's (Individual Case base pricing).

FTR Solutions for Business Bundle is not available with the following services:

- ISDN Service Single Line Service
- ISDN Basic Rate Service
- ISDN Primary Rate Service
- Ground Start Lines or Trunks
- Remote Call Forwarding Service
- Foreign Exchange Service
- Foreign Central Office Service
- Foreign Zone Service
- Coin or Pay Telephone Service

FTR Solutions for Business Bundle is not available in combination with other optional calling plans or virtual private network services.

\* FTR Solutions for Business Bundle is grandfathered and limited to all existing subscribers at their existing locations.

(N)

Effective: December 21, 2020

---

BUNDLED/ PACKAGED SERVICES

FTR SOLUTIONS FOR BUSINESS BUNDLE\* (Continued)

(C)

II. REGULATIONS (Continued)

FTR Solutions for Business Bundle does not apply to the following calls or services:

- Collect Calls
- Calling Card
- Time and Weather
- 555,700, 900, 976 Service
- Third Number Billed
- Directory Assistance – Call Completion
- Directory Assistance
- Group Bridging Service
- Emergency Interrupt
- Repeat Calls, Return Calls (per activation)
- Person-to-Person
  
- Intercept Call Completion
- All other operator Handled Calls
- Three-Way Calling (per activation)

Lines with unlimited calling may only be used for voice applications and incidental non-broadcast facsimile usage, and may not be used for the transmission of data, for internet connections, or for any other non-voice application. This service may also not be used for autodialing, predictive dialers, or facsimile broadcasting, blasting, or spamming. The Company reserves the right to restrict the number of other services and/or equipment furnished or used in connection with any particular class of service in order to prevent any impairment in the quality of service furnished. If the customer uses this service for any non-eligible purpose, including, but not limited to, the examples noted above, the Company may suspend, restrict or cancel the service.

Details on calls made will not be available for this service.

Service Connection Charges will be waived in the event a class of service change is required in order to have FTR Solutions for Business Bundle.

Applicable Service Charges will be waived for customers subscribing to a two-year agreement, and for customers who subscribe to a two-year agreement and add lines to an existing FTR Solutions for Business Bundle in order to qualify for the Multi-Line Discount.

\* FTR Solutions for Business Bundle is grandfathered and limited to all existing subscribers at their existing locations.

(N)

Effective: December 21, 2020

---

BUNDLED/ PACKAGED SERVICES

FTR SOLUTIONS FOR BUSINESS BUNDLE\* (Continued)

(C)

II. REGULATIONS (Continued)

Multi-Line Discount <sup>1</sup> – A multi-line discount, as specified in the Rates section, applies to the FTR Solutions for Business Bundle Additional Bundle Line(s)-Plus or Additional Bundle Line(s)-Unlimited as follows:

1. The discount will be provided on the Additional Bundle Line(s)-Plus or Additional Bundle Line(s)-Unlimited when the total lines in the bundle equal four or more. The discount will be provided beginning with the fourth qualifying line up to the bundle maximum of 25 lines. The main line and the second and third lines are not eligible.
2. Customers with four or more FTR Solutions for Business Bundle lines prior to April 17, 2011, must add at least one new line to qualify for the Multi-Line Discount.
3. Only one Multi-Line Discount shall apply per line. If any lines are removed from the FTR Solutions for Business Bundle such that the account has less than four lines, the Multi-Line Discount will be automatically removed.

III. FTR SOLUTIONS FOR BUSINESS BUNDLE SATISFACTION GUARANTEE

If the customer notifies Company within the first thirty (30) days of service installation that it is not satisfied with the service(s) and wishes to discontinue the service(s), the customer will be entitled to a full credit of one (1) month's monthly recurring charge (MRC), or portion thereof if subscription is less than thirty (30) days. The Customer will also be entitled to a full credit of any one-time charges directly associated with the establishment of the service.

- This offer applies on two-year term subscriptions for new customers only. It does not apply to customers subscribing to the service on a month-to-month basis.
- Early termination liability will be waived for customers requesting discontinuation of the service pursuant to this offer.
- No customer will be entitled to discontinue service pursuant to this offer more than once per service.
- The Company will remove the service(s) from the account of a customer requesting discontinuation pursuant to this offer.
- The customer is responsible for notifying the Company to disconnect the service(s) within thirty (30) calendar days of installation.
- The monthly recurring charges and one-time charges directly associated with the establishment of service will be applied as a credit on the bill of a customer discontinuing service pursuant to this offer.
- Credits are limited to the charges identified above. No credits will be issued for other charges billed to the customer, including but not limited to toll and local usage charges, E911 surcharges, or other surcharges.
- This offer applies only to the charges for the service as a whole and not any charges for optional features offered with this service.
- This offer does not extend to any Customer Provided Equipment (CPE) used in conjunction with this service, nor does it apply to Time and Material charges.
- This offer does not apply to service(s) to be used for less than thirty (30) consecutive days.
- This offer does not apply to any customers with voice services already provisioned.

<sup>1</sup> Multi-Line Discount will be limited to customers with the Multi-line discount prior to February 4, 2012.

\* FTR Solutions for Business Bundle is grandfathered and limited to all existing subscribers at their existing locations.

(N)



Effective: December 21, 2020

---

BUNDLED/ PACKAGED SERVICES

FTR SOLUTIONS FOR BUSINESS BUNDLE\* (Continued)

(C)

IV. TERMINATION LIABILITY<sup>1</sup>

FTR Solutions for Business Bundle is offered on a month-to-month or two-year term agreement.

Early termination of a Solution for Business Bundle term agreement by the customer during any month of the two-year term will result in an early termination charge except as noted in the FTR Solutions for Business Bundle Satisfaction Guarantee or as described below:

PLAN 1 - one-time flat Termination Charge of \$50.00.

The customer must contact the Company prior to the end of the term agreement in order to renew it. Upon renewal, the customer shall pay the prevailing rate for the term period selected.

If the customer does not renew the term agreement before it expires, the customer shall continue on a month-to-month basis and shall pay the prevailing monthly rate, on a monthly basis, until the customer cancels the service or requests a new term agreement. Customers will be subject to all prevailing rules and regulations of the package, including rate changes. Payment of such rate shall constitute the customer's acceptance of the continued service.

PLAN 2 - The amount of the early termination charge will be 100% of the monthly recurring charge(s) (MRC), excluding any promotional discounts, for the line(s) being terminated multiplied by the remainder of the term in months. The remainder of the term will be the number of days left in the 24-month term divided by 30.

The term of all lines subscribed to or renewed under Plan 2 and within the same account, will be coterminous based upon the date of the first line established.

At the end of each term, the plan will automatically renew for another two-year term under the same terms, except that the monthly rate will be adjusted to the prevailing plan rate in effect at the time of renewal. Alternately, the customer may call anytime within 30 days before the end of a term to arrange for termination of the service or conversion to a month-to-month service at the end of the then current term. Customers may also terminate their term plan within the first 60 days following an automatic renewal and the early termination charge will be waived.

Solutions for Business lines subscribed to under Termination Liability Plan 2 may not be combined with other voice services or features under a term commitment. Other voice services and features may only be combined with lines under Termination Liability Plan 2 when these other voice services and/or features are purchased on a month-to-month basis.

Lines within the same FTR Solutions for Business Bundle must be either Plan 1 or Plan 2.

<sup>1</sup> Termination Liability found in Section 2 of the Product Guide does not apply to FTR Solutions for Business Bundle.

\* FTR Solutions for Business Bundle is grandfathered and limited to all existing subscribers at their existing locations.

(N)

Effective: December 21, 2020

BUNDLED/ PACKAGED SERVICES

FTR SOLUTIONS FOR BUSINESS BUNDLE\* (Continued)

(C)

IV. TERMINATION LIABILITY <sup>1</sup> (Continued)

The early termination of a Solution for Business Bundle term agreement by the customer during any month of the two-year term will result in an early termination charge except as noted in the FTR Solutions for Business Bundle Satisfaction Guarantee or as described below:

- Customer moves existing service either to a new location within the same address and/or same building (inside move) or to a new location (outside move) and maintains that service for the remainder of the term;
- Customer renegotiates a new term commitment plan for the same service before the current term commitment expires and the value of the new term commitment is equal to or greater than the remaining value of the current term commitment; or
- Customer changes to another service or usage plan or upgrades service or usage under a term commitment, and the value of the new term commitment is equal to or greater than the remaining value of the current term commitment.
- FTR Solutions for Business Bundle Additional Lines will be offered on a month-to-month or two-year term basis. Additional lines on a month-to-month basis may be added and deleted without termination charges as long as the main line remains on the account. Additional lines provided on a two-year term basis are subject to early termination charges as described for Plan 2 above.

V. RATES AND CHARGES

	<u>Monthly Rate</u>	
	<u>Month-to-Month</u>	<u>2-Year Term</u>
FTR Solutions for Business Bundle Main Line <sup>2</sup>	\$66.00	\$68.00
FTR Solutions for Business Bundle Main Line <sup>2</sup>	\$59.00	\$61.00 <sup>3</sup>
 <u>Monthly Credit</u>		
	<u>Month-to-Month</u>	<u>2-Year Term</u>
Frontier Broadband Credit	\$6.00	\$16.00 <sup>3</sup>

<sup>1</sup> Termination Liability found in Section 2 of the Product Guide does not apply to FTR Solutions for Business Bundle.

<sup>2</sup> Rate grandfathered to existing customers as of February 4, 2012.

<sup>3</sup> This rate shall continue to apply to a customer's lines, purchased prior to February 4, 2012, when the customer elects on or after December 14, 2014, to subscribe to a new two-year term with Plan 2 termination liability as described in this Section, IV Termination Liability preceding.

\* FTR Solutions for Business Bundle is grandfathered and limited to all existing subscribers at their existing locations.

(N)

Effective: December 21, 2020

BUNDLED/ PACKAGED SERVICES

FTR SOLUTIONS FOR BUSINESS BUNDLE\* (Continued)

(C)

V. RATES AND CHARGES (Continued)

	<u>Monthly Rate</u>
FTR Solutions for Business Bundle Additional Line	
Additional Bundle Line - Month-to-Month	\$24.00
Additional Bundle Line - Month-to-Month - Subscribed On or After to June 1, 2014	\$29.00
Additional Bundle Line - Two-Year Term - Subscribed On or After to June 1, 2014 <sup>2</sup>	\$24.00
Additional Bundle Line-Plus - Month-to-Month	\$35.00
Additional Bundle Line-Plus - Month-to-Month - Subscribed On or After to June 1, 2014	\$40.00
Additional Bundle Line Plus - Two-Year Term - Subscribed On or After to June 1, 2014 <sup>2</sup>	\$35.00
Additional Bundle Line-Unlimited - Month-to-Month - Subscribed Prior to February 4, 2012 <sup>1</sup>	\$59.00 <sup>3</sup>
Additional Bundle Line-Unlimited - Month-to-Month - Subscribed on or after February 4, 2012	\$66.00
Additional Bundle Line-Unlimited - Month-to-Month - Subscribed on or after June 1, 2014	\$71.00
Additional Bundle Line-Unlimited - Two-Year Term - Subscribed on or after June 1, 2014 <sup>2</sup>	\$68.00
	<u>Monthly Credit</u>
Frontier Broadband Credit (applies to Additional Bundle Line-Unlimited only)	\$26.00
Frontier Broadband Credit (applies to Additional Bundle Line-Unlimited only) <sup>1</sup>	\$34.00 <sup>3</sup>
	<u>Monthly Multi-Line Discount Credit</u>
Additional Bundle Line-Plus, per line	\$ 8.00
Additional Bundle Line-Unlimited, per line	10.00

<sup>1</sup> Rate grandfathered to existing customers as of February 4, 2012

<sup>2</sup> Plan 2 termination liability fees apply, as described in this Section IV Termination Liability preceding.

<sup>3</sup> This rate shall continue to apply to a customer's lines, purchased prior to February 4, 2012, when the customer elects on or after December 14, 2014, to subscribe to a new two-year term with Plan 2 termination liability as described in this Section IV Termination Liability preceding.

\* FTR Solutions for Business Bundle is grandfathered and limited to all existing subscribers at their existing locations.

(N)

Effective: December 20, 2017

---

BUNDLED/ PACKAGED SERVICES

FRONTIER COMMERCIAL VOICE UNLIMITED <sup>1</sup> – Grandfathered as of December 20, 2017

(C)

A. APPLICABILITY

Applicable to Single-party Business Flat rate service.

B. GENERAL

Frontier Commercial Voice Unlimited is a bundled offering available to Business customers that subscribe to a maximum of twelve Single Party Business Lines per customer location. The bundle includes the following components: one Basic Flat Rate Access Line, Custom Calling features and Unlimited Extended Area Service. The bundle also included the Subscriber Line charge and the Access Recovery Charge that is tariffed in the appropriate FCC tariff.

Basic Bundle

Single Party Flat Rate Access Line  
Basic Call Forward  
Call Forward Busy  
Call Forward No Answer  
Call Waiting/Cancel Call Waiting  
Caller ID  
Call Waiting ID  
3 Way Calling  
Hunting

C. SPECIAL CONDITIONS

1. The bundle is available only where facilities and operating systems are available and technically feasible.
2. The features are provided subject to their individual service regulations as specified in the applicable sections of the Product Guide.
3. Call Detail for Unlimited Extended Area Service will not be displayed on the customer's monthly telephone bill.
4. Frontier Commercial Voice Unlimited includes basic local service and non-basic local services. Nonpayment or partial payment of the basic local service charge within the bundle may result in disconnection of your basic local service.
5. Customers may add or delete any features offered within the bundle without incurring a Service Connection Charge.
6. The bundle rate will appear as a single line item on the customer's bill.
7. The bundle is available only to customers who are served from a central office in which services in the bundle are offered and can be provided by the Company to the customer.
8. The bundle cannot be used in association with a Residential Line, PBX Service, Remote Call Forwarding Service, ISDN Service, Toll Free Service, and Foreign Exchange Services.
9. The bundle is offered on a month-to-month, one or two year term basis.

<sup>1</sup> This service offering is limited to existing subscribers.

(N)

Effective: December 20, 2017

---

BUNDLED/ PACKAGED SERVICES

FRONTIER COMMERCIAL VOICE UNLIMITED <sup>1</sup> – Grandfathered as of December 20, 2017 (Continued)

(C)

C. SPECIAL CONDITIONS (Continued)

10. Customers in a term plan will be charged a termination fee for cancelling before the term is up. The early termination fee is the monthly charge times the remaining months in the term.
11. At the end of the one or two year term, customers will be moved to the month to month pricing.

D. RATES AND CHARGES

1. Interstate End User Subscriber Line charge and Access Recovery Charges are included in the bundle. Other applicable surcharges and taxes will be billed separately from and are in addition to the bundle rate.
2. Unless otherwise stated elsewhere in this section, Service Charges apply to the installation of individual components of the bundle.

<u>Basic Bundle</u>	<u>Monthly Rate</u>
Month to Month	\$33.00
One Year Term	\$28.00
Two Year Term	\$28.00

<sup>1</sup> This service offering is limited to existing subscribers.

(N)

Effective: December 16, 2018

---

BUNDLED/ PACKAGED SERVICES

FRONTIER ONEVOICE

(N)

A. GENERAL

Frontier OneVoice is a bundled offering available to Business customers that subscribe to Single Party Business Line. The bundle includes the following components: one Basic Flat Rate Access Line, Custom Calling features, and Unlimited Extended Area Service. Customers may select any or all of the following services and features for a monthly rate charge.

1. Features and Services

Single Party Flat Rate Access Line  
Call Forwarding Busy/No Answer  
Unlimited Extended Area Service  
Call Waiting/Cancel Call Waiting  
Caller ID  
Anonymous Call Rejection  
Call Forward  
Multi-line Hunting  
3-Way Calling

2. Premium Feature Package

Call Return (\*69)  
Call Transfer  
Distinctive Ring  
Busy Number Redial (\*66)  
Priority Call  
Selective Call Forward  
Selective Call Acceptance  
Selective Call Rejection  
Speed Call 30

B. REGULATIONS

1. The bundle is available only where facilities and operating systems are available and technically feasible.
2. The features are provided subject to their individual service regulations as specified in the applicable schedules of the tariff.
3. Call detail for Unlimited Extended Area Service will not be displayed on the customer's monthly telephone bill.

(N)

Effective: March 1, 2024

---

BUNDLED/ PACKAGED SERVICES

FRONTIER ONEVOICE (Continued)

B. REGULATIONS (Continued)

4. Partial payment of the basic local service charge within the bundle may result in disconnection of your basic local service.
5. Customers may add or delete any features offered within the bundle without incurring a Service Connection Charge.
6. The bundle rate will appear as a single line item on the customer's bill.
7. The bundle is available only to customers who are served from a central office in which services in the bundle are offered and can be provided by the Company to the customer.
8. The bundle cannot be used in association with a Residential Line, Remote Call Forwarding Service, ISDN Service, Centrex, and Foreign Exchange Services.
9. The bundle is offered on a month-to-month, or one year term basis. (D)

C. RATES AND CHARGES

1. Surcharges and taxes will be billed separately from and are in addition to the bundle rate.
2. New customers will incur a non-recurring charge up to \$95.00 per account. This charge supersedes the Initial Order and Connection charges.

	<u>Monthly Rate</u>	
Monthly Rate Basic Bundle	\$57.99	(I)
Term Price with 1 year commitment	\$42.99	(I) (D)
Premium Feature Package	\$9.99	

Effective: September 20, 2020

---

BUNDLED/ PACKAGED SERVICES

FRONTIER RESIDENTIAL UNLIMITED VOICE SERVICE

(N)

A. GENERAL

The Frontier Residential Unlimited Voice Service is a bundle offering available to residential customers. The bundle includes one Residential Local Exchange Network Access Line, Unlimited Extended Area Service and the customer's choice of the features and services listed below. This bundle also includes an unlimited long-distance component through Frontier Communications Online and Long Distance, Inc. The description and pricing for this component are located in the Frontier Communications of America Domestic price list.

<u>Basic Bundle</u>	
Local Exchange Network Access Line	Call Waiting ID
Caller ID with Name	Anonymous Call Rejection
Unlimited Extended Area Service	Basic Voicemail
Call Waiting/Cancel Call Waiting	Touchtone

B. REGULATIONS

1. The bundle is available only where facilities and operating systems are available and technically feasible.
2. The features are provided subject to their individual service regulations as specified in the applicable sections of the Tariff.
3. When the customer disconnects any component of the bundle, the remaining components of the bundle will be billed at their individually Tariffed rates.
4. Non-payment or partial payment of the bill may result in the removal of the services that are included in the bundle in accordance with existing Tariff rules.
5. Customers may add or delete any features offered in the bundle without a service order charge.
6. No discounts will be given to subscribers that do not use all the features or have some features turned off.
7. The bundle is offered on a month-to-month basis.
8. The bundle will appear as a single line item on the bill.
9. The bundled rate includes all available Extended Area Service (EAS) calling, both mandatory and optional, in exchanges where EAS is offered.

(N)



Effective: September 20, 2020

---

BUNDLED/ PACKAGED SERVICES

FRONTIER RESIDENTIAL UNLIMITED VOICE SERVICE (Continued)

(N)

B. REGULATIONS (Continued)

10. Call detail for Extended Area Service will not be displayed on the customer's monthly telephone bill.
11. A customer selecting this bundle is required to subscribe to a Frontier Long Distance company and must purchase a qualifying long-distance bundle located in the Frontier Communications of America Domestic Price List.

C. RATES AND CHARGES

1. All other surcharges and taxes apply and will be billed in addition to the bundle.
2. An Activation charge of \$35.00 will replace the Initial Service Order and Central Office Connection Charge.
3. Frontier Residential Unlimited Voice Service is provided at the following rates:

	<u>Monthly Rate</u>
Frontier Residential Unlimited Voice Service	\$20.00

(N)

Effective: May 23, 2021

---

BUNDLED/ PACKAGED SERVICES

FRONTIER UNLIMITED VOICE AND FEATURE BUNDLE

(N)

A. GENERAL

The Frontier Unlimited Voice and Feature Bundle is a bundle offering available to residential customers. The bundle includes one Residential Local Exchange Network Access Line, Unlimited Extended Area Service and the customer's choice of the features and services listed below. This bundle also includes an unlimited long-distance component through Frontier Communications Online and Long Distance, Inc. The description and pricing for this component are located in the Frontier Communications of America Domestic price list.

<u>Basic Bundle</u>	
Local Exchange Network Access Line	3 Way Calling
Caller ID with Name	Basic Call Forward
Unlimited Extended Area Service	Distinctive Ring
Call Waiting/Cancel Call Waiting	Priority Call
Call Waiting ID	*66 Busy Number Redial
Anonymous Call Rejection	*69 Call Return
Basic Voicemail (Non-Regulated)	Selective Call Acceptance
Touchtone	Selective Call Rejection
Selective Call Forward	Speed Call 30
Wire Care (Non-Regulated)	Directory Listing

B. REGULATIONS

1. The bundle is available only where facilities and operating systems are available and technically feasible.
2. The features are provided subject to their individual service regulations as specified in the applicable sections of the Tariff.
3. Non-payment or partial payment of the bill may result in the removal of the services that are included in the bundle in accordance with existing Tariff rules.
4. Customers may add or delete any features offered in the bundle without a service order charge.
5. No discounts will be given to subscribers that do not use all the features or have some features turned off.
6. The bundle is offered on a month-to-month basis.
7. The bundle will appear as a single line item on the bill.
8. The bundled rate includes all available Extended Area Service (EAS) calling, both mandatory and optional, in exchanges where EAS is offered.

(N)

Effective: May 23, 2021

---

BUNDLED/ PACKAGED SERVICES

FRONTIER UNLIMITED VOICE AND FEATURE BUNDLE (Continued)

(N)

B. REGULATIONS (Continued)

9. Call detail for Extended Area Service will not be displayed on the customer's monthly telephone bill.
10. A customer selecting this bundle is required to subscribe to a Frontier Long Distance company and must purchase a qualifying long-distance bundle located in the Frontier Communications of America Domestic Price List.
11. Directory Listing Feature-Customer can pick from Additional Listing, Extra Line of Information, Non List, Non published and foreign listing.
12. Wire Care Services include work performed on or at the customer premises by the Utility or a Utility representative at the customer's request and is not covered by other charges. The Bundle includes work preparation, actual work, materials and cleanup. Frontier Wire Care covers all wiring, jacks, dispatch charges, labor and materials for each telephone line in the home. In addition, Frontier Wire Care covers any damage to the phone line that was caused by lightning, accidental customer damage and problem isolation within the home.

C. RATES AND CHARGES

1. All other surcharges and taxes apply and will be billed in addition to the bundle.
2. An Activation charge of \$35.00 will replace the Initial Service Order and CO Connection Charge.
3. Frontier Unlimited Voice and Feature Bundle is provided at the following rates:

	<u>Monthly Rate</u>
Frontier Unlimited Voice and Feature Bundle	\$50.00

(N)

Effective: April 1, 2016

---

PROMOTIONAL OFFERINGS

TABLE OF CONTENTS

	<u>SHEET NO.</u>
I. GENERAL	1
II. DESCRIPTION	1
III. SPECIAL CONDITIONS	1

Effective: April 1, 2016

---

PROMOTIONAL OFFERINGS

I. GENERAL

A. Applicability

Applicable to promotional offerings of all network and exchange services as specified in this section of the Product Guide.

B. Territory

Within the exchange area of all exchanges.

II. DESCRIPTION

Promotional pricing of network and exchange services may be offered to the Utility's Residential and Business customers. These promotions are not intended for resale.

The Utility may waive and/or discount specific rates and/or charges, provide customers with credits based on meeting certain conditions, or offer services under different terms and conditions, or offer other incentives to purchase services as specified in the offer.

III. SPECIAL CONDITIONS

A. GENERAL

1. Promotional pricing of services shall be subject to and offered only where facilities and operating conditions permit.
2. Promotional offerings shall be limited to serving central offices designated by the Utility.
3. The method of customer notification of the promotional offering shall be determined by the Utility.
4. From time to time, third parties may participate in a promotion, conducted by the Utility, by offering certain merchandise and/or services at their discretion. The Utility may include the third party offers in advertising material sent to customers. The discounts, waivers, credits, and other incentives may also be offered by the Utility to customers in conjunction with third party promotions. In addition, third parties may condition their offers, whether discounted or not, on the purchase by a customer of Utility's products and/or services.
5. Customers may cancel at any time during or at the conclusion of the promotional period without penalty. Minimum charges for service as set forth in the General Exchange Tariff, Schedule No. D&R, Rule No. 9 are applicable to promotional offerings.

Effective: October 17, 2023

PROMOTIONAL OFFERINGS

V. PROMOTIONAL OFFERINGS

The Company may, from time to time, engage in special promotional offerings designed to attract new customers or to increase existing customer awareness of a particular service. These offerings may include, but are not limited to, waiving or reducing the applicable charges for the promoted service. The promotional offerings are subject to the availability of the services and may be limited to a specific geographical area, to a subset of a specific market group, the duration, and the date and times of the offering. (N)

**Business Service Promotion** beginning October 1, 2016 through March 31, 2017, qualifying business customers that, at the time they accept this promotional offering, meet the following criteria will receive the monthly credit(s) specified below on their monthly telephone bill. (N)

Eligible customers are defined as customers new to Frontier (establishing a new account) that agree to subscribe to the following combination of services.

Qualifying services are:

- One or more new Business Lines under the 24 month term or one or more new Communications System lines under the 24 month term.
- A new Unlimited Local Usage for Business month-to-month plan, or a new Unlimited Local and Toll Usage for Business month-to-month plan.
- A qualifying long distance calling plan.
- Feature Package 1, 2, or 3 for Unlimited Local and Toll Usage for Business.

MONTHLY CREDITS

<u>Qualifying Service Combinations</u>	<u>Area</u>	<u>Business Line or Communications System Term</u>	<u>Monthly Credit</u>
Business Line + Unlimited Local Usage	1	2 Year	\$43.01
Business Line + Unlimited Local Usage	2	2 Year	50.96
Business Line + Unlimited Local and Toll Usage	1	2 Year	24.01
Business Line + Unlimited Local and Toll Usage	2	2 Year	31.96
Business Line + Unlimited Local and Toll Usage, Feature Packages, LD	1	2 Year	57.01
Business Line + Unlimited Local and Toll Usage, Feature Packages, LD	2	2 Year	64.96
Communications System Line + Unlimited Local Usage	All	2 Year	47.96
Communications System Line + Unlimited Local and Toll Usage	All	2 Year	28.96
Communications System Line + Unlimited Local and Toll Usage, Feature Packages, LD	All	2 Year	42.96

<sup>1</sup> Areas defined in Section 4, Sheet 2, of this Product Guide

<sup>2</sup> Areas defined in Section 4, Sheet 3, of this Product Guide

Terms and Conditions

Applicable credits will be applied per line for the duration of the customer's Business Line or Communications System line term plan.

This promotion may not be applied to existing Business accounts.

Qualified businesses will also receive a waiver of the applicable Service Charges.

The monthly credits can be applied on a maximum combined total of ten lines with either Unlimited Local Usage for Business or Unlimited Local and Toll Usage for Business.

Effective: December 16, 2018

---

PROMOTIONAL OFFERINGS

V. PROMOTIONAL OFFERINGS (Continued)

**Frontier Commercial Voice Unlimited Promotion** beginning May 22, 2017 through August 19, 2017

New Frontier business customers that sign up for Frontier Commercial Voice Unlimited between May 22, 2017 and August 19, 2017 with a term commitment of 1, 2 or 3 years will have all standard non-recurring charges waived for the initial set up and be given a \$5.00 credit per month per line for the length of the contract. New is defined as not having Frontier service in the past ninety days.

**Regional Essentials Save Promotion** beginning August 21, 2017 through November 18, 2017

Effective August 21, 2017 thru November 18, 2017, Regional Essentials customers that plan to cancel because of a competitive threat will be eligible to receive a:

- \$5.00 loyalty credit for sixty months or
- \$10.00 loyalty credit for forty eight months or
- \$20.00 loyalty credit for a thirty six month term or
- \$30.00 loyalty credit for a twenty four month term

**Frontier Commercial Voice Unlimited Promotion** beginning September 15, 2017 through December 13, 2017

New Frontier business customers that sign up for Frontier Commercial Voice Unlimited between September 15, 2017 and December 13, 2017 with a term commitment of 1 year will have all standard non-recurring charges waived for the initial set up and be given a \$5.00 credit per month per line for the length of the contract. New is defined as not having Frontier service in the past ninety days.

**Regional Essentials Save Promotion** beginning November 19, 2017 through December 31, 2017

Effective November 19, 2017 through December 31, 2017, Regional Essentials customers that plan to cancel because of a competitive threat will be eligible to receive a:

- \$5.00 loyalty credit for sixty months or
- \$10.00 loyalty credit for forty eight months or
- \$20.00 loyalty credit for a thirty six month term or
- \$30.00 loyalty credit for a twenty four month term

**FTR Regional Calling Plan Promotion** beginning July 22, 2018 through October 19, 2018

Effective July 22, 2018 through October 19, 2018 new FTR Regional Calling Plan customers who purchase qualifying broadband services will be given a \$27.02 discount per month for two years.

**Regional Essentials Save Promotion** beginning December 16, 2018 through December 31, 2025

Effective December 16, 2018 through December 31, 2025, Regional Essentials customers that plan to cancel because of a competitive threat will be eligible to receive a:

- \$20.00 loyalty credit for a thirty-six-month term or
- \$30.00 loyalty credit for a twenty-four-month term

(N)

(N)

Effective: January 19, 2021

---

PROMOTIONAL OFFERINGS

V. PROMOTIONAL OFFERINGS (Continued)

**Business Service Promotion** beginning April 1, 2016 through September 30, 2016, qualifying business customers that, at the time they accept this promotional offering, meet the following criteria will receive the monthly credit specified below on their monthly telephone bill.

Eligible customers are defined as customers new to Frontier (establishing a new account) that agree to subscribe to the following combination of services.

Qualifying services are:

1. Unbundled Service

One or more new Business Lines or one or more new Communications System lines, under a 24 month term, with unlimited local, intralata toll and unlimited nationwide Long Distance, including the calling features Caller ID, Call Waiting, Call Forwarding, Three Way Calling and voicemail.

Customers who receive a bundle discount for subscribing to a Frontier® FiberOptic Internet or HSI product are ineligible for this promotion. (C)

Discount     \$19.01

2. Bundled Service

New Customers who subscribe to Solutions for Business with Internet will receive a discount for 24 months (for customers with a two year term), or 12 months (for customers on a month to month plan) if the customer orders a total of three or more lines (Main Line and at least Two Additional, either Basic or Unlimited or any combination of these) or a Main Line with one Unlimited Additional line).

For all qualifying additional lines                      Month to Month Option

Basic Line	\$3.00
Unlimited Line	10.00

For all qualifying additional lines                      Two Year Option

Basic Line	\$8.00
Unlimited Line	15.00

Terms and Conditions

Customers may receive one promotional discount for each line purchased, (then these terms):

- Customers must continue to subscribe to the line and features as described above for the duration of the line term in order to continue to receive the monthly bottom of the bill credit.
- Customers will be subject to the termination liability associated with each term plan.
- Customers who currently subscribe to a Frontier business bundle are not eligible to receive this promotional offer.
- This promotional offer cannot be combined with any other discount or promotion except as authorized by Frontier.
- Frontier reserves the right to change the end date or other terms or conditions of the promotion before its expiration date.
- Qualifying long distance plan must be consistent with the Business Unlimited Long Distance Service Bundled Service Option in the Frontier Communications of America, Inc. Product Guide for Domestic Services.



Effective: August 22, 2021

---

PROMOTIONAL OFFERINGS

V. PROMOTIONAL OFFERINGS (Continued)

**Frontier OneVoice**

Between August 22, 2021 and November 19, 2021, New fiber-based Frontier OneVoice customers who purchase a qualifying broadband service will be given a \$29.99 discount for the first local OneVoice line. Customers must agree to a two year term that provides a two (2) year Price Protection Plan. Installation charges for this service will be waived. Promotion offered where technically feasible.

(N)

(N)

Effective: April 1, 2016

---

COMPETITIVE RESPONSE

TABLE OF CONTENTS

	<u>SHEET NO.</u>
I. VOICE DISCOUNT PLAN OFFER	
A. General	1
B. Special Conditions	1
II. BUSINESS CUSTOMER ACQUISITION/ SAVE/ WINBACK OFFER	
A. General	2
B. Regulations	2

Effective: January 1, 2021

---

COMPETITIVE RESPONSE

I. VOICE DISCOUNT PLAN

A. GENERAL

An incentive for customers to a) remain with the Company's local exchange service when they indicate that they intend to disconnect their Frontier primary or additional lines, or, b) change to Frontier California Inc. for local service from another service provider, or c) establish dial tone service with Frontier. In addition, customers who have changed their local service from another provider to Frontier, having initiated local service with Frontier within the past 30 days, and specifically request these rates in response to direct mailings, advertising or other Frontier marketing activity, or customers who contact Frontier citing competitor's offers or otherwise indicate potential future disconnection based on price considerations will also be eligible for this offer.

Customers that have, or will be purchasing, Frontier Online High Speed Internet service or Frontier® FiberOptic Internet service but no local service from Frontier and accept this offer in response to a direct mailing, advertising, or other Frontier marketing activity will also be eligible for this offer. (C)

B. SPECIAL CONDITIONS

1. Qualifying customers on the initial term of this offer, and who have or agree to purchase Frontier Regional Value, will receive a credit on their Frontier bill of \$32.05 per month for twenty-four months. After the initial term expires the credit will be \$25.05
2. Qualifying customers who have or agree to purchase Frontier Regional Value bundled with a qualifying unlimited long distance calling plan<sup>2</sup> will receive a credit on their Frontier bill of:
  - (a) \$18.00 per month for subscribers on a month-to-month renewal of this offer, except those who had an existing package<sup>3</sup> will receive a \$13.00 per month discount.
  - (b) \$25.00 per month for twenty-four months for subscribers on the initial term of this offer, except existing package<sup>3</sup> subscribers will receive a \$20.00 per month discount.
3. Qualifying customers who have or agree to purchase FTR Regional Calling Plan Bundled with a qualifying unlimited long distance calling plan<sup>1</sup> will receive a credit on their Frontier bill of:
  - (a) \$10.00 per month for subscribers on a month-to-month renewal of this offer, except those who had an existing package<sup>3</sup> will receive a \$5.00 discount.
  - (b) \$17.00 per month for twenty-four months for subscribers on the initial term of this offer, except existing package<sup>3</sup> subscribers will receive a \$12.00 discount.

This offer is not available to employees of Frontier.

After the initial twenty-four (24) month term, customers will automatically renew at the renewal rates specified herein on a month-to-month basis.

This offer is not transferable or redeemable for cash.

This offer may not be combined with any other discount or promotion except as authorized by Frontier. It is limited to one promotional offer per customer line, not to exceed two lines billed on the same bill.

If, prior to the end of the 24-month term, the customer removes the qualifying product from their account, the customer will lose the associated discount.

<sup>1</sup> To be implemented on a full bill period basis on or after March 21, 2015.

<sup>2</sup> Qualifying unlimited long distance calling plans must be consistent with the Plan O Service – Unlimited rates terms and conditions as found in the Frontier Communications of America, Inc. Long Distance Service Catalog.

<sup>3</sup> Customers who prior to taking this offer had an existing package: Local Package, FTR Frontier Local Package Pack, Frontier Local Package Basic, Frontier Local Package Prime, FTR Regional Package Unlimited, Frontier Regional Value and FTR Regional Calling Plan.

Effective: April 1, 2016

---

## COMPETITIVE RESPONSE

### II. BUSINESS CUSTOMER ACQUISITION/ SAVE/ WINBACK OFFER

#### A. GENERAL

Effective February 12, 2014, as dictated by competitive market conditions, Frontier may make various offers to business customers to attract, retain, or reacquire them as Frontier local exchange customers.

#### B. REGULATIONS

1. Qualified customers are new, existing, or former business customers who cite a competitive offer or are contemplating disconnecting their Frontier service but agree to retain their Frontier local exchange service; or as a direct result of Frontier's outbound telemarketing, direct mail campaigns, or other marketing campaigns, change their local service provider back to Frontier; or as a direct result of Frontier's outbound telemarketing, direct mail campaigns, or other marketing campaigns, subscribe to Frontier local exchange service.
2. Qualified customers may be offered credits, discounts, gift certificates, or other items of equivalent monetary value. No customer will receive a credit, discount, gift certificate, or other items of equivalent monetary value that results in a price lower than the incremental cost of the subscribed services.
3. Qualified Frontier business customers must have annual Frontier local exchange service billing of less than \$25,000 per year.
4. Qualified customers may be offered credits, discounts, gift certificates, or other items of equivalent monetary value equal to a discount not to exceed 40% of the customer's local exchange service spend level. No individual customer will receive any combination of discounts worth more than 40% of their local exchange service spending level during any consecutive 12-month period.

Effective: April 1, 2016

---

CENTREX SERVICE

TABLE OF CONTENTS

SHEET NO.

I. SPECIAL CONDITIONS

A. General	1
B. Centrex Feature Packages List	2
C. Features	2
D. Optional Feature Definitions	8
E. Direct Inward Dialing (DID)	15
F. Dormitor Service	15
G. Automatic Route Selection (ARS)/Flexible Route Selection (FRS)	16
H. Message Detail Recording (MDR)	16
I. Authorization Codes	16
J. Code Call Access	16
K. Dication Access and Control	16
L. Preferential Hunting	16
M. Priority Queuing	17
N. Stop Hunt	17
O. Terminal Make Busy	17
P. Time of Day Routing	17
Q. Exchange and Toll Message Diverting	17
R. Direct connect Service	17
S. Instant Call Accounting (ICA)	18
T. Customer Moves and Changes (CMAC)	19
U. Assume Dial "9"	20
V. Discount Pricing Plans (DPP)	20
W. Termination LiabilityCharge Formula	22
X. Centrex Automatic Call Distribution/Management Information System (ACD/MIS)	23
Y. Multilocation Centrex Service	31
Z. Centrex Communications System Service	36

II. RATES AND CHARGES

A. Optional Features	47
B. Station Line Discount Pricing Plan (DPP)	56
C. Centrex Automatic Call Distribution/Management Information System (ACD/MIS)	60
D. Multilocation Centrex Service	61
E. Centrex Communications System Service	64

Effective: April 1, 2016

---

## CENTREX SERVICE

### I. SPECIAL CONDITIONS

#### A. GENERAL

Centrex is an arrangement whereby certain basic and optional features, as shown under Rates above and Special conditions following, are provided from central office switching equipment located on the Company's property.

A Centrex station line consists of Direct Inward and Outward Dialing capability and includes the application of either Feature Package 1000, 2000, 3000, or Centrex CLASS rates. A Centrex station line cannot be used in lieu of a DID-DOD trunk or PBX trunk.

A single Centrex station lines may constitute a business group.

All existing Product Guide terms, conditions, rates and charges associated with the conversion will apply.

A customer may have additional locations, within the same serving area of the same central office provided the additional locations are those of the same customer, or the customer's legal owner and/or parent, subsidiary or affiliate. Schools, hospitals and government entities are excluded from the conditions of this paragraph.

A Customer Group is defined as the dedicated portion of a stored program within the central office switching equipment that provides Centrex to an individual customer.

A Customer Group associated with the month-to-month term will not incur Basic Termination Liability (BTL).

Centrex features are offered only in central offices (C.O.s) where facilities and C.O. capabilities exist to provide the service and/or features.

The Company will determine the C.O. system configuration to conform to the Company's standards. Any request to deviate from these standards will be examined on an individual case basis.

The provision of standard features and/or optional features is controlled by the capability and capacity of the switching system used; therefore, all of the basic and optional features may not be available in all central offices.

One directory listing is provided without charge for each Centrex system. Additional directory listings for Centrex stations may be provided to the customer at the rate established in Section 19 of this Product Guide. Directory listings will not be provided for telephone numbers in reserve.

Customers with 40 stations and above may purchase combinations of feature packages. i.e., X Package 1000s and X Package 2000s. The single customer group Nonrecurring Charge of the higher feature package will apply.

A customer group charge will apply on the initial order and when a change of feature package is requested by the customer or when an order exceeds the installed customer group capacity. A customer group charge will not apply to subsequent primary station line additions.

Centrex Service is offered from this Product Guide in increments intended to meet end user capacity requirements. Rates listed in the RATES Section of this Product Guide are applicable for Centrex Service based on individual end user customer configuration.

CENTREX SERVICE

I. SPECIAL CONDITIONS (Continued)

B. CENTREX FEATURE PACKAGE LIST

<u>Centrex Features</u>	<u>Package 1000</u>	<u>Package 2000</u>	<u>Package 3000</u>
Call Forwarding	X	X	X
Call Hold	X	X	X
Call Pickup	X	X	X
Call Transfer	X	X	X
Call Waiting	X	X	X
Conferencing (Three Way Calling)	X	X	X
Distinctive Ringing	X	X	X
Speed Dialing (6 or 8 Numbers)	X	X	X
Station Hunting	X	X	X
Station-to-Station Dialing	X	X	X
Automatic Call Back (Camp On)		X	X
Call Park		X	X
Last Number Redial		X	X
Toll Restriction		X	X
ARS/FRS			X
Remote Access to Features			X
Message Detail Recording			X

(T)  
 |  
 (T)

C. FEATURES

The following features are available in Feature Packages 1000, 2000, and 3000. Features may not be substituted to, deleted from, or transferred between packages. Feature definitions:

1. Call Forwarding - allows incoming calls to a Centrex station to be automatically forwarded to another telephone number. There are three variations of Call Forwarding: (1) forward all calls, (2) forward when busy, or (3) forward when no answer. Forwarding for hunt groups is available for the above three options.
2. Call Hold - enables a station, engaged in a call, to set the call into a holding condition completely freeing the station to place a call, receive a call, and or use other Centrex services. One call per station line can be held at a time.
3. Call Pickup - allows one party to dial a code and pickup another party's ringing telephone thus connecting the calling party with the party that dialed the code. The pickup can be directed to any person within a call pickup group or to a specific station number.

Effective: April 1, 2016

---

CENTREX SERVICE

I. SPECIAL CONDITIONS (Continued)

C. FEATURES (Continued)

4. Call Transfer

Station-controlled transfer of calls to other stations of the same Centrex system. This feature also allows a station user to hold a call and originate a call to another station inside the system for consultation and add-on purposes. Only one station outside the Centrex system may be involved in the transfer arrangement. Station transfer and add-on connections are subject to transmission limitations.

Call Transfer – Individual – All Calls: Consultation Hold – All Calls, and Three-Way Calling – All Calls. A station user may hold any established call by flashing the switchhook, and on the same line originate a call to another telephone in or outside the Centrex system for private consultation. After the called person's answer or consultation, the station user can by flashing the switchhook a second time, either return to the original call that was held, after the second station user hangs up; or add the second station user to the original call (Three-Way Calling).

The station user can also transfer the second station user to the original call by hanging-up after utilizing the Consultation Hold-All Calls and/or the Three-Way Calling feature. Only one party may be outside the Centrex system on the call transfer.

Calls cannot be transferred to high risk or international destinations. The capacity to transfer calls to high risk destinations (including international calls) is provided by the optional feature as defined in Special Conditions d.3. Unrestricted Call Transfer.

Unrestricted Call Transfer

This allows subscribers of Call Transfer – All Calls the ability to override the fraud prevention feature inherent to Call Transfer – All Calls. It enables the subscriber to transfer calls to all direct dialed numbers at international and other high risk destinations.

An Unrestricted Call Transfer Agreement form must be signed by the customer and be on file.

Customer assumes all liability for toll fraud resulting from overriding the fraud prevention feature. Charges between the originating location and the DID-DOD transfer equipped station will be billed to the originating caller. The transferring Centrex station will be responsible for applicable charge from the Centrex station to the telephone number that answers the transferred call. All local, measured unit, zone units, and toll charges are applicable in accordance with this Product Guide and other Company Tariffs.

5. Call Waiting – an incoming call encountering a busy station receives audible ringing. The called busy station receives a call waiting tone and may then acknowledge the incoming caller, place the existing caller on hold, then alternate between callers or abandon one of the calls. Call Waiting has three configurations depending on the station user's needs: (1) CW –Incoming only, (2) CW – Originating, or (3) CW – Terminating.
6. Conferencing (Three-Way Calling) – allows a station to conduct the following configurations: (1) two other system stations, (2) one system station and one outside party, or (3) two outside parties. If the originating party disconnects, the Call Transfer feature will be invoked. (See Special Conditions C.4. above). In some instances, this may cause the call to be terminated.



Effective: April 1, 2016

---

CENTREX SERVICE

I. SPECIAL CONDITIONS (Continued)

C. FEATURES (Continued)

7. Distinctive Ringing – provides for distinctive different rings at the called station to distinguish between a direct inward dialed (DID) call and an intra-group call.
8. Speed Dialing (6-8) – allows each station user to place calls to its own previously designated electronic list of either 6 or 8 (depending on switch type) frequently dialed numbers.
9. Station Hunting – when the called station is busy, allows for the routing of the incoming call to an idle station in a prearranged hunt group.
10. Station-to-Station Dialing - allows a station user to dial another station within the same Centrex customer group using three to seven digits of the telephone number or intercom numbering plan.

The following features, in addition to the ones defined above, are available from Feature Packages 2000 and 3000:

11. Automatic Call Back (Camp On) - allows a station reaching a busy condition on an internal call to be notified when that busy station becomes available and to be placed automatically in a "call back" mode. After invoking the Camp On feature, the station may make and receive calls, or make general use of the system. At the moment both stations are free, Centrex will call the originating station first and when the user answers, the system will call the camped-on station.
12. Call Park - allows a station engaged in a call to place the call into a holding condition for access from another station in the system. (Call Park differs from Call Hold in that the call placed on hold is associated with an index code, or in some systems a station number, and does not standby for access by the station which placed the call on hold. Call Park allows any station to dial a Call Park retrieval code to be connected to the held call.) Call Park is offered from digital switches only.
13. Last Number Redial - allows the user to redial his/her last manually dialed number by depressing a single key.
14. Toll Restriction - disallows the dialing of long distance calls. The Company may provide predetermined toll restriction packages (i.e., restriction to local area code, restriction to Local LATA, etc.) which will restrict dialing to specific areas.

The following features, in addition to the ones defined above, are available from Feature Package 3000:

15. Automatic Route Selection/Flexible Route Selection (ARS/FRS) -automatically selects the most economical route to a destination.

Effective: April 1, 2016

---

CENTREX SERVICE

I. SPECIAL CONDITIONS (Continued)

C. FEATURES (Continued)

Feature Package 3000 includes 3-digit routing to selectively route calls over two or more routes with a capacity of 8 patterns per customer group.

16. Remote Access to Features - allows a user who is away from the office to dial directly into the Centrex system (without attendant intervention) and gain complete access to Centrex system facilities and outgoing trunk circuits. The caller is required to have a "security access" code.
17. Message Detail Recording - provides a record to the customer of originating messages routed over tie lines and private lines under certain conditions, FX, WATS, CCSA, and/or exchange and toll network. It is not a source for billing detail.

It includes the calling station number, called number, date, time of day, duration of call and type of facility routing.

Call attempts over some FX facilities, whether completed or not, will be recorded. Message detail will not be provided for intra-Centrex customer group.

Message detail for a call routed over a WATS trunk will include the called number, date, time of day, duration of call, type of facility routing and may include the calling station number.

The following features are available in the Centrex CLASS package. The customer must also subscribe to at least Feature Package Series 1000 to have Centrex CLASS.

18. Automatic Busy Redial - is an arrangement which permits the customer to redial automatically the last number dialed. If the called line is found to be busy, a 30-minute queuing process begins. The customer is then given an indication that the network will attempt to set up the call when the called line is idle. The network periodically tests the busy/idle status of the called line until both lines are found idle, the customer cancels the request, or the queuing process expires. If both lines are found to be idle, the calling party is alerted with a distinctive ring signifying that the call can now be completed.
19. Automatic Call Return (\*69) - allows a customer to return the last incoming call when the service is activated by dialing \*69.

This feature is offered on a monthly subscription or per activation basis.

Per activation customers are charged upon dialing \*69, regardless of whether the call is completed to the calling party. The customer is charged for any call placed by means of this service.

Custom Local Area Signaling Service (CLASS) features are applicable to calls placed to/from compatible central offices or within a compatible central office offering the service. These services are offered based on information stored within the switch or provided to the switch through call setup signaling and are subject to limitations associated with the availability and content of that information.

Effective: April 1, 2016

---

CENTREX SERVICE

I. SPECIAL CONDITIONS (Continued)

C. FEATURES (Continued)

The following features are available in the Centrex CLASS package. The customer must also subscribe to at least Feature Package Series 1000 to have Centrex CLASS. (Continued)

20. Call Block - allows a customer to block incoming calls from a maximum of 12 telephone numbers. The customer can also block incoming calls placed from the last calling number even if the number is unknown to the customer.
21. Do Not Disturb - allows a customer to select up to 12 telephone numbers from which calls are to be received. All other calls are intercepted and routed to a recorded announcement that informs the caller that the customer is not accepting calls. Calls from numbers outside the specified exchanges will ring normally.
22. Select Call Forwarding - is an arrangement which permits a customer to pre-specify telephone numbers (maximum of 12) from which incoming calls are to be forwarded. During the period that Select Call Forwarding is activated, only calls from the prespecified numbers will be forwarded.
23. Special Call Waiting - allows a customer to choose up to 12 numbers which can activate Call Waiting. Incoming calls placed from numbers not selected by the customer receive busy signals when the customer's line is busy. Customers may not subscribe to Call Waiting and Special Call Waiting on the same line.

---

CENTREX SERVICE

I. SPECIAL CONDITIONS (Continued)

D. OPTIONAL FEATURE DEFINITIONS

Paging Interface - allows Centrex stations and the attendant(s) to access customer provided loudspeaker paging equipment located throughout the customer's premises. Paging Interface does not provide facility path from paging source.

Customer Moves and Changes (CMAC) - CMAC provides customers with the ability to prepare, schedule, and implement feature changes and configurations from a computer terminal located on the customer's premises.

Functions

The customer controls the following functions:

1. Service Option Information Changes
  - (a) Line Restriction Status
  - (b) Facility Restriction Level Assignment
  - (c) Call Pick-Up Group
  - (d) Call Forwarding Number
  - (e) Authorization Code Assignment
  - (f) Button Features
2. Activation/Deactivation of Features
3. Telephone Number Swaps
4. Reports (Queries and Tallies)

Function Definitions

1. Service Option Information Changes
  - (a) Line Restriction Status - The customer can restrict telephone numbers from all Service Option Information Changes. If changes are desired at a later time, the customer can remove the restriction.
  - (b) Facility Restriction Level Assignment - The customer can change the Facility Restriction Level (a permission level assigned to define calling privileges) associated with both facilities and station users.
  - (c) Call-Pickup Group - The customer can establish a call-pickup group and add or delete members from an existing call-pickup group.
  - (d) Call Forwarding Number - The customer can change the number that a station user forwards calls to.
  - (e) Authorization Code Assignment - An authorization code is a number associated with a specific person rather than a specific telephone number. The customer can activate, change, or deactivate authorization codes. The customer can also display the features associated with the authorization code for a particular user.
  - (f) Button Features - The buttons on a multi-button station set can either activate features or enable call appearances (specific telephone numbers assigned to buttons). The customer can manipulate the features assigned to the buttons.

Effective: April 1, 2016

---

CENTREX SERVICE

I. SPECIAL CONDITIONS (Continued)

D. OPTIONAL FEATURE DEFINITIONS (Continued)

Customer Moves and Changes (CMAC) (Continued)

Function Definitions (Continued)

2. Activate/Deactivate Features - The customer can either add a feature to a telephone number that does not have it, or take a feature off a telephone number that does. This function is limited to the features included in the feature packages subscribed to by the customer.
3. Swap Telephone Numbers - The customer can swap telephone number assignments among lines within a group.
4. Reports (Queries and Tallies) - Customers can run reports that show the status of existing and requested feature changes (feature queries) and the total number of stations with the features that they have (feature tallies).

The customer can be provided with a set of standard reports or can request that the Company customize the standard report formats to the customer's specifications.

The customer can run query or tally reports as a function by itself or may choose to perform other system functions once the report request is made. This feature of the report function keeps customers from having to wait on-line for reports to be processed.

Direct Digital Interface (DDI) - provides a trunk side connection to a High Capacity Digital Channel within the Company's central office. Each DDI is equivalent to 24 derived voice grade circuits. DDI tandem is available only where facilities and operating conditions permit.

Conferencing (6 to 8) - allows a station user or attendant to form a conference with either six or eight parties, depending on switch type, including other stations and/or parties reached over trunks.

Music on Hold Interface - provides access to a customer provided music source for use with Call Hold, Call Park, Consultation Hold, Call Transfer, Three Way Calling, Off-Hook Queuing and ACD/UCD. Music on Hold Interface does not provide facility path from music source.

Automatic Route Selection/Flexible Route Selection (ARS/FRS) - automatically selects the most economical route to a destination. The customer controls and programs a predetermined routing pattern for WATS, Foreign Exchange, DDD trunks, etc.

Automatic Route Selection/Flexible Route Selection (Upgrade) - customers wishing to increase their capacity to either 32 or 64 patterns may do so with this option.

ISDN-PRI Centrex Access - provides the interface between ISDN-PRI Tie Channel Services and the Centrex System. ISDN-PRI Access and Tie Channel Service are required for this application. PRIs that only require Tie Channel intercom functionality do not require ISDN-PRI VOIP Centrex Access charges.

Effective: March 1, 2018

---

CENTREX SERVICE

I. SPECIAL CONDITIONS (Continued)

D. OPTIONAL FEATURE DEFINITIONS (Continued)

ISDN-PRI Voice over Internet Protocol (VOIP) Centrex Access - is augmented with Centrex features to integrate Centrex service with Voice over the Internet Protocol applications. ISDN-PRI Access and Tie Channel Service are required for this application.

Single Digit Dialing - permits a preselected station line of the customer group or other internal facilities of the customer to be called from another station by use of a single digit code. This service is intended primarily for hotels, motels, and hospitals for guest or patient use.

Speed Dialing (30) - allows each station user to place calls to a previously designated electronic group list of up to 30 (depending on switch type) frequently dialed numbers.

Auto/Universal Call Distribution (ACD/UCD) - This arrangement enables incoming calls to be directed to and distributed evenly among a select group of station lines. Also, see Special Condition D, Termination Arrangements following.

Trunk Queuing - allows a call to wait for a facility in a private facility group to become idle on a first come-first served basis. This feature may be invoked after a customer is unsuccessful in trying to reach a called party.

Attendant Position Interface - service features are not available when attendant's positions are provided by the customer and also may not be available from some switching equipment. Attendant Position Interface does not provide facility path from central office to customer's location.

1. Attendant Camp-On - allows incoming calls which the attendant attempts to complete to a busy station to be held waiting with audible indication to the busy station and then to be automatically connected when the called station is available.

(D)  
(D)

2. Conference Arrangement (Attendant Control) - allows the attendant to establish a conference between stations and/or outside parties.

(T)

3. Night Answer Any Station - allows primary station with the Centrex customer group to dial access to answer incoming calls when a Night Service is activated at the attendant position.

(T)

Effective: April 1, 2016

---

CENTREX SERVICE

I. SPECIAL CONDITIONS (Continued)

D. OPTIONAL FEATURE DEFINITIONS (Continued)

Termination Arrangements

1. Private line terminals, which may include access lines (CCSA), tie lines and interexchange private lines, arranged for termination in Centrex switching equipment, may be dial accessed by stations and attendants for calls made only within a Centrex customer group connected by the lines so terminated, and may have access to stations only, except when arranged as a tandem private line terminal.
2. Tandem private line terminals provide for the same termination arrangement as in D.1., above and the line so terminated may have dial access. For intra-Centrex customer group calls, tandem dialed calls to tandem private line terminal-connected Centrex customer group, local and toll network trunks, dial "0" attendant facilities, access lines (CCSA), and other services and features utilizing discrete dialing access codes.
3. Tandem private line automatic terminals, which may include tie lines and interexchange private lines arranged for termination in a Centrex customer group, may be dial accessed by stations and attendants, and the calls over the lines so terminated will be automatically routed to the attendant or a termination arrangement in the Centrex customer group.
4. Any change of a dial access level to reach a tie line, interexchange private line, local and toll network trunk, WATS <sup>1</sup> line, attendant, etc., of an existing tandem and/or private line will be at the applicable nonrecurring charge under the rates above.
5. The Company shall not be responsible for the through transmission of signals or supervision when private lines or tandem private line terminals, including automatic, are arranged for termination in a Centrex customer group.
6. Foreign Exchange trunk lines arranged for termination in a Centrex customer group may be dial accessed by stations, attendants, and tandem private line terminals for outgoing calls.
7. Special services terminals arranged for termination in a Centrex customer group may provide discrete dial access to customer-provided paging, dial dictation or station equipment by stations, attendants and tandem private line terminals.

Meet Me Conference - allows members of a Basic Business Group to arrange for Meet Me Conference by dialing a predetermined access code at the time which the conference is scheduled.

Recorded Announcement - allows incoming calls to a multiline hunt group to activate a delay announcement where answer supervision is returned to the calling party and first announcement is connected. Customer may specify wording of announcement. This feature can also be arranged for use with ACD/UCD and trunk queuing. See also Special Condition j., above.

Dormitory Service - is a Centrex feature package which includes the following standard Centrex features: Call Forwarding, Call Waiting, Conferencing (Three-Way Calling), and Station-to-Station Dialing.

Proprietary Interface - is a digital network interface used to integrate digital terminal equipment with GTD-5 or DMS-100 central office switching equipment. Each digital telephone connected to a Centrex station line requires a Proprietary Interface.

Effective: April 1, 2016

---

CENTREX SERVICE

I. SPECIAL CONDITIONS (Continued)

D. OPTIONAL FEATURE DEFINITIONS (Continued)

Pseudo Number - is a software number which has the characteristics of a basic exchange access line. The Pseudo Number function operates in conjunction with Proprietary Interface described in "Recorded Announcement" preceding. Package rates will apply for each Pseudo Number, in addition to Pseudo Number rates listed in II. Rates and Charges A.20.

Instant Call Accounting (ICA) - Provides the customer with records of calls originating from Centrex stations. Each call record will contain the date, time, and duration of the call, the calling station number, facility used, and the number that was called.

Dedicated ICA - The customer's call records are continually transmitted from the central office to the customer's premises equipment through a dedicated private line connection. Special Access Service in the Facilities for Intrastate Access Tariff C-1 should be used to determine the appropriate provisioning and the applicable rates and charges for the required dedicated data channel between the serving central office and the customer premises equipment.

Dial-Up ICA - The customer, using CPE, initiates a download request to the central office processor in order to retrieve the call records. The records are transmitted immediately back to the customer's premises equipment upon completion of the request.

Call Trace - allows a customer to automatically activate a trace record of the last incoming call. By activating the Call Trace feature, the customer automatically authorizes the Company to store the results of any and all traces initiated by the customer in the Company's switching office. The result of such traces will be released to the appropriate law enforcement agency only upon such a further request by the customer. The trace record will provide only the incoming telephone number and no way identifies the person(s) actually placing the calls(s). The customer acknowledges their understanding that under no circumstances will trace results be provided directly to the customer. The customer must contact the Company within ten days after activating a call trace or the trace record will automatically be deleted from the system.

Priority Call - allows a customer to program up to 12 telephone numbers of selected callers enabling the customer to distinguish certain incoming calls from all others by a distinctive ring tone. If a customer also subscribes to Call Waiting, calls from the selected numbers will be distinguished by a special Call Waiting tone.

Caller ID - Number Only - provides for the display of an incoming telephone number on a customer provided display device attached to the customer's telephone line or on a telephone or answering machine with a built-in display screen. Service can be provided to customers subscribing to rotary service. The Caller ID - Number Only feature will forward the calling number from the appropriately equipped central office to the customer provided display device. The Company will forward all non-blocked telephone numbers (including Nonpublished and Nonlisted telephone numbers) subject to technical limitations. Call Waiting ID may be implemented at no additional charge. In order for Call Waiting ID to work, Call Waiting in Feature Package 1000 must be activated along with this service. (See Section 6 of this Product Guide for feature description.)

All customer provided equipment used to interface with Caller ID - Number Only must be connected in accordance with the provisions of the Federal Communications Commission's Registration program. Any intent to sell name(s) and/or number(s) gathered as a result of Caller ID - Number Only is prohibited. This service is available only where facilities and conditions permit.



Effective: April 1, 2016

---

CENTREX SERVICE

I. SPECIAL CONDITIONS (Continued)

D. OPTIONAL FEATURE DEFINITIONS (Continued)

Selective Blocking - Per Call - provides free per-call blocking in exchanges where Caller ID is offered by the Company. Customers may prevent the delivery of their name and/or telephone number to the called party on a call by call basis. This is accomplished on a per call basis when the customer dials the Selective Blocking - Per Call activation code prior to placing the call. Selective Blocking does not prevent delivery of name and/or telephone numbers when services that utilize Automatic Number Identification (ANI) are called (e.g., 0+, 0-, 700/800/900 and 911 Services).

Complete Blocking - Per Line - provides free per-line blocking in exchanges where Caller ID is offered by the Company. The service, when activated by the Company, prevents the delivery of the customer's name and/or telephone number to the called party. A Complete Blocking - Per Line customer has the option of deactivating the blocking feature and forwarding their name and/or telephone number on a per call basis by dialing a code prior to placing the call. Complete Blocking does not prevent delivery of name and/or telephone numbers when services that utilize Automatic Number Identification (ANI) are called (e.g., 0+, 0-, 700/800/900 and 911 Services).

Caller ID provides for the display of an incoming name and telephone number on a customer provided display device attached to the customer's telephone line or on a telephone or answering machine with a built-in display screen. Service can be provided to customers subscribing to rotary service. The Caller ID feature will forward the calling name and number from the appropriately equipped central office to the customer provided display device, typically by the second ring. The Company will forward non-blocked names and telephone numbers (including nonpublished and nonlisted telephone numbers), subject to limitations such as those described below. Call Waiting ID may be implemented at no additional charge. In order for Call Waiting ID to work, Call Waiting in Feature Package 1000 must be activated along with this service. (See Section 6 of this Product Guide for feature description.)

The name and telephone number of the caller may not be displayed for every incoming call. "Out of Area," "Unavailable," the calling party's state name, or a similar message may appear for certain calls, including (i) calls made through certain networks, (ii) operator-assisted calls, calls from toll-free numbers, calling card calls, and international calls, (iii) when phone number or caller name information is not made available to Frontier, (iv) for certain telephone numbers for which Frontier does not purchase Caller ID information, and (v) for other technical reasons. In addition, "Private," "Anonymous" or a similar message may appear when the caller has blocked caller identification information.

All customer provided equipment used to interface with Caller ID must be connected in accordance with the provisions of the Federal Communications Commission's Registration program. Any intent to sell name(s) and/or number(s) gathered as a result of Caller ID service is prohibited. This service is available only where facilities and conditions permit.

Effective: April 1, 2016

---

CENTREX SERVICE

I. SPECIAL CONDITIONS (Continued)

D. OPTIONAL FEATURE DEFINITIONS (Continued)

Anonymous Call Block<sup>1</sup> - allows a customer to reject calls from callers who have activated a blocking option in order to prevent the display of their telephone number. Anonymous Call Block is activated or deactivated by dialing a preassigned code.

Assigned Centrex Telephone Numbers - Customers are required to keep 50% or more of their assigned telephone numbers working, in order to retain them. The Company will notify customers annually if the quantity of working numbers drops below 50% of their assigned numbers, so that action can be initiated by the customer to increase their number of assigned numbers working, or by Frontier to reclaim numbers. Telephone numbers working periodically for regular intervals of time, such as those assigned to student residences, are "working at all times" to the extent that they work for a minimum of 90 non-consecutive days during each calendar year in which they are assigned to the customer.

Station Message Detail Recording (SMDR)

General - Station Message Detail Recording (SMDR) is an optional feature of Centrex Service that provides a record of calls originating from Centrex Service station lines to locations outside of the Centrex Service system. Facility groups may also be designated as requiring originating and terminating records. The SMDR record includes the following information:

The Centrex Service line number of the incoming facility group which originated the call or the originating station number:

the called telephone number;  
the date, time and duration of the call; and  
the facility type used for routing the call.

Authorization codes, if ordered by the customer, can be included in the record at the discretion of the station user. The applicable rates and charges for authorization codes can be found in this Section, II. Rates and Charges A.18.c.

<sup>1</sup> Applicable charges for Anonymous Call Block from Section 7 of this Product Guide will apply.

Effective: April 1, 2016

---

CENTREX SERVICE

I. SPECIAL CONDITIONS (Continued)

D. OPTIONAL FEATURE DEFINITIONS (Continued)

Station Message Detail Recording (SMDR) (Continued)

SMDR records are provided to the customer by one of the following methods:

Dedicated Access - SMDR may also be provisioned via Dedicated Access (to the customer's location). The call records are transmitted to the customer, via a dedicated voice grade circuit, from the central office to the customer location. This optional feature requires the customer to also subscribe to a voice grade circuit. The rates and charges for the dedicated access are provided on an Individual Case Basis (ICB).

Dial-Up Access - The customer dials into a centralized location to retrieve the call records when desired. Call records are stored for a maximum of 10 days.

Internet Access - The call records are sent by electronic mail (email) to the customer via the Internet.

Conditions

SMDR is available only from capable central office switches where facilities permit.

SMDR is not a substitute for billing detail.

Local call records are provided only where available.

The customer must designate all station lines in a customer group and/or facility groups on which SMDR is to be provided.

Modems, collection devices, computer equipment and software are the responsibility of the customer and are not provided as part of this service.

Unlimited Local and Toll Usage for Business Feature Package Two B - Centrex customers who subscribe to Unlimited Local and Toll Usage for Business <sup>1</sup> are eligible to also subscribe on the same line(s) to either or both of the following services offered in Feature Package Two B:

Caller ID and/or Voice Messaging

Unlimited Local and Toll Usage for Business Feature Package Three - Centrex customers who subscribe to Unlimited Local and Toll Usage for Business <sup>1</sup> are eligible to also subscribe on the same line(s) to either or both of the following services offered in Feature Package Three:

Caller ID and/or One Point Voice Mail (OPVM)

<sup>1</sup> See Section 8 of this Product Guide for the rates and descriptions of these services.

Effective: April 1, 2016

---

CENTREX SERVICE

I. SPECIAL CONDITIONS (Continued)

E. DIRECT INWARD DIALING (DID)

Direct Inward Dialing (DID) allows incoming calls from the exchange and toll network to be completed directly to a primary station. Direct Outward Dialing (DOD) allows outgoing calls to the exchange and toll network to be completed directly from a primary station by dialing an access code.

F. DORMITORY SERVICE

A customer may not combine flat and measured rate service furnished in this Section except dormitory flat rate service which may be furnished concurrently with measured rate Centrex service.

Dormitory lines furnished in this Section require the Centrex rates and charges shown in II. Rates and Charges A.17.

1. Dormitory Feature Package includes the following features:
  - (a) Call Forwarding
  - (b) Call Waiting
  - (c) Conferencing (Three Way Calling)
  - (d) Station to Station Dialing
2. The lines are those provided in the General Exchange Tariff, Schedule No. A-1 for individual residential service. New service, additions, in place connection, move and changes are subject to charges in Section 3 of this Product Guide.
3. The lines will be furnished to schools, colleges, and universities who are customers to Centrex primary lines and may be installed only in the living quarters of residence halls, dormitories, faculty or other employee residences and other similar living quarters, which are owned or leased and operated by a school, college or university and the use of such stations is in accordance with that for residence service as shown in the General Exchange Tariff, Schedule No. A-1.
4. The school, college or university is responsible for the billing and collecting of toll and local message charges and the payment of all other rates and charges associated with such stations.
5. Local message units and Zone Usage Measurement (ZUM) units apply as set forth in Section 5 of this Product Guide, or message toll charges as set forth in in Section 28 of this Product Guide.
6. Each dormitory station can have a listing in the alphabetical section of the local directory at the residence additional listing rate from in Section 21 of this Product Guide.

Effective: April 1, 2016

---

CENTREX SERVICE

I. SPECIAL CONDITIONS (Continued)

G. AUTOMATIC ROUTE SELECTION (ARS)/FLEXIBLE ROUTE SELECTION (FRS)

ARS/FRS automatically directs outgoing station calls to dedicated trunk groups which have been arranged in a first through fourth choice order to provide most preferred available route. Local exchange facilities may be used to complete a call which terminates outside the local service area if the other pre-selected trunk groups are busy, and will be used to complete calls within the local service area.

The customer controls and programs a predetermined routing pattern and will inform the Company as to the trunk type (WATS, Foreign Exchange, DDD, Digital High Capacity trunks, etc.).

H. MESSAGE DETAIL RECORDING (MDR)

Message Detail Recording (MDR) provides a record to the customer of originating messages routed over tie lines and private lines under certain conditions, FX, WATS, CCSA and/or the exchange and toll network. This is not a source for billing detail.

1. Includes the calling station number, called number, date, time of day, duration of call, and type of facility routing.
2. Message Detail for calls routed over a WATS trunk will include the called number, date, time of day, duration of call, type of facility routing, and may include the calling station number.
3. Call attempts over some FX facilities, whether completed or not will be recorded. Message detail will not be provided for intra-Centrex customer group.
4. Message Detail Reporting is furnished at the rate of \$0.30 per line.

I. AUTHORIZATION CODES

Used to override the calling restrictions placed on a particular line.

J. CODE CALL ACCESS

Provides access to customer provided code calling signaling devices.

K. DICTION ACCESS AND CONTROL

Provides for station access to customer provided dictation equipment.

L. PREFERENTIAL HUNTING

Assigns hunting for an individual group of hunt group members to a pilot number of another circular hunt group. This requires one or more hunt groups.

Effective: April 1, 2016

---

CENTREX SERVICE

I. SPECIAL CONDITIONS (Continued)

M. PRIORITY QUEUING

Provides two levels of priority in the handling of queued calls: high priority and low priority. This requires off hook queuing.

N. STOP HUNT

Uses a code to stop the hunting process when a particular line is reached in a hunting sequence. This requires one or more hunt groups and may require additional hardware.

O. TERMINAL MAKE BUSY

Allows a station or group of stations to appear busy to incoming calls. This requires one or more hunt groups.

P. TIME OF DAY ROUTING

Provides for route selection based on the most economical path (as determined by the customer) for a particular time-of-day or day-of-week.

Q. EXCHANGE AND TOLL MESSAGE DIVERTING

Allows the customer to establish a toll diverting pattern by pre-selecting approved NXX and/or NPA codes while restricting calls to all other locations.

R. DIRECT CONNECT SERVICE

Allows a Centrex station line to automatically place a call to a preassigned called number when the station user goes off-hook. A station with direct connect service will receive incoming calls normally.

---

CENTREX SERVICE

I. SPECIAL CONDITIONS (Continued)

S. INSTANT CALL ACCOUNTING (ICA)

1. ICA is provided either as a dedicated connection or as a dial up connection and will be offered per Centrex customer group.
2. Each call record will contain the date, time, and duration of the call, the calling station number, facility used, and the number that was called.
3. Records will be provided for calls originated from Centrex stations and include billable toll, local measured, and calls made over private facilities (FX, WATS, CCSA).
4. Records will NOT be provided for incoming calls, station-to-station (intercom) calls, or local calls (except in measured service areas).
5. The records produced by this service are not represented to be a provision of billing detail.  
  
f. Customers can choose data transmission speeds ranging from 1200 bps to 9600 bps. Customer's CPE must be capable of automatically dropping transmission speeds until an achievable speed is reached.
6. Call accounting records will be provided on terminal equipment located at the customer's location.
7. Customers will be required to provide compatible CPE to process the call detail records.
8. The Company makes no guarantee and assumes no liability associated with the customer's receipt of call detail records if the customer-provided CPE does not meet Frontier's compatibility requirements. The data will not be stored by the Company after it is transmitted to the customer. Once the data is transmitted, it will no longer be available.
9. ICA will be furnished only where facilities are available. Service is offered on a limited basis by specific switching systems within certain geographical areas. Since this service is not offered in all areas, it is important to verify its availability by contacting your Company Account Representative or Business Office at the telephone number listed in your telephone directory under the heading "WHERE TO REACH FRONTIER", for Installation/Service.
10. Dedicated ICA
  - (a) Call records are continually transmitted to the customer's premises.
  - (b) A four-wire Special Access Line from the Facilities for Intrastate Access Tariff C-1 is required for the dedicated data link.
  - (c) A customer-provided dial modem is required.
11. Dial-Up ICA
  - (a) The customer initiates a call to retrieve call records.
  - (b) A 1MB or Centrex line is required.
  - (c) A customer-provided dial modem is required.
  - (d) To prevent the possible risk of lost call records data, Dial-Up customers need to access their call records at least every seven days.

Effective: April 1, 2016

---

CENTREX SERVICE

I. SPECIAL CONDITIONS (Continued)

T. CUSTOMER MOVES AND CHANGES (CMAC)

1. Customer Moves and Changes (CMAC) is available to either existing or new Centrex customers.
2. Customers with compatible customer premises equipment may access CMAC from any new or existing local exchange access line (subject to the appropriate rates and charges in in Section 4 of this Product Guide).
3. Customers will have 24-hour dial-up access to the CMAC system except when restricted during maintenance windows. On occasion, customers may receive a busy condition.
4. Customers will have up to two hours per dial-in session on the CMAC system. A warning tone will sound as the two-hour limit approaches. During the dial-in session, the Company will discontinue the transmission after a period of inactivity.
5. Some of the lines in a customer's Centrex system cannot or should not be rearranged through CMAC (for example, some groups of Centrex lines that have been previously arranged as multi-line hunt groups). Changes to these Company-specified lines will be made through the Company's existing service order procedure.
6. All normal or emergency functions of the central office switch processor will have priority over execution of CMAC requests. The Company assumes no responsibility for change requests delayed by priority central office switch processor functions.
7. The Company reserves the right to inhibit CMAC service in the event of a service-affecting condition to the central office or affiliated operating support system.
8. CMAC will be furnished only where facilities are available. Service is offered on a limited basis by specific switching systems within certain geographical areas. Since this service is not offered in all areas, it is important to verify its availability by contacting your Company Account Representative or Business Office at the telephone number listed in your telephone directory under the heading "WHERE TO REACH FRONTIER", for Installation/Service.



Effective: April 1, 2016

---

CENTREX SERVICE

I. SPECIAL CONDITIONS (Continued)

U. ASSUME DIAL "9"

This service eliminates the need for a subscriber to dial the digit "9" before accessing telephone numbers outside of his Centrex customer group. The term "customer group", when used in connection with this service, is defined as a group of lines sharing identical intercom and network access dialing patterns. Each group of stations having different dialing patterns will be considered as separate customer groups for purposes of determining appropriate rates and charges.

1. Individual customer requirements may require the provisioning of additional Centrex features (Toll Restriction, Flexible Route Selection, Automatic Route Selection upgrades, etc.) in connection with this service.
2. This service is available where facilities and conditions permit.
3. The Company reserves the right to deny or discontinue Assume Dial "9" service when technology, administration, and/or future code conflicts are encountered. In such cases, the Company will notify the customer 30 days prior to the discontinuation of service.
4. Assume Dial "9" service may cause delays in call processing or misdirected calls.

V. DISCOUNT PRICING PLANS (DPP)

1. Customers who purchase Centrex Service (Centrex line, with Discounted IntraLATA Toll, or Feature Packages) are eligible for one of three Discount Pricing Plans (DPP). These DPPs are for periods of 12 Months, 36 Months, or 60 Months (60 Month DPP is for customers with more than 50 lines) and allow the customer to receive discounted rates for purchasing a term discount pricing plan.
2. Before the expiration of a DPP period, a customer may purchase a DPP for a new term period with the same or longer time period than the current term. When the new DPP becomes effective, the customer is charged the new DPP rate for the life of the DPP. The original term period and rates are no longer effective.
3. Customers may aggregate all locations statewide to calculate the discount for their Discount Pricing Plans (DPPs).
4. All Centrex lines in the same Centrex customer group must be covered by the same Discount Pricing Plan.
5. If available, and subject to central office capacity, as determined by the Company, additional lines may be added at the discounted monthly rates in effect at the time the Discount Plan agreement was executed.
6. Feature packages purchased in conjunction with a Centrex line DPP must be for the same term length as the station line.

Effective: April 1, 2016

---

CENTREX SERVICE

I. SPECIAL CONDITIONS (Continued)

V. DISCOUNT PRICING PLANS (DPP) (Continued)

7. Customers who terminate the agreed upon DPP before the expiration date, will be assessed a Termination Liability as stated in Special Condition W.1., following.

Effective September 14, 2007, new or renewing customers who, after the first 30 days, partially disconnect service, will be charged termination liability on the disconnected lines as stated in Special Condition W.2., following.

8. Customers subscribing to the Discount Pricing Plan may relocate a Centrex system to a different premises, at the applicable installation charges, served from the same central office or a different central office without penalty except as stated in Special Condition W., Termination Liability, provided central office facilities and operating conditions permit. All terms and conditions of the agreed upon Discount Pricing Plan remain in effect for the remainder of the term.
9. A IntraLATA Toll minimum per Centrex line will be required. Monthly, the Company will true-up the actual toll usage. If the amount is less than the total Centrex lines multiplied by the per line minimum, the customer will be billed for the difference. The customer is also liable for their per line minimum should the service be terminated before the expiration date.
10. Customers must retain IntraLata Toll Service (Intrastate IntraLATA) to receive Centrex Calling Solutions rates. If customer discontinues their IntraLata Toll Service, customer will be changed to Centrex Line Discount Pricing Plan (DPP) rates. All terms and conditions in Section 28 of this Product Guide apply for IntraLata Toll Service.
11. Customers must subscribe to IntraLata Toll Service on all lines in the business group to receive a discount on their toll service. All lines must be the same subscription of Centrex or Centrex with Calling Solutions per Billing Telephone Number (BTN).
12. The IntraLATA Toll discount applies as follows:

Discount Applies to the Following Services

- Direct Dialed and Operator Assisted Calls (includes 0+, 0-, 1+ calls, Third Party and Collect)
- Credit Card Calls <sup>1</sup>

Discount Does Not Apply to the Following Services

- Operator Surcharges
- Wide Area Telephone Service (WATS)
- Mobile Service
- Zone Usage Measurement
- Local Usage Measurement
- Frontier Pay Station
- Lines with Handicap Discount

Effective: April 1, 2016

---

CENTREX SERVICE

I. SPECIAL CONDITIONS (Continued)

W. TERMINATION LIABILITY CHARGE FORMULA

1. Customers who terminate the agreed upon DPP before the expiration date will be assessed termination liability as set forth in Section 2 of this Product Guide.
2. Effective September 14, 2007, new or renewing customers who, after the first 30 days, partially disconnect service, will be charged termination liability on the disconnected lines as follows:
  - (a) Customers with 2 lines in service who disconnect one line will be assessed full termination liability as described in Special Condition W.1., above.
  - (b) Customers with 3 - 4 lines in service who disconnect any lines will be charged termination liability on the disconnected lines per the formula set forth in Section 2 of this Product Guide. Customer must maintain 2 lines to have Centrex Service.
  - (c) Customers with 5 or more lines who disconnect over 20% of the total number of lines in service will be charged termination liability on the disconnected lines per the formula set forth in Section 2, B.IX. Termination Liability of this Product Guide.
3. The following termination liability is applicable to Centrex Calling Solutions IntraLATA toll only:

Centrex Calling Solutions customers shall be required to pay the minimum monthly usage requirements for the number of months remaining in the Discount Pricing Plan as determined by the application of the following formula:

Termination Charge = 25% of the Remainder of the Term Commitment Value  
plus Minimum Monthly Usage Charge (\$5.00 X # of Lines X # of Months Remaining)

Centrex Calling Solutions customers who discontinue Frontier Communications of America, Inc. and keep Centrex Service shall be required to pay the Minimum Monthly Usage requirements for the number of months remaining in the Discount Pricing Plan as determined by the application of the following formula:

Termination Charge = [\$5.00 X (# of Lines X # of Months Remaining)]

The Minimum Monthly Usage Charge will not apply when the customer subscribes to both of the following conditions:

- (a) The customer subscribes to a new Centrex Discount Pricing Plan with a term length equal to or greater than the existing Centrex Calling Solutions term for all Centrex lines in that Centrex system.
- (b) The customer subscribes to Frontier Unlimited Local and Toll Usage for Business <sup>2</sup> on a minimum of one of the new Centrex Discount Pricing Plan lines.

<sup>1</sup> Applicable where a contractual arrangement exists between the Company and card issuer.

<sup>2</sup> See Section 8 of this Product Guide for rates and conditions for Unlimited Local and Toll Usage for Business.

## CENTREX SERVICE

### I. SPECIAL CONDITIONS (Continued)

#### X. CENTREX AUTOMATIC CALL DISTRIBUTION/MANAGEMENT INFORMATION SYSTEM (ACD/MIS)

##### 1. GENERAL

Centrex Automatic Call Distribution (ACD) is a central office based service which allows customers' incoming calls to be equally distributed to available agents. Distribution of the calls are determined by call parameters defined by the customer. ACD also allows the customer to manage fluctuations in call patterns, trunk loading, and answering time frames.

ACD associates directory numbers (DN) with groups of answering positions rather than lines. ACD then provides equitable allocation of the workload by distributing calls to customer agents who have been available for the longest period of time.

Queuing capability of ACD allows specific call types to be directed to designated workgroups. In addition, the fluctuation of incoming calls is lessened by placing callers in queue until an agent is free to take the call. The queue reduces the total number of customer operators needed to handle peak traffic loads by evenly distributing the queued calls.

ACD is used with customer provided electronic or nonelectronic telephone sets. An electronic telephone set is a multibutton telephone set that allows for feature activation. A nonelectronic telephone set requires an agent to dial codes to activate features.

The Management Information System (MIS) is a computer based system that provides detailed call management information by providing a global view of ACD call activities within the customer's call center. The information assists in evaluating traffic patterns, trunk utilization, agent efficiency, and lost calls. At the supervisor level, ACD/MIS provides reports of the real-time status of agents and queues by providing reports for continual analysis of transaction activities. These reports enable the supervisor to immediately modify staffing and/or queuing to accommodate increases and/or decreases in call volumes.

Effective: April 1, 2016

---

CENTREX SERVICE

I. SPECIAL CONDITIONS (Continued)

X. CENTREX AUTOMATIC CALL DISTRIBUTION/MANAGEMENT INFORMATION SYSTEM (ACD/MIS) (Continued)

2. DEFINITIONS

Abandoned Call Clearing - Provides for the removal of a call when a caller abandons either while in an incoming call queue or after the call was presented to the agent position.

ACD Group - A group of agents receiving calls directed to the same incoming call queue. These agents can be in one or more supervisor subgroups served out of the same Central Office.

ACD Overflow of Enqueued Calls - Enhances the existing ACD call-overflow capability by adding new timing thresholds for enqueued calls. Calls enqueued for a predetermined amount of time are routed to a defined overflow queue for appropriate action. When a call has overflowed based on time enqueued, it remains in the original queue and is also routed to the overflow queue.

ACD Multiple Line of Business Codes - Allows handling and tracking of multiple activities for the same call in a customer environment with more than one line of business.

ACD Node - Individual customer ACD group(s) served from the same Company central office.

ACD Secondary Directory Number - Provides for the assignment of a feature access position of one or more secondary directory numbers that are separate from the incoming ACD Directory Numbers. This feature allows agents to receive direct non-ACD incoming calls and to make outgoing calls.

ACD Walkaway/Closed - Allows agents to enter a three digit code to make the line unavailable and identify the reason for unavailability to calls. When the not ready key is activated, the code is then recorded by the Management Information System (MIS). Various customer assigned codes for entry provide data to evaluate productivity, schedule work shifts and determine staffing requirements.

Additional Queue Slots (greater than the number of access positions) - Dedicated time slots used to hold incoming calls in a delayed state until an agent becomes available. One queue slot is required for each call to be held in queue.

Agent Login/Logout - Security to ensure only assigned agents are able to login to an ACD group. Agent Login/Logout includes the partitioning of agent login ID numbers and agent login passwords.

Agent Queue - Provides for even distribution of the calls among agents by routing the call to the agent who has been idle the longest.

Answer Agent - Permits a key to be reserved, at the supervisory position, to be used only for answering calls from agents. When an answer key is pressed, the calling agents' directory number is displayed.

Attendant Console to ACD - Allows attendant consoles to extend or originate calls to ACD directory numbers.

---

CENTREX SERVICE

I. SPECIAL CONDITIONS (Continued)

X. CENTREX AUTOMATIC CALL DISTRIBUTION/MANAGEMENT INFORMATION SYSTEM (ACD/MIS) (Continued)

2. DEFINITIONS (Continued)

Automatic Overflow - Reroutes incoming calls when the maximum number of incoming calls are in queue or the first call in queue has reached the maximum waiting time. The parameters for the maximum number of calls per queue and the maximum waiting time are set by the customer.

Call Agent - Allows the supervisor to directly call an agent without having to dial the agent's secondary directory number.

Call Center Manager - provides call center managers with the ability to monitor and control both their calls and their agents. The functions of Call Center Manager are:

- Real-time display and monitoring of agent and call activity.
- Data collection and storage for historical or real-time report generation.
- Real-time or scheduled call routing control and resource availability control.

Within the same Centrex customer group, the customer may monitor and control multiple ACD groups through a single Call Center Manager MIS Link. The use of an additional MIS Link allows the customer to have multiple supervisory terminals supporting the same Centrex ACD groups.

Call Center Report - automatically sends basic ACD reports to a customer designated fax machine. The structure and parameters of the reports are predefined by the Company and contain statistics relating to agent and group performance. The customer provides the fax machine and appropriate telephone line.

Call Forcing - Increases the speed of ACD call handling by automatically presenting incoming calls to the ACD agents. An agent does not need to press the in-calls key to receive the next call.

Call Transfer with Time - Allows a call that has been answered by an ACD agent and then transferred to another ACD agent group to be queued to the new group's highest priority queue based on the total time of the call (time in queue prior to being answered by the first agent plus the length of "talk time" with first agent.)

Called Name/Number Display - Shows the terminating group name and terminating directory number for calls arriving on the agent's set. This information allows the ACD agent to identify the called ACD group for appropriate call answering and call handling.

Call Source ID - Provides for the display, at the agent's position, of the incoming call facility (for calls from within the same customer's group the agent's extension number is displayed). For calls from other customer groups served by the same ACD node, the calling agent's directory number is displayed.

Call Supervisor - Allows the agent quick access to the supervisor for help or consultation.

Effective: April 1, 2016

---

CENTREX SERVICE

I. SPECIAL CONDITIONS (Continued)

X. CENTREX AUTOMATIC CALL DISTRIBUTION/MANAGEMENT INFORMATION SYSTEM (ACD/MIS) (Continued)

2. DEFINITIONS (Continued)

Controlled Interflow - This feature allows a supervisor to temporarily divert a group's new incoming calls to another group because of a change in business conditions.

Delay Treatment - Allows one of two treatments based on anticipated waiting time; either a ring back or a recorded announcement.

Directory Number - Incoming local access numbers assigned to the customer ACD groups.

Display Agents Summary - Key activated function enables the ACD supervisor, using a Business Set with Display, to quickly check the status of all ACD agent positions within a particular ACD group. The summary shows the number of agents:

- busy on ACD and non-ACD calls,
- waiting for calls (idle),
- not ready to receive calls, and
- not available (agent not logged in or Make Set Busy activated).

Display Queue Status - Allows the supervisor position to monitor the efficiency in which incoming calls are being handled. Activation of Display Queue Status shows the following current information for the corresponding ACD directory number:

- number of staffed agent positions,
- number of calls waiting in the incoming call queue,
- number of calls logically queued against group,
- waiting time (in seconds) of the oldest call in queue.

Distinctive Ringing - This feature enables agents to distinguish ACD calls from non-ACD calls.

Emergency Alerting - Enables the ACD agent to confer immediately with the supervisor. The ACD agent can be provided with an emergency key and the supervisor with an answer-emergency key.

Emergency Alerting Enhanced - Enhances the Emergency Alerting feature by allowing the ACD agent to add both a supervisor and a customer provided recording device to a call simultaneously by pressing a single key.

Emergency Answer - Permits an answer emergency key lamp, at the supervisory position, to flash when an agent activates an emergency key.

Effective: April 1, 2016

---

CENTREX SERVICE

I. SPECIAL CONDITIONS (Continued)

X. CENTREX AUTOMATIC CALL DISTRIBUTION/MANAGEMENT INFORMATION SYSTEM (ACD/MIS) (Continued)

2. DEFINITIONS (Continued)

Emergency Answer Backup - Provides a method for redirecting emergency key calls to another customer designated position when the supervisor position is unavailable.

Forced Agent Availability - Allows the ACD supervisor to deactivate a Not Ready condition on a specific line. This feature is key activated on an individual agent basis.

Incoming Call Queue (equal to the number of agents) - Provides queuing of incoming calls based on order of arrival priority.

Make Set Busy - Blocks ACD and non-ACD calls to the position. This feature can be automatically activated if the ringing timer expires on an ACD call presented to that agent.

MIS Data Stream Interface - Enables a downstream processor to use a data stream to collect ACD group information, from the ACD node, to produce real-time statistics and historical reports. The ACD/MIS Interface allows the user to perform the following functions:

- login or logoff the ACD/MIS,
- collect information from a pool of ACD groups,
- change the information for a pool of ACD groups,
- request information on the configuration of the data stream,
- request the current time and date,
- start and stop the transfer of call-event information.

This feature also includes the following:

- **Remote ACD Load Management** - Provides the capability for supervisors to quickly reconfigure the structure and operational parameters of an ACD group to maximize the number of calls served or to alleviate overload on a remote supervisory terminal.
- **Variable Wrap-Up Time** - Allows the ACD supervisory position to vary the interval between call completion and the presentation of a new incoming call on an individual agent position basis or on a group basis.

Multistage-Queue Status Display - Allows the ACD agent to display the length of time calls have been held in the incoming call queue before being answered.

Music on Delay - This feature uses a customer provided music source to provide music to the caller after the recorded delay announcement, while the call is in queue to be answered.

Night Treatment - Allows calls arriving after all agents have logged out to be handled by: 1) answering with a recorded announcement advising the caller that the ACD location is closed and then the call is disconnected, or 2) automatically forwarding the call to another ACD location or to a night service number for answering.



Effective: April 1, 2016

---

CENTREX SERVICE

I. SPECIAL CONDITIONS (Continued)

X. CENTREX AUTOMATIC CALL DISTRIBUTION/MANAGEMENT INFORMATION SYSTEM (ACD/MIS) (Continued)

2. DEFINITIONS (Continued)

Not Ready - When the not ready key is pressed, any active call is terminated and the position cannot receive any new ACD calls. Non-ACD functions will continue to be presented as usual.

Observe Agent - Allows the supervisor position to monitor agents' calls. Monitoring capability is restricted to agents within a supervisor's group.

Observe Agent From 2500 Set - Allows the supervisor to monitor agents' calls from a 2500 set.

Overflow Enhancement - Increases the customer's options for answering ACD calls during periods of heavy traffic. Customers may specify up to four ACD groups, within an ACD node, as potential overflow routes. When an incoming call queue for a group is full, this feature sequentially scans each of the other groups and routes the call to the first group able to accept it.

Ring Threshold - Provides for the rerouting of a call when an agent does not answer within a preprogrammed length of time. The call is then rerouted either to the longest idle agent or to the front of the incoming call queue if no agent is available.

Set Not Ready - When activated, this feature blocks the agent's position from incoming ACD calls; non-ACD incoming calls continue to be presented. This feature is set up on a per set basis and is an enhancement to the Not Ready feature.

Standard Announcements - This feature plays recorded announcements to callers in queue to advise them of answering delays. The announcements are provided from the Company central office.

Supergroups - Enables multiple ACD groups, located in single or multiple locations but served by the same ACD node, to distribute calls dynamically among the separate groups based on the current available resources.

Supervisor Control of Night Service - Provides the supervisor position the capability to activate Night Treatment service for one or more agent groups within the same ACD system. This feature can eliminate or minimize calls left unanswered in the incoming call queue at the onset of night service.

Three-Way Calling/Call Transfer to ACD - This feature permits a supervisor to transfer a call to another agent with or without establishing a three-way conference first.

Transfer to In-Calls Key - Enables the ACD agent to transfer an incoming ACD call directly to another ACD agent's in-calls key.

Effective: April 1, 2016

---

CENTREX SERVICE

I. SPECIAL CONDITIONS (Continued)

X. CENTREX AUTOMATIC CALL DISTRIBUTION/MANAGEMENT INFORMATION SYSTEM (ACD/MIS) (Continued)

3. FEATURE PACKAGES

Centrex ACD is available in the following packages:

1. Basic Agent Feature Package
  - Abandoned Call Clearing
  - Agent Login/Logout
  - Agent Queue
  - Attendant Console to ACD
  - Automatic Overflow
  - Call Forcing
  - Delay Treatment
  - Incoming Call Queue (equal to number of agents)
  - Music on Delay
  - Night Treatment
  - Not Ready
  - Overflow Enhancement
  - Ring Threshold
  - Standard Announcements
  - Three-Way Calling/Call Transfer to ACD
2. Advanced Agent Feature Package <sup>1</sup>
  - ACD Overflow of Enqueued Calls
  - ACD Multiple Line of Business Codes
  - Call Transfer with Time
  - Emergency Alerting
  - Emergency Alerting Enhanced
  - Transfer to In-Calls Key
  - Available with Display Sets
  - ACD Walkaway/Closed
  - Called Name/Number Display
  - Call Source ID
  - Call Supervisor
  - Multistage-Queue Status Display

<sup>1</sup> Customers must subscribe to the Basic Agent Feature Package to be eligible to subscribe to the Advanced Agent Feature Package.

Effective: April 1, 2016

---

CENTREX SERVICE

I. SPECIAL CONDITIONS (Continued)

X. CENTREX AUTOMATIC CALL DISTRIBUTION/MANAGEMENT INFORMATION SYSTEM (ACD/MIS) (Continued)

3. FEATURE PACKAGES (Continued)

3. ACD on Single-Line Telephone Sets <sup>1</sup>

- Abandoned Call Clearing
- Automatic Overflow
- Distinctive Ringing
- Incoming Call Queue (equal to number of agents)
- Login/Logout
- Make Set Busy
- Music on Delay
- Night Treatment
- Observe Agent from 2500 Set
- Overflow Enhancement
- Ring Threshold
- Set Not Ready
- Standard Announcements
- Three-Way Calling/Call Transfer to ACD

4. Supervisor Feature Package

- Answer Agent
- Call Agent
- Controlled Interflow
- Emergency Answer
- Emergency Answer Backup
- Forced Agent Availability
- Observe Agent
- Supervisor Control of Night Service
- Three-Way Calling/Call Transfer to ACD
- Available with Display Sets
- Called Name/Number Display
- Call Source ID
- Display Agents Summary
- Display Queue Status

5. Optional Features <sup>1</sup>

- ACD Secondary Directory Number(s)
- MIS Data Stream Interface, which includes:
- Remote ACD Load Management
- Variable Wrap-Up Time
- Additional Queue Slots (for queue slots greater than the number of access positions)
- Supergroups

<sup>1</sup> The ACD on Single-Line Telephone Set Feature Package is in lieu of the Basic Agent Feature Package and not available with the Advanced Agent Feature Package.

Effective: April 1, 2016

---

CENTREX SERVICE

I. SPECIAL CONDITIONS (Continued)

X. CENTREX AUTOMATIC CALL DISTRIBUTION/MANAGEMENT INFORMATION SYSTEM (ACD/MIS) (Continued)

4. TERMS AND CONDITIONS

Centrex ACD Service is available only to customers served from central offices equipped with DMS-100 switches.

The customer must provide compatible premises equipment for MIS functionality. Some features may require a particular software release level in a customer-provided MIS to function to its fullest extent.

Agent Positions may be equipped with customer-provided electronic and/or nonelectronic telephone sets within the same system and group.

Centrex ACD/MIS Service is subject to all general terms and conditions applicable to the provision of service by the Company as specified in other sections of this Product Guide.

An intraexchange private line data circuit (4-wire circuit) is required between the customer's Management Information System and the Company serving central office. See the Facilities for Intrastate Access Tariff C-1.

The customer must subscribe to the Basic Agent Feature Package before subscribing to the Advanced Agent Feature Package or Optional Features.

In addition to the rates for Call Center Manager, the customer is required to purchase the following for each Call Center Manager; software, a modem, a 4-wire analog data circuit from the serving central office to the customer's premises, and data processing equipment including but not limited to at least a 486 personal computer, monitor, and a printer.

Y. MULTILOCATION CENTREX SERVICE

1. GENERAL

Customers requesting Multilocation Centrex Service must have established basic Centrex Service out of their serving wire center.

Multilocation Centrex Service allows customers having Centrex Service at multiple locations and/or terminating in multiple Telecommunications Systems to interact as though they were all within the same business group. The multiple locations may be on different premises served by the same end office, served by different end offices within the same exchange or served by different end offices in different exchanges. All end offices must be capable of providing Centrex Service.

Multilocation Centrex Service uses the public switched network to provide capabilities and features typically offered by a private network. End user access via one of the service's Dialing Plans will operate across the network as if the customer were being served by a single switch. Multilocation Centrex Service includes the following features:

- Dialing Plan
- Interlocation Intercom Calling

---

CENTREX SERVICE

I. SPECIAL CONDITIONS (Continued)

Y. MULTILOCATION CENTREX SERVICE (Continued)

2. DEFINITIONS

Access to Private Facilities - Access to Private Facilities gives a Multilocation Centrex customer access to private one-way or two-way facilities, i.e., T1, Tie Lines, WATS, FX Lines, etc., which are terminated in a Centrex system. These facilities terminate in a different Centrex system than the user. To use the Access to Private Facilities feature, the caller dials a one to three digit access code, which is routed via the Public Switched Network to the facility desired.

Customer of Record - The Centrex customer subscribing to Multilocation Centrex Service.

Dialing Plan - The dialing plan applies to internal station-to-station dialing only. Incoming DID calls are completed independent of the dialing plan selected. Two different dialing plans are available: 1) Location Code/Extension Dialing Plan, and 2) Portable Extension Dialing Plan. All intercom numbers for an individual customer must utilize the same dialing plan and must be the same length (2 to 7 digits).

- (a) Location Code/Extension Dialing Plan - Utilizes a unique location code for each site along with an extension number. Individual intercom numbers have two components: 1) a one to three digit location code, which must begin with the numbers two through six; and 2) one to six digits corresponding to a portion of the customer's local North American Numbering Plan (NANP) number. This dialing plan allows extension numbers to be reused at several locations.

Extension Dialing utilizes intercom numbers consisting of a portion of the NANP number associated with the individual line. This dialing plan allows for a simple intercom number based on part of the assigned NANP number.

- (b) Portable Extension Dialing Plan - Allows the customer to select any intercom number scheme, with individual intercom numbers transferable between customer locations. The intercom numbers do not relate to any portion of the NANP number. This dialing plan allows customers to keep the same intercom number when relocating to another customer site while being assigned a new NANP number for DID calls. Internal customer telephone directories do not have to be reprinted to remain current with employee job and location changes.

Both Dialing Plans can be used with public switched network calling or private line networks.

Effective: April 1, 2016

---

CENTREX SERVICE

I. SPECIAL CONDITIONS (Continued)

Y. MULTILOCATION CENTREX SERVICE (Continued)

2. DEFINITIONS (Continued)

Dialing Plan Numbers - Centrex lines having access to a Location/Extension Code or Portable Extension Dialing Plan.

Interlocation Intercom<sup>1</sup> - Interlocation intercom uses the public switched network instead of a dedicated private line network to complete calls between Centrex locations (inter-central office calls). Local Measured Service usage rates are applicable for these calls between locations. If these calls cross intraLATA toll boundaries, customers will be assessed Local Measured Usage charges and IntraLATA Toll rates (or Discounted Calling Plan rates as applicable) within their service locations.

Interlocation Intercom is available on a term and volume basis in which local usage is applicable or on a flat rated basis in which there is no additional charge for local usage.

Work-At-Home (WAH) - Work-At-Home allows a residential telephone number of the customer's employee to function as a Multilocation Centrex station on a call-by-call basis. The user dials an access code which enables the residential line to operate with features such as dial 9 access, Interlocation Intercom, or Access to Private Facilities.

The WAH capability is assigned to the employee's residential R1 line, and the WAH user cannot dial the access code for WAH from a line other than his own.

Work-At-Home may only be equipped on telephone lines of authorized employees of the Multilocation Centrex customer of record. The Multilocation Work-At-Home may only be ordered by the Centrex customer of record. Work-At-Home is available only on locations where facilities permit.

<sup>1</sup> A customer is not required to provide all Centrex lines in their system with multilocation access capabilities (stations may be limited to intralocation or intra-central office calling).

Effective: April 1, 2016

---

CENTREX SERVICE

I. SPECIAL CONDITIONS (Continued)

Y. MULTILOCATION CENTREX SERVICE (Continued)

3. CONDITIONS

All Multilocation Centrex Service equipped lines must terminate at an authorized location of the Customer of Record. Authorized locations may include branches, factories, plants, etc., of the Customer of Record or a subsidiary of the Customer of Record.

The Multilocation Centrex customer must subscribe to both Interlocation Intercom and one Dialing Plan (Location Code/Extension or Portable Extension).

Location Code/Extension and Portable Extension Dialing Plans may not be mixed.

Location Code/Extension can be one to three digits in length. The first digit of the location code must be numbered two through six.

Portable Extension numbers may be one through seven digits in length. The first digit of the Portable Extension number must be numbered two through six.

Portable Extension numbers do not need to be the same as the North American Numbering Plan number.

Interlocation Intercom calls will only be connected to Multilocation Centrex Service equipped lines at authorized locations.

All Multilocation Centrex Service lines must be located at authorized locations of the same Customer of Record. Not every Centrex line in a customer's business group must be provisioned with Multilocation Centrex Service.

A customer does not have to purchase Dialing Plan and Interlocation Intercom in order to subscribe to Access to Private Facilities or Work-At-Home.

The Multilocation Centrex customer of record is responsible for all charges incurred by any employee using the Work-At-Home feature from the time of installation of the feature until it is disconnected. The Multilocation Centrex customer is responsible for the disconnection of the service when the employee leaves the Company.

The following Basic Centrex Service features will function as described below when a customer has subscribed to Multilocation Centrex Service:

Automatic Call Back Calling - Activated only when calling other stations within the same business group that are served by the same end office. Multilocation Centrex customers may not camp on stations in other Centrex systems.

Multilocation Centrex stations receiving calls from other Multilocation Centrex equipped stations in a different business group will receive the distinctive ring and call waiting tone of an outside call.

System Speed Calling - One System Speed Calling list per end office is provided for each business group. A Centrex station can only access the System Speed Calling list of its business group within its home central office.

Effective: April 1, 2016

---

CENTREX SERVICE

I. SPECIAL CONDITIONS (Continued)

Y. MULTILOCATION CENTREX SERVICE (Continued)

4. RATE CONDITIONS

Monthly Rates for Multilocation Centrex are in addition to rates and charges for the Primary Station Line.

Intercom calls outside the local and/or EAS calling scope of the originating Centrex line will be billed for local calls at the Local Measured Service rates (Section 4 of this Product Guide) and IntraLATA Toll charges (Section 16 of this Product Guide) for toll calling. Intercom calling is also available on a flat rated basis in which local usage charges are not applicable.

The term lengths for Multilocation Centrex must be the same in all locations and coincide with the customer's single location Centrex term.

The Location Code/Extension Dialing Plan, Portable Extension Dialing Plan and the Interlocation Intercom are available on a month-to-month basis or for term periods ranging from 12 to 60 months. When a term period is elected, the customer is liable for termination charges for each and/or any of the features.

The termination liability charges will be calculated as set forth in Special Condition W. preceding if a customer discontinues Centrex and/or Multilocation Centrex Service.



Effective: April 1, 2016

---

CENTREX SERVICE

I. SPECIAL CONDITIONS (Continued)

Z. CENTREX COMMUNICATIONS SYSTEM SERVICE

1. GENERAL

Centrex Communications System is a non-engineered Centrex-based service, which once the switch is pre-positioned, does not require operations to provision at the time of the customer order and does not require the customer to use the "dial 9" access code to place calls. Centrex Communications System is classified as a business service, and is offered as a complete service package only. The exchange access, intercommunication and features are not offered separately. Centrex Communications System is a customized package for small business and may not exceed a maximum of 30 lines (exception: There is a six-line limit in the DMS 10 Central Office). Centrex Communications System provides an enhanced dial tone from the Central office to the customer's premises along with an attractive menu of basic services.

Centrex Communications System is furnished from compatible digital type switching equipment located on the Company premises and includes the facilities necessary for intercommunication between Centrex lines within the customer's system.

Centrex Communications System Service includes local exchange service (no dial "9" required), direct inward-dialing to Centrex lines, identification and billing of outgoing long distance messages by line number where such billing is done by the Company, touch-tone calling service, and intercept to the main listed number.

No other Centrex features or classes of service can be mixed with Centrex Communications System Service. The customer has the flexibility of adding any combination of standard individual lines and hunt groups that meets the communications needs of the business as well as choosing features from within the offered Centrex Communications System package for each line or hunt group.

Centrex Communications System is available only where technically feasible.

2. SERVICE OPTIONS

**Basic Standard Services**<sup>1,2</sup> - Services included with a Centrex Communications System service line.

Call Transfer (All Calls)  
Call Hold  
Consultation Hold  
Intercom Dialing  
Three Way Calling  
Distinctive Ringing (Inside/Outside)<sup>3</sup>  
Assume Dial "9"

<sup>1</sup> Centrex Communications System Basic Service includes a network access line with Touch Tone and Direct Inward/Outward Dialing capability and may consist of a single line.

<sup>2</sup> See Section 4 of this Product Guide for applicable measured usage rates.

<sup>3</sup> This feature is specific to Centrex Communications System Service. See 26.M, FEATURE DESCRIPTIONS.

Effective: April 1, 2016

---

CENTREX SERVICE

I. SPECIAL CONDITIONS (Continued)

Z. CENTREX COMMUNICATIONS SYSTEM SERVICE (Continued)

2. SERVICE OPTIONS (Continued)

**Selectable Standard Services**<sup>1</sup> - Services listed in this section are available for each Centrex Communications System line at no additional charge. A customer may customize his service by selecting as many of the following services as desired for each individual Centrex Communications System line:

- Automatic Callback (within system only)
- Call Forwarding - Busy - Fixed
- Call Forwarding - No Answer - Fixed
- Call Forwarding (All Calls)
- Call Restriction Options :<sup>2</sup>
  - No Call Restrictions
  - Call Restriction One
  - Call Restriction Two
  - Call Restriction Three
  - Call Restriction Four
  - Call Restriction Five
  - Call Restriction Six
  - Call Restriction Seven
- Call Waiting/Cancel Call Waiting
- Dial Call Waiting-Originating
- Call Pick-Up Directed
- Call Pick-Up Group
- Hunting Series
- Hunting Multi-Line
- Speed Dialing

<sup>1</sup> Available only where technically feasible.

<sup>2</sup> These call restrictions are specific to Centrex Communications System Service. See X.13. Feature Descriptions following.

Effective: April 1, 2016

---

CENTREX SERVICE

I. SPECIAL CONDITIONS (Continued)

Z. CENTREX COMMUNICATIONS SYSTEM SERVICE (Continued)

2. SERVICE OPTIONS (Continued)

**Optional Services**<sup>1</sup> - Services listed in this section are also available for each Centrex Communications System line at an additional monthly recurring charge per feature:

Busy Redial  
Call Block (\*60)  
Call Park  
Call Park Directed  
\*69  
Caller ID - Number Only  
Caller ID  
Executive Busy Override  
Last Number Redial<sup>2</sup>  
Select Call Forwarding  
Priority Call

Additional features and feature packages available from other Product Guide sections include:

Call Trace<sup>3</sup>  
Enhanced Call Forwarding - Existing Number<sup>3</sup>  
Enhanced Call Forwarding - Existing w/Call Manager<sup>3</sup>  
Voice Messaging<sup>4</sup>  
Unlimited Local and Toll Usage for Business Feature Package Two A<sup>3</sup>  
Unlimited Local and Toll Usage for Business Feature Package Three<sup>3</sup>

3. TERM OPTIONS

- Month-to-Month
- Two-Year Term offered prior to April 26, 2008 (grandfathered to existing customers)
- Three-Year Term offered on or after April 26, 2008
- Two-Year Term offered on or after June 1, 2014

Centrex Communications System will be billed per billing account number within a customer's system.

4. ADDING LINES UNDER TERM OPTION

Additional Centrex Communications System lines may be added to an existing system, up to a maximum of 30, during the term period; applicable Service Order Activity Charges will apply. For customers subscribing to the two-year term plan, the term obligation, with respect to any additional lines, will be coterminous with such two-year term. Effective 4/26/08, this regulation will apply to the Communications System 3-year term plan.

<sup>1</sup> Available only where technically feasible.

<sup>2</sup> This feature is specific to Centrex Communications System Service. See X.13. Feature Descriptions following.

<sup>3</sup> See Section 8. of this Product Guide for rates and descriptions of these services.

<sup>4</sup> See Section 6 of this Product Guide for rates and description of Voice Messaging.

<sup>5</sup> For the 24-month term, offered on or after June 1, 2014, Plan 2 termination liability/early termination fees apply, as described in Section 2 of this Product Guide.

Effective: April 1, 2016

---

CENTREX SERVICE

I. SPECIAL CONDITIONS (Continued)

Z. CENTREX COMMUNICATIONS SYSTEM SERVICE (Continued)

5. TERMINATION LIABILITY

There is no termination liability for customers who have elected the Centrex Communications System month-to-month payment option.

When a Centrex Communications System customer chooses the 24-month or 36-month term option, and after 30 days following installation, chooses to disconnect or terminate Communications System service before the term expires, the customer will be liable for any termination charges applicable in Section 2 of this Product Guide.

Effective September 14, 2007, new or renewing customers who, after the first 30 days, partially disconnect service, will be charged termination liability on the disconnected lines as follows:

For those term plans covered under Section 2 of this Product Guide:

- (a) Customers with 2 lines in service who disconnect one or both lines will be assessed full termination liability as described in Special Condition W. preceding. Customer must maintain 2 lines to have Centrex Communications System Service.
- (b) Customers with 3 - 4 lines in service who disconnect any lines will be charged termination liability on the disconnected lines per the formula set forth in Section 2 of this Product Guide. Customer must maintain 2 lines to Centrex Communications System Service.
- (c) Customers with 5 or more lines who disconnect over 20% of the total number of lines in service will be charged termination liability on the disconnected lines per the formula set forth in Section 2 of this Product Guide.

For those term plans covered under Section 2 this Product Guide, please see that section for a description of the termination liability

6. TRANSFER OF TERM OPTION

With the written permission of the Company, the obligation to pay the Centrex Communications System charges for the remainder of the term period may be assigned to another customer, provided there is no change of location, and the new customer assumes all outstanding charges. See Section 2 of this Product Guide, for termination liability terms and conditions.

7. CENTREX COMMUNICATIONS SYSTEM

Centrex Communications System service lines sharing a common intercom arrangement and a primary directory listing will be considered a Centrex Communications System Service System. A system may not exceed a maximum of thirty Centrex Communications System Service lines. Centrex Communications System Service is classified as a business service and is offered only as a complete service. The exchange access, intercommunication and services are not offered separately.

Effective: April 1, 2016

---

CENTREX SERVICE

I. SPECIAL CONDITIONS (Continued)

Z. CENTREX COMMUNICATIONS SYSTEM SERVICE (Continued)

8. SUBSCRIBER LINE CHARGE

An applicable interstate Subscriber Line Charge will be applied to all Centrex Communications System lines. See Frontier Operating Companies Tariff FCC No. 14 and Frontier Operating Companies Tariff FCC No. 13 for rates.

9. INCOMING TOLL FREE SERVICE ACCESS ARRANGEMENT

Incoming calls on Toll Free Service access lines can be terminated on a Centrex Communications System service system. Incoming calls terminated in this manner may be transferred to other lines of the same Centrex Communications System.

10. OFF-PREMISES LINES

Centrex Communications System lines can be provided at a separate customer premise. No mileage charges apply to lines of the same Centrex Communications System that are located at different premises but situated within the same wire center serving area.

11. OPTIONAL CENTREX COMMUNICATIONS SYSTEM SERVICES

Optional services may be available where Company facilities permit at the rates specified in II. Rates and Charges E.3. The descriptions, terms and conditions for these services are specified in Section 30 of this Product Guide. Only the Centrex services specified in this section will be available under Centrex Communications System Service. Custom Calling and CLASS services not specified in this Product Guide will not be offered.

12. FEATURE RESTRICTION

Call Transfer, Three-Way Calling, Call Forwarding, Call Forwarding Busy, and Call Forwarding-Don't Answer may generate local, regional toll or long distance usage charges. If generated, these charges are the responsibility of the Centrex Communications System customer.

Effective: April 1, 2016

---

CENTREX SERVICE

I. SPECIAL CONDITIONS (Continued)

Z. CENTREX COMMUNICATIONS SYSTEM SERVICE (Continued)

13 FEATURE DESCRIPTIONS

**CENTREX COMMUNICATIONS SYSTEM BASIC STANDARD FEATURES**

The following features are automatically included on every the Centrex Communications System line, and are the backbone of the the Centrex Communications System offering:

**Assume Dial "9"** - Allows the customer to place calls outside the group without having to dial the access code "9".

**Touch Tone** - Provides touch tone signaling for dialing calls, and accessing features. Rotary dial telephones are not compatible with the Centrex Communications System.

**Direct Inward Dial (DID)** - The ability of each member of the the Centrex Communications System group to receive calls from outside the group directly to their station.

**Direct Outward Dial (DOD)** - The ability of each member of the the Centrex Communications System group to place calls to locations outside the group without first having to dial a "9" access code or use an attendant.

**Call Transfer (All Calls)** - The ability for the Centrex Communications System line to transfer an established incoming call to another line. The "transfer-to-line" location may be inside the group or outside the group. This service may generate local, regional toll or long distance usage charges. If generated, these charges are the responsibility of the the Centrex Communications System customer.

**Call Hold** - The ability to place an established call on hold for an extended period of time by dialing the feature code \*01. This frees the line to place or receive another call. Only one call can be put on hold at a time per line.

**Consultation Hold** - A temporary or soft hold activated by a hook-switch flash or link button that will place a call in progress on hold and activate dial tone. The dial tone enables the user to make another call for private consultation or to activate a three-way call.

**Three Way Calling** - Provides the user with the ability to add a third party, from within the group or outside the group, to any established call for a three-way conference arrangement. This service may generate local, regional toll or long distance usage charges. If generated, these charges are the responsibility of the the Centrex Communications System customer.

**Intercom Dialing** - Provides the customer with the ability to communicate between lines within your own the Centrex Communications System group by dialing a two-digit code instead of having to dial the full 7- or 10-digit telephone number.

**Distinctive Ringing (Inside/Outside)** - This feature allows the user to distinguish between calls originating from within the the Centrex Communications System group and calls originating from outside the the Centrex Communications System group. Calls originating from inside the group will receive one ring, and calls originating from outside the group will receive a double ring. This feature is specific to the Centrex Communications System Service.

---

CENTREX SERVICE

I. SPECIAL CONDITIONS (Continued)

Z. CENTREX COMMUNICATIONS SYSTEM SERVICE (Continued)

13 FEATURE DESCRIPTIONS (Continued)

CENTREX COMMUNICATIONS SYSTEM SELECTABLE FEATURES

The following features may be selected at no charge by the customer, and may be placed on any Line or Hunt Group of the customer's choosing.

**Automatic Call Back (within system only)** - When a Centrex Communications System user reaches a busy line within the Centrex Communications System group, a code (\*52) may be dialed which allows the call to be connected when both lines are idle. This feature is for use inside the Centrex Communications System group only, and only one request at a time from a line is permitted. The request will remain active for a period of time not to exceed 30 minutes unless it is deactivated earlier by the originator, by dialing a code (#52).

**Call Forwarding (All Calls)** - Allows the customer to have all incoming calls routed to another number (either inside or outside the group). The user chooses and provisions the forwarded-to number, and may change the forwarded-to number as often as desired. The user also has the ability to turn the feature off and on as needed to better serve the user's needs. Calls forwarded outside the Centrex Communications System group are subject to local and/or long distance charges billed to the Centrex Communications System customer.

**Call Forwarding – Busy** - A fixed feature, provisioned by the Company using data provided by the customer, to automatically route all incoming calls to another number (either inside or outside the group or to Voice Messaging) when the called line is busy. Calls forwarded outside the Centrex Communications System group are subject to local and/or long distance charges billed to the Centrex Communications System customer.

**Call Forwarding - No Answer** - A fixed feature, provisioned by the Company using data provided by the customer. To automatically route all incoming calls to another number (either inside or outside the group or to Voice Messaging) when the called line is not answered in a predetermined number of rings/seconds. Calls forwarded outside the Centrex Communications System group are subject to local and/or long distance charges billed to the Centrex Communications System customer.

**Call Waiting/ Cancel Call Waiting** - When a busy Centrex Communications System line receives an incoming call, a tone is heard announcing that an incoming call is being received. The user then has the option of either placing the present call on hold and answering the incoming call, or disregarding the call. The calling party will receive a ringing tone instead of a busy tone. The user may terminate the Call Waiting feature at any time by dialing the Cancel Call Waiting Code (\*70). Canceling the Call Waiting feature is good for only one call, and must be repeated for each call the user does not wish to be interrupted by the call waiting tone.

**Dial Call Waiting-Originating** - When a user calls another member of the Centrex Communications System group and reaches a busy signal, the user can dial a code (\*54) to send a call waiting tone to the called line. The called line, upon hearing the tones, can terminate the call in progress, place the call in progress on hold, or disregard the call waiting tone. This feature can be activated or deactivated by the user.

---

CENTREX SERVICE

I. SPECIAL CONDITIONS (Continued)

Z. CENTREX COMMUNICATIONS SYSTEM SERVICE (Continued)

13 FEATURE DESCRIPTIONS (Continued)

CENTREX COMMUNICATIONS SYSTEM SELECTABLE FEATURES (Continued)

**Call Pick-Up Directed** - This feature enables a user to answer (pick-up) calls directed to any other line within the Centrex Communications System group by dialing a code (\*18) and the number of the ringing line, even if the user and the ringing line are not in the same call pick-up group. If more than one user tries to pick-up the call, only the first user will receive the call, and the others will receive a busy tone to identify the call was answered.

**Call Pick-Up Group** - This feature allows the user to answer (pick-up) any call directed to any other line within the user's Pick-Up Group simply by dialing a Call Pick-Up Code (\*17).

**Hunting (Series and/or Multi-Line)** - Hunting allows the customer to eliminate busy signals and increase the Company's accessibility by expanding call coverage. Hunting begins with a call to a lead number or pilot number, and searches for an idle line beginning with the first number of a pre-assigned hunt group and ending with the last number in the group. Hunting for Centrex Communications System customers will be provided in a Series or Multi-Line arrangement only, and must be programmed by Frontier from data provided by the customer.

Note: Circular or any other type hunting sequence is not available to Centrex Communications System customers.

**Customer Changeable Speed Calling** - This feature allows the user to make calls to frequently-dialed numbers by using an abbreviated code for each number. The short list consists of eight (8) numbers in all switch types except the 5ESS, which will only provide six (6). This is a customer programmable feature, and each user will have his own list.

**Call Restriction Options** - The customer must select the type of call restriction desired for each individual line. The customer request for each line must be identified on the service order so the line can be provisioned with the proper line class code and call blocking features.

The customer must choose one of the following options. <sup>1</sup>

**No Call Restrictions** - This option allows the user to make and receive calls without any restrictions of any kind.

**Call Restriction One** - This option blocks all outgoing chargeable toll calls including all operator calls. It allows outgoing local calls (outside the group), 8XX calls, local DA calls, repair calls, and 911 calls only. This option allows all incoming calls with no restrictions.

**Call Restriction Two** - This option blocks all outgoing direct dialed chargeable toll calls, but allows outgoing operator handled calls for class call screening (third number, collect, or credit card only), local calls (outside the group), 8XX calling, local DA calls, repair calls, and 911 calls. This option allows all incoming calls with no restrictions.

<sup>1</sup> These call restrictions are specific to Centrex Communications System Service.



---

CENTREX SERVICE

I. SPECIAL CONDITIONS (Continued)

Z. CENTREX COMMUNICATIONS SYSTEM SERVICE (Continued)

13 FEATURE DESCRIPTIONS (Continued)

CENTREX COMMUNICATIONS SYSTEM SELECTABLE FEATURES (Continued)

**Call Restriction Options** (Continued)

The customer must choose one of the following options. <sup>1</sup> (Continued)

**Call Restriction Three** - The user is not permitted to make any outgoing calls to numbers outside the Centrex Communications System group (toll or local, including 911). This option allows all incoming calls with no restrictions.

**Call Restriction Four** - The user cannot make or receive calls to or from outside the Centrex Communications System group (including 911). Only inside the group (intercom) calling is allowed.

**Call Restriction Five** - This option blocks all 700, 900, 976 calls. This option may be added to the No Call Restriction class of service as required.

**Call Restriction Six** - This option blocks all casual dialing (101XXXX) type calls. This option may be added to the No Call restriction class of service as required.

**Call Restriction Seven** - This option blocks all international type calls. This option may be added to the No Call Restriction class of service as required.

CENTREX COMMUNICATIONS SYSTEM OPTIONAL FEATURES

These features may be selected by the customer and may be added to any line or hunt group of the customer's choosing; however, there will be additional charges for these features.

**Busy Redial** - This feature allows the user attempting to call to a busy line, within the defined calling area, to dial a code (\*66) and be automatically connected to that line when both lines are idle. Once activated, a 30 minute queuing process begins with a voice prompt advising the user that the network will attempt the call again. The user will be alerted with a special ring when the call is returned.

**Call Block (\*60)** - This feature provides the user the ability to block up to twelve external telephone numbers, of their choosing, from terminating a call to the user's line. The numbers the user chooses to block must be from the user's defined calling area. Calls from outside the user's defined calling area and operator calls cannot be blocked. Once activated, any calls from these twelve numbers will be routed to an intercept message instead of completing.

**Call Park** - This feature allows the user to "park" a call against his own number, and then retrieve the call from any other station in the group. Only one call can be parked on any one number at a time.

<sup>1</sup> These call restrictions are specific to Centrex Communications System Service.

---

CENTREX SERVICE

I. SPECIAL CONDITIONS (Continued)

Z. CENTREX COMMUNICATIONS SYSTEM SERVICE (Continued)

13 FEATURE DESCRIPTIONS (Continued)

CENTREX COMMUNICATIONS SYSTEM OPTIONAL FEATURES (Continued)

**Call Park Directed** - This feature is an enhanced call park feature and enables the user to "park" a call on any number within the Centrex Communications System group, except his own number, and then retrieve the call from the number the call was parked on. Only one call can be parked on any one number at a time.

**\*69** - This feature allows a customer to return the last incoming call when the service is activated by dialing \*69.

This feature is offered on a monthly subscription or per activation basis.

Per activation customers are charged upon dialing \*69, regardless of whether the call is completed to the calling party. The customer is charged for any call placed by means of this service.

Custom Local Area Signaling Service (CLASS) features are applicable to calls placed to/from compatible central offices or within a compatible central office offering the service. These services are offered based on information stored within the switch or provided to the switch through call setup signaling and are subject to limitations associated with the availability and content of that information.

**Caller ID-Number Only** - This feature allows the user (with compatible CPE) to view the telephone number of the incoming call before answering the call or choosing to ignore it.

**Caller ID** - This feature allows the user (with compatible CPE) to view the telephone number and listed name (LN), of the incoming call before answering the call or choosing to ignore it.

**Executive Busy Override** - This feature allows the user, upon reaching a busy line inside the group, to dial a code (\*40) to gain access to the busy line, thus establishing a three-way call. The called number must be in the Centrex Communications System group, and will receive a warning tone prior to the establishment of the three-way conference call.

**Last Number Redial** - This feature enables the user to redial the last called number by dialing a code (#77) rather than having to dial the entire number. This feature is not available in the 5ESS. This feature is specific to Centrex Communications System Service.

**Select Call Forwarding** - This feature allows the user the ability to program up to twelve numbers of his choosing that he wants call forwarded. When one of the numbers on the user list calls, the call will be forwarded to the number the user has programmed to receive the call. Calls from all other numbers will be handled in the normal manner. If call forwarding all calls is activated, it will override this feature.

---

CENTREX SERVICE

I. SPECIAL CONDITIONS (Continued)

Z. CENTREX COMMUNICATIONS SYSTEM SERVICE (Continued)

13 FEATURE DESCRIPTIONS (Continued)

CENTREX COMMUNICATIONS SYSTEM OPTIONAL FEATURES (Continued)

**Enhanced Call Forwarding – Existing Number & Existing Number With Call Manager** – is an AIN-based service. Using a toll-free 800 number, subscribers can forward calls from anywhere in the country to another number of their choice (pager, cellular phone, work phone, or home phone). Enhanced Call Forwarding (ECF) is installed with a default destination number requested by the end user, and provides the added flexibility for subscribers to override the default number at will by using prompts on the Administrative IVRU number. See Section 7 of this Product Guide for other details and rates for ECF.

**Priority Call** - This feature provides the user the ability to identify up to twelve numbers he wants to receive a special notification when a call is received from one of the numbers. A special ring (short-long-short) will be used to notify the user of a call from one of the numbers on the special list. This feature will not work on a hunt group pilot number.

**Voice Messaging** - This feature allows the user to have busy and no answer calls forwarded to a voice messaging server to take a message if the caller chooses to leave one. If the customer has Voice Messaging, the Call Forwarding Busy and No Answer features are used for Voice Messaging programming purposes, and are not available for forwarding to other locations.

**Call Trace** - Allows the user to trace the number of the last calls received, and have the number automatically reported to the Company.

**Unlimited Local and Toll Usage for Business Feature Package Two A** - Allows the Centrex Communications System customer who subscribes to Unlimited Local and Toll Usage for Business<sup>1</sup> to also subscribe, on the same line(s), to either or both Caller ID and/or Voice Messaging offered in Feature Package Two A.

**Unlimited Local and Toll Usage for Business Feature Package Three** - Allows the Centrex Communications System customer who subscribes to Unlimited Local and Toll Usage for Business<sup>1</sup> to also subscribe, on the same line(s), to either or both Caller ID and/or One Point Voice Mail (OPVM) offered in Feature Package Three.

<sup>1</sup> See Section 8 of this Product Guide for rates and descriptions of these services.

CENTREX SERVICE

II. RATES AND CHARGES

A. OPTIONAL FEATURES

The following optional features are available to all Centrex Customers (Package 1000, 2000, 3000 and Dormitory Service).

	<u>Nonrecurring Charge</u>	<u>Monthly Rate</u>
1. Paging Interface	\$105.00	\$26.85
2. Customer Moves and Changes (CMAC) <sup>1</sup>		
1 - 100 lines	190.00	85.00
101 - 200 lines	350.00	140.00
201 - 500 lines	800.00	200.00
501 - 1500 lines	1,850.00	300.00
1501 + lines	3,500.00	425.00
3. Direct Digital Interface (DDI) <sup>2</sup> For use with High Capacity Digital Channel	150.00	350.00
4. Conference Calling, each circuit	150.00	124.32
5. Music on Hold Interface	150.00	130.00
6. Automatic Route Selection (ARS)/ Flexible Route Selection (FRS) Upgrade		
(a) upgrade to a capacity of 32 patterns per customer group	100.00	21.25
(b) upgrade to a capacity of 64 patterns per customer group	200.00	30.50
(c) 6 digit routing to selectively route calls over 2 or more routes within an NPA, per NPA.	50.00	13.75
(d) Customer requested change of prefixes and/or codes within A basic and/or upgraded pattern, each pattern.	35.00	--

<sup>1</sup> Both the Nonrecurring Charge and Monthly Rate apply per customer group per central office.

<sup>2</sup> Channel Rate in the Facilities for Intrastate Access Tariff C-1.

Effective: April 1, 2016

---

CENTREX SERVICE

II. RATES AND CHARGES (Continued)

A. OPTIONAL FEATURES (Continued)

The following optional features are available to all Centrex Customers (Package 1000, 2000, 3000 and Dormitory Service). (Continued)

	<u>Nonrecurring Charge</u>	<u>Monthly Rate</u>
7. ISDN-PRI Centrex Access <sup>1</sup> , per PRI	\$200.00	--
8. ISDN-PRI Voice over Internet Protocol (VOIP) Centrex Access <sup>1</sup> , per block of 100 DID or individual telephone numbers <sup>2</sup> each additional number added	235.00 2.50	
9. Single Digit Dialing, per customer group	35.00	\$5.00
10. Speed Dialing 30	5.00	1.50
11. Auto/Universal Call Distribution (ACD/UCD)	150.00	35.00
12. Trunk Queuing	5.00	1.50
13. Attendant Position Interface	200.00	200.00

<sup>1</sup> ISDN PRI Access and Tie Channel Service or Tie Channel to an Intermediary Customer Service is provided per the Facilities for Intrastate Access Services Tariff C-1.

<sup>2</sup> Initial installations are charged at the Per Block of 100 DID Numbers rate. For subsequent additions, Per Block of 100 DID Numbers or Each Addition Number rate may apply.

Effective: June 21, 2016

CENTREX SERVICE

II. RATES AND CHARGES (Continued)

A. OPTIONAL FEATURES (Continued)

The following optional features are available to all Centrex Customers (Package 1000, 2000, 3000 and Dormitory Service). (Continued)

	<u>Nonrecurring Charge</u>	<u>Monthly Rate</u>	
14. Terminations in Centrex Switching Equipment			
a. Private line terminal, each termination (does not apply to manual tie lines)	\$120.00	\$30.00	
Changes to existing private line terminal, each terminal	50.00	-	
b. Tandem private line terminal, each termination	120.00	35.00	
Changes to existing tandem private line terminal, each terminal	50.00	-	
c. Foreign Exchange and special services terminal, each termination	120.00	30.00	
d. In WATS termination <sup>1, 2</sup>	50.00	5.00	
e. Assume Dial "9"			
(1) Each customer group	500.00	85.00	(T)
15. Meet me Conference	150.00	124.31	
16. Recorded Announcement	150.00	75.00	

<sup>1</sup> Access line rate in Section 30 of this Product Guide.

<sup>2</sup> Wide Area Telecommunications Service (WATS) is grandfathered and limited to existing customers at existing locations as of January 13, 2005.

CENTREX SERVICE

II. RATES AND CHARGES (Continued)

A. OPTIONAL FEATURES (Continued)

The following optional features are available to all Centrex Customers (Package 1000, 2000, 3000 and Dormitory Service). (Continued)

	<u>Nonrecurring Charge</u>	<u>Monthly Rate</u>
17. Dormitory Service	\$50.00	1
a. Feature Package, each station		\$2.00
b. Installed primary station line, each line	20.00	
18. Expanded Optional Features		
a. Automatic Route Selection (ARS)/Flexible Route Selection (FRS)		
(1) Common equipment, per customer group	500.00	175.00
(2) 3-digit Routing to selectively route calls over two or more routes		
(a) Capacity of 8 patterns, per customer group	50.00	12.50
(b) Capacity of 32 patterns, per customer group	100.00	21.25
(c) Capacity of 64 patterns, per customer group	200.00	30.50
(3) 6-digit Routing to selectively route calls over two or more routes within a NPA		
Per NPA	50.00	13.75
(4) Customer requested change of prefix or codes within a pattern		
Per pattern	35.00	-
(5) Programming - WATS <sup>1</sup> access lines included, each set-up or change	350.00	-

<sup>1</sup> Individual Line Residential Service rate is applicable as shown in the General Exchange Tariff, Schedule No. A-1.

CENTREX SERVICE

II. RATES AND CHARGES (Continued)

A. OPTIONAL FEATURES (Continued)

The following optional features are available to all Centrex Customers (Package 1000, 2000, 3000 and Dormitory Service). (Continued)

	<u>Nonrecurring Charge</u>	<u>Monthly Rate</u>
18. Expanded Optional Features (Continued)		
b. Message Detail Recording (MDR)		
(1) Common Equipment per customer group	\$100.00	\$81.25
Each group of 50 or fewer stations	2.00	-
(2) Message Detail		
Per line	-	0.30
c. Authorization Codes, per group of 10	100.00	10.00
d. Code Call Access	100.00	25.00
e. Dictation Access and Control	100.00	25.00
f. Preferential Hunting, per line	-	0.50
g. Priority Queuing, per system	25.00	1.00
h. Stop Hunt, per system	25.00	1.80
i. Terminal Make Busy, per system <sup>1</sup>	25.00	1.80
j. Time of Day Routing	560.00	10.00

<sup>1</sup> Wide Area Telecommunications Service (WATS) is grandfathered and limited to existing customers at existing locations as of January 13, 2005.



Effective: April 1, 2016

---

CENTREX SERVICE

II. RATES AND CHARGES (Continued)

A. OPTIONAL FEATURES (Continued)

The following optional features are available to all Centrex Customers (Package 1000, 2000, 3000 and Dormitory Service). (Continued)

	<u>Nonrecurring Charge</u>	<u>Monthly Rate</u>
18. Expanded Optional Features (Continued)		
k. Exchange and Toll Message Diverting		
(1) Common Equipment, per diverting pattern	\$135.00	\$15.00
(2) Each 10 NXXs Programmed	135.00	-
(3) Each 10 NPAs Programmed	75.00	-
l. Direct Connect Service, each <sup>2</sup>	30.00	5.00
19. Proprietary Interface, each		5.00
20. Pseudo Number	-	6.00

<sup>1</sup> Service may require Private Line Channels to activate this service.

<sup>2</sup> This charge is in addition to the normal Section 3 of this Product Guide charges applicable when establishing service.

Effective: April 1, 2016

---

CENTREX SERVICE

II. RATES AND CHARGES (Continued)

A. OPTIONAL FEATURES (Continued)

	<u>Nonrecurring Charge</u>
21. Data Base Changes	
a. Major Software Additions	\$100.00
- Add Customized Dialing Plan	
- Add Customer Requested Data Base Profile	
b. Routine Software Change <sup>1</sup>	50.00
- Change Trunk Group	
- Change Non-Data-Link Attendant <sup>2</sup>	
- Change Customer Recording	
c. Minor Software Change <sup>1</sup>	25.00
- Change Subgroup	
- Hunt Groups	
- ACD Hunt Group	
- Queuing Groups - (Each)	
- Night Answer (UNA/PNA) - (Each Number)	
- Paging/Public Address/Code Calling - (Each Area)	
- Conference Calling	
- Remote Access Directory Number - (Each Code)	
- Authorization Code Validation - (Each Code)	
- Dictation Link Access	
- Extended Pick Up Code	
- Change Line Features	
- Unrestricted Call Transfer	

<sup>1</sup> Applies to changes to existing services.

<sup>2</sup> Plus an additional minor software change charge for each additional console.

CENTREX SERVICE

II. RATES AND CHARGES (Continued)

A. OPTIONAL FEATURES (Continued)

	<u>Nonrecurring Charge</u>	<u>Monthly Rate</u>
22. Exchange and Toll Message Diverting		
Each change in diverting pattern, per group of 10 NXX/NPA changes	\$50.00	
23. Instant Call Accounting (ICA)		
(1) Dedicated ICA, per system	2000.00	\$1000.00
(2) Dial-Up ICA, per system	1000.00	500.00
24. Call Trace <sup>1</sup>		
per line	--	6.00
25. Priority Call <sup>1</sup>		
per line	--	4.00
26. Caller ID - Number Only Service		
2 - 25 lines, per line	--	6.00
26 - 50 lines, per line	--	4.50
over 51 lines, per line	--	2.00
27. Caller ID Service		
2 - 25 lines, per line	--	7.00
26 - 50 lines, per line	--	5.50
over 51 lines, per line	--	3.00
28. Selective Blocking, per call	--	0.00
29. Complete Blocking per line	--	0.00

<sup>1</sup> Available to customers who subscribe to the Centrex Custom Calling Local Area Signaling Service (CLASS feature package only).

Effective: April 1, 2016

CENTREX SERVICE

II. RATES AND CHARGES (Continued)

A. OPTIONAL FEATURES (Continued)

	<u>Nonrecurring Charge</u>	<u>Monthly Rate</u>
30. Numbers Not In Use	--	--
31. Station Message Detail Recording (SMDR) <sup>1</sup>		
Dedicated Access <sup>2</sup>	ICB	ICB
Dial-Up Access		
2 – 200 lines	\$300.00	\$200.00
201 + lines	ICB	ICB
Internet Access <sup>3</sup>		
2 – 200 lines	300.00	200.00
201 + lines	ICB	ICB
Additions and Changes, per system change	<sup>4</sup>	--
32. Unlimited Local and Toll Usage for Business Feature Package Two B <sup>5</sup> choice of Caller ID and/or Voice Messaging	--	12.00
33. Unlimited Local and Toll Usage for Business Feature Package Three <sup>5</sup> choice of Caller ID and/or One Point Voice Mail (OPVM)	--	15.00

<sup>1</sup> Nonrecurring Charge applies in addition to appropriate service order charges as set forth in Section 3 of this Product Guide.

<sup>2</sup> SMDR may also be provisioned via Dedicated Access (to the customer's location). The call records are transmitted to the customer, via a dedicated voice grade circuit, from the central office to the customer location. This optional feature requires the customer to also subscribe to a minimum of a voice grade circuit. The rates and charges for the dedicated access are provided on an Individual Case Basis (ICB).

<sup>3</sup> Customer is responsible for obtaining connection to the Internet.

<sup>4</sup> Minor Software Change charges apply, as set forth in II. Rates and Charges A.21.c preceding.

<sup>5</sup> See Section 7 of this Product Guide for the terms and conditions of these services.

Effective: January 15, 2024

CENTREX SERVICE

II. RATES AND CHARGES (Continued)

B. STATION LINE / DISCOUNT PRICING PLAN (DPP)

Nonrecurring Charge  
(All Terms)

Installed primary station line, each line <sup>3</sup> \$20.00

Centrex customers may purchase service on a month-to-month or term commitment option of 12 Months, 36 Months, or 60 Months and receive discounted monthly rates as follows.

1. Centrex Line - Discount Pricing Plan (includes a Centrex Line only)

	<u>Monthly Rate per line <sup>1</sup></u>	<u>Monthly Rate per line <sup>2</sup></u>	
a. <u>Month-to-Month</u>			
2 - 25 lines	\$ 48.18	\$ 53.18	(l)
26 - 50 lines	40.41	45.41	
51 - 100 lines	44.63	49.63	(l)
101+ lines	43.86	48.86	(l)

<sup>1</sup> These rates are applicable to customers in exchanges listed in Section 5, Sheet 2 of this Product Guide. The End User Common Line Charge in the Frontier Operating Companies Tariff FCC No. 14, Section 13, will be applied.

<sup>2</sup> These rates are applicable to customers in exchanges listed in Schedule Section 5, Sheet 3 of this Product Guide. The End User Common Line Charge in the Frontier Operating Companies Tariff FCC No. 13, Section 4, will be applied.

<sup>3</sup> Service connection charges in Section 3 of this Product Guide will not apply to service order or central office activity. However, the Outside Facility Connection Charge will apply. The Subsequent Order Moves and Changes charge applies to all customers, with the exception of customers of CMAC. See Special Conditions A-C preceding.

Effective: January 15, 2024

CENTREX SERVICE

II. RATES AND CHARGES (Continued)

B. STATION LINE / DISCOUNT PRICING PLAN (DPP) (Continued)

1. Centrex Line - Discount Pricing Plan (includes a Centrex Line only)

	<u>Monthly Rate per line <sup>1</sup></u>		<u>Monthly Rate per line <sup>2</sup></u>	
b. <u>12 Month Term</u> <sup>4, 5, 7</sup>				
2 - 25 lines	\$36.79		\$36.79	
26 - 50 lines	34.01		34.01	
51 - 100 lines	35.24		35.24	
101+ lines	43.21	(I)	43.21	(I)
c. <u>36 Month Term</u> <sup>4, 5, 7</sup>				
2 - 25 lines	38.69	(I)	38.69	(I)
26 - 50 lines	32.91		32.91	
51 - 100 lines	32.14		32.14	
101+ lines	32.34		32.34	
d. <u>60 Month Term</u> <sup>4, 5, 6, 7, 8</sup>				
51 - 100 lines	28.27		28.27	
101 + lines	26.70		26.70	

<sup>1</sup> These rates are applicable to customers in exchanges listed in Section 5, Sheet 2 of this Product Guide. The End User Common Line Charge in the Frontier Operating Companies Tariff FCC No. 14, Section 13, will be applied.

<sup>2</sup> These rates are applicable to customers in exchanges listed in Section 5, Sheet 3 of this Product Guide. The End User Common Line Charge in the Frontier Operating Companies Tariff FCC No. 13, Section 4, will be applied.

<sup>3</sup>

<sup>4</sup> See Special Condition W. in this Section for termination liability terms and conditions applicable to cancellation or partial disconnection of Centrex Service.

<sup>5</sup> If the number of lines in service drops below the minimum number of lines agreed to in the term commitment plan, the rate will default to the rate applicable for the actual number of lines in service within that term plan.

<sup>6</sup> If the number of lines in service drops below the minimum number of lines available in the 60 month term commitment plan, the rate will default to the rate applicable for the actual number of lines in service within the 36 month term plan. The length of the term plan will remain at 60 months.

<sup>7</sup> The Subsequent Order Moves and Changes charge and the nonrecurring charge for the Installed Primary Station Line will not apply to the initial installation of Centrex lines when installed at Product Guide rates under a term commitment.

<sup>8</sup> Effective May 18, 2013, the 60-Month Term option is no longer available to new customers. Existing customers may retain their term payment option until it expires. Upon expiration, customers may re-subscribe to Month-to-Month, 12 Month or the 36 Month Term option.

Effective: January 15, 2024

CENTREX SERVICE

II. RATES AND CHARGES (Continued)

B. STATION LINE / DISCOUNT PRICING PLAN (DPP) (Continued)

2. Centrex Calling Solutions

Customers may elect this option and receive a discounted rate for the Centrex Line and IntraLATA Toll usage. This offer is composed of two elements: 1) the Centrex line, and 2) discounted IntraLATA Toll usage component. The rates in B.2.a below apply only in conjunction with the discounted long distance usage in B.2.b.

a. Centrex Calling Solutions Line (see B.2.b below for discounted toll rates)

<u>12 Month Term</u> <sup>3, 4, 6</sup>	<u>Monthly Rate</u> <u>Per Line</u> <sup>1</sup>		<u>Monthly Rate</u> <u>Per Line</u> <sup>2</sup>	
2 - 25 lines	\$20.45	(I)	\$27.34	(I)
26 - 50 lines	13.50		20.95	
51 - 100 lines	13.00		20.15	
101 + lines	12.50		19.40	
<u>36 Month Term</u> <sup>3, 4, 6</sup>				
2 - 25 lines	16.50	(I)	22.85	(I)
26 - 50 lines	11.00		17.05	
51 - 100 lines	10.50		16.30	
101 + lines	10.00		15.50	
<u>60 Month Term</u> <sup>3, 4, 5, 6</sup>				
51 - 100 lines	9.50		14.75	
101 + lines	8.50		13.20	

b. IntraLATA Toll Usage Rates<sup>7</sup>

	<u>Monthly Rate</u> <u>per minute</u> <sup>8</sup>
(1) Month-to-Month	
(2) 12 Month Term	25% Discount <sup>9</sup>
(3) 36 Month Term	\$ 0.0775 <sup>9</sup>
(4) 60 Month Term	0.0775 <sup>9</sup>

<sup>1</sup> These rates are applicable to customers in exchanges listed in Section 5, Sheet 2 of this Product Guide. The End User Common Line Charge in the Frontier Operating Companies Tariff FCC No. 14, Section 13, will be applied.

<sup>2</sup> These rates are applicable to customers in exchanges listed in Section 5, Sheet 3 of this Product Guide. The End User Common Line Charge in the Frontier Operating Companies Tariff FCC No. 13, Section 4, will be applied.

<sup>3</sup> See Special Condition W. in this Section for termination liability terms and conditions applicable to cancellation or partial disconnection of Centrex Service.

<sup>4</sup> If the number of lines in service drops below the minimum number of lines agreed to in the term commitment plan, the rate will default to the rate applicable for the actual number of lines in service within that term plan.

<sup>5</sup> If the number of lines in service drops below the minimum number of lines available in the 60 month term commitment plan, the rate will default to the rate applicable for the actual number of lines in service within the 36 month term plan. The length of the term plan will remain at 60 months.

<sup>6</sup> The Subsequent Order Moves and Changes charge and the nonrecurring charge for the Installed Primary Station Line will not apply to the initial installation of Centrex lines when installed at Product Guide rates under a term commitment.

<sup>1</sup> Customer must purchase the Centrex Line DPP to be eligible for these discounted rates.

<sup>2</sup> Discount Calling Plan rates in Section 28 of this Product Guide apply.

<sup>3</sup> Discount applies to IntraLATA Toll usage (see Section 28 of this Product Guide) on Centrex lines only. A minimum monthly usage charge of \$5.00 per line applies.

Effective: January 15, 2023

CENTREX SERVICE

II. RATES AND CHARGES (Continued)

B. STATION LINE / DISCOUNT PRICING PLAN (DPP) (Continued)

3. Centrex Feature Packages <sup>1,2</sup>

		<u>Nonrecurring Charge Per Customer Group</u>	<u>Monthly Rate per line</u>	
a.	<u>Month-to-Month</u>			
	(1) Feature Pak 1000	\$50.00	\$25.90	(I)
	(2) Feature Pak 2000	100.00	27.90	(I)
	(3) Feature Pak 3000	200.00	28.90	(I)
	(4) Centrex CLASS, per station <sup>3</sup>	-	5.00	
b.	<u>12 Month Term</u> <sup>4,5</sup>			
	(1) Feature Pak 1000	50.00 <sup>7</sup>	21.50	(I)
	(2) Feature Pak 2000	100.00 <sup>7</sup>	23.25	(I)
	(3) Feature Pak 3000	200.00 <sup>7</sup>	24.00	(I)
	(4) Centrex CLASS, per station <sup>3</sup>	-	5.00	
c.	<u>36 Month Term</u> <sup>4,5</sup>			
	(1) Feature Pak 1000	50.00 <sup>7</sup>	21.25	(I)
	(2) Feature Pak 2000	100.00 <sup>7</sup>	22.60	(I)
	(3) Feature Pak 3000	200.00 <sup>7</sup>	23.25	(I)
	(4) Centrex CLASS, per station <sup>3</sup>	-	5.00	
d.	<u>60 Month Term</u> <sup>4,5,6,8</sup>			
	(1) Feature Pak 1000	50.00 <sup>7</sup>	21.00	(I)
	(2) Feature Pak 2000	100.00 <sup>7</sup>	22.00	(I)
	(3) Feature Pak 3000	200.00 <sup>7</sup>	22.75	(I)
	(4) Centrex CLASS, per station <sup>3</sup>	-	5.00	

<sup>1</sup> See Special Condition 2 and 3 preceding for feature package descriptions.

<sup>2</sup> Feature package term length must match Centrex Line term length.

<sup>3</sup> The maximum monthly charge for the Centrex CLASS feature package is \$500.00 per customer.

<sup>4</sup> See Section 2 of this Product Guide, for termination liability terms and conditions.

<sup>5</sup> If the number of lines in service drops below the minimum number of lines agreed to in the term commitment plan, the rate will default to the rate applicable for the actual number of lines in service within that term plan.

<sup>6</sup> If the number of lines in service drops below the minimum number of lines available in the 60 month term commitment plan, the rate will default to the rate applicable for the actual number of lines in service within the 36 month term plan. The length of the term plan will remain at 60 months.

<sup>7</sup> The Subsequent Order Moves and Changes charge, the nonrecurring charge for the Installed Primary Station Line, and the Centrex Feature Package nonrecurring charge will not apply to the initial installation of Centrex lines when installed at Product Guide rates under a term commitment.

<sup>8</sup> Effective May 18, 2013, the 60-Month Term option is no longer available to new customers. Existing customers may retain their term payment option until it expires. Upon expiration, customers may re-subscribe to Month-to-Month, 12 Month or the 36 Month Term option.



Effective: April 1, 2016

---

CENTREX SERVICE

II. RATES AND CHARGES (Continued)

C. CENTREX AUTOMATIC CALL DISTRIBUTION/MANAGEMENT INFORMATION SYSTEM (ACD/MIS)

1. Package	Nonrecurring Charge <sup>1</sup>	Monthly Rate
Basic Agent Feature Package per ACD group per ACD line <sup>3</sup>	\$55.00	\$24.00
Advanced Agent Feature Package <sup>2</sup> per ACD group per ACD line	25.00	5.00
ACD on Single-Line Sets per ACD line <sup>3</sup>	10.00	22.50
Supervisor Feature Package per ACD line <sup>3</sup>	50.00	26.00
2. Optional Features <sup>2</sup>		
Secondary Directory Number	-	2.00
MIS Data Stream Interface per interface	100.00	100.00
Additional Queue Slots per system per slot	25.00	2.50
Supergroups per Supergroup	50.00	25.00
Call Center Manager <sup>4</sup>		
1st Call Center Manager	75.00	200.00
2nd Call Center Manager	75.00	150.00
3rd & Subsequent, each	75.00	125.00
Call Center Reporting per customer per agent	100.00	15.00

<sup>1</sup> Does not include appropriate nonrecurring charges from Section 3 of this Product Guide.

<sup>2</sup> Customers must have the Basic Agent Feature Package before they can subscribe to either the Advanced Agent Feature Package or the Optional Features.

<sup>3</sup> Does not include End User Common Line Charge in the Frontier Operating Companies Tariff FCC No. 14, Section 13.

<sup>4</sup> An intraexchange private line data circuit (4-wire circuit) is required between the customer's Management Information System and the Company serving central office.

Effective: April 1, 2016

CENTREX SERVICE

II. RATES AND CHARGES (Continued)

D. MULTILOCATION CENTREX SERVICE

1. LOCATION CODE/EXTENSION DIALING PLAN

	<u>Nonrecurring Charge <sup>1</sup></u>	<u>Monthly Rate Per Customer <sup>2</sup></u>
<u>Service Establishment</u> - (Per Customer)		
2 - 25 Lines	\$150.00	
26 - 50 Lines	175.00	
51 - 100 Lines	205.00	
101 + Lines	250.00	
 <u>Month-to-Month</u>		
2 - 25 Lines		\$50.00
26 - 50 Lines		65.00
51 - 100 Lines		125.00
101 + Lines		150.00
 <u>12 Month Term</u> <sup>3,4</sup>		
2 - 25 Lines		35.00
26 - 50 Lines		50.00
51 - 100 Lines		100.00
101 + Lines		125.00
 <u>36 Month Term</u> <sup>3,4</sup>		
2 - 25 Lines		25.00
26 - 50 Lines		35.00
51 - 100 Lines		75.00
101 + Lines		100.00
 <u>60 Month Term</u> <sup>3,4,5</sup>		
51 - 100 Lines		50.00
101 + Lines		75.00
 <u>Additions or Changes</u>		
(a) Addition or Change - per Location	65.00	
(b) Addition or Change - per Change to Dialing Plan		
First 25 Numbers	55.00	
Each Add'l Number	1.00	

<sup>1</sup> In addition to appropriate Nonrecurring Charges in Section 3 of this Product Guide.

<sup>2</sup> In addition to monthly rates for the Primary Station Line in this Product Guide.

<sup>3</sup> See Special Condition W. in this Section for termination liability terms and conditions applicable to cancellation or partial disconnection of Centrex Service.

<sup>4</sup> If the number of lines in service drops below the minimum number of lines agreed to in the term commitment plan, the rate will default to the rate applicable for the actual number of lines in service within that term plan.

<sup>5</sup> If the number of lines in service drops below the minimum number of lines available in the 60 month term commitment plan, the rate will default to the rate applicable for the actual number of lines in service within the 36 month term plan. The length of the term plan will remain at 60 months.

Effective: April 1, 2016

CENTREX SERVICE

II. RATES AND CHARGES (Continued)

D. MULTILOCATION CENTREX SERVICE (Continued)

2. PORTABLE EXTENSION DIALING PLAN

	Nonrecurring Charge <sup>1</sup>	Monthly Rate Per Customer <sup>2</sup>
<u>Service Establishment</u> - (Per Customer)		
2 - 25 Lines	\$150.00	
26 - 50 Lines	175.00	
51 - 100 Lines	205.00	
101 + Lines	250.00	
 <u>Month-to-Month</u>		
2 - 25 Lines		\$50.00
26 - 50 Lines		65.00
51 - 100 Lines		125.00
101 + Lines		150.00
 <u>12 Month Term</u> <sup>3,4</sup>		
2 - 25 Lines		35.00
26 - 50 Lines		50.00
51 - 100 Lines		100.00
101 + Lines		125.00
 <u>36 Month Term</u> <sup>3,4</sup>		
2 - 25 Lines		25.00
26 - 50 Lines		35.00
51 - 100 Lines		75.00
101 + Lines		100.00
 <u>60 Month Term</u> <sup>3,4,5</sup>		
51 - 100 Lines		50.00
101 + Lines		75.00
 Additions or Changes		
(a) Addition or Change - per Location	5.00	
(b) Addition or Change - per Change to Dialing Plan		
First 25 Numbers	55.00	
Each Add'l Number	1.00	

<sup>1</sup> In addition to appropriate Nonrecurring Charges in Section 3 of this Product Guide.

<sup>2</sup> In addition to monthly rates for the Primary Station Line in this Product Guide.

<sup>3</sup> See Special Condition W. in this Section for termination liability terms and conditions applicable to cancellation or partial disconnection of Centrex Service.

<sup>4</sup> If the number of lines in service drops below the minimum number of lines agreed to in the term commitment plan, the rate will default to the rate applicable for the actual number of lines in service within that term plan.

<sup>5</sup> If the number of lines in service drops below the minimum number of lines available in the 60 month term commitment plan, the rate will default to the rate applicable for the actual number of lines in service within the 36 month term plan. The length of the term plan will remain at 60 months.

Effective: April 1, 2016

CENTREX SERVICE

II. RATES AND CHARGES (Continued)

D. MULTILOCATION CENTREX SERVICE (Continued)

3. INTERCOM CALLING

	Monthly Rate <u>Per Line</u> <sup>1</sup>
<u>Month-to-Month</u> <sup>2</sup>	
2 - 25 Lines	\$2.75
26 - 50 Lines	2.50
51 - 100 Lines	2.25
101 + Lines	2.00
<u>12 Month Term</u> <sup>2, 4, 5</sup>	
2 - 25 Lines	2.50
26 - 50 Lines	2.25
51 - 100 Lines	2.00
101 + Lines	1.75
<u>36 Month Term</u> <sup>2, 4, 5</sup>	
2 - 25 Lines	2.25
26 - 50 Lines	2.00
51 - 100 Lines	1.75
101+ Lines	1.50
<u>60 Month Term</u> <sup>2, 4, 5, 6</sup>	
51 - 100 Lines	1.50
101 + Lines	1.25
<u>Flat Rate Plan</u> <sup>3</sup>	
per line	10.15

<sup>1</sup> In addition to monthly rates for the Primary Station Line.

<sup>2</sup> Local Measured Service rates are applicable for Intercom calling between customer locations.

<sup>3</sup> Available where facilities and conditions permit. Subscriber locations served by other Local Exchange Carriers are not supported at this time.

<sup>4</sup> See Special Condition W. in this Section for termination liability terms and conditions applicable to cancellation or partial disconnection of Centrex Service.

<sup>5</sup> If the number of lines in service drops below the minimum number of lines agreed to in the term commitment plan, the rate will default to the rate applicable for the actual number of lines in service within that term plan.

<sup>6</sup> If the number of lines in service drops below the minimum number of lines available in the 60 month term commitment plan, the rate will default to the rate applicable for the actual number of lines in service within the 36 month term plan. The length of the term plan will remain at 60 months.

Effective: April 22, 2024

CENTREX SERVICE

II. RATES AND CHARGES (Continued)

D. MULTILOCATION CENTREX SERVICE (Continued)

4. ACCESS TO PRIVATE FACILITIES

	<u>Nonrecurring Charge</u>	<u>Monthly Rate</u>
<u>Access</u> <sup>1,2</sup>		
Month-to Month	\$320.00	\$65.00
12 Month Term	160.00	60.00
36 Month Term	55.00	55.00
60 Month Term	35.00	50.00
84 Month Term	25.00	45.00
 Additions or Changes		
Subsequent additions or changes of access codes, per access code	90.00	n/a

5. WORK-AT-HOME <sup>1</sup>

Per Employee Telephone Line Equipped	50.00	5.00
--------------------------------------	-------	------

E. CENTREX COMMUNICATIONS SYSTEM SERVICE

1. CENTREX COMMUNICATIONS SYSTEM BASIC SERVICE

	<u>Monthly Rate</u>		<u>24-Month Term Rate</u> <sup>5</sup>	<u>24-Month Term Rate</u> <sup>6</sup>	<u>36-Month Term Rate</u> <sup>6</sup>
Basic Service, each line <sup>3,4</sup>	\$51.10	(I)	\$31.95	\$31.95	\$31.95

Includes the following Basic Standard Features:

- Call Transfer (All Calls)
- Call Hold
- Consultation Hold
- Intercom Dialing
- Three Way Calling
- Distinctive Ringing (Inside/Outside)
- Assume Dial "9"

<sup>1</sup> Available where facilities and conditions permit. Subscriber locations served by other Local Exchange Carriers are not supported at this time.

<sup>2</sup> These rates are in addition to applicable rates for the private facility.

<sup>3</sup> Centrex Communications System Basic Service includes a network access line with Touch Tone and Direct Inward/Outward Dialing capability.

<sup>4</sup> See Section 4 for applicable measured usage rates.

<sup>5</sup> Effective 4/26/08, Communications System 2 Year Term service will no longer be available in CA. Existing Communications System customers with 2-year term agreements, with expiration dates through 4/25/10 will be grandfathered.

<sup>6</sup> Effective May 28, 2019, Communications System 2 Year and 3 Year Term service is grandfathered and limited to existing customers at existing locations.

Effective: April 1, 2016

---

CENTREX SERVICE

II. RATES AND CHARGES (Continued)

E. CENTREX COMMUNICATIONS SYSTEM SERVICE (Continued)

2. CENTREX COMMUNICATIONS SYSTEM SELECTABLE FEATURES <sup>2</sup>

	<u>Monthly Rate</u>
Automatic Callback (within system only)	--
Call Forwarding - Busy - Fixed	--
Call Forwarding - No Answer - Fixed	--
Call Forwarding (All Calls)	--
Call Restriction Options: <sup>1</sup>	
No Call Restrictions	--
Call Restriction One	--
Call Restriction Two	--
Call Restriction Three	--
Call Restriction Four	--
Call Restriction Five	--
Call Restriction Six	--
Call Restriction Seven	--
Call Waiting/Cancel Call Waiting	--
Dial Call Waiting-Originating	--
Call Pick-Up Directed	--
Call Pick-Up Group	--
Hunting Series	--
Hunting Multi-Line	--
Speed Dialing	--

<sup>1</sup> These call restrictions are specific to Centrex Communications System Service.

<sup>2</sup> Some of these features are not available for certain switch types.

Effective: April 1, 2016

CENTREX SERVICE

II. RATES AND CHARGES (Continued)

E. CENTREX COMMUNICATIONS SYSTEM SERVICE (Continued)

3. CENTREX COMMUNICATIONS SYSTEM OPTIONAL FEATURES <sup>4</sup>

	<u>Additional MRC Per Month</u>
Busy Redial	\$5.00
Call Block (*60)	3.00
Call Park	3.00
Call Park Directed	4.00
*69	5.00
Caller ID - Number Only	6.00
Caller ID	7.00
Executive Busy Override	4.00
Last Number Redial <sup>1</sup>	4.00
Select Call Forwarding	5.00
Priority Call	3.00

Additional features and feature packages available from other Product Guide sections include:

Call Trace <sup>2</sup>	--
Enhanced Call Forwarding - Existing Number <sup>2</sup>	--
Enhanced Call Forwarding - Existing Number w/Call Manager <sup>2</sup>	--
Voice Messaging <sup>3</sup>	--
Unlimited Local and Toll Usage for Business Feature Package Two A <sup>2</sup>	--
Unlimited Local and Toll Usage for Business Feature Package Three <sup>2</sup>	--

4. OPTIONAL PREFIX SERVICE CHARGES

When the Centrex Communications System station line is located in a different central office area of the serving exchange at the customer's request, the Optional Prefix Service Charge applies as specified in Section 6 of this Product Guide in addition to the line rate for Centrex Communications System Basic Service.

<sup>1</sup> This feature is specific to Centrex Communications System Service.

<sup>2</sup> See Section 7 and 8 of this Product Guide for the rates and descriptions of these services.

<sup>3</sup> See Section 6 of this Product Guide for the rates and description of Voice Messaging.

<sup>4</sup> Some of these features are not available for certain switch types.

Effective: April 1, 2016

---

CENTREX SERVICE

II. RATES AND CHARGES (Continued)

E. CENTREX COMMUNICATIONS SYSTEM SERVICE (Continued)

5. USAGE CHARGES

No local calling usage allowance is included in the Centrex Communications System message or measured rate schedule. Usage charges apply as specified in Section 4 of this Product Guide.

6. SERVICE CHARGES

The following Service Order Activity Charges are applicable:

Subsequent Order Moves and Changes Charge, per Section 3 of this Product Guide  
Outside Facility Connection Charge, per Section 3 of this Product Guide  
Installed Primary Station Line Charge, per Section 11 of this Product Guide  
Minor Software Change Charge, per Section 11 of this Product Guide

If a customer elects to change from a business line or another Centrex service to the Centrex Communications System Service or from the Centrex Communications System Service to another Centrex service, a Subsequent Order Moves and Changes charge applies.

No service order charges will apply for Centrex Communications System Custom Calling and CLASS Services, if installed initially with the Centrex Communications System. When features are added or rearranged on an existing line subsequent to the installation of the Centrex Communications System, the appropriate Subsequent Order Moves and Changes charge and the Minor Software Change charge will apply.

The Subsequent Order Moves and Changes charge and the Installed Primary Station Line charge will not be assessed to customers who subscribe to Centrex Communications System term commitment plans as found in this Product Guide.

7. FOREIGN EXCHANGE SERVICE

Foreign Exchange Service must be applied to the entire Centrex Communications System business group. Rates and charges are applied as specified in Section 6 of this Product Guide.

8. CALLING PLANS

A Centrex Communications System customer is eligible for a Local Calling Plan. A Centrex Communications System customer is also eligible for a toll Discount Calling Plan. See Section 19 of this Product Guide for descriptions and rates of the Local Calling Plans and the Discount Calling Plans.



Effective: April 1, 2016

---

PRIVATE BRANCH EXCHANGE SERVICE

TABLE OF CONTENTS

	<u>SHEET NO.</u>
I. GENERAL	1
II. SPECIAL CONDITIONS	
A. Inward Dialing Service - DID (AE - SXS 301 Type Equipment)	1
B. Centrex Service (AE - SXS 311 Type Equipment)	3
C. Supplemental Services Arrangement – Applicable to More Than One Type PBX	7
III. RATES AND CHARGES	
A. Inward Dialing Service - DID (AE - SXS 301 Type Equipment)	9
B. Centrex Service (AE - SXS 311 Type Equipment)	10
C. Supplemental Services Arrangement – Applicable to More Than One Type PBX	13
D. Dial PBX	14

Effective: April 1, 2016

---

PRIVATE BRANCH EXCHANGE SERVICE

I. GENERAL

Applicability

Applicable to network services of Centrex and Direct Inward Dialing and subject to the constraints of the Company's Product Guide.

Territory

Within the exchange areas of all exchanges as said areas are defined on maps as part of this Product Guide.

II. SPECIAL CONDITIONS

A. INWARD DIALING SERVICE - DID (AE - SXS 301 Type Equipment)

1. Stations (Maximum - Unlimited)

Attendant recall  
Conference - 2 stations & 1 trunk  
Consultation - hold  
Controlled transfer  
Direct outward dialing to trunks, tie lines <sup>1</sup>, or private lines <sup>1</sup>

Service groups - 3 classes  
Station dialing  
Restriction (restricted, semirestricted or nonrestricted)  
Universal night answering access

2. System

Code restriction (level access denial by station or groups of stations)  
Direct Inward Dialing to stations  
Night answering - Universal or predetermined  
Standby power  
Standby signaling  
Station group hunting - sequential  
Trunk groups - unlimited

3. Capacity and Limitations

a. Common Equipment

- (1) This is a step-by-step (SXS) rack mounted system, with unlimited capacities for station lines, trunks and intercommunicating paths and trunk groups limited only by selector access availability.
- (2) This system is provided by the Company in accordance with the Company's operating conditions and engineering standards, where operating conditions and facilities permit.

<sup>1</sup> When system is so arranged

Effective: April 1, 2016

---

PRIVATE BRANCH EXCHANGE SERVICE

II. SPECIAL CONDITIONS (Continued)

A. INWARD DIALING SERVICE - DID (AE - SXS 301 Type Equipment) (Continued)

4. Switching System Line

- a. The rates include switch arrangement and trunk line facilities except foreign exchange trunk line facilities necessary to furnish basic features of DID service.
- b. The switching system line rate, whether restricted, semi restricted or nonrestricted will be computed by adding the rates for Intrasystem Service and direct inward and outward dialing features.
- c. The above rate treatment for direct inward and outward dialing is applicable only when the Intrasystem Service is provided by the Company and is not applicable in conjunction with customer-provided Intrasystem facilities.

5. Supplemental Services Arrangement

Arrangement to provide full denial service will be furnished where the customer desires to deny access to toll and zone calling areas on in-service central office trunks. The charges and rates for this service are in addition to the applicable trunk service connection charge and monthly rate and contemplate station, operator, tie line or private line access to a trunk or trunk group.

Metering arrangements to mechanically record each outgoing local exchange call from a station line, tie line or private line will be provided only in connection with a full line so arranged. Central office metering arrangements will be provided in accordance with the charges, rates and special conditions in Section 6 of this Product Guide.

Full toll denial service will only be provided where the serving ("dial tone") central office and the customer are in exchanges serviced by this Company.

On any DID system for which message waiting or metering service is provided where stations access a trunk(s) arranged for full denial service, the capability to transfer a trunk call (outgoing) to another station will not be provided.

When an attempt is being made to place a toll or zone calling call in calling areas which are denied, the call will be diverted to a recording and not to an operator of the customer or the Company. This is the function of the toll denial trunk, not the DID system.

The arrangement will permit access only to the Traffic Service Position System (TSPS) toll operator and the arrangement that will deny access to toll and/or zone calling prefixes but will permit access to the Traffic Service Position System (TSPS) toll operator will only be available where the serving central office is arranged to access the traffic service position system network.

Selective access to certain customer-designated telephone, prefixes (or codes) will be provided, where compatible, in connection with local and foreign exchange trunks or private lines which terminate on the mechanical arrangements of DID systems.

PRIVATE BRANCH EXCHANGE SERVICE

II. SPECIAL CONDITIONS (Continued)

A. INWARD DIALING SERVICE - DID (AE - SXS 301 Type Equipment) (Continued)

5. Supplemental Services Arrangement (Continued)

This arrangement will prevent access to certain telephone prefixes (or codes), while allowing calling of other telephone prefixes (or codes), at the discretion of the customer, subject to the limitations of the arrangement.

Local and foreign exchange trunks or private lines may be provided with access to different preselected dialing prefixes within the same system on different groups or stations. A separate selective arrangement is required for each group of preselected dialing prefixes.

Each station arranged for the universal nonrestriction feature may access all trunks or private line associated with the DID system irrespective of the selective arrangements applicable to each trunk or private line.

Changes in, rearrangements of, or additions to, nonrestricted prefixes caused by Company-initiated telephone prefix (or code) changes will be made by the Company at no charge to the customer. All other changes or rearrangements made at the customer's request will be made at the appropriate charge specified herein.

B. CENTREX SERVICE (AE - SXS 311 Type Equipment)

1. Stations (Maximum - Unlimited)

Attendant Recall on operator handled calls  
Conference - 2 stations and trunk  
Consultation - hold  
Controlled transfer  
Direct Outward Dialing to trunks, tie lines 1, or private lines <sup>1</sup>  
Distinctive ringing (identifies whether local or incoming call)  
Immediate ring  
Nuisance trap (provides for "hold and trace" within the centrex system)  
Service group - 3 classes  
Station Dialing  
Restriction: Restricted, semirestricted or nonrestricted  
Universal night answering access

2. System

Automatic number identification of outward traffic  
Code restriction (level access denial by station or groups of stations)  
Direct Inward Dialing to stations  
Intercept of unassigned terminals (provided in accordance with operating procedures and standards of the Company)  
Night answering - Universal or predetermined Standby power  
Standby signaling  
Station group hunting - sequential (10 stations max.)  
Trunk groups - unlimited

<sup>1</sup> When so arranged

Effective: April 1, 2016

---

PRIVATE BRANCH EXCHANGE SERVICE

II. SPECIAL CONDITIONS (Continued)

B. CENTREX SERVICE (AE - SXS 311 Type Equipment) (Continued)

3. Capacity and Limitations

a. Common Equipment

- (1) This is a step-by-step (SXS) rack mounted system, with unlimited capacities for station lines, trunks and intercommunicating paths with trunk groups limited only by selector access availability.
- (2) The rates and charges set forth in this Section contemplate the provision of service under average installation conditions, in keeping with established standards of the Company and the availability of appropriate facilities. If unusual installation costs are involved, the Company may decline the provision of service or require the customer to pay all or a portion of such costs, the amount depending on whether the revenue to be derived from the service is sufficient to warrant the Company assuming such costs. The amount of such additional installation costs will depend on the circumstances in each case and charges to the customer are subject to prior authorization by the Public Utilities Commission.
- (3) In addition to the basic service features, Centrex Service includes detail billing of toll traffic, and optional bulk or detail billing of zone calling traffic or local calls in a measured rate area (central office located centrex only) by station line number.

b. Primary Line

- (1) The primary line rate, whether restricted, semirestricted or nonrestricted will be computed by adding the rates for Intrasystem service and direct inward and outward dialing with automatic number identification of outward traffic.

The above rate treatment for direct inward and outward dialing feature is applicable only when the Intrasystem Service is provided by the Company and is not applicable in conjunction with customer-provided intrasystem facilities.

- (2) The rates for primary lines include the switch arrangement and trunk line facilities except foreign exchange trunk line facilities necessary to furnish the basic features of Centrex service.

c. Two Digit Dialing Arrangement

- (1) The rates and charges herein do not include access arrangements or other charges and rates.
- (2) When required by the customer, a uniform dialing arrangement can also be provided by means of wiring options within the Centrex system.

The rate and charge applicable for this service will be the same as that applicable to the charge for the restrictive status of a station and will be required for each dialing pattern on a line.

Effective: April 1, 2016

---

PRIVATE BRANCH EXCHANGE SERVICE

II. SPECIAL CONDITIONS (Continued)

B. CENTREX SERVICE (AE - SXS 311 Type Equipment) (Continued)

3. Capacity and Limitations (Continued)

- d. Arrangement to provide full denial service will be furnished where the customer desires to deny access to all toll and zone calling areas on in-service central office trunks. The charges and rates for the service are in addition to the applicable trunk service connection charge and monthly rate and contemplate station, operator, tie line or private line access to a trunk or trunk group.

Metering arrangements to mechanically record each outgoing local exchange call from a station line, tie line or private line will be provided only in connection with a full denial arrangement. One meter arrangement is required for each line so arranged. Central office metering arrangements will be provided in accordance with the charges, rates and special conditions in Section 6 of this Product Guide.

Full toll denial service will only be provided where the serving ("dial tone") central office and the customer are in exchanges served by this Company.

On any system for which message waiting or metering service is provided where stations access a trunk(s) (or access line to the central office) arranged for full denial service, the capability to transfer a trunk call (outgoing) to another station will not be provided.

When an attempt is being made to place a toll or zone calling call in calling areas which are denied, the call will be diverted to a recording and not to an operator of the customer or the Company. This is a function of the toll denial trunk, not the Centrex System.

The arrangement that will permit access only to the traffic service position system toll operator and the arrangement that will deny access to toll and/or zone calling prefixes but will permit access to the traffic service position system toll operator will only be available where the serving central office is arranged to access the traffic service position system network.

When private line services terminating on the Centrex System are arranged to provide direct dial access to the local exchange service, such service will be provided via dedicated trunks and these trunks may be equipped to deny access to toll and zone calling areas. The rate and charge for toll denial on these dedicated local trunks will be the same as for foreign exchange trunks set forth under Rates herein. Rates and charges for access arrangements, trunks, and toll denial service are applicable.

Effective: April 1, 2016

---

PRIVATE BRANCH EXCHANGE SERVICE

III. SPECIAL CONDITIONS (Continued)

B. CENTREX SERVICE (AE - SXS 311 Type Equipment) (Continued)

3. Capacity and Limitations (Continued)

- e. Selective access to certain customer-designated telephone prefixes (or codes) will be provided, where compatible, in connection with local and foreign exchange trunks or private lines which terminate on the mechanical arrangements of systems.

This arrangement will prevent access to certain telephone prefixes (or codes), while allowing calling of other telephone prefixes (or codes), at the discretion of the customer, subject to the limitations of the arrangement.

Local and foreign exchange trunks or private lines may be provided with access to different preselected dialing prefixes within the same system on different groups of stations. A separate selective arrangement is required for each group of preselected dialing prefixes.

Changes in, rearrangements of, or additions to, nonrestricted prefixes caused by Company-initiated telephone prefix (or-code) changes will be made by the Company at no charge to the customer. All other changes or rearrangements made at the customer's request will be made at the appropriate change charge specified herein.

- f. Rotary out-trunk selection arrangement: Permits the customer to maintain the same outgoing call volume, and may utilize fewer trunks or circuits by providing switching equipment which will automatically search all trunks or circuits of a specific group and seize the first idle trunk or circuit available.

(1) This service arrangement is limited to foreign exchange trunks and private line channels.

(2) All trunks or channels assigned to rotary selection arrangement must be on the same type, grade, and class of service and must have the same point-to-point terminations. Mixtures of service would defeat the purpose of this service arrangement.

(3) Private line channels with different alternate-use arrangements, or having different transmission capabilities may not be associated with the same selection arrangement.

(4) Rearrangement of trunks or channels from one selection arrangement to another, due to change in type, grade, or class of service, or points of termination, will be made at the nonrecurring charge for installation of a new trunk or channel.

- g. When a central office that furnished Centrex Service is converted to common control switching equipment, existing Centrex Service customers will be notified of the planned conversion a minimum of one year in advance and will be required to terminate the Centrex Service within two years after the central Office is converted. Centrex service furnished during the two year service limitation period will continue to be offered under III. Rates and Charges.

Effective: April 1, 2016

---

PRIVATE BRANCH EXCHANGE SERVICE

II. SPECIAL CONDITIONS (Continued)

C. SUPPLEMENTAL SERVICES ARRANGEMENT – APPLICABLE TO MORE THAN ONE TYPE PBX

1. Rotary trunk control is an arrangement whereby a customer may stop the rotary action at a predetermined trunk or line to control a selected group of trunk lines or station lines (Centrex service) by the operation of customer equipment at the customer's premises. The arrangement is permanently connected in the central office to the trunk selected to control the rotary stop function. Trunks or lines beyond the "stop" point may be utilized for night connections. Mileage charges as set forth in Private Line Schedules apply to the channel between the customer premises and the central office.
2. Arrangement to provide full denial service will be furnished where the customer desires to deny access to all toll and zone calling areas on in-service central office trunks. The charges and rates for this service are in addition to the applicable trunk service connection charge and monthly rate and contemplate station, operator, tie line or private line access to a trunk or trunk group.

Metering arrangements to mechanically record each outgoing local exchange call from a station line, tie line or private line will be provided only in connection with a full denial arrangement. One meter arrangement is required for each line so arranged. Metering arrangements will be provided in accordance with the charges, rates and special conditions in Section 6 of this Product Guide.

Full toll denial service will only be provided where the serving ("dial tone") central office and the customer are in exchanges serviced by this Company.

On the cord type expandable dial PBX system, for which message waiting or metering service is provided where stations access a trunk(s) arranged for full denial service, the capability to transfer a trunk call (outgoing) to another station will not be provided.

When an attempt is being made to place a toll or zone calling call in calling areas which are denied, the call will be diverted to a recording and not to an operator of the customer or the Company. This is the function of the toll denial trunk, not the PBX.

The arrangement that will permit access only to the traffic service position system toll operator and the arrangement that will deny access to toll and/or zone calling prefixes, but will permit access to the traffic service position system toll operator, will only be available where the serving central office is arranged to access the traffic service position system network.



Effective: April 1, 2016

---

PRIVATE BRANCH EXCHANGE SERVICE

II. SPECIAL CONDITIONS (Continued)

C. SUPPLEMENTAL SERVICES ARRANGEMENT – APPLICABLE TO MORE THAN ONE TYPE PBX (Continued)

3. Selective access to certain customer-designated telephone prefixes (or codes) will be provided, where compatible, in connection with local and foreign exchange trunks or private lines which terminate on the mechanical arrangements of PBX systems.

This arrangement will prevent access to certain telephone prefixes (or codes) while allowing talking of other telephone prefixes (or codes), at the discretion of the customer, subject to the limitations of the arrangement.

Local and foreign exchange trunks or private lines may be provided with access to different preselected dialing prefixes within the same system on different groups of stations. A separate selective arrangement is required for each group of preselected dialing prefixes.

Each station arranged for the universal nonrestriction feature may access all trunks or private lines associated with the PBX system irrespective of the selective arrangements applicable to each trunk or private line.

Changes in, rearrangements of, or additions to, nonrestricted prefixes caused by Company-initiated telephone prefix (or code) changes will be made by the Company at no charge to the customer. All other changes or rearrangements made at the customer's request will be made at the appropriate charge specified in Section 3 of this Product Guide.

Effective: April 1, 2016

PRIVATE BRANCH EXCHANGE SERVICE

III. RATES AND CHARGES

A. INWARD DIALING SERVICE - DID <sup>1</sup>  
(AE - SXS 301 Type Equipment)

	<u>Nonrecurring Charge</u>	<u>Monthly Rate</u>
1. Switching System Line (restricted, semi restricted and nonrestricted -		
a. Switching System - Capacity Unlimited		
(1) Flat Rate Service		
(a) Intrasystem Service		
First 400 lines of switching equipment	-	\$3,490.00
Each additional 100 lines of switching	-	825.00
(b) Direct Inward and Outward Dialing Feature		
First 400 lines of switching equipment	-	1,915.00
Each additional 100 lines of switching equipment	-	225.00
(2) Message or Measured Rate Service - See Section 4 of this Product Guide for Special Conditions and message or exchange unit charges and exchanges where offered - (message or exchange unit allowance - none)		
	<u>Basic Termination Charge</u>	
(a) Intrasystem Service		
First 400 lines of switching equipment	-	3,490.00
Each additional 100 lines of switching equipment	-	825.00
(b) Direct Inward and Outward Dialing Feature		
First 400 lines of switching equipment	-	1,072.50
Each additional 100 lines of switching equipment	-	315.00
b. Installed Line Capacity (flat, message or measured rate services)		
First 400 lines	-	\$6,600.00
Each additional 100 lines	-	1,650.00
c. Per Installed Primary Line Capacity, each line	\$77.00 <sup>2</sup>	

<sup>1</sup> Offering limited to services established prior to November 21, 1979.

<sup>2</sup> \$70.00 prior to April 7, 1980 - \$77.00 after April 7, 1980.

Effective: April 1, 2016

PRIVATE BRANCH EXCHANGE SERVICE

III. RATES AND CHARGES (Continued)

A. INWARD DIALING SERVICE - DID <sup>1</sup> (Continued)  
 (AE - SXS 301 Type Equipment)

2. Supplemental Services

	<u>Nonrecurring Charge</u>	<u>Monthly Rate</u>
b. Toll and Zone Calling Denial Service and arrangement to permit access to the Traffic Service Position System (TSPS) toll operator		
(1) Arrangement to deny access to toll and/or zone calling prefixes only		
(2) Arrangement to permit access only to the traffic service position position system toll operator		
(3) Arrangement that will deny access to toll and/or zone calling prefixes but will permit access to the traffic service position system toll operator		
(4) The following charges and rates apply to any one of the above arrangements		
(a) Local Exchange Service		
First 20 or less station lines arranged	\$154.00	\$11.00
Each additional station line arranged	.95	.15
(b) Foreign Exchange Service		
Each trunk arranged <sup>2</sup>	110.00	6.00

B. CENTREX SERVICE - (AE-SXS 311 Type Equipment)

Applicable to Centrex Service furnished to a business customer exclusive of hotel type

(Service availability) <sup>1</sup>

1. Primary Line  
 Rates apply to restricted, semirestricted and nonrestricted

a. Working Primary Lines - Flat Rate Service

(1) Intrasystem Service

First 200 or less lines <sup>1</sup>	-	1,684.50
Each additional line	-	7.55

<sup>1</sup> Offering limited to services established prior to November 21, 1979.

<sup>2</sup> Plus applicable trunk rate and service connection charge.

Effective: April 1, 2016

PRIVATE BRANCH EXCHANGE SERVICE

III. RATES AND CHARGES (Continued)

B. CENTREX SERVICE - (AE-SXS 311 Type Equipment) (Continued)

1. Primary Line (Continued)

a. Working Primary Lines - Flat Rate Service (Continued)

	<u>Monthly Rate</u>
(b) Direct Inward and Outward Dialing with automatic number identification of outward traffic	
First 200 or less lines <sup>2</sup>	\$2,687.00
Each additional line	6.10

(2) Measured Rate Service - See Section 4 of this Product Guide for Special Conditions and exchange unit charges and exchanges where offered - (exchange unit allowance -0)

(a) Intrasystem Service

First 200 or less lines <sup>1</sup>	1,684.50
Each additional line	7.55

(b) Direct Inward and Outward dialing with automatic number identification of outward traffic

First 200 or less lines <sup>1</sup>	1,497.00
Each additional line	4.60

	<u>Basic Termination Charge</u>	<u>Nonrecurring Charge</u>	
b. Installed Line Capacity <sup>1</sup>			
(1) First 200 or less lines <sup>1</sup>	-	\$4,810.00	-
(2) Each additional line <sup>2</sup>	-	24.05	-
c. Per Installed Line Capacity	\$99.00	-	-

<sup>1</sup> Minimum additions will be in increments of 200.

<sup>2</sup> Offering limited to service established prior to November 21, 1979. Changes in line capacity (subject to equipment availability) are permitted.

PRIVATE BRANCH EXCHANGE SERVICE

III. RATES AND CHARGES (Continued)

B. CENTREX SERVICE - (AE-SXS 311 Type Equipment) (Continued)

2. Supplemental Services

	<u>Nonrecurring Charge</u>	<u>Monthly Rate</u>
a. Toll and Zone Calling Denial Service and arrangement to permit access to the Traffic Service Position System (TSPS) toll operator		
(1) Arrangement to deny access to toll and/or zone calling prefixes only		-
(2) Arrangement to permit access only to the Traffic Service Position System toll operator		-
(3) Arrangement that will deny access to toll and/or zone calling prefixes but will permit access to the Traffic Service Position System toll operator		-
(4) The following charges and rates apply to any one of the above arrangements:		
(a) Local Exchange Service		
First 20 or less lines arranged	\$154.00	\$13.75
Each additional line arranged	.95	.20
(b) Foreign Exchange Service		
Each trunk arranged	77.00	6.90
b. Toll Denial Service - <u>Selective</u> . Permits access only to certain preselected dialing prefixes, including toll and/or zone calling. Access to all other prefixes is denied.		
(1) Local Exchange Service		
(a) First 100 or less lines	605.00	192.50
(b) Each additional line	1.10	.40
c. Touch Calling Service		
(1) Service arranged in line groups for 200 station		
Each line group arranged	473.00	206.25

Effective: April 1, 2016

PRIVATE BRANCH EXCHANGE SERVICE

III. RATES AND CHARGES (Continued)

B. CENTREX SERVICE - (AE-SXS 311 Type Equipment) (Continued)

2. Supplemental Services (Continued)

	<u>Nonrecurring Charge</u>	<u>Monthly Rate</u>
d. Common arrangement for two-digit access to special services (capacity 10 access paths)	\$385.00	\$46.75
Each access path arranged <sup>1</sup>	99.00	14.80

C. SUPPLEMENTAL SERVICE ARRANGEMENT - APPLICABLE TO MORE THAN ONE TYPE PBX

1. Rotary Trunk (Line) control arrangement, each unit	27.50	4.15
2. Toll and Zone Calling Denial Service and arrangement to permit access to the Traffic Service Position System (TSPS) toll operator		
a. Arrangement to deny access to toll and/or zone calling prefixes only	TSPS-LOC NON TSPS-LOC FX	
b. Arrangement to permit access only to the Traffic Service Position System (TSPS) toll operator		
c. Arrangement that will deny access to toll and/or zone calling prefixes but will permit access to the Traffic Service Position System (TSPS) toll operator		

Local trunks and/or foreign exchange trunks arranged with any one of the above arrangements, each trunk arranged <sup>2</sup>	110.00	9.00
---	--------	------

Not applicable to Direct Inward Dialing, Centrex or EBSS services.

<sup>1</sup> Centrex line rate will not be applicable to two-digit access but may be applicable to access special service features.

<sup>2</sup> Plus applicable trunk rate.

Effective: April 1, 2016

PRIVATE BRANCH EXCHANGE SERVICE

III. RATES AND CHARGES (Continued)

C. SUPPLEMENTAL SERVICE ARRANGEMENT - APPLICABLE TO MORE THAN ONE TYPE PBX (Continued)

	<u>Nonrecurring Charge</u>	<u>Monthly Rate</u>
3. Toll Denial Service - <u>Selective</u> . Permits access only to certain preselected dialing prefixes, including toll and/or zone calling. Access to all other prefixes is denied.		
a. Each arrangement or preselected dialing prefixes		
1st 10 or less trunks or lines so arranged	\$1,300.00	\$292.50
Each additional trunk or line so arranged	90.00	11.25
b. Intercept trunk, each	140.00	7.00
c. Recorder-announcer, each	200.00	30.40

D. DIAL PBX

Dial Private Branch Exchange Service within the Kenwood, Los Gatos, Novato and Morgan Hill Exchanges.

		<u>Installation Charge</u>	<u>Monthly Rate</u>
1. Direct Inward Dialing Service <sup>3</sup>			
Equipment for each direct inward dialing trunk		-	\$9.90
2. Toll Diverting Service <sup>3</sup>			
a. Equipment to deny station dial access to all toll calling areas			
Each trunk equipped		\$31.00	6.35
	Basic Termination <u>Charge</u>		
3. Automatic Number Identification Service (ANI) <sup>3</sup>			
a. Each ANI trunk connected	\$400.00	121.00	17.05
b. Station detection equipment <sup>4</sup>			
First 100 stations	1,500.00	1,650.00	110.00
Each additional 100 station groups installed	500.00	121.00	15.40

<sup>1</sup> Plus applicable trunk rate.

<sup>2</sup> Will not be regularly offered for new installation on or after December 13, 1978 but will be furnished when systems on hand become available for reuse.

<sup>3</sup> Available only for large central office type systems.

<sup>4</sup> In addition to station rates.

Effective: April 1, 2016

---

INTEGRATED SERVICES DIGITAL NETWORK (SDN) - PRIMARY RATE INTERFACE (PRI) /  
BASIC RATE INTERFACE (BRI)

TABLE OF CONTENTS

	<u>SHEET NO.</u>
 INTEGRATED SERVICES DIGITAL NETWORK (ISDN) – PRIMARY RATE INTERFACE (PRI) / BASIC RATE INTERFACE (BRI)	
I. GENERAL	
Applicability	1
Territory	1
II. RATES AND CHARGES	
A. ISDN-Basic Rate Interface Services	1
B. ISDN-Primary Rate Interface Services	4
C. Digital (ISDN) Single Line Services	12
III. SPECIAL CONDITIONS	
A. Definitions	13
B. Description of Services	15
C. General	30
D. ISDN-Basic Rate Interface (BRI) Services	31
E. ISDN-Primary Rate Interface (PRI) Services	34
F. Digital (ISDN) Single Line Services	39
G. Discounts for Qualifying Entities	39
 INTEGRATED SERVICES DIGITAL NETWORK (ISDN) – PRIMARY RATE INTERFACE (PRI) BUNDLED SERVICE	
I. GENERAL	40
II. APPLICABILITY	40
III. TERRITORY	40
IV. RATES AND CHARGES	40
V. SPECIAL CONDITIONS	41



Effective: January 15, 2024

INTEGRATED SERVICES DIGITAL NETWORK (SDN) - PRIMARY RATE INTERFACE (PRI) /  
BASIC RATE INTERFACE (BRI)

I. GENERAL

APPLICABILITY

Applicable to network services provided in accordance with Integrated Services Digital Network (ISDN) standards.

TERRITORY

Within all exchange areas as those areas are defined by maps filed as part of this Product Guide.

II. RATES AND CHARGES

A. ISDN-BASIC RATE INTERFACE SERVICES\* 1  
(See Minimum Service Requirement in SPECIAL CONDITIONS)

	<u>Nonrecurring Charges</u>	<u>Monthly Rates</u>	
1. Basic Rate Interface Line	2	\$175.92	(I)
2. ISDN Access - Single User	-	\$ 42.24	(I)
3. ISDN Multipoint Access - Multiple User	-	52.80	(I)
4. Central Office Services, per channel			
B Voice	-	2.48	
B Circuit Switched Data (B-CSD) 1	-	36.96	(I)
B Voice/CSD 1	-	42.24	(I)
B Packet, per packet 4, 5, 6	-	132.00	
D Packet, per packet 4, 6	-	5.20	
5. Additional Telephone Numbers, each number	2	.44	

<sup>1</sup> All data calls are measured and usage charges are applicable except data calls within the same customer group. See Section 4 of this Product Guide, Measured Rate Service - Local Calling Rates.

<sup>2</sup> Nonrecurring Charges from Section 3 of this Product Guide (Initial Order, Central Office Activity, Outside Facility Connection, and Subsequent Order charges) for business services are applicable.

<sup>4</sup> See Section 32 of this Product Guide for applicable packet rates.

<sup>5</sup> As of February 13, 2004, this service is available for orders placed for CALEA.

\* Integrated Services Digital Network – Basic Rate Interface is grandfathered and limited to existing customers at existing locations as of March 28, 2022. Moves, additions or changes will not be permitted.

Effective: January 15, 2024

INTEGRATED SERVICES DIGITAL NETWORK (SDN) - PRIMARY RATE INTERFACE (PRI) /  
BASIC RATE INTERFACE (BRI)

II. RATES AND CHARGES (Continued)

A. ISDN - BASIC RATE INTERFACE SERVICES\* (Continued)

6. Package Services

	<u>Nonrecurring Charges</u>	<u>Monthly Rates</u>
Centrex Feature Packages		
Package 1000	-	\$3.00
Package 2000	-	5.00
Package 3000	-	6.00
ISDN Basic Station Service	\$30.00	7.70
ISDN Deluxe Station Service	30.00	9.08
CO Attendant Service	100.00	35.00
Data 1000 <sup>1</sup>	15.00	3.30
Data 2000 <sup>1</sup>	15.00	5.50
Feature Package A <sup>1,4</sup>		5.40
Feature Package B <sup>1,4</sup>		17.99
Feature Package C <sup>1,4</sup>		28.19
Feature Package O <sup>1,4</sup>		2.80

7. Individual Services, Per Channel

Data Direct Connect	--	1.10
Data Closed User Group	--	1.00
6-way Conference	--	9.50

8. Data Base Change - Per hour or portion thereof

\$60.00      --

9. Individual Line Loop Extension<sup>2</sup>

Basic Rate Interface <sup>3</sup>	50.00	147.84	(l)
-----------------------------------	-------	--------	-----

<sup>1</sup> Rates applicable to exchanges listed in Section 5, Sheet 3 of this Product Guide.

<sup>2</sup> These rates apply in addition to the rates for Basic Rate Interface and Single Line Services.

<sup>3</sup> Applies to BRI Single User and Multiple User.

<sup>4</sup> This service is limited to existing customers only.

\* Integrated Services Digital Network – Basic Rate Interface is grandfathered and limited to existing customers at existing locations as of March 28, 2022. Moves, additions or changes will not be permitted.

Effective: March 28, 2022

INTEGRATED SERVICES DIGITAL NETWORK (SDN) - PRIMARY RATE INTERFACE (PRI) /  
BASIC RATE INTERFACE (BRI)

II. RATES AND CHARGES (Continued)

A. ISDN - BASIC RATE INTERFACE SERVICES\* (Continued)

(C)

	<u>Nonrecurring Charge</u>	<u>Monthly Rates</u>
10. Automatic Call Distribution /Management Information System (ACD/MIS)		
a. Basic ACD Feature Package		
per ACD Group	\$55.00	
per ACD Line <sup>1</sup>		\$28.40
Multipoint ACD Line		42.60
b. Advanced ACD/MIS Optional Features		
Additional Queue Slots		
per System	25.00	
per Slot		2.65
Call Prompts, <sup>2</sup>		
per step <sup>3</sup>	100.00	
per step <sup>3</sup>		150.00
Call Vectoring		
per ACD Group	40.00	
per ACD Line		4.00
Direct Agent Access		
per Access Number	N/A	2.00
MIS Data Link		
per link <sup>4</sup>	25.00	
per link <sup>4</sup>		80.00

<sup>1</sup> See Section 4 of this Product Guide for applicable Local Calling Usage Rates.

<sup>2</sup> Customer must subscribe to Call Vectoring to have Call Prompts.

<sup>3</sup> The Nonrecurring charges for Call Prompts apply per step. Each arrangement level is a "step", for example: the first step would ask the customer to press "1" for the Accounting Department or press "2" for Engineering. Once the customer responded to the first prompt, the second step would then ask the customer to press "1" for Cost Accounting, "2" for Disbursement Accounting, and so on.

<sup>4</sup> One MIS Data Link is required for each supervisor's workstation.

\* Integrated Services Digital Network – Basic Rate Interface is grandfathered and limited to existing customers at existing locations as of March 28, 2022. Moves, additions or changes will not be permitted.

(N)  
(N)

Effective: April 1, 2023

INTEGRATED SERVICES DIGITAL NETWORK (SDN) - PRIMARY RATE INTERFACE (PRI) /  
BASIC RATE INTERFACE (BRI)

II. RATES AND CHARGES (Continued)

A. ISDN - BASIC RATE INTERFACE SERVICES\* (Continued)

	<u>Nonrecurring Charge</u>	<u>Monthly Rates</u>
11. Exception Provisioning <sup>1</sup>		
a. Provisioning	\$ -	\$40.00 <sup>2</sup>
b. Special Transport Mileage, per airline mile <sup>3</sup>	-	6.50

B. ISDN-PRIMARY RATE INTERFACE SERVICE

ISDN-PRI Service is available on a month-to-month basis or a term commitment plan of 1, 2, 3 or 5 Years. The minimum subscription period for this service is one month. ISDN-PRI Service can be provided from a customer's serving central office or from an alternative central office. If service is provided from an alternative central office, additional Switched Facility charges as specified in II.Rates and Charges B.1.f or B.2.e will apply.

	<u>Nonrecurring Charge</u>	<u>Monthly Rate</u>
1. <u>Month-to-Month Option</u>		
a. PRI Access Interface, per Central Office Termination	<sup>4</sup>	\$ 826.56 <sup>5</sup> (I)
b. Switched Facility (Customer's Premises to Local Central Office)		
(1) Option 1		
a. PRI DS1 Switched Facility	525.00	310.50
b. Special Transport Termination		30.00
c. Special Transport, per airline mile		11.00
(2) Option 2		
Alternate High Capacity Digital Facilities	<sup>6</sup>	<sup>6</sup>

<sup>1</sup> These rates apply in addition to the rates and charges for Basic Rate Interface Services.

<sup>2</sup> There is no additional charge for Special Transport Termination.

<sup>3</sup> This rate applies on a per line basis.

<sup>4</sup> See Database Configuration, II.Rates and Charges B.1.d.(1) following.

<sup>5</sup> The FCC End User Common Line monthly rate and FCC ISDN Line Port monthly rates are applicable as specified in Frontier Operating Companies Tariff FCC No. 14 and Frontier Operating Companies Tariff FCC No. 13.

<sup>6</sup> DS1, DS3 or any other compatible High Capacity Digital Facility that meets specifications determined by the Utility and offered on a month-to-month basis may be utilized in lieu of the Switched Facility specified in Option 1. See the applicable Tariff, Frontier Operating Companies Tariff FCC No. 14 or Frontier Operating Companies Tariff FCC No. 13, for applicable rates and terms.

\* Integrated Services Digital Network – Basic Rate Interface is grandfathered and limited to existing customers at existing locations as of March 28, 2022. Moves, additions or changes will not be permitted.

Effective: April 1, 2023

INTEGRATED SERVICES DIGITAL NETWORK (SDN) - PRIMARY RATE INTERFACE (PRI) /  
BASIC RATE INTERFACE (BRI)

II. RATES AND CHARGES (Continued)

B. ISDN-PRIMARY RATE INTERFACE SERVICE (Continued)

	<u>Nonrecurring Charge</u>	<u>Monthly Rate</u>	
1. <u>Month-to-Month Option</u> (Continued)			
c. B Channel Configurations			
(1) Circuit Switched Data	1	2	
(2) DID/DOD Service, First telephone number for each channel activated	1	\$6.61	(I)
Additional telephone numbers	1	0.66	(I)
(3) Tie Channel Service to customer premises or Central Office to Central Office, each per "B" Channel	3,4	10.00	
per ISDN-PRI (11+ "B" Channels)		100.00	
(4) Tie Channel to an Intermediary Customer <sup>5</sup> per "B" Channel	3,4	10.00	
per ISDN-PRI (7+ "B" Channels)		100.00	
(5) 800 Service	1	8.00 <sup>6</sup>	
(6) OutWATS Service	1	8.00 <sup>6</sup>	
(7) Call-by-Call Trunk	1	5.00 <sup>6,7</sup>	
d. Database Configuration			
(1) Initial and Subsequent Service Order, PRI Access Interface, each initial order	\$200.00	--	
B Channel, per type on initial orders and per order for subsequent orders	200.00	--	
e. Optional Features			
(1) Calling Line Identification (CLID) with Name, per PRI Access	3	140.51	(I)
(2) Two B Channel Transfer	3	75.00	
(3) PRI Station Detail Billing	--	100.00	

<sup>1</sup> See Database Configuration, B.1.d.(1) above.

<sup>2</sup> See applicable usage rate under Switched Data Service, Section 33, use the DID/DOD service for the channels.

<sup>3</sup> Nonrecurring charges do not apply if services or features are ordered with initial ISDN-PRI installation, except as set forth in Note 4 below. If services or features are added to an existing PRI System, the Subsequent Service Order charge in B.1.d.(1) above will apply per order.

<sup>4</sup> ISDN-PRI Centrex Access or ISDN-PRI VOIP Centrex Access nonrecurring charges as set forth in Section 3 of this Product Guide always apply. Tie Channels are in addition to the normal channel charges.

<sup>5</sup> See III. Special Conditions, E.2.

<sup>6</sup> Rate is in addition to the applicable rates for 800 Service/OutWATS Service also apply. Charges assessed by Intermediary Customer Services providers will also apply.

<sup>7</sup> Call-by-Call Trunk supports Circuit Switched Data and DID/DOD Service.

Effective: April 1, 2023

INTEGRATED SERVICES DIGITAL NETWORK (SDN) - PRIMARY RATE INTERFACE (PRI) /  
BASIC RATE INTERFACE (BRI)

II. RATES AND CHARGES (Continued)

B. ISDN-PRIMARY RATE INTERFACE SERVICE (Continued)

	<u>Nonrecurring Charge</u>	<u>Monthly Rate</u>
1. <u>Month-to-Month Option</u> (Continued)		
f. Alternative Central Office		
<p>If ISDN-PRI Service is provided from an alternative central office, the following additional charges are applicable:</p>		
(1) Switched Facility (Local Central Office to ISDN-PRI Capable Central Office)		
(a) Option 1		
PRI DS1 Switched Facility	\$525.00	\$446.35
Special Transport Termination		30.00
Special Transport, per airline mile		11.00
(b) Option 2		
Alternate High Capacity Digital Facilities	2	2
Metro Ethernet Special Transport	--	1
2. <u>Term Option</u>		
a. PRI Access Switched Facility System		
(1) Option 1		
High Capacity Digital Facility (Customer's Premises to Local Central Office)		
1 Year Term	3	\$650.00 <sup>4,5</sup>
3 Year Term	3	600.00 <sup>6</sup>
5 Year Term	3	565.00 <sup>4,5</sup>

<sup>1</sup> In Metro Ethernet designated serving areas, the Metro Ethernet Special Transport rate may be used in lieu of the rate for Special Transport.

<sup>2</sup> DS1, DS3 or any other compatible High Capacity Digital Facility that meets specifications determined by the Utility and offered on a month-to-month basis may be utilized in lieu of the Switched Facility specified in Option 1. See the applicable Frontier Operating Companies Tariff FCC No. 14 or Frontier Operating Companies Tariff FCC No. 13, for applicable rates and terms.

<sup>3</sup> See Database Configuration, II.Rates and Charges B.2.c preceding.

<sup>4</sup> PRI Access Interface, High Capacity Digital Facility, standard features, first telephone number per channel activated, and B Channel Configurations (except for Tie Channel Services) are included in the term rate for PRI Access Switched Facility System, Option 1.

<sup>5</sup> The FCC End User Common Line monthly rate and FCC ISDN Line Port monthly rates are applicable as specified in Frontier Operating Companies Tariff FCC No. 14 and Frontier Operating Companies Tariff FCC No. 13 for Option 1.

<sup>6</sup> The 3-Year Term for PRI Access Switched Facility System is grandfathered and no longer available to new customers as of December 31, 2006. Existing customers on a 3-Year Term may continue their service until their term expires or their service is disconnected, whichever occurs first. Moves, additions or changes will not be permitted.

Effective: April 1, 2023

INTEGRATED SERVICES DIGITAL NETWORK (SDN) - PRIMARY RATE INTERFACE (PRI) /  
BASIC RATE INTERFACE (BRI)

II. RATES AND CHARGES (Continued)

B. ISDN-PRIMARY RATE INTERFACE SERVICE (Continued)

	<u>Nonrecurring Charge</u>	<u>Monthly Rate</u>	
2. <u>Term Option</u>			
b. B Channel Configurations			
(1) Circuit Switched Data	--	1	
(2) DID/DOD Service, First telephone number for each channel activated	--	1	
Additional telephone numbers	--	\$.66	(l)
(3) Tie Channel Service to customer premises or Central Office to Central Office, each per ISDN-PRI (11+ "B" Channels)	2,3		
1 Year Term		100.00	
2 or 3 Year Term		7	
5 Year Term		100.00	
(4) Tie Channel to an Intermediary Customer <sup>6</sup> per ISDN-PRI (7+ "B" Channels)	2,3		
1 Year Term		100.00	
2 or 3 Year Term		7	
5 Year Term		100.00	
(5) 800 Service	--	1,5	
(6) OutWATS Service	--	1,5	
(7) Call-by-Call Trunk	--	1,5,6	

<sup>1</sup> PRI Access Interface, High Capacity Digital Facility, standard features, first telephone number per channel activated, and B Channel Configurations (except for Tie Channel Services) are included in the term rate for PRI Access Switched Facility System, Option 1.

<sup>2</sup> Nonrecurring charges do not apply if Tie Channel Services are ordered with initial ISDN-PRI installation, except as set forth in Note 3 below. If Tie Channel Services are added to an existing PRI System, the Subsequent Service Order charge in II. Rates and Charges B.2.c.(2) following, will apply per PRI Access Switched Facility System.

<sup>3</sup> ISDN-PRI Centrex Access or ISDN-PRI VOIP Centrex Access nonrecurring charges as set forth in 11 of this Product Guide always apply. Tie Channels are in addition to the normal channel charges.

<sup>4</sup> See III. Special Conditions E.2.

<sup>5</sup> Rate is in addition to the applicable rates for 800 Service/OutWATS Service as specified in Section 26 of this Product Guide. Charges assessed by Intermediary Customer Services providers will also apply.

<sup>6</sup> Call-by-Call Trunk supports Circuit Switched Data and DID/DOD Service.

<sup>7</sup> 2- or 3-Year Terms are available with the Term & Volume Option in II.Rates and Charges B.3.e., following.

Effective: April 1, 2023

INTEGRATED SERVICES DIGITAL NETWORK (SDN) - PRIMARY RATE INTERFACE (PRI) /  
BASIC RATE INTERFACE (BRI)

II. RATES AND CHARGES (Continued)

B. ISDN-PRIMARY RATE INTERFACE SERVICE (Continued)

	<u>Nonrecurring Charge</u>	<u>Monthly Rate</u>	
2. <u>Term Option</u> (Continued)			
c. Database Configuration			
(1) Initial Service Order, PRI Access Switched Facility System, each	\$500.00	--	
(2) Subsequent Service Order, PRI Access Switched Facility System, each	200.00	--	
d. Optional Features			
(1) Calling Line Identification (CLID) with Name per PRI Access			(l)
1 Year Term	1	\$123.99	
5 Year Term	1	65.00	
(2) Two B Channel Transfer			
1 Year Term	1	70.00	
(3) PRI Station Detail Billing	1	100.00	
e. Alternative Central Office			
If ISDN-PRI Service is provided from an alternative central office, the following additional charges are applicable:			
(1) Switched Facility System	4	4	
(a) Option 1			
Special Transport Termination		30.00	
Special Transport, per airline mile		11.00	
(b) Option 2			
Alternate High Capacity Digital Facilities	3	3	
Metro Ethernet Special Transport	--	2	

<sup>1</sup> Nonrecurring charges for Database Configuration do not apply if optional features are ordered with initial ISDN-PRI installation. If optional features are added to an existing PRI System, the Subsequent Service Order charge in II. Rates and Charges B.2.c.(2) above will apply per PRI Access Switched Facility System.

<sup>2</sup> See the Facilities for Intrastate Access Tariff C-1, Section III, Special Access, for High Capacity Digital Facilities rates. In Metro Ethernet designated serving areas, the Metro Ethernet Special Transport rate may be used in lieu of the rate for Special Transport.

<sup>3</sup> DS1, DS3 or any other compatible High Capacity Digital Facility that meets specifications determined by the Utility and offered on a month-to-month basis may be utilized in lieu of the Switched Facility specified in Option 1. See the applicable Frontier Operating Companies Tariff FCC No. 14 or Frontier Operating Companies Tariff FCC No. 13, for the applicable rates and terms.

<sup>4</sup> See II. Rates and Charges A.11. for applicable rates.



Effective: January 15, 2024

INTEGRATED SERVICES DIGITAL NETWORK (SDN) - PRIMARY RATE INTERFACE (PRI) /  
BASIC RATE INTERFACE (BRI)

II. RATES AND CHARGES (Continued)

B. ISDN-PRIMARY RATE INTERFACE SERVICE (Continued)

3. <u>Term &amp; Volume Option</u>	<u>Monthly Rate</u> <sup>1</sup>	
<u>1 Year Commitment</u>		
a. ISDN-PRI Access System – Unlimited Voice Local Calling with DS1 Switched Facility Ports – 23B+D, 24B, 23B+D Backup, each <sup>2,3</sup>		
Package 1 - 1 + PRIs	\$2,025.09	(I)
b. ISDN-PRI Access System – Unlimited Voice Local Calling w/o DS1 Switched Facility Ports – 23B+D, 24B, 23B+D Backup, each <sup>2,3,4</sup>		
Package 1 - 1 + PRIs	833.75	
c. ISDN-PRI Access System – Measured with DS1 Switched Facility Ports – 23B+D, 24B, 23B+D Backup, each <sup>2</sup>		
Package 1 - 1 + PRIs	690.00	
d. ISDN-PRI Access System – Measured w/o DS1 Switched Facility Ports – 23B+D, 24B, 23B+D Backup, each <sup>2,4</sup>		
Package 1 - 1 + PRIs	450.00	

<sup>1</sup> The Database Configuration Charge for Initial Service Order in II.Rates and Charges B.2.c.(1) preceding does not apply for the initial order on a 1-, 2- or 3-Year Term and Volume Option. Database Configuration charges for the Term and Volume Option apply to Subsequent Service Orders only, per order.

<sup>2</sup> See II.Rates and Charges B.3.i following for B Channel Configurations.

<sup>3</sup> Includes unlimited local voice usage for direct dialed calls to Zones 1 and 2 and ZUM Zone 3. Data channels are measured usage only.

<sup>4</sup> DS1, DS3 or any other compatible High Capacity Digital Facility that meets specifications determined by the Utility may be utilized in lieu of the Switched Facility. See the applicable Frontier Operating Companies Tariff FCC No. 14 or Frontier Operating Companies Tariff FCC No. 13, for the applicable rates and terms.

Effective: January 15, 2024

INTEGRATED SERVICES DIGITAL NETWORK (SDN) - PRIMARY RATE INTERFACE (PRI) /  
BASIC RATE INTERFACE (BRI)

II. RATES AND CHARGES (Continued)

B. ISDN-PRIMARY RATE INTERFACE SERVICE (Continued)

3. Term & Volume Option (Continued)

	<u>Monthly Rate</u> <sup>1</sup>	
	<u>2 Year</u> <u>Commitment</u>	<u>3 Year</u> <u>Commitment</u>
e. ISDN-PRI Access System – Measured with DS1 Switched Facility Ports – 23B+D, 24B, 23B+D Backup, each <sup>2</sup>		
Package 1 - 1 to 10 PRIs	\$644.00	\$700.00 (I)
Package 2 - 11 to 20 PRIs	520.00	475.00
Package 3 - 21 to 29 PRIs	480.00	517.50
Package 4 - 30+ PRIs	420.00	410.00
f. ISDN-PRI Access System – Measured w/o DS1 Switched Facility Ports – 23B+D, 24B, 23B+D Backup, each <sup>2,4</sup>		
Package 1 - 1 to 10 PRIs	\$430.00	\$370.00
Package 2 - 11 to 20 PRIs	390.00	345.00
Package 3 - 21 to 29 PRIs	350.00	320.00
Package 4 - 30+ PRIs	275.00	265.00
g. ISDN-PRI Access System – Unlimited Voice Local Calling with DS1 Switched Facility Ports – 23B+D, 24B, 23B+D Backup, each <sup>2,3</sup>		
Package 1 - 1 to 10 PRIs	\$850.00	\$825.00
Package 2 - 11 to 20 PRIs	835.00	815.00
Package 3 - 21 to 29 PRIs	830.00	810.00
Package 4 - 30+ PRIs	825.00	805.00
h. ISDN-PRI Access System – Unlimited Voice Local Calling w/o DS1 Switched Facility Ports – 23B+D, 24B, 23B+D Backup, each <sup>2,3,4</sup>		
Package 1 - 1 to 10 PRIs	\$720.00	\$695.00
Package 2 - 11 to 20 PRIs	705.00	685.00
Package 3 - 21 to 29 PRIs	700.00	680.00
Package 4 - 30+ PRIs	695.00	675.00

<sup>1</sup> The Database Configuration Charge for Initial Service Order in II.Rates and Charges B.2.c.(1) preceding does not apply for the initial order on a 2- or 3-Year Term and Volume Option. Database Configuration charges for the Term and Volume Option apply to Subsequent Service Orders only, per order.

<sup>2</sup> See II.Rates and Charges B.3.i following for B Channel Configurations.

<sup>3</sup> Includes unlimited local voice usage for direct dialed calls to Zones 1 and 2 and ZUM Zone 3. Data channels are measured usage only.

<sup>4</sup> DS1, DS3 or any other compatible High Capacity Digital Facility that meets specifications determined by the Utility may be utilized in lieu of the Switched Facility. See the applicable Frontier Operating Companies Tariff FCC No. 14 or Frontier Operating Companies Tariff FCC No. 13, for the applicable rates and terms.

Effective: September 6, 2022

INTEGRATED SERVICES DIGITAL NETWORK (SDN) - PRIMARY RATE INTERFACE (PRI) /  
BASIC RATE INTERFACE (BRI)

II. RATES AND CHARGES (Continued)

B. ISDN-PRIMARY RATE INTERFACE SERVICE (Continued)

	<u>Nonrecurring Charge</u>	<u>Monthly Rate</u>	
3. <u>Term &amp; Volume Option</u> (Continued)			
i. B Channel Configurations			
(1) Circuit Switched Data	--	1	
(2) DID/DOD Service, First telephone number for each channel activated	--	1	
Additional telephone numbers	--	\$.53	(1)
(3) Tie Channel Service to customer premises or Central Office to Central Office, each per ISDN-PRI (11+ "B" Channels)	2,3		
		7	
All plans	\$100.00		
		7	
(4) Tie Channel to an Intermediary Customer <sup>4</sup> per ISDN-PRI (7+ "B" Channels)	2,3		
		7	
All plans	100.00		
		7	
(5) 800 Service	--	1,5	
(6) OutWATS Service	--	1,5	
(7) Call-by-Call Trunk	--	1,5,6	
j. Optional Features			
(1) Calling Line Identification (CLID) with Name per PRI Access 2 or 3 Year Term	8	\$40.00	
(2) Two B Channel Transfer 2 or 3 Year Term	8	65.00	
(3) PRI Station Detail Billing	8	100.00	
(4) Special Transport			
a) Termination		30.00	
b) Per airline mile		11.00	

<sup>1</sup> PRI Access Interface with or without DS1Switched Facility, standard features, first telephone number per channel activated, and B Channel Configurations (except for Tie Channel Services) are included in the term rate for PRI Access System, II. Rates and Charges B.3.e. or f preceding.

<sup>2</sup> Nonrecurring charges do not apply if Tie Channel Services are ordered with initial ISDN-PRI installation, except as set forth in Note 3 below. If Tie Channel Services are added to an existing PRI System, the Subsequent Service Order charge in II. Rates and Charges B.2.c.(2) preceding will apply per order.

<sup>3</sup> ISDN-PRI Centrex Access or ISDN-PRI VOIP Centrex Access nonrecurring charges always apply. Tie Channels are in addition to the normal channel charges.

<sup>4</sup> See III. Special Conditions. E.2

<sup>5</sup> Rate is in addition to the applicable rates for 800 Service/OutWATS Service. Charges assessed by Intermediary Customer Services providers will also apply.

<sup>6</sup> Call-by-Call Trunk supports Circuit Switched Data and DID/DOD Service.

<sup>7</sup> 1- and 5-Year Terms are available with the Term Option in II. Rates and Charges B.2.b. preceding.

<sup>8</sup> Nonrecurring charges do not apply if Optional Features are ordered with initial ISDN-PRI installation. If Optional Features are added to an existing PRI System, the Subsequent Service Order charge in II. Rates and Charges B.2.c.(2) preceding will apply per PRI Access Switched Facility System.

Effective: March 28, 2022

INTEGRATED SERVICES DIGITAL NETWORK (SDN) - PRIMARY RATE INTERFACE (PRI) /  
BASIC RATE INTERFACE (BRI)

II. RATES AND CHARGES (Continued)

C. DIGITAL (ISDN) SINGLE LINE SERVICES\*

	<u>Nonrecurring Charges</u>	<u>Monthly Rates</u>
1. Digital (ISDN) Single Line		
Each Business Single Line	1.2	1
2. ISDN Access	-	\$8.00
3. ISDN Multipoint Access	-	10.00
4. Central Office Services		
B Voice	-	2.25
B Circuit Switched Data (B-CSD) <sup>3</sup>	-	7.00
B Voice/CSD <sup>3</sup>	-	8.00
5. Additional Telephone Numbers	-	.40
6. Package Services		
ISDN Basic Station Service	\$30.00	7.00
ISDN Deluxe Station Service	30.00	8.25
Data 1000 <sup>3</sup>	15.00	3.00
Data 2000 <sup>3</sup>	15.00	5.00
7. Individual Services, per channel		
Data Direct Connect.	-	1.00
Data Closed User Group.	-	1.00
6-Way Conference	-	9.50
8. Data Base Change, per hour or portion thereof	60.00	-
9. Individual Line Loop Extension <sup>5</sup>		
a. Digital Single Line	50.00	21.50

(C)

<sup>1</sup> Residence Single Line Service is grandfathered and limited to existing customers at existing locations as of February 10, 2005. Moves, additions, or changes will not be permitted.

<sup>1</sup> See Section 4 of this Product Guide for rates applicable to Basic Exchange Access Line Services and Measured Rate Service - Local Calling.

<sup>2</sup> Nonrecurring Charges from Section 3 of this Product Guide (Initial Order, Central Office Activity, Outside Facility Connection, and Subsequent Order charges) are applicable.

<sup>3</sup> All data calls are measured and usage charges are applicable. See Section 4 of this Product Guide, Measured Rate Service - Local Calling Rates.

<sup>4</sup> As of February 13, 2004, this service is available for orders placed for CALEA. See III. Special Conditions D.16. following.

<sup>5</sup> These rates apply in addition to the rates for Digital (ISDN) Single Line Service.

\* Digital (ISDN) Single Line is grandfathered and limited to existing customers at existing locations as of March 28, 2022. Moves, additions or changes will not be permitted.

(N)  
(N)

Effective: April 1, 2016

---

INTEGRATED SERVICES DIGITAL NETWORK (SDN) - PRIMARY RATE INTERFACE (PRI) /  
BASIC RATE INTERFACE (BRI)

III. SPECIAL CONDITIONS

A. DEFINITIONS

Automatic Call Distribution-Management Information System (ACD/MIS). A central office based service which allows customers' incoming calls to be equally distributed to their available agents. Distribution of calls is determined by call parameters defined by the customer. The MIS data link passes call event information to the MIS located in the central office. Features are described in III.Special Conditions B.

Basic Rate Interface (BRI) Line. A two-wire facility which extends from a central office to a point of demarcation at a customer location. A BRI Line supports two 64 kilobytes per second (Kbps) B Channels and one 16 Kbps D Channel (2B+D).

B Channel (Bearer Channel). A PRI channel used to carry digitized voice and data information at a speed of 64 Kbps.

Call-by-Call Access. Network capability whereby one individual B Channel can be used for any of the services the customer desires. The individual B Channel, when programmed for Call-by-Call Access, can be used, at any one time, for DID, DOD, WATS, or CSD. The channel is not dedicated to a specific service.

Channel. The electrical path provided by the Company between two or more terminating points for the transmission of information or intelligence.

Clear Channel Capacity. The capability to transport 64 Kbps over a channel with no constraint on the quantity or on the sequence of bits.

D Channel (Delta Channel). A 64 Kbps PRI channel which carries information used to control PRI Line channels. A 16 Kbps BRI channel primarily used for signaling messages. The bit rate is fixed as a function of the interface used.

Digital (ISDN) Single Line. A Basic Rate Interface (BRI) Line for residence and business customers who require single line service. See definition for Basic Rate Interface.

Integrated Services Digital Network (ISDN). A set of standards which enable end-to-end digital transmission, access integration, and established standardization of points of interconnection over a single access line. End-to-end digital transmission eliminates the necessity for voice-band modems that use analog processing techniques. Access integration refers to utilizing a single ISDN line, whereby an end user over one line can access a wide variety of user information services such as voice, circuit switched data, and packet-switched data.

Caller ID. Provides for the display of the incoming call station number.

ISDN Access. The central office termination of a BRI line arranged for an individual user for access to the public switched network with one B-Voice Channel, one B-CSD or B-Packet Channel, and with one D Channel. Both B Channels do not need to be activated.

ISDN Multipoint Access. The central office termination of a BRI Line arranged for access to the public switched network with any one type of central office service such as B-Voice, B-CSD, or B-Packet, assigned to both B Channels and with one D Channel.

Effective: April 1, 2016

---

INTEGRATED SERVICES DIGITAL NETWORK (SDN) - PRIMARY RATE INTERFACE (PRI) /  
BASIC RATE INTERFACE (BRI)

III. SPECIAL CONDITIONS (Continued)

A. DEFINITIONS (Continued)

ISDN Station Service. A Basic or Deluxe package of central office functions operated or activated by customer premises equipment.

ISDN-PRI Service Arrangement. An ISDN-PRI Service Arrangement denotes one or more PRI Facilities plus PRI Access arranged together in the same or different central offices to provide one single service for the same customer.

Kbps. Kilobits per Second.

Mbps. Megabits per Second.

Network Ring Again. A service which notifies a caller when a station within a system becomes idles and completes a call to that station if activated.

Primary Rate Interface (PRI). The term "Primary Rate Interface" denotes the connection of a 1.544 Kbps digital facility to the ISDN-PRI capable Central Office switch. The twenty-four channels are typically divided into twenty-three B-Channels plus one D-Channel. Software in the ISDN-PRI equipped Central Office switch defines the type of access services that will be carried (e.g., DID- DOD, OutWATS, and 800 Service) within the 1.544 Mbps digital facility.

Primary Rate Interface (PRI) Access. The central office facility for terminating and channelizing a Primary Rate Interface.

Primary Rate Interface (PRI) Line. A four-wire facility which extends from a central office to a point of demarcation at a customer location. The PRI is a 1.544 Mbps carrier facility which is used to connect digital private branch exchanges or other channel controlling devices to the switched and private line networks. A PRI Line supports twenty-three 64 Kbps B-channels and one 64 Kbps D-channel.

Remote Switching Cluster - A Remote Switching Cluster exists when the remote switch is dependent on the host switch for its software processing. A remote switch can process intra-office calls without the host switch.

System. An interconnected arrangement of exchange and private-line services provided from one Central Office for use at one premises. The combination of Basic Rate Interface Lines plus ISDN Access and ISDN Multiline Access forming a complete communications system for a single customer of record. The intercom function is permitted only among stations within a system.

Tie Channel Service. Tie Channel Service provides intercom capability on B Channels of ISDN-PRI arrangements and other digital Centrex systems within the same subscriber network (central office-to-central office). This feature provides the capability to communicate on a private facility basis, as a tie line between Centrex systems served from different central offices. Tie channels on a single ISDN-PRI arrangement can be configured for intercom calling to a Centrex system and local exchange access for the Customer Premises Equipment (CPE). Intercom calls between an ISDN-PRI arrangement and a Centrex system do not incur usage charges. Calls to telephone numbers outside of a Centrex system without intercom capability may incur usage charges.

Effective: March 1, 2018

---

INTEGRATED SERVICES DIGITAL NETWORK (SDN) - PRIMARY RATE INTERFACE (PRI) /  
BASIC RATE INTERFACE (BRI)

III. SPECIAL CONDITIONS (Continued)

A. DEFINITIONS (Continued)

Tie Channel Service. (Continued) Tie Channel Service may terminate on CPE at the customer location or at an Intermediary Customer (IC) location. Rates for the Tie Channel Service to customer premises or central office-to-central office are available on a per B Channel basis, or on a per PRI basis when 11 or more B Channels are activated. Rates for Tie Channel Service to an IC are available on a per B Channel basis, or on a per PRI basis when 11 or more B Channels are activated. Tie Channel Service is available on a Month-to-Month basis or on a 1, 2, 3, or 5 Year Term. ISDN-PRI Centrex Access or ISDN-PRI VOIP Centrex Access nonrecurring charges as set forth in Section 11 of this Product Guide always apply. Tie Channels are in addition to the normal channel charges.

Tie Channel Service is available where facilities and conditions permit. Tie Channel Service will not be provided on a Call-by-Call basis.

Tie Channel Service to Intermediary Customers. B Channels may be dedicated or allowed to interconnect with various services provided by other service providers, such as Interexchange Carriers or competitive access providers. The customer shall be responsible for the ordering of these services.

User. A member of a business system.

B. DESCRIPTION OF SERVICES

CO Attendant Service

Aggregate Work Time/Number of Calls Handled for ISDN allows the display at an attendant position of amount of time spent handling calls, the amount of time the console was active, and the number of calls handled.

(D)  
(D)

Attendant Call Hold allows the attendant to hold a call in progress to originate another call or to pick up a call on hold. A timed reminder is activated when the call is placed on hold.

Attendant Call Splitting allows an attendant to talk privately with either the called or the calling party.

Attendant Call-Through Tests (Physical Trunks) allows an attendant to set up a test call over a specific trunk.

Attendant Camp-On allows calls made through an attendant to be held until the station becomes idle. A call waiting indication notifies the busy station.

Attendant Conference Calling allows conference calls among any combination of extensions or trunks.

Effective: April 1, 2016

---

INTEGRATED SERVICES DIGITAL NETWORK (SDN) - PRIMARY RATE INTERFACE (PRI) /  
BASIC RATE INTERFACE (BRI)

III. SPECIAL CONDITIONS (Continued)

B. DESCRIPTION OF SERVICES (Continued)

CO Attendant Service (Continued)

Attendant Console Terminal Management provides management services for the attendant console.

Button Management stores information about the use of console buttons.

Call Appearance Selection selects a call appearance on the console for incoming calls and attendant-originated calls.

Telephone Number Management permits assigning up to eight telephone numbers to an attendant group.

Display Management allows use of a console display

Lamp Management activates console lamps as programmed.

Tones Management activates a tone generator in the console if an emergency call is waiting, if a held call or an unanswered transferred call has expired, if calls are in queue, and if a call is alerting the console.

Attendant Control of Voice Terminals routes calls to an attendant automatically by a CO switch or manually by another attendant.

Attendant Direct Station Selection/Busy Lamp Field permits displaying as many as 10,000 telephone numbers in 100 groups of 100 contiguous numbers starting at 00.

Attendant Direct Trunk Group Selection allows the attendant to select an idle trunk for an outgoing call.

Attendant Emergency Override allows the attendant to complete incoming calls to stations that are busy, that have a series completion or multiline hunt arrangement, that are call forwarded, and that have terminating restrictions.

Attendant Incoming Calling Identification allows an attendant to identify the facility over which an incoming call was routed.



Effective: April 1, 2016

---

INTEGRATED SERVICES DIGITAL NETWORK (SDN) - PRIMARY RATE INTERFACE (PRI) /  
BASIC RATE INTERFACE (BRI)

III. SPECIAL CONDITIONS (Continued)

B. DESCRIPTION OF SERVICES (Continued)

CO Attendant Service (Continued)

Attendant Night Service forwards calls to a selected station.

Fixed Routing is controlled by the operating company and can be charged by a service order.

Flexible Routing uses Call Forwarding-Variable to arrange routing.

Trunk Answer From Any Station is activated by dialing an access code for call pickup.

Attendant Originated Permission Display (Class of Service Display) identifies the originating permissions of lines that have been routed to the attendant.

Attendant Position Busy activates a busy condition at an attendant position.

Attendant Power Failure Transfer (ISDN Communication Failure) routes calls to a preassigned telephone number during a power failure.

Attendant Selective Customer Control of Facilities allows an attendant to deny access to a trunk or simulated facility group.

Attendant Through Dialing allows an attendant to access an outgoing facility for a caller who has difficulty placing calls.

Attendant Timed Reminder times calls that are camped-on, that are not answered after a transfer, or that are on hold.

Attendant Traffic counts aggregate work time for the position, minutes the position has been active, and number of calls handled by the position.

Attendant Trunk Group Indicators allow an attendant to monitor the level of traffic on customer selected trunk groups.

Attendant Trunk Identification permits displaying the trunk group and number of the trunks in use.

Attendant Trunk Queuing permits queuing of calls when all trunks in a trunk group are busy and provides call-back when a trunk becomes available.

Automatic Dropback to ISDN Attendant (Serial Calls) lets an attendant complete a call from an incoming trunk to two or more stations in succession, without requiring the calling party to redial the attendant.

Effective: April 1, 2016

---

INTEGRATED SERVICES DIGITAL NETWORK (SDN) - PRIMARY RATE INTERFACE (PRI) /  
BASIC RATE INTERFACE (BRI)

III. SPECIAL CONDITIONS (Continued)

B. DESCRIPTION OF SERVICES (Continued)

Attendant Timed Reminder (Continued)

Dial Access to ISDN Attendant provides dial access from stations within a customer group.

Even Call Distribution (Uniform Call Distribution) distributes calls evenly among multiple attendant positions.

Attendant Call Forwarding allows an attendant to activate or deactivate call forwarding for any station.

Number of Calls on Queue-ISDN Attendant permits displaying calls on queue.

Queuing of ISDN Attendant with Call Waiting Indication (Lamps) permits queuing calls of a particular type.

Total Number of Calls Handled Display Data for ISDN Attendants provides information about calls processed at an attendant position in the ISDN attendant group. The information includes average length of calls held in queue that are abandoned before being served, average length of calls held in queue that are served, longest time for a call held in queue, number of calls held in queue but abandoned before being served, and number of calls served.

Basic Service Functions Direct Inward Dialing (DID), Direct Outward Dialing (DOD), Distinctive Ringing, Station-to-Station Calling (Intercom), Touch Call, and Incoming Calling Number Identification (Station-to-Station).

Centrex Feature Packages

The following features are available in Feature Packages 1000, 2000, and 3000. Features may not be substituted to, deleted from, or transferred between packages. Feature definitions:

Call Forward - allows incoming calls to a Centrex station to be automatically forwarded to another telephone number. There are three variations of Call Forward: (1) forward all calls, (2) forward when busy, or (3) forward when no answer. Forwarding for hunt groups is available for the above three options.

Call Hold - enables a station, engaged in a call, to set the call into a holding condition completely freeing the station to place a call, receive a call, and or use other Centrex services. One call per station line can be held at a time.

Call Pickup - allows one party to dial a code and pickup another party's ringing telephone thus connecting the calling party with the party that dialed the code. The pickup can be directed to any person within a call pickup group or to a specific station number.

Call Transfer - allows a station to hold and transfer calls. During the transfer the transferring and receiving stations talk privately. Call Transfer allows station users to transfer a direct inward call to a telephone number inside or outside the customer group. The station user who hangs up may then originate and receive calls. This feature may be selectively denied from certain stations.

Effective: April 1, 2016

---

INTEGRATED SERVICES DIGITAL NETWORK (SDN) - PRIMARY RATE INTERFACE (PRI) /  
BASIC RATE INTERFACE (BRI)

III. SPECIAL CONDITIONS (Continued)

B. DESCRIPTION OF SERVICES (Continued)

Centrex Feature Packages (Continued)

Charges between the originating location and the DID-DOD transfer equipped station will be billed to the originating caller. The transferring Centrex station will be responsible for applicable charges from the Centrex station to the telephone number that answers the transferred call. All local, measured unit, zone units, and toll charges are applicable in accordance with this Product Guide.

Call Waiting - an incoming call encountering a busy station receives audible ringing. The called busy station receives a call waiting tone and may then acknowledge the incoming caller, place the existing caller on hold, then alternate between callers or abandon one of the calls. Call Waiting has three configurations depending on the station user's needs: (1) CW -Incoming only, (2) CW - Originating, or (3) CW - Terminating.

Conferencing (Three Way Calling) - allows a station to conduct the following configurations: (1) two other system stations, (2) one system station and one outside party, or (3) two outside parties.

Distinctive Ringing - provides for distinctive different rings at the called station to distinguish between a direct inward dialed (DID) call and an intra-group call.

Speed Calling (6-8) - allows each station user to place calls to its own previously designated electronic list of either 6 or 8 (depending on switch type) frequently dialed numbers.

Station Hunting - when the called station is busy, allows for the routing of the incoming call to an idle station in a prearranged hunt group.

Station-to-Station Dialing - allows a station user to dial another station within the same Centrex customer group using just the last four digits of the telephone number. Station-to-station dialing is not available within the feature package, but is available with the ISDN line.

The following features, in addition to the ones defined above, are available from Feature Packages 2000 and 3000:

Automatic Call Back (Camp On) - allows a station reaching a busy condition on an internal call to be notified when that busy station becomes available and to be placed automatically in a "call back" mode. After invoking the Camp On feature, the station may make and receive calls, or make general use of the system. At the moment both stations are free, Centrex will call the originating station first and when the user answers, the system will call the camped-on station.

Call Park - allows a station engaged in a call to place the call into a holding condition for access from another station in the system. (Call Park differs from Call Hold in that the call placed on hold is associated with an index code, or in some systems a station number, and does not standby for access by the station which placed the call on hold. Call Park allows any station to dial a Call Park retrieval code to be connected to the held call.) Call Park is offered from digital switches only.

Last Number Redial - allows the user to redial his/her last manually dialed number by depressing a single key.

Effective: April 1, 2016

---

INTEGRATED SERVICES DIGITAL NETWORK (SDN) - PRIMARY RATE INTERFACE (PRI) /  
BASIC RATE INTERFACE (BRI)

III. SPECIAL CONDITIONS (Continued)

B. DESCRIPTION OF SERVICES (Continued)

Centrex Feature Packages (Continued)

The following features, in addition to the ones defined above, are available from Feature Packages 2000 and 3000:  
(Continued)

Toll Restriction - disallows the dialing of long distance calls. The Company may provide predetermined toll restriction packages (i.e., restriction to local area code, restriction to Local LATA, etc.) which will restrict dialing to specific areas.

The following features, in addition to the ones defined above, are available from Feature Package 3000:

Automatic Route Selection/Flexible Route Selection (ARS/FRS) - automatically selects the most economical route to a destination. The customer controls and programs a predetermined routing pattern for WATS, Foreign Exchange, DDD trunks, etc.

Feature Package 3000 includes 3-digit routing to selectively route calls over two or more routes with a capacity of 8 patterns per customer group.

Remote Access to Features - allows a user who is away from the office to dial directly into the Centrex system (without attendant intervention) and gain complete access to Centrex system facilities and outgoing trunk circuits. The caller is required to have a "security access" code.

Message Detail Recording - provides a record to the customer of originating messages routed over tie lines and private lines under certain conditions, FX, WATS, CCSA, and/or exchange and toll network. It is not a source for billing detail.

- (1) It includes the calling station number, called number, date, time of day, duration of call and type of facility routing.
- (2) Call attempts over some FX facilities, whether completed or not, will be recorded. Message detail will not be provided for intra-Centrex customer group.
- (3) Message detail for a call routed over a WATS trunk will include the called number, date, time of day, duration of call, type of facility routing and may include the calling station number.

Effective: April 1, 2016

---

INTEGRATED SERVICES DIGITAL NETWORK (SDN) - PRIMARY RATE INTERFACE (PRI) /  
BASIC RATE INTERFACE (BRI)

III. SPECIAL CONDITIONS (Continued)

B. DESCRIPTION OF SERVICES (Continued)

Circuit Switched Data (CSD) Channel Service Functions

Data 1000 Package

Data Call Forward allows incoming calls to be automatically forwarded to a predetermined telephone number.

Data Multi-Line Hunt Group allows sequential hunting for an idle line.

Data Speed Call-Short List permits speed calling from an individual Circuit Switched Data Channel. A short list consists of a maximum of eight stored numbers.

Data Toll Restriction denies placement of calls attempted from a CSD channel.

Data 2000 Package

Data Call Back allows a caller to be notified when a called line becomes idle. The call is then automatically established.

Data Circular Hunting permits hunting starting with the first idle line found by the previous hunt and continuing until the hunting starting point is reached.

Data Group Speed Calling 30 permits speed calling on a group of CSD channels for up to thirty stored numbers.

Data Speed Call-Long List provides speed calling on an individual CSD channel for up to thirty stored numbers.

Individual Services

Data Closed User Group permits arranging a Circuit Switched Data Channel so that calls within the group are allowed but calls between groups are denied.

Data Direct Connect - This feature provides an automatic off-hook connection to a predetermined location.

ISDN Basic Station Service

Analog Shared Telephone Number on all SM Configurations allows analog lines that share telephone numbers with ISDN keysets to be assigned to switching modules that do not contain ISDN software.

Automatic Call-Back on Busy automatically calls a station when it becomes idle.

Bridging allows a party to establish a conference call within a customer group by bridging into a call. Only one party can bridge into a call. Bridging can be inhibited by activating Manual Exclusion.

Call Forwarding allows a user to forward calls to a specified number.

Call Pickup allows a user to pick up a call directed to another station in the customer group.

Effective: April 1, 2016

---

INTEGRATED SERVICES DIGITAL NETWORK (SDN) - PRIMARY RATE INTERFACE (PRI) /  
BASIC RATE INTERFACE (BRI)

III. SPECIAL CONDITIONS (Continued)

B. DESCRIPTION OF SERVICES (Continued)

ISDN Basic Station Service (Continued)

Conference Calling allows a user to set up a conference call. Conference calls can include members of the customer group and parties outside the group. Up to six parties can be connected.

Drop. Allows a user to disconnect the last party added to a conference call.

Hold. Allows a user to place a call on hold, or answer a call.

Intercom Function allows a station set to emulate a dedicated connection to another station for priority conversations while permitting incoming calls or connection of active calls.

Key System Coverage for Analog Lines allows an analog station set to share calls with an ISDN station set.

Manual Exclusion allows a user to inhibit other stations from picking up calls on hold or from bridging onto calls. (See Privacy Release.)

Multi-Line Hunting allows an incoming call to "roll over" to an unused station when the number being called is busy or not being answered.

Multiple Directory Number provides access to more than one directory number.

Privacy Release allows a user to inhibit other stations from answering a call on hold or from bridging onto calls. (See Manual Exclusion.)

Ring Again allows a user to arrange for Automatic Callback on Busy when a busy number is encountered. When the busy station becomes idle, a distinctive ring alerts the caller. When the station set is taken off-hook, the call is placed.

Shared Call Appearances of a Directory Number allows several stations to share one or more directory numbers. Calls originating or terminating at one station will affect all stations sharing a directory number.

Speed Calling - Individual Short List permits the customer to dial selected telephone numbers using fewer digits than normally required. Access to a Speed Calling list is limited to an individual user, and a list can not be shared by other users.

Transfer allows a user to transfer a call to another directory number in the customer group.

Time and Date Display is a subscription feature for ISDN attendants and ISDN station set users.

Transfer allows transferring a call to another telephone number in the customer group.

Two-Digit Intercom Dialing allows abbreviated dialing of stations for up to 100 numbers.

Effective: April 1, 2016

---

INTEGRATED SERVICES DIGITAL NETWORK (SDN) - PRIMARY RATE INTERFACE (PRI) /  
BASIC RATE INTERFACE (BRI)

III. SPECIAL CONDITIONS (Continued)

B. DESCRIPTION OF SERVICES (Continued)

ISDN Deluxe Station Service

Delayed and Abbreviated Ringing alerts a station for a predetermined interval before ringing a designate station.

Display for Ringing Call Appearances Only will activate displays on a keyset for ringing call appearances.

Initiated Priority Calling provides an ISDN equivalent of Dial Call Waiting. A station user initiates a priority call by one of two methods: dialing the initiated priority calling function code or pressing a priority calling feature button, then dialing the digits of the called party.

Inspect for ISDN Terminals displays information about an active call, a call on hold, or an alerting call. The information includes call appearance identification, called or calling telephone number, incoming call identifier call type, called or calling party name, and originating permissions.

Intercom Alerting provides a distinctive ring indicator or visual indicator of an intercom call.

Originating Priority Calling designates all calls originated from a particular station as priority calls.

Outgoing Called Line Identification for ISDN Terminals provides a caller with facility and call destination information.

Priority Calling Incoming Only allows calls from outside the business group to terminate on a priority call appearance.

Effective: April 1, 2016

---

INTEGRATED SERVICES DIGITAL NETWORK (SDN) - PRIMARY RATE INTERFACE (PRI) /  
BASIC RATE INTERFACE (BRI)

III. SPECIAL CONDITIONS (Continued)

B. DESCRIPTION OF SERVICES (Continued)

Packet Switching Service Features<sup>1</sup>

X.25 Basic

X.25 Flow Control Parameter Negotiation permits negotiation on a per call basis of the flow control parameters.

X.25 Incoming Calls Barred prohibits a data terminal from terminating an incoming call. This function is activated by a service order.

X.25 Outgoing Calls Barred prohibits a data terminal from originating outgoing virtual calls. This function is activated by service order.

X.25 Reverse Charge allows a user, on a pre-call basis, to assign billing charges to the called party rather than the calling party.

X.25 Reverse Charge Acceptance permits the data communications equipment to transmit incoming calls requesting reverse charging to the user.

X.25 Throughput Class Negotiation allows the calling data terminal to request specific throughput classes in the call request package for both directions of data transmission. This function is activated by service order.

X.25 Transmit Delay Selection and Indication allows the data terminal to specify an acceptance transit delay on a per-call basis for virtual calls.

<sup>1</sup> Service is grandfathered and limited to existing customers as of February 13, 2004.



Effective: April 1, 2016

---

INTEGRATED SERVICES DIGITAL NETWORK (SDN) - PRIMARY RATE INTERFACE (PRI) /  
BASIC RATE INTERFACE (BRI)

III. SPECIAL CONDITIONS (Continued)

B. DESCRIPTION OF SERVICES (Continued)

Packet Switching Service Features<sup>1</sup> (Continued)

X.25 Deluxe

X.25 Closed User Groups allows ISDN subscribers to establish subnetworks within which the members of a closed user group can communicate. Communication with users who are external to the closed user group is not permitted. The closed user groups are established by a service order. A user can belong to multiple closed user groups.

X.25 Fast Select allows a sending data terminal to forward up to 128 bytes of data along with call setup and clearing packets.

X.25 Fast Select Acceptance allows the switch to transmit incoming call packets with the fast select facility to a destination terminal that has this feature.

X.25 Hunt Groups allow a grouping of access lines so that an incoming packet-switched data call to the hunt group is completed if there is an available logical channel on any of the access lines within the hunt group. A Hunt Group is established by service order. Members of a Hunt Group can be distributed among the ISDN switching modules within the switch, but the Hunt Group cannot span switches. A basic rate interface within a Hunt Group can have its own address (individual line addressing) and can accept calls independent of the Hunt Group. A Hunt Group can have multiple group addresses.

X.25 One-Way Outgoing Logical Channel allows an ISDN subscriber to specify some number of the logical channels to be used only for calls that they originate. This feature is activated by service order.

X.25 Permanent Virtual Circuit allows packet switching to be implemented over a dedicated logical channel without needing call setup or clearing. The permanent virtual circuit is established by a service order.

Automatic Call Distribution-Management Information System (ACD/MIS)

Automatic Call Distribution (ACD) is a central office based service which allows customers' incoming calls to be equally distributed to their available agents. Distribution of the calls is determined by call parameters defined by the customer. ACD also allows the customer to manage fluctuations in call patterns, trunk loading, answering time patterns, and answering time frames.

Automatic Call Distribution can be enhanced with the extensive call handling and management capability of the Automatic Call Distribution-Management Information System (ACD/MIS). The Management Information System Data Link contains real-time call information that is forwarded from a Management Information System (MIS) located in the Company's central office. In turn, the MIS provides the customer with a global view of ACD call activities within the customer's call center. The information assists in evaluating traffic patterns, trunk utilization, agent efficiency and lost calls. At the supervisor level, ACD/MIS provides the ability to monitor agents, control the origination and destination of incoming calls and rearrange groups in response to incoming customer call demand.

<sup>1</sup> Service is grandfathered and limited to existing customers as of February 13, 2004.

Effective: April 1, 2016

---

INTEGRATED SERVICES DIGITAL NETWORK (SDN) - PRIMARY RATE INTERFACE (PRI) /  
BASIC RATE INTERFACE (BRI)

III. SPECIAL CONDITIONS (Continued)

B. DESCRIPTION OF SERVICES (Continued)

Automatic Call Distribution - Management Information System (ACD/MIS) (Continued)

Features

Basic ACD Feature Package (Single or Multipoint)

- Access to Switched Network
- Activate/Deactivate Position
- Agent Alerting and Call Origination Identification
- Agent Event Codes
- Agent Monitoring with Interrupt
- Agent/Supervisor Assignment
- Automatic Call Distribution
- Call Hold Incoming/Outgoing
- Call Queuing-Call Transfer Internal/External
- Call Waiting Indicator
- Cancel Previous Entry
- Conference and Transfer on Outbound Calls
- Emergency Alert
- Enhanced Incoming Call Alerting
- Interposition Conference
- Intraflow
- Music on Hold
- Position Release with Disconnect
- Queue Slots (equal to the number of agents)
- Service Assistant Capabilities
- Standard Announcements

Advanced ACD/MIS Features

- Additional Queue Slots-Call Prompts
- Call Vectoring, which includes:
  - Answer Supervision Control
  - Music on Queue
- Direct Agent Access
- Management Information System (MIS) Data Link, which includes:
  - Delay Treatment
  - Fold Down
  - Interflow Control
  - Intraflow Control
  - Overload Control
  - Queue Control

Effective: April 1, 2016

---

INTEGRATED SERVICES DIGITAL NETWORK (SDN) - PRIMARY RATE INTERFACE (PRI) /  
BASIC RATE INTERFACE (BRI)

III. SPECIAL CONDITIONS (Continued)

B. DESCRIPTION OF SERVICES (Continued)

Automatic Call Distribution - Management Information System (ACD/MIS) (Continued)

Features (Continued)

Access to Switched Network - Outbound call dialing permission ranging from total restriction to unrestricted access to the network.

Activate/Deactivate Position - Allows agents to activate their positions for availability to accept calls (activate or log on) or to deactivate (log off or make busy) their positions to not accept any new incoming calls. Deactivation occurs whenever a headset is unplugged. With this feature, no incoming calls are delivered to unavailable or unattended positions.

Additional Queue Slots - When the required number of Queue Slots needs to exceed the number of customer agents.

Agent Alerting and Call Origination Identification - Upon delivery of an incoming call, this feature provides an audible tone and a 10-character display of the dialed digits and/or the incoming trunk group.

Agent Event Codes - Allows agents, while on a call, to enter an -event code. Event codes are set up to meet customer needs for tracking specific occurrences, such as types of billing questions, effectiveness of various types of advertising, customer demographics, etc. The frequency of the events are tabulated and reported on the Management Information System (MIS).

Agent Monitoring with Interrupt - Allows the supervisor position the ability to monitor agent positions and to interrupt the monitored conversation.

Agent/Supervisor Assignment - Allows the assignment of a log in identification and password to each agent and supervisor, independent of their terminals.

Automatic Call Distribution - Distributes calls automatically to agents available for the longest period of time.

Call Hold Incoming/Outgoing - Allows the agent to place an incoming call on hold and have full use of the position to consult with another agent or supervisor or make an outside call. Call Hold Outgoing allows the agent to place an outgoing call on hold. If an incoming call is also on hold, the agent can go back and forth between the two parties on hold or the agent can conference all involved parties.

Call Prompts - An enhancement to Call Vectoring that is an announcement to guide incoming callers through a series of steps to route the call to an agent. The incoming caller responds to the steps by depressing a touch call digit on his telephone set.

Call Queuing - When all customer agents are busy, this feature ensures incoming calls are distributed in the order of arrival (first come, first serve) by entering the calls into queues.

Effective: April 1, 2016

---

INTEGRATED SERVICES DIGITAL NETWORK (SDN) - PRIMARY RATE INTERFACE (PRI) /  
BASIC RATE INTERFACE (BRI)

III. SPECIAL CONDITIONS (Continued)

B. DESCRIPTION OF SERVICES (Continued)

Automatic Call Distribution - Management Information System (ACD/MIS) (Continued)

Features (Continued)

Call Transfer Internal/External - Call Transfer Internal allows an agent to transfer a call to another agent or supervisor within a call center. Call Transfer External allows an agent to transfer a call outside of the call center.

Call Vectoring - Provides the ability to program a series of call handling steps that a call will follow before the call is connected to an agent. The series of steps is referred to as a call vector. The feature includes:

- Answer Supervision Control - Provides the ability to control the point at which answer supervision is returned for calls that are processed using call vectors.
- Music On Queue - Provides additional flexibility for the specification of music and/or other audio treatment of calls in queue.

Call Waiting Indicator - Causes an indication to appear on all agent terminals when the waiting interval of a call in queue exceeds a specified threshold.

Cancel Previous Entry - Allows an agent to delete previously entered digits.

Conference and Transfer on Outbound Calls - Allows an agent to conference an outbound call with another party and to transfer an outbound call to another party.

Direct Agent Access - Provides the ability for an external call to reach an agent directly. The agent position must be assigned an individual directory number.

Emergency Alert - Provides a single keystroke method of flagging calls of special interest or that require handling.

Enhanced Incoming Call Alerting - Provides an enhanced audible alert of an incoming call even when the agent is not wearing a headset. A visual alert accompanies the audible alert.

Interposition Conference - Allows an agent to conference with another agent or supervisor.

Intraflow - Allows the customer flexibility to increase the number of agents to handle incoming calls. This feature allows the customer to designate one principle serving team and up to eight supporting teams for each call queue.

Effective: April 1, 2016

---

INTEGRATED SERVICES DIGITAL NETWORK (SDN) - PRIMARY RATE INTERFACE (PRI) /  
BASIC RATE INTERFACE (BRI)

III. SPECIAL CONDITIONS (Continued)

B. DESCRIPTION OF SERVICES (Continued)

Automatic Call Distribution - Management Information System (ACD/MIS) (Continued)

Features (Continued)

Management Information System Data Link - Passes call event information to the Management Information System (MIS) located in the central office. This Data Link includes:

- Delay Treatment - Provides various types of alerting to the calling parties when their call cannot be routed immediately to an agent, i.e., the call is put in a queue.
- Fold Down - Provides for an orderly restriction of traffic to a smaller number of agent positions during periods of low incoming traffic.
- Interflow Control - Provides the ability to reroute incoming calls to destinations outside the switch.
- Intraflow Control - Provides a way of increasing the number of agents able to handle calls by specialized serving teams for call queues.
- Overload Control - Promptly detects and properly controls an overload condition.
- Queue Control - Alerts the customer of queuing delays that have exceeded customer designated thresholds; through the MIS the customer can modify the ACD parameters in order to relieve the condition.

Music on Hold - Routes an incoming call placed on "hold" to be routed to an audio source which provides music.

Multipoint ACD - Allows two agents stations to be placed on one ACD line. Each station will use one B channel and share the D channel.

Position Release with Disconnect - Allows an agent to release the position from a call with one keystroke.

Queue Slots - Dedicated time slots used to hold incoming calls in a delayed state until an agent position becomes available. The number of queue slots must be equal to the number of agents.

Service Assistant Capabilities - Provides agents single keystroke access for assistance on difficult calls.

Standard Announcements - Provides audio announcement of answering delays to customers in queue. The announcement is provided by the Company and located in the central office.

Effective: April 1, 2016

---

INTEGRATED SERVICES DIGITAL NETWORK (SDN) - PRIMARY RATE INTERFACE (PRI) /  
BASIC RATE INTERFACE (BRI)

III. SPECIAL CONDITIONS (Continued)

C. GENERAL

1. ISDN Services will be furnished only where facilities are available. ISDN Services are offered on a limited basis by specific switching systems within certain geographical areas. Since ISDN Services are not offered in all areas, it is important to verify their availability by contacting your Company account representative or Business Office at the telephone number listed in your telephone directory under the heading "Where to Reach Frontier," for installations and service.
2. Services offered in accordance with this Product Guide are provided from central offices equipped with digital facilities. The availability of services and ability to provide services may vary among serving central offices.
3. Customer-provided equipment used in conjunction with services provided in accordance with this Product Guide must conform with the technical specifications of the Company.
4. The Company may change telecommunications services, equipment, operations, or procedures while remaining consistent with the Federal Communications Commission's Rules and Regulations. If changes cause a customer's equipment or communications system to become incompatible with services or if changes cause terminal equipment to require modification or become less effective, the Company shall not be responsible. Customers will be given notice, in writing, of forthcoming changes to network services that might affect terminal equipment or private communications systems.
5. End User Common Line charges as authorized by the FCC and Joint Board will apply.
6. Temporary disconnections (for vacations or other reasons) are not permitted.
7. Directory listings will be provided in accordance with the rates and conditions found elsewhere in the Company's Product Guide.
8. A change in services from Centrex, from Basic Exchange Access Line services, from Digital Channel Service, from a private line service, or from a combination of services to ISDN-PRI services is a discontinuation of services and an establishment of service. Charges applicable to installation and service connections and all other charges applicable to the establishment of ISDN-PRI service apply.
9. A change in service to ISDN will cause a temporary interruption of service.
10. A customer with 80% of its lines at the primary service address may have up to four (4) additional locations, with a minimum of two (2) lines at each location. All lines must be within the same serving area of the same central office and the additional locations are those of the customer, or the customer's legal owner and/or legal parent subsidiary or affiliate. Rates for customers with six (6) or more locations, will be provided on an individual case basis. Schools, hospitals and government entities are excluded.

Effective: March 28, 2022

---

INTEGRATED SERVICES DIGITAL NETWORK (SDN) – PRIMARY RATE INTERFACE (PRI) /  
BASIC RATE INTERFACE (BRI)

III. SPECIAL CONDITIONS (Continued)

D. ISDN-BASIC RATE INTERFACE (BRI) SERVICES\*

(C)

1. BRI Services are digital exchange services which include station connections and network access.
2. BRI Services offered from this Product Guide include from two (2) to five hundred (500) parings of a BRI Line with either an ISDN Access Service or an ISDN Multipoint Access Service and with one variation of Central Office Elements. The Central Office Elements can be arranged in a variation suitable to customer requirements but will include no more than two B-Channel Elements and one D-Channel Element.
3. BRI Services provided on a Foreign Exchange basis are provided on an ICB basis.
4. BRI Services provided in accordance with this Product Guide are available to customers requiring from two (2) to five hundred (500) BRI Lines. Customers requiring more than five hundred (500) lines will be provided service at rates and charges and with respect to conditions specified in individual agreements.
5. No more than one voice-type Service Package will be provided for each BRI Line, regardless of the number of voice-type B-Channels. Each Service Package is associated with a BRI Line, not with a channel.
6. Each BRI Line within a system may be uniquely arranged with one of several Service Packages and with any combination of B-Channels.
7. ISDN Access and ISDN Multipoint Access are services which terminate BRI Lines at the central office and permit access to the exchange network. One access (either ISDN Access or ISDN Multipoint Access) is required for each BRI Line.
8. An ISDN Access arranges a BRI Line for an individual user.
9. An ISDN Multipoint Access arranges a BRI Line for multiple users or arranges a BRI Line for more than one voice-type B Channel.
10. The B Circuit Switched Data Channel (B-CSD) assigns circuit switched data traffic to one of the two B Channels of a BRI Line. The CSD channel operates at a maximum speed of 64 kbps (Switched 64 kbps) but may be used at a speed of 56 kbps (Switched 56 kbps).
11. Both B Channels of a BRI Line may be arranged for B-CSD.
12. Data sent to locations within a system and to interexchange carriers over B-CSD Channels can be transmitted at either 64 kbps or 56 kbps. (Some interexchange carriers do not offer transmission at 64 kbps.)
13. Data sent to locations within other systems must be transported at a speed of 56 kbps, if permitted. If permitted, the rates, charges, and conditions will be specified by the Company's Product Guide.
14. The B Voice/CSD Channel arranges a BRI Line with the capability to alternate transmission between Voice and Circuit Switched Data over the same B Channel. Both B Channels may be arranged for B Voice/CSD.

\* Integrated Services Digital Network – Basic Rate Interface is grandfathered and limited to existing customers at existing locations as of March 28, 2022. Moves, additions or changes will not be permitted.

(N)  
(N)

Effective: March 28, 2022

---

INTEGRATED SERVICES DIGITAL NETWORK (SDN) – PRIMARY RATE INTERFACE (PRI) /  
BASIC RATE INTERFACE (BRI)

III. SPECIAL CONDITIONS (Continued)

D. ISDN-BASIC RATE INTERFACE (BRI) SERVICES\* (Continued)

(C)

15. The D Packet 1 Switched Data Channel allows transmission of packet-switched data over a D Channel. Subscription to a D Packet element without subscription to B Channel elements is permitted.
16. B Packet service provided to customers who require packet switched data service to access the DPN100 public switched network<sup>1</sup>. Orders for the Communication Assistance for Law Enforcement Act (CALEA) will continue to be provisioned from 5ESS switches as access to the public switched network is not required.
17. Attendant Services
  - a. Attendant Services require compatible customer-provided equipment. Functions performed with equipment at the customer's premises must conform with the Company's operating practices and procedures in order to maintain service levels.
  - b. The Attendant Services package requires a single B-Voice Channel configuration on the BRI line.
18. Service Orders
  - a. Temporary disconnections (for vacations or other reasons) and facility reservation of BRI services are not permitted.
  - b. Minimum Service Requirement - Subscribers will be billed a minimum equivalent to the rates for continuing service for three months and charges for establishing service.
  - c. Directory Listings will be furnished in accordance with the rates and conditions of this Product Guide.
  - d. A change in service from Centrex or Basic Exchange Access Line services to BRI services is a discontinuation of service and an establishment of service. Termination liabilities will not apply to changes if the customer subscribes to the same number or to more lines. However, all applicable installation and service connection charges and all charges applicable to the establishment of BRI service apply.
  - e. A change in services will cause a temporary interruption of service.
19. Additional Telephone Numbers
  - a. A primary telephone number is provided with each activated BRI channel. Additional telephone numbers may be ordered for each BRI line. Additional telephone numbers are available at the rate shown in this Section.
  - b. At least one additional telephone number is required for each Multipoint Access user.
  - c. One interexchange carrier must be selected for all telephone numbers associated with the same BRI Line, however, 10xxx access to other carriers is provided. All BRI Lines within the same business system need not be associated with the same carrier.

<sup>1</sup> Service is grandfathered and limited to existing customers as of February 13, 2004.

\* Integrated Services Digital Network – Basic Rate Interface is grandfathered and limited to existing customers at existing locations as of March 28, 2022. Moves, additions or changes will not be permitted.

(N)

(N)



Effective: March 28, 2022

---

INTEGRATED SERVICES DIGITAL NETWORK (SDN) – PRIMARY RATE INTERFACE (PRI) /  
BASIC RATE INTERFACE (BRI)

III. SPECIAL CONDITIONS (Continued)

D. ISDN-BASIC RATE INTERFACE (BRI) SERVICES\* (Continued)

(C)

20. ISDN Multipoint Access

- a. Multipoint Access allows connecting from one to eight users on an individual BRI line.
- b. Multipoint Access is required for connecting two B-Channel Elements for voice on the same BRI line.
- c. Only one user will be allowed to access each B-Channel. Other users on the same BRI line can access the D-Channel only.
- d. Up to eight users can share simultaneously the same D-Channel of a D-Channel packet switching arrangement.
- e. Multipoint Access to a BRI line connecting an attendant's console is not permitted.

21. Individual Line Loop Extension

ISDN Individual Line Loop Extension provides a physical extension of the BRI loop from approximately 18,000 feet to approximately 36,000 feet when provided from an ISDN capable Central Office. This physical extension is accomplished by means of a CO installed power module and an outside plant installed regenerator or U-Repeater.

The deployment method is based upon dB loss and not on specific cable footage. The vendor installation information indicates that up to a 34dB loss at 40kHz in either direction of the field repeater is acceptable. With the Frontier engineering practice of maximum loss for the ISDN BRI loop to be 38dB at 40kHz, it is assumed, if the customer's distance would exceed the 38dB for standard installation, the U-Repeater would be mounted within stated range of 34dB and the customer's length would be extended another 34dB from the U-Repeater installation point.

The customer will not be charged the ISDN BRI Individual Line Loop Extension rate unless the equipment is actually used. The charge will not be invoked based on the cable footage. The power module is designed to be used only with the U-Repeater and the repeater can only be used with the power module. The appropriate Individual Line Loop Extension rate will apply in addition to rates for Basic Rate Interface and Single Line Services.

22. Automatic Call Distribution - Management Information System (ACD/MIS)

- a. ACD/MIS is available to either existing or new ISDN-BRI customers.
- b. ACD/MIS will be furnished only from central offices that are technically capable and equipped for providing the service.
- c. Customers will be required to provide compatible customer premises equipment (CPE). Frontier makes no guarantees and assumes no liability associated with the customer's receipt of data if the CPE does not meet Frontier compatibility requirements.
- d. Customers must have the Basic ACD Feature Package before subscribing to the Advanced ACD/MIS features.
- e. Advanced ACD/MIS customers will need one MIS Data Link for each supervisor workstation access.
- f. Multipoint ACD/MIS customers can place two agents on one ACD line. Each agent uses one B channel and shares the D channel.

\* Integrated Services Digital Network – Basic Rate Interface is grandfathered and limited to existing customers at existing locations as of March 28, 2022. Moves, additions or changes will not be permitted.

(N)  
(N)

Effective: March 28, 2022

---

INTEGRATED SERVICES DIGITAL NETWORK (SDN) – PRIMARY RATE INTERFACE (PRI) /  
BASIC RATE INTERFACE (BRI)

III. SPECIAL CONDITIONS (Continued)

D. ISDN-BASIC RATE INTERFACE (BRI) SERVICES\* (Continued)

(C)

23. Exception Provisioning

- a. Exception Provisioning provides ISDN-BRI Service to customers served by a non-ISDN capable central office.
- b. The Exception Provisioning monthly rates will apply in addition to rates for Basic Rate Interface Services.
- c. The monthly rates for Exception Provisioning include a rate for provisioning and a rate for Special Transport mileage. The Special Transport mileage rate applies to provide the transmission facilities between the customer's serving central office and the ISDN capable office. There is no additional charge for Special Transport Termination.

E. ISDN-PRIMARY RATE INTERFACE (PRI) SERVICE

1. General

Integrated Services Digital Network-Primary Rate Interface (ISDN-PRI) Service provides digital access for integrated services between the customer's premises and the serving central office via a 1.544 Mbps facility. ISDN-PRI denotes an end-to-end digital network capable of supporting a combination of public and private network access services. ISDN-PRI is an alternative for individual access services, such as Two Way, Direct Inward Dialing (DID), Direct Outward Dialing (DOD), 800 Service, OutWATS Service, and local business trunks.

ISDN-PRI Service is available to customers where facilities permit. Customers must provide compatible premises switching equipment for terminating the D Channel and the 1.544 Mbps high capacity digital services facilities.

ISDN-PRI Service is typically divided in capacities of twenty-three 64 Kbps B Channels and one 64 Kbps D Channel (23B+D). The D Channel carries the out-of-band signaling required to control its associated B Channels on one or more 1.544 Mbps high capacity digital facilities where technology permits.

When requesting ISDN-PRI Service, the customer must specify the minimum and maximum number of channels to be used for exchange, access and data services as well as any other information needed for the Company to provide service.

The availability and functionality of ISDN-PRI features and capabilities may vary by serving central office.

The minimum subscription period for each ISDN-PRI Service is one month.

ISDN-PRI Service may be provided from a Frontier alternative central office if a customer's serving central office is not suitably equipped, or if the customer chooses to subscribe to service from a different Frontier central office. The customer may be required to utilize the telephone numbers and dialing plan associated with the designated ISDN-PRI central office. Additional charges for High Capacity Digital Facility and Special Transport will apply to the Switched Facility between the customer's serving central office and the ISDN-PRI capable central office, except when the ISDN-PRI capable central office is part of a Remote Switching Cluster, as defined in III.A.

\* Integrated Services Digital Network – Basic Rate Interface is grandfathered and limited to existing customers at existing locations as of March 28, 2022. Moves, additions or changes will not be permitted.

(N)  
(N)

Effective: April 1, 2016

---

INTEGRATED SERVICES DIGITAL NETWORK (SDN) - PRIMARY RATE INTERFACE (PRI) /  
BASIC RATE INTERFACE (BRI)

III. SPECIAL CONDITIONS (Continued)

E. ISDN-PRIMARY RATE INTERFACE (PRI) SERVICE (Continued)

1. General (Continued)

If a customer's ISDN-PRI Service interconnects with an Intermediary Customer (Interexchange Carrier or other service provider), PRI Access is permitted only within a single customer's ISDN-PRI Service arrangement. Access to the Telephone Company's exchange network or switched services is not permitted.

A primary telephone number is provided with each activated B Channel. Additional telephone numbers may be ordered for each B Channel. Additional telephone numbers for DID are available at the rates shown in this Section.

Network Usage charges apply to the Term Option of ISDN-PRI Service in the same manner as they apply to the Month-to-Month Option.

Termination Liability - Customers who subscribe to ISDN-PRI Service on the Term Option and terminate service prior to the anniversary date of the term commitment plan will be subject to termination liability charges. See Section 2.B.15 of this Product Guide, for termination liability terms and conditions. Termination Liability does not apply to optional features. The termination liability charge will not apply when a customer converts from PRI Access and Facility to a PRI Access only when the PRI is connecting to an alternate high capacity facility

2. Rate Elements

PRI Access Interface - PRI Access Interface provides the switch termination for the PRI Switched Facility. A PRI Access Interface is required to terminate to an ISDN-PRI serving central office. A PRI Access Interface typically provides twenty-three individual B Channels and one D Channel.

Switched Facility - The customer has a choice of service arrangements, (i.e., customer premises to local central office, local central office to alternative central office, or Tie Channel Services). The rates and charges for the Switched Facility will be based on the selected arrangement and will be comprised of one or a combination of the following rate elements:

a. Customer Premises to Local Central Office

Option 1 - PRI High Capacity Digital Facility plus Special Transport

Option 2 - Alternate High Capacity Digital Facilities from appropriate Company Tariff or Product Guide

b. Local Central Office to ISDN-PRI Capable Alternative Central Office

Option 1 - PRI High Capacity Digital Facility plus Special Transport per airline mile or Metro Ethernet Special Transport.

Option 2 - Alternate High Capacity Digital Facilities from appropriate Company Tariff or Product Guide

c. Tie Channel Services

Tie Channel Service to customer premises or central office to central office

Tie Channel Service to Intermediary Customer

Effective: April 1, 2016

---

INTEGRATED SERVICES DIGITAL NETWORK (SDN) - PRIMARY RATE INTERFACE (PRI) /  
BASIC RATE INTERFACE (BRI)

III. SPECIAL CONDITIONS (Continued)

E. ISDN-PRIMARY RATE INTERFACE SERVICE (Continued)

2. Rate Elements (Continued)

B Channel Configurations - B Channels can carry voice and circuit switched data at up to 64 Kbps for up to 24 B Channels. Channel activation monthly recurring charges will apply on a per channel basis. A primary telephone number is provided with each activated B Channel. Additional telephone numbers may be ordered for each PRI line. Additional telephone numbers for Two Way/DID/DOD Service are available at the rates specified in II. Rates and Charges.

Database Configurations - Nonrecurring charges for database configuration apply on a per service order basis for both the Month-to-Month Option and the Term Option of ISDN-PRI.

a. Month-to-Month Option - Database configuration charges for the Month-to-Month Option apply to both initial and subsequent service orders for the following rate elements:

- (1) PRI Access Interface, each
- (2) Channel, per type (regardless of quantity)

b. PRI Access Switched Facility System - Term Option - Database configuration charges for the Term Option apply per PRI Access Switched Facility System as follows:

- (1) Initial Service Order - Applicable per initial and subsequent orders of PRI Access Switched Facility System.
- (2) Subsequent Service Order - Applicable to all changes made to PRI Access Switched Facility System.

c. PRI Access System - Term and Volume Option - The Database Configuration Charge for Initial Service Order in II. Rates and Charges B.2.c.(1) does not apply for the initial order on a 1-, 2- or 3-Year Term and Volume Option or a 2- or 3-Year Corporate Rewards Plan. Database configuration charges for the Term and Volume Option or the 2- or 3-Year Corporate Rewards Plan apply to Subsequent Service Orders only, per PRI Access Switched Facility System.

d. Optional Features - Nonrecurring charges do not apply if optional features are ordered with initial ISDN-PRI installation. ISDN-PRI Centrex Access or ISDN-PRI VOIP Centrex Access nonrecurring charges as set forth in Section 11 of this Product Guide, A.7 or A.8 always apply. Tie Channels are in addition to the normal channel charges. If optional feature(s) is added to an existing PRI System, the Subsequent Service Order charge in II. Rates and Charges B.2.c.(2) will apply per PRI Access Switched Facility System.

PRI Access Switched Facility System Service is a bundled rate contract term offering of ISDN PRI Service. It includes support for the standard features listed in III. Special Conditions E.3, B channel configurations (except for Tie Channel Services), first telephone number per channel activated, and the DS1 High Capacity Facility at no additional cost.

Effective: April 1, 2016

---

INTEGRATED SERVICES DIGITAL NETWORK (SDN) - PRIMARY RATE INTERFACE (PRI) /  
BASIC RATE INTERFACE (BRI)

III. SPECIAL CONDITIONS (Continued)

E. ISDN-PRIMARY RATE INTERFACE SERVICE (Continued)

2. Rate Elements (Continued)

PRI Access Term and Volume Option or the 1-, 2- or 3-Year Corporate Rewards Plan include the PRI Access, standard features listed in III. Special Conditions E.3, B channel configurations (except for Tie Channel Services), and first telephone number per channel activated.

- a. Packages are available with or without the DS1 Switched Facility. Customers can select measured voice/data channels and unlimited local voice usage/measured calling plans.
- b. Term and Volume Option with Unlimited Local Calling will include unlimited local voice usage for direct dialed calls to Zones 1 and 2 and ZUM Zone 3.
- c. All of a customer's Company provided Term and Volume PRIs within the state will count towards the volume option threshold. Term and Volume option customers may change the number of PRIs during the volume term period. In the event that a customer on a Term and Volume option makes subsequent PRI increases or decreases that cause the total number of PRIs to fall within a different threshold level, all remaining PRIs will be billed at the applicable threshold level rate for the remainder of the term and volume period. The customer must provide the account information of the PRIs included in the Term and Volume option at the time of the initial installation of service and with each change to the service.
- d. ISDN-PRI Centrex Access or ISDN-PRI VOIP Centrex Access nonrecurring charges as set forth in Section 11 of this Product Guide always apply. Tie Channels are in addition to the normal channel charges.

Contracts - Customers with existing ISDN-PRI contracts may convert to a new contract option without incurring termination liability charges, provided the value of the new contract is equal to or greater than the remaining value of the existing contract option.

Tie Channel Service to Intermediary Customers - The rate for Tie Channel Service to Intermediary Customers applies only to ISDN-PRI facilities that extend from the ISDN-PRI serving central office to the Intermediary Customer. In order to send calls to the Intermediary Customer, local loop access from the customer's premises to the customer's ISDN-PRI serving central office is also needed (e.g., Centrex, Two Way, DID trunk, DOD trunk, or Call-by-Call trunk). ISDN-PRI Centrex Access or ISDN-PRI VOIP Centrex Access nonrecurring charges as set forth in Section 11 of this Product Guide always apply. Tie Channels are in addition to the normal channel charges.

Alternative Central Office - Both the Month-to-Month Option and the Term Option of ISDN-PRI Service may be provided from a Frontier alternative central office if a customer's serving central office is not suitably equipped, or if the customer chooses to subscribe to service from a different Frontier central office. The customer may be required to utilize the telephone numbers and dialing plan associated with the designated ISDN-PRI central office. Additional charges for High Capacity Digital Facility and Special Transport are applicable to the Switched Facility between the customer's serving central office and the ISDN-PRI capable central office, except when the ISDN-PRI capable central office is part of a Remote Switching Cluster, as defined in III.A. In Metro Ethernet designated serving areas, the Metro Ethernet Special Transport rate may be used in lieu of the rate for Special Transport per airline mile.

Effective: April 1, 2016

---

INTEGRATED SERVICES DIGITAL NETWORK (SDN) - PRIMARY RATE INTERFACE (PRI) /  
BASIC RATE INTERFACE (BRI)

III. SPECIAL CONDITIONS (Continued)

E. ISDN-PRIMARY RATE INTERFACE SERVICE (Continued)

3. Standard Features

Call-by-Call Access - A customer-specified arrangement of B Channels used to access services available in the ISDN-PRI serving central office switch. The customer will be allowed to mix dedicated services and Call-by-Call Access on the same ISDN-PRI Service. To utilize Call-by-Call Access, the customer must specify, at subscription time, the quantities of channels that will be utilized for a specific service on the ISDN-PRI Service. The B Channels will be assigned and billed the maximum quantity specified. With this feature, separate facilities are not required for individual services, such as DID/DIOD, WATS, 800 Services, and local switched access lines. Call-by-Call Access is included in the Term Option of ISDN-PRI at no additional charge. Intermediary Customer Services will not be provided on a Call-by-Call Access basis. Intermediary Customer Services require subscription to an interLATA Special Access Service.

Clear Channel Capability - Clear Channel Capability allows the customer to transport 64 Kbps over the PRI channels with no constraint on the quantity or sequence of bits using the "Bipolar with Eight Zero Substitution" method of providing bit sequence independence. A standard B Channel includes Clear Channel Capability.

D Channel Backup - In arrangements of two or more ISDN-PRI's, D Channel Backup provides enhanced continuity of service by allowing a D Channel of one ISDN-PRI to automatically take over for a failed D Channel of another ISDN-PRI. D Channel Backup is included in the Term Option of ISDN-PRI at no additional charge. D Channel Backup is not available with the Month-to-Month Option of ISDN-PRI.

Caller ID - Caller ID provides for the display of the incoming call station number.

Non-Facility Associated Signaling (NFAS) - NFAS allows the D Channel signaling entity to assign calls to channels on more than one interface (including the one containing the D Channel). The collection of these B Channels and the controlling D Channel is called a PRI group. Up to 20 DS1 Facilities can be assigned to a PRI group. NFAS is included in the Term Option of ISDN-PRI at no additional charge. NFAS is not available with the ISDN-PRI Month-to-Month Option of ISDN-PRI.

4. Optional Features

Calling Line Identification (CLID) with Name - CLID with Name allows the customer to have access to the Executive

Directory number and name of the calling party. Compatible CPE is required. CLID with Name is available only where facilities and conditions permit. CLID with Name is available on a Month-to-Month basis or on a 1, 2, 3, or 5 Year Term.

Two B Channel Transfer - The Two B Channel feature allows the CPE user to accept a call and to subsequently transfer the call to a user inside or outside the CPE. Both the incoming and outgoing B Channels are then released for another call. Two B Channel Transfer is available only where facilities and conditions permit.

Effective: March 28, 2022

---

INTEGRATED SERVICES DIGITAL NETWORK (SDN) - PRIMARY RATE INTERFACE (PRI) /  
BASIC RATE INTERFACE (BRI)

III. SPECIAL CONDITIONS (Continued)

E. ISDN-PRIMARY RATE INTERFACE SERVICE (Continued)

4. Optional Features(Continued)

PRI Station Detail Billing - Station Detail Billing provides individual station call details for all stations utilizing a customer's ISDN Primary Service at an account level on a monthly basis. Details are provided with the customer bill or via the Internet on Frontier's website.

PRI Station Detail Billing is only available with measured-rate service.

Individual PRI Station Call Detail is for informational purposes only. Exact billing information is located in the Measured Call Summary portion of the customer's bill.

The customer's ISDN Primary Service must be equipped with Calling Party Default Directory Number with the Calling Party Screening option. Customers will not have the option to change the Calling Party Number and CPN may not be deleted.

Customers will have the option to define a partial listing in the screening list. Specific call details will not be provided for stations not included in the screening list. The screening list may not include 800 numbers, fictitious numbers, private network numbers or Centrex Dialing Plan numbers defined in the screening tables.

Station Call Details will only be provided for valid telephone numbers within the switch providing the customer's ISDN Primary Service.

F. DIGITAL (ISDN) SINGLE LINE SERVICES\*

(C)

1. Digital (ISDN) Single Line Service is intended for customers requiring ISDN access on a single line basis. All terms and conditions associated with ISDN-Basic Rate Interface Services, except the condition specifying a minimum line requirement, apply to Digital (ISDN) Single Line Service.
2. Digital (ISDN) Single Line Service for business customers will be provided on a measured-rate basis for voice and data calling.
3. Customers who require intercom functionality may subscribe to Basic Rate Interface (BRI) Services. Business customers will be migrated to BRI through a subsequent order process.

G. DISCOUNTS FOR QUALIFYING ENTITIES

See the General Exchange Tariff, Schedule No. K-8 for qualifications and discounts for Schools, Libraries, Health Care Providers, and Community Based Organizations.

\* Digital (ISDN) Single Line Service is grandfathered and limited to existing customers at existing locations as of March 28, 2022. Moves, additions or changes will not be permitted.

(N)  
(N)

INTEGRATED SERVICES DIGITAL NETWORK (SDN) - PRIMARY RATE INTERFACE (PRI) /  
 BASIC RATE INTERFACE (BRI)

INTEGRATED SERVICES DIGITAL NETWORK (ISDN) – PRIMARY RATE INTERFACE (PRI) BUNDLED SERVICE

I. GENERAL

Integrated Services Digital Network (ISDN) - Primary Rate Interface (PRI) Bundle Service is an optional business package that provides a digital trunk with 23 B-channels for circuit switched voice and data and 1 D-Channel for signaling plus Caller ID and the option of Direct Inward Dialing (DID) numbers.

II. APPLICABILITY

Applicable to network services provided in accordance with Integrated Services Digital Network (ISDN) – Primary Rate Interface (PRI) Bundle Service standards.

III. TERRITORY

Within all exchange areas as those areas are defined by maps filed as part of this tariff.

IV. RATES AND CHARGES

	<u>Monthly Rate</u>	
<u>2-Year Term</u> <sup>1</sup>		
ISDN-PRI Bundle	\$934.23	(l)
ISDN-PRI Bundle with 20 DID Numbers	949.23	
ISDN-PRI Bundle with 50 DID Numbers	954.23	
ISDN-PRI Bundle with 100 DID Numbers	959.23	
<u>3-Year Term</u> <sup>1</sup>		
ISDN-PRI Bundle	\$768.91	(l)
ISDN-PRI Bundle with 20 DID Numbers	783.91	
ISDN-PRI Bundle with 50 DID Numbers	788.91	
ISDN-PRI Bundle with 100 DID Numbers	793.91	
<u>5-Year Term</u> <sup>1</sup>		
ISDN-PRI Bundle	\$686.25	(l)
ISDN-PRI Bundle with 20 DID Numbers	701.25	
ISDN-PRI Bundle with 50 DID Numbers	706.25	
ISDN-PRI Bundle with 100 DID Numbers	711.25	

<sup>1</sup> Nonrecurring Charges do not apply to the initial installation of an ISDN-PRI Bundle.



Effective: April 1, 2016

---

INTEGRATED SERVICES DIGITAL NETWORK (SDN) - PRIMARY RATE INTERFACE (PRI) /  
BASIC RATE INTERFACE (BRI)

INTEGRATED SERVICES DIGITAL NETWORK (ISDN) – PRIMARY RATE INTERFACE (PRI) BUNDLED SERVICE (Continued)

V. SPECIAL CONDITIONS

- A. ISDN PRI Bundle Service is available where technically feasible.
- B. The bundles are offered for 2-, 3- and 5-year term commitments. A termination fee of 50% of the Monthly Recurring Charges will incur for the remainder of the term commitment period.
- C. A customer may convert an existing term commitment to a new term commitment prior to the completion of the existing term without penalty. The customer will be charged a Subsequent Activity Charge for the change and will pay the current rates in effect for the term commitment chosen.
- D. When a customer's serving office is not suitably equipped and/or the customer chooses to subscribe to ISDN-PRI Service from another central office, the customer will utilize the dialing plan associated with the designated ISDN-PRI central office. For PRIs served from an alternate central office, the normal PRI rates will apply in addition to the charges for Special Transport Termination and Special Transport (Mileage).
- E. ISDN-PRI customers who are served from a foreign node may request to have their service provided from their local central office when facilities become available at that office. The Initial Service Ordering Charge and nonrecurring charges for T-1s and ports will be applicable, and termination charges will not apply on that transfer provided that the quantity of T-1s and ports are preserved. Customers who choose to continue service from a foreign node will be subject to the monthly rate for interoffice facilities. In addition, a number change generally will be required on any transfer from a foreign node to a local central office.
- F. Ports will be provided at the T-1 level only.
- G. Customer provided equipment used to connect to ISDN-PRI Bundle Service must meet Company requirements.
- H. The Company shall not be responsible to the customer if changes in any of the facilities, operations, or procedures utilized in the provision of ISDN-PRI Bundle Service render any equipment provided by a customer obsolete or require any modification or alteration of such equipment or system or otherwise affect its use or performance.
- I. The customer must subscribe to services and specify each type of traffic that will be transported across the ISDN-PRI Bundle Service port (i.e., DID, DOD). All rates and regulations for these services will apply. The bundle is offered as flat rate voice with measured data. Usage charges generated by using ISDN-PRI will be measured and billed in accordance with the rates specified in this tariff.
- J. Appropriate nonrecurring charges apply for installation of and changes to ports, T-1s and features ordered by the customer except as set forth in IV. Rates and Charges preceding

Effective: April 1, 2016

---

DIGITAL NETWORK SERVICES

TABLE OF CONTENTS

SHEET NO.

I. DIGITAL CHANNEL SERVICE – Grandfathered as of October 3, 2011	
A. Service Description	1
B. Digital Architecture	2
C. Definitions	2
D. General	3
E. Application of Rates	6
F. Types of Rates and Charges	8
G. Rates and Charges	10
III. CUSTOMER NETWORK CONTROL – Grandfathered prior to December 1, 2008	
A. Description of Service	15
B. Definitions	16
C. General	17
D. Application of Rates	19
E. Rates and Charges	21

Effective: April 1, 2016

---

DIGITAL NETWORK SERVICES

I. DIGITAL CHANNEL SERVICE <sup>1,2</sup>

A. SERVICE DESCRIPTION

1. Digital Channel Service is an intra-exchange multifunctional digital channel service which provides access transport between the customer's premises and the serving central office over a single high-capacity digital facility on a channelized basis.
2. Digital Channel Service is provided in capacity increments of 24 digital channels (DS0s) over a single DS1 facility.
3. The following network services may be furnished on a link (partial channel) basis across multiple jurisdictions when connected with Digital Channel Service.
  - Analog Voice Service (exchange line/trunks, Centrex, foreign exchange line, off premises extensions, voice private lines, tie lines, intrastate 800)
  - Analog Data Service
  - Digital Data Service (2.4, 4.8, 9.6, 19.2, 56 Kbps)
  - DS1 Service (1.544 Mbps)
  - Switched Data Service

4. Digital Channel Service is comprised of the following components.

Digital Channel Capacity  
Digital Channel Activation  
Service Activation  
Customer Premises Channelization  
Optional Service Activation  
Multi-Jurisdictional Access (Multi-J Intraoffice Channel Access, Multi-J Interoffice Channel Access)

Digital Channel Capacity, Digital Channel Activation and Service Activation will be provided at the rates and charges specified in Part I.G Rates and Charges of this section.

Customer Premises Channelization may be provided by the Company or by the customer. When provided by the Company, rates and charges specified in I.G Rates and Charges of this section will be applicable. When provided by the customer, terms and conditions specified in I.D of this section will apply.

<sup>1</sup> Effective October 3, 2011, Digital Channel Service is grandfathered and no longer available to new customers. Additions or changes to this service are permitted at existing customers locations only.

<sup>2</sup> Effective November 3, 2012, Digital Channel Service no longer allows moves, additions or changes to subscribers' existing service. Digital Channel Service continues to be available for resale until February 16, 2013, on which date the foregoing terms shall be effective for resale.

Effective: April 1, 2016

---

DIGITAL NETWORK SERVICES

I. DIGITAL CHANNEL SERVICE<sup>1,2</sup> (Continued)

B. DIGITAL ARCHITECTURE

Digital Channel Service differs in provisioning method and numbering format from end-to-end services. Services listed in I.A.3. of this section will be available from the Company on a link (partial channel) basis rather than on an end-to-end basis. This architecture is intended to promote efficient connectivity of analog and digital networks.

Multi-Jurisdictional Access (Multi-J Intraoffice Channel Access, Multi-J Interoffice Channel Access) Service Activation is an optional service that provides connectivity between the customer's serving central office and other carriers' points-of-presence in conjunction with the Digital Channel Service that provides connectivity between the customer's premises and central office. Multi-J activations are available on both an intraoffice and interoffice basis. These activations are available for both intraoffice and interoffice channel access and are required for each digital channel that the customer chooses to activate for digital channel network functionality at the central office. With these services, the customer is able to interconnect with other carriers for the provisioning of intraLATA or interLATA services.

Digital Channel Service will be available on a digital basis at the network interface located on the customer's premises. Digital Channel Service enables traditional analog services, such as tie lines, off-premises stations, and PBX trunks, to be provided on a digital basis when the customer desires them encoded in a DS1 bit stream. These traditionally analog services will be delivered to the customer's premises via DSO channels.

Both the Company and the customer have joint responsibilities to ensure proper transmission of the provided services. Normal analog channel network interface specifications will be superseded by electrical specifications for the 1.544 Mops (DS1) channel. Each DSO channel provided will have identity only as a "time slot" within a DS1 channel.

Compatible digital to analog conversion equipment must be provided to derive analog services, as required. Channelization at the customer premises may be provided by the Company or the customer.

C. DEFINITIONS

Digital Channel Capacity is a multifunctional DS1 signal between the customer premises and the serving central office. This digital link can be used to transport switched and dedicated services. Digital Channel Capacity is the transport medium for service activations ordered by the customer. Digital Channel Capacity is available in increments of 24 DS0s.

Digital Channel Activation is the quantity of channels activated at the serving central office. The quantity of Digital Channel activations cannot exceed the Digital Channel Capacity.

Service Activation is the connection between Digital Channel Service and the network service accessed.

Customer Premises Channelization provides the DS1 termination and DS1 demultiplexing to the DS0 level at the customer premises. Customer Premises Channelization utilizes D4 channel banks.

Channel Service Unit (CSU) is network channel terminating equipment used to terminate digital channel facilities at the customer premises.

<sup>1</sup> Effective October 3, 2011, Digital Channel Service is grandfathered and no longer available to new customers. Additions or changes to this service are permitted at existing customers locations only.

<sup>2</sup> Effective November 3, 2012, moves, additions or changes to subscribers' existing Digital Channel Service are not permitted. Digital Channel Service continues to be available for resale until February 16, 2013, on which date the foregoing terms shall be effective for resale.

Effective: April 1, 2016

---

DIGITAL NETWORK SERVICES

I. DIGITAL CHANNEL SERVICE<sup>1,2</sup> (Continued)

C. DEFINITIONS (Continued)

Optional Service Activation is an enhanced service activation over Digital Channel Service. Optional Service Activations are provided in conjunction with Analog or Digital Service Activations.

Direct Inward/Outward Dialing (DIOD) Optional Service Activation is a central office based service that permits incoming calls to reach customer-provided equipment without the assistance of an attendant and allows the trunk to be used to place outgoing calls. DIOD is provided in conjunction with Analog or Digital Service Activations.

DS0 denotes a channel service expressed in terms of its digitally encoded data bit rate in accordance with the North American hierarchy of digital signal levels. It is generally referred to as having a 64 Kbps transmission bit rate signal; however, customer transmitted bit rates are limited to 56 Kbps.

DS1 denotes a channel service expressed in terms of its digitally encoded bit rate in accordance with the North American hierarchy of digital signal levels. It has a 1.544 Mops transmission data rate and provides for the two-way simultaneous transmission of isochronous timed, Bipolar Return-to-Zero (BPRZ) bit stream format. Unframed signal formats are not permitted or compatible with Company equipment.

D. GENERAL

1. Digital Channel Service is furnished subject to the availability of facilities. Special Construction charges may apply.
2. 1.5 Special Transport Facility and mileage rates specified in the Facilities for Intrastate Access Tariff C-1, Section III.B will be applicable per Digital Channel Capacity when a customer requested Digital Channel Service must be provisioned in a central office other than the customer's serving central office.
3. The customer may activate any number of digital channels within the limitations set forth in D.6. following. Once activated, a digital channel is subject to a minimum service period.
4. All Digital Channel Service must be channelized in a single equipment location at the customer's premises. Digital Channel Service cannot be split between customer premises or delivered to multiple locations within a customer premises. Tie lines or extensions may be furnished on a link basis between multiple locations. Standard network interfaces will be provided by the Company for analog and digital services consistent with existing practices.
5. Individual digital channels (DSOs) may be activated and furnished on a link (partial channel) basis with services offered in other sections of this guide. Rates, charges, terms and conditions specified in this section are applicable to the Digital Channel Service component of the customer's end-to-end service. Rates, charges, terms and conditions in other sections of this guide are applicable to the customer's interconnected services (i.e., tie lines, private lines, special access lines, etc.), for the non-Digital Channel Service component of the end-to-end service.

<sup>1</sup> Effective October 3, 2011, Digital Channel Service is grandfathered and no longer available to new customers. Additions or changes to this service are permitted at existing customers locations only.

<sup>2</sup> Effective November 3, 2012, moves, additions or changes to subscribers' existing Digital Channel Service are not permitted. Digital Channel Service continues to be available for resale until February 16, 2013, on which date the foregoing terms shall be effective for resale.

Effective: April 1, 2016

---

DIGITAL NETWORK SERVICES

I. DIGITAL CHANNEL SERVICE<sup>1,2</sup> (Continued)

D. GENERAL (Continued)

6. The total number of digital channels activated by the customer may not at any time exceed the total Digital Channel Capacity.
7. Central office channelization, which is a component of Digital Channel Capacity, generally provides analog to digital conversion to permit individual exchange services and private line channel services to be transported over digital high capacity facilities. Channelization is also intended for use at Company or customer locations where different high capacity digital network links terminate in the same central office and must be converted to individual analog or digital channels before individual service links can be cross-connected. Digital Channel Capacities are provided in groups of 24 DSO channels, and are subject to the limits as set forth in D.6 above.
8. Customer Premises Channelization generally provides analog to digital conversion at the customer premises. This allows individual exchange services and private line services to be transported over digital high capacity facilities. The termination of this channelization will be in a single equipment location at the customer premises. When Customer Premises Channelization is provided by the Company, the customer must provide suitable floor space, controlled environment, and a source of non-switched 120 volt, 60 Hz, AC power to support this service. Emergency backup power and ring generating equipment capabilities are available for an extra charge on an individual case basis.
9. Channelization at the customer premises may be provided by the customer or the Company. Joint provisioning of channelized services introduces joint responsibilities between the customer and the Company.
  - a. Responsibilities of the Company
    - (1) The Company will endeavor to activate its portion of joint service in a timely manner on the negotiated date to support installation requirements.
    - (2) The Company will provide the customer with information regarding the type and the manufacturer of central office channelization equipment to be used in each application.
    - (3) The Company reserves the right to change its equipment vendors should equipment availability, price or technological advantages make such a change attractive or necessary.
    - (4) The Company will notify the customer, generally a minimum of six months in advance, of any need to change its central office equipment to allow the customer sufficient time to respond, make any necessary changes, and schedule cooperative testing for cutover if required.
    - (5) Digital synchronization timing for Digital Channel Service will be provided by the Company.
  - b. Responsibilities of the Customer
    - (1) The customer must be prepared to activate his portion of joint service in a timely manner on the negotiated date, providing testing equipment and personnel to support installation requirements, as may be necessary.
    - (2) Customer equipment must be compatible with Company provided channelization at the central office.

<sup>1</sup> Effective October 3, 2011, Digital Channel Service is grandfathered and no longer available to new customers. Additions or changes to this service are permitted at existing customers locations only.

<sup>2</sup> Effective November 3, 2012, moves, additions or changes to subscribers' existing Digital Channel Service are not permitted. Digital Channel Service continues to be available for resale until February 16, 2013, on which date the foregoing terms shall be effective for resale.

Effective: April 1, 2016

---

DIGITAL NETWORK SERVICES

I. DIGITAL CHANNEL SERVICE<sup>1,2</sup> (Continued)

D. GENERAL (Continued)

9. Channelization at the customer premises may be provided by the customer or the Company. Joint provisioning of channelized services introduces joint responsibilities between the customer and the Company. (Continued)

c. Trouble Resolutions

The Company will assist the customer in resolving any installation or day to day channel service problems. However, the Company does not assume responsibility for the compatibility or suitability of the customer's equipment. Premises Visit Charges as set forth in I.G following will be applied when an employee is dispatched at the customer's request to the customer's premises for the purpose of locating trouble and the trouble is caused by customer provided equipment.

10. When the Company provides Digital Channel Service channelization equipment at a customer premises, it is not necessary for the customer to provide Channel Service Units (CSUs) for associated channels.
11. Channelized DS1 service is available only with D4 channel bank equipment or compatible, equivalent equipment.
12. Certain technology, such as low bit rate voice multiplexing techniques, may permit additional quantities of individual channels to be channelized on a single DS1 signal. Equipment providing this capability does not generally assure compatibility between different manufacturers. Some equipment may not be suitable for data transmission of tandem network line application. Rates, charges, and availability of this equipment will be negotiated with the customer on individual case basis.
13. When a customer's Digital Channel Service is interrupted due to any cause other than the negligence or willful act of the subscriber or the failure of the facilities provided by the subscriber, a pro rata adjustment of the monthly charges involved will be allowed automatically for the service and facilities rendered useless and inoperative by reason of the interruption during the time said interruption continues in excess of 24 hours from the time it is reported to or detected by the Company except as otherwise specified in this section. The adjustment shall not be applicable for the time that the Company stands ready to repair the service and the subscriber does not provide access to the Company for such restoration work.
14. End User common Line Charges as authorized by the FCC and Joint Board will apply to Digital Channel Service. For each channel within a Digital Channel Capacity, an End User Common Line Charge will apply.
15. Switched Data Service, when used in conjunction with DCS, will be furnished only where facilities are available. Service is offered on a limited basis by specific switching systems within certain geographical areas. Since this service is not offered in all areas, it is important to verify its availability by contacting your Frontier Account Representative or Business Office at the telephone number listed in your telephone directory under the heading "WHERE TO REACH FRONTIER", for Installation/Service.
16. Customers must purchase blocks of Direct Inward Dialing (DID) numbers in Section 4, Local Exchange Service.

<sup>1</sup> Effective October 3, 2011, Digital Channel Service is grandfathered and no longer available to new customers. Additions or changes to this service are permitted at existing customers locations only.

<sup>2</sup> Effective November 3, 2012, moves, additions or changes to subscribers' existing Digital Channel Service are not permitted. Digital Channel Service continues to be available for resale until February 16, 2013, on which date the foregoing terms shall be effective for resale.

Effective: April 1, 2016

---

DIGITAL NETWORK SERVICES

I. DIGITAL CHANNEL SERVICE<sup>1,2</sup> (Continued)

E. APPLICATION OF RATES

1. The following rate elements are applicable to Digital Channel Service:

Digital Channel Capacity  
Digital Channel Activation  
Service Activation

In addition, rates and charges for Customer Premises Channelization apply where channelization equipment is provided by the Company at the customer premises. Measured Rate Service-Local Calling Rates set forth in Section 4 of this Product Guide, Local Exchange Service apply when exchange and long-distance calling is provided in connection with Digital Channel Service.

2. Digital Channel Capacity

The Digital Channel Capacity rate will apply for transport and central office channelization. Customers will select capacity in increments of 24 digital channels.

Monthly rates and charges for Digital Channel Capacity apply according to the requested channel capacity. These rates apply regardless of the number of digital channels actually activated. The minimum service period for Digital Channel Capacity is 12 months.

3. Digital Channel Activation

The Digital Channel Activation rate will apply for each digital channel (DSO) activated within the Digital Channel Capacity.

4. Service Activation

The Service Activation rate will apply on a per channel basis to each network service (switched or dedicated) requested by the customer.

When Digital Channel Service facilities are used to transport DS1 Service, the DS1 Service Activation rate is applied in lieu of the Digital Channel Activation rate. DS1 Service Activation can only be ordered when provided in conjunction with other service activations.

In addition to Service Activation rates, Measured Rate Service Local Calling Rates described in I.E.5 following may apply.

<sup>1</sup> Effective October 3, 2011, Digital Channel Service is grandfathered and no longer available to new customers. Additions or changes to this service are permitted at existing customers locations only.

<sup>2</sup> Effective November 3, 2012, moves, additions or changes to subscribers' existing Digital Channel Service are not permitted. Digital Channel Service continues to be available for resale until February 16, 2013, on which date the foregoing terms shall be effective for resale.



Effective: April 1, 2016

---

DIGITAL NETWORK SERVICES

I. DIGITAL CHANNEL SERVICE<sup>1,2</sup> (Continued)

E. APPLICATION OF RATES (Continued)

5. Measured Rate Service-Local Calling Rates

Rates listed in Section 4 of this Product Guide, Local Exchange Service, Measured Rate Service-Local Calling Rates, will apply to each Service Activation that utilizes basic exchange access from the serving central office, with the exception of foreign exchange service and 800. These rates are in addition to other applicable Digital Channel Service rates and charges.

6. Customer Premises Channelization

Customer Premises Channelization is optional. When provided by the Company, Customer Premises Channelization Digital Channel Capacity and Customer Premises Service Activation rates as set forth in I.F following will apply.

7. Rates and charges specified in other sections of this guide for services connected to or extended beyond Digital Channel Service (i.e., Touch-Tone, Business Shared Private Line, off-premises stations, tie lines, private lines, etc.) are in addition to rates specified for Digital Channel Service. This includes Nonrecurring Charges for activities involving the non-Digital Channel Service portion of the end-to-end service.

8. Transfer of service responsibility between customers is permitted subject to the rules and regulations specified in the General Exchange Tariff, Schedule No. D&R, Rule No. 8. Charges specified in I.F.2 will apply.

9. 1.5 Special Transport Facility and mileage rates specified in the Facilities for Intrastate Access Tariff C-1, Section III.B will apply per Digital Channel Capacity for interconnection between Digital Channel Services provisioned from two or more central offices. These rates will apply in addition to Digital Channel Service rates for each premises for which Digital Channel Service is provisioned.

10. Optional Service Activation monthly rates are in addition to rates for Analog or Digital Service Activation. A nonrecurring charge will not be applicable if service is ordered at the time an order for DCS is placed. If customer orders an Optional Service Activation subsequent to DCS, a Configuration Charge will be applied.

<sup>1</sup> Effective October 3, 2011, Digital Channel Service is grandfathered and no longer available to new customers. Additions or changes to this service are permitted at existing customers locations only.

<sup>2</sup> Effective November 3, 2012, moves, additions or changes to subscribers' existing Digital Channel Service are not permitted. Digital Channel Service continues to be available for resale until February 16, 2013, on which date the foregoing terms shall be effective for resale.

Effective: April 1, 2016

---

DIGITAL NETWORK SERVICES

I. DIGITAL CHANNEL SERVICE<sup>1,2</sup> (Continued)

F. TYPES OF RATES AND CHARGES

There are two basic types of rates and charges that apply to Digital Channel Service; monthly rates and nonrecurring charges.

1. Monthly Rates

Monthly rates are recurring charges that apply each month or fraction thereof. For billing purposes, each month is considered to have 30 days.

2. Nonrecurring Charges

Nonrecurring charges are one time charges that apply for specific work activity (i.e., installation of service or change to an existing service). The following types of nonrecurring charges apply for Digital Channel Service.

a. Service Ordering Charges

- (1) Service Establishment Charge - This charge applies to the initial Digital Channel Capacity(s) ordered by a customer for receiving, recording and processing the request for service. This charge includes processing orders to establish initial Digital Channel and Service Activations and/or Company provided Customer Premises Channelization. This charge includes common centralized testing, coordination and accounting activities.

This charge also applies to subsequent orders received to establish additional Digital Channel Capacity(s) and Customer Premises Channelization.

- (2) Service Change Charge - This charge applies on a per Digital Channel Capacity basis (increments of 24 channels) associated with a customer request for modifications to an existing Digital Channel Service. This would include activities such as but not limited to the following:

- Inside Move
- Change name, same customer
- Administrative record changes

- (3) Configuration Charge - This charge applies on a per occurrence basis to customer requests for modifications to existing service. This includes activities such as, but not limited to, the following:

- Change of associated channel assignment
- Additions of supplemental features
- Activate/deactivate Digital Channel Activations
- Activate/deactivate Service Activations

<sup>1</sup> Effective October 3, 2011, Digital Channel Service is grandfathered and no longer available to new customers. Additions or changes to this service are permitted at existing customers locations only.

<sup>2</sup> Effective November 3, 2012, Digital Channel Service no longer allows moves, additions or changes to subscribers' existing service. Digital Channel Service continues to be available for resale until February 16, 2013, on which date the foregoing terms shall be effective for resale.

Effective: April 1, 2016

---

DIGITAL NETWORK SERVICES

I. DIGITAL CHANNEL SERVICE<sup>1,2</sup> (Continued)

F. TYPES OF RATES AND CHARGES (Continued)

2. Nonrecurring Charges (Continued)

b. Premises Visit Charge

This charge applies on a per visit basis for the termination or rearrangement of facilities at the customer premises. Only one charge applies when more than one channel is terminated or rearranged at the same time.

This charge applies to inside moves as specified in I.F.2.e following.

This charge also applies when a Company representative is dispatched to a customer premises for the purpose of locating trouble and the trouble is caused by customer equipment as stated in I.D.9.c preceding.

c. Installation of Digital Channel Service

These are nonrecurring charges associated with work performed by the Company in connection with physical installation activities involving central office and/or outside plant facilities. These charges apply to initial installation requests and to requests for additional terminations to existing service.

In addition to these charges, the appropriate Service Ordering Charge will apply.

d. Service Rearrangements

Service Rearrangements are changes to existing (installed) services which may be administrative only in nature or involve an actual physical change to the service.

In cases where multiple service rearrangements or an additional termination or a move and a rearrangement are requested by the customer, the total charge will never exceed the full nonrecurring charge for the initial service.

(1) Changes in ownership or transfer of responsibility from one customer to another requires the discontinuance of service and the start of new service. A new Term Payment Plan will also be applicable. The Service Establishment Charge and any appropriate minimum period charges will apply.

(2) Changes in the physical location of the point of termination are treated as Moves which are described and charged for as set forth in I.F.2.e following.

(3) Changes to existing services for the establishment of Digital Channel Service will require a discontinuance of service and establishment of new service. All applicable nonrecurring and recurring charges for the establishment of Digital Channel Service will apply.

<sup>1</sup> Effective October 3, 2011, Digital Channel Service is grandfathered and no longer available to new customers. Additions or changes to this service are permitted at existing customers locations only.

<sup>2</sup> Effective November 3, 2012, moves, additions or changes to subscribers' existing Digital Channel Service are not permitted. Digital Channel Service continues to be available for resale until February 16, 2013, on which date the foregoing terms shall be effective for resale.

Effective: April 1, 2016

---

DIGITAL NETWORK SERVICES

I. DIGITAL CHANNEL SERVICE<sup>1,2</sup> (Continued)

F. TYPES OF RATES AND CHARGES (Continued)

2. Nonrecurring Charges (Continued)

e. Moves

A move involves a change in the physical location of the point of termination at the customer premises. The charge for the move depends on whether the move is within the same customer premises (same address and/or same building) or to a different customer premises (different address and different building).

(1) Inside Move is a move to a new point within the same customer premises. The charge for the move will be the Service Change Charge, Premises Visit Charge, and an amount equal to one half the nonrecurring charge per Digital Channel Capacity (per group of 24 Digital Channels) terminations(s) affected.

(2) Outside Move is a move to a different customer premises and will be treated as a disconnect and an installation of new service. The Service Establishment Charge will apply in addition to all applicable nonrecurring charges for the service terminations(s) affected. A new Term Payment Plan will be established for the installed service. The customer will remain responsible for all minimum period charges and Termination Liability charges associated with the disconnected service(s).

G. RATES AND CHARGES

1. Nonrecurring Charges

a. Service Establishment Charge

Initial	\$150.00
Subsequent	150.00

b. Service Change Charge

Per Digital Channel Capacity Each, increment of 24 channels	108.00
--	--------

c. Configuration Charge

Per Occurrence	50.00
----------------	-------

d. Premises Visit Charge

Per Visit, Each	35.00
-----------------	-------

<sup>1</sup> Effective October 3, 2011, Digital Channel Service is grandfathered and no longer available to new customers. Additions or changes to this service are permitted at existing customers locations only.

<sup>2</sup> Effective November 3, 2012, moves, additions or changes to subscribers' existing Digital Channel Service are not permitted. Digital Channel Service continues to be available for resale until February 16, 2013, on which date the foregoing terms shall be effective for resale.

Effective: April 1, 2016

---

DIGITAL NETWORK SERVICES

I. DIGITAL CHANNEL SERVICE<sup>1,2</sup> (Continued)

G. RATES AND CHARGES (Continued)

2. Digital Channel Capacity

a. Per System	Nonrecurring <u>Charge</u>	Monthly <u>Rate</u>
24 Digital Channels	\$300.00	\$770.00
48 Digital Channels	550.00	1,014.00
72 Digital Channels	800.00	1,255.00
96 Digital Channels	1,050.00	1,417.00
120 Digital Channels	1,300.00	912.00
144 Digital Channels	1,550.00	1,735.00
192 Digital Channels	2,050.00	1,199.00
240 Digital Channels	2,550.00	1,374.00
288 Digital Channels	3,050.00	1,615.00
384 Digital Channels	4,050.00	2,101.00
480 Digital Channels	5,050.00	2,587.00
576 Digital Channels	6,050.00	3,076.00
672 Digital Channels	7,050.00	3,560.00
1344 Digital Channels	14,050.00	5,807.00
2016 Digital Channels	15,500.00	7,608.00

b. Digital Interoffice Transport

Refer to the Facilities for Intrastate Access Tariff C-1, Section III for rates.

<sup>1</sup> Effective October 3, 2011, Digital Channel Service is grandfathered and no longer available to new customers. Additions or changes to this service are permitted at existing customers locations only.

<sup>2</sup> Effective November 3, 2012, moves, additions or changes to subscribers' existing Digital Channel Service are not permitted. Digital Channel Service continues to be available for resale until February 16, 2013, on which date the foregoing terms shall be effective for resale.

Effective: April 1, 2016

---

DIGITAL NETWORK SERVICES

I. DIGITAL CHANNEL SERVICE <sup>1,2</sup> (Continued)

G. RATES AND CHARGES (Continued)

	<u>Nonrecurring Charge</u>	<u>Monthly Rate</u>
3. Digital Channel Activation <sup>1</sup>		
Per Digital Channel Activated	\$6.00	\$1.50
4. Service Activations - Per Network Service		
a. Analog Service Exchange Line / Trunk)	32.00	4.00
Centrex Station Line	32.00	5.50
b. Foreign Exchange, Off Premises Extension, Private Line, Tie Line, Intrastate Watts/800	35.00	14.00
c. Digital Data Service 2.4 Kbps, 4.8 Kbps, 9.6 Kbps, 19.2 Kbps	35.00	30.00
d. Digital Data Service 56 Kbps	35.00	39.70
e. DS1 Service 1.544 Mbps	500.00	69.70
f. Switched Data Service <sup>2</sup>	35.00	10.00

<sup>1</sup> Does not apply to DS1 Service.

<sup>2</sup> Network Usage rates will be billed in accordance with rates and conditions for local, ZUM, and IntraLata Toll Service calls as set forth in Sections 4, 5, and 28 of this Product Guide.

<sup>3</sup> Effective October 3, 2011, Digital Channel Service is grandfathered and no longer available to new customers. Additions or changes to this service are permitted at existing customers locations only.

<sup>4</sup> Effective November 3, 2012, moves, additions or changes to subscribers' existing Digital Channel Service are not permitted. Digital Channel Service continues to be available for resale until February 16, 2013, on which date the foregoing terms shall be effective for resale.

Effective: April 1, 2016

DIGITAL NETWORK SERVICES

I. DIGITAL CHANNEL SERVICE<sup>1,2</sup> (Continued)

G. RATES AND CHARGES (Continued)

5. Measured Rate Service-Local Calling Rates

Applies to Service Activations - Analog Service listed in G.4.a. preceding. Refer to Section 4 of this Product Guide, Local Exchange Service for usage rates.

6. Customer Premises Channelization - Company Provided on Customer Premises

a. Digital Channel Capacity

	<u>Nonrecurring Charge</u>	<u>Monthly Rate</u>	<u>Rate Ceiling</u>
24 Digital Channels	N/A	\$296.00	\$296.00
48 Digital Channels	N/A	332.00	332.00
72 Digital Channels	N/A	477.00	477.00
96 Digital Channels	N/A	514.00	514.00
120 Digital Channels	N/A	658.00	658.00
144 Digital Channels	N/A	694.00	694.00
192 Digital Channels	N/A	1,001.00	1,001.00
240 Digital Channels	N/A	1,183.00	1,183.00
288 Digital Channels	N/A	1,363.00	1,363.00
384 Digital Channels	N/A	1,877.00	1,877.00
480 Digital Channels	N/A	2,365.00	2,365.00
576 Digital Channels	N/A	2,727.00	2,727.00
672 Digital Channels	N/A	3,240.00	3,240.00
1344 Digital Channels	N/A	6,584.00	6,584.00
2016 Digital Channels	N/A	9,724.00	9,724.00

<sup>1</sup> Effective October 3, 2011, Digital Channel Service is grandfathered and no longer available to new customers. Additions or changes to this service are permitted at existing customers locations only.

<sup>2</sup> Effective November 3, 2012, moves, additions or changes to subscribers' existing Digital Channel Service are not permitted. Digital Channel Service continues to be available for resale until February 16, 2013, on which date the foregoing terms shall be effective for resale.

Effective: April 1, 2016

DIGITAL NETWORK SERVICES

I. DIGITAL CHANNEL SERVICE <sup>1,2</sup> (Continued)

G. RATES AND CHARGES (Continued)

6. Customer Premises Channelization - Company Provided on Customer Premises (Continued)

b. Service Activation, Per Channel

	<u>Nonrecurring Charge</u>	<u>Monthly Rate</u>	<u>Rate Ceiling</u>
(1) Analog Service Exchange Line/Trunk, Centrex Station Line	\$20.00	\$8.15	\$10.35
(2) Foreign Exchange, Off Premises Extension, Private Line, Tie Line, Intrastate WATS <sup>3</sup> /800	20.00	8.15	10.35
(3) Digital Data Service 2.4 Kbps, 4.8 Kbps, 9.6 Kbps, 19.2 Kbps	20.00	23.85	26.45
(4) Digital Data Service 56 Kbps	20.00	32.35	35.65
(5) Switched Data Service	20.00	30.00	34.50

7. Optional Service Activation <sup>1</sup>

a. Direct Inward/Outward Dialing (DIOD) <sup>2</sup> Two-way Trunk, per channel	--	5.00	
b. Multi-Jurisdictional Access <sup>1</sup>			
Multi-J Intraoffice Channel Access	--	4.00	
Multi-J Interoffice Channel Access	--	7.00	

<sup>1</sup> Optional service activation rates are in addition to Service Activation rates in Section I.Rates and Charges G.

<sup>2</sup> Customer must purchase blocks of DID numbers in Section 4 of this Product Guide.

<sup>3</sup> Effective October 3, 2011, Digital Channel Service is grandfathered and no longer available to new customers. Additions or changes to this service are permitted at existing customers locations only.

<sup>4</sup> Effective November 3, 2012, moves, additions or changes to subscribers' existing Digital Channel Service are not permitted. Digital Channel Service continues to be available for resale until February 16, 2013, on which date the foregoing terms shall be effective for resale.



---

DIGITAL NETWORK SERVICES

II. CUSTOMER NETWORK CONTROL<sup>1</sup>

A. Description of Service

1. Customer Network Control (CNC) Service provides customers flexibility in managing and reconfiguring their special service networks. CNC Service is a central office based service which enables customers to electronically reconfigure their Private Line Services from one line to any other qualified line controlled from a single customer's location. The reconfiguration will be accomplished by use of a Network Controller and a Digital Cross-connect System.

CNC Service includes real-time monitoring and reconfiguration of DS1s and voicegrade/digital private lines equipped with Digital Cross-connect Terminations without the direct intervention of the Company's personnel.

2. A list of available CNC Service features will be provided to the customer. These features may include, but are not limited to, the following:

Automatic Reconfiguration - The Network Controller may be programmed to automatically transfer critical circuits to an alternative facility should the primary route experience a network outage.

Loopback Capability - The customer may perform a full duplex loopback of any circuit terminating via the Digital Cross-connect System. This is of value for fault isolation and expediting network restoration.

Network Performance Reports - The Network Controller generates reports such as network alarms, outages, overall facility performance, and customer activity.

Reconfiguration on Demand - Circuit connections may be forced into, or out-of-service as required by the customer.

Security - The Network Controller offers multi-level security for access and network management activity.

Time of Day Reconfiguration - Network reconfigurations may be scheduled to go into effect at a predetermined time. They may be singular or periodic.

<sup>1</sup> Customer Network Control is limited to current customers. No new orders will be accepted for this service prior to December 1, 2008.

---

DIGITAL NETWORK SERVICES

II. CUSTOMER NETWORK CONTROL<sup>1</sup> (Continued)

B. Definitions

Channel Termination - A Channel Termination is the termination of a Private Line Service or Digital Channel Service on the Digital Cross-connect System.

CNC Service Arrangement - A CNC Service Arrangement consists of all the CNC Service elements a customer subscribes to, or serves as an agent for, including at least one Network Controller.

Digital Cross-connect System - The Digital Cross-connect System provides per channel DSO electronic cross-connection and provides test access for digital signals transmitted at the DS1 rates. It can connect multiples of up to 24 DSO circuits. Although the architecture of the Digital Cross-connect System requires a DS1 termination, the Company also offers Channel Terminations for other customer services (voicegrade, Digital Data Services/DDS-type, Digital Channel Services).

DS0 - "DS0" refers to a North American hierarchy of Digital Signal Levels. It means Digital Signal Level-0 is a 64 Kbps signal. The customer bit rates are limited to a 56 Kbps signal.

DS1 - "DS1" refers to a North American hierarchy of Digital Signal Levels. It means Digital Signal Level I, which is a 1.544 Mops signal.

Graphic Interface - The Graphic Interface is available as a feature via the Network Controller. It offers a graphical depiction of the customer's network as well as screen management features. The Graphic Interface requires a customer-owned personal computer with VGA graphics capability and presentation software.

Network Access Port - The Network Access Port provides the transmission path on either a dedicated or dial-up basis for the customer to transmit reconfiguration instructions or receive monitoring information from the Company's Network Controller.

Network Controller - The Network Controller performs the end-to-end coordination of each reconfiguration request and compiles network management reports. The Network Controller resides on the Company's premises and may be accessed directly by a remote, customer-owned terminal. This requires either a dedicated or dial-up access signalling channel.

Reconfiguration - A reconfiguration occurs whenever a Digital Cross-connect System cross-connects a channel-to one or more other channels.

Security Key - A security gate is provided for dial-up access to the network controller. This employs a challenge/response security key for the personal identification of authorized CNC users. Security keys are available in portable, hand-held or computer-based versions, at the customer's option.

<sup>1</sup> Customer Network Control is limited to current customers. No new orders will be accepted for this service prior to December 1, 2008.

Effective: April 1, 2016

---

DIGITAL NETWORK SERVICES

II. CUSTOMER NETWORK CONTROL<sup>1</sup> (Continued)

C. General

1. CNC Service is furnished only from central offices equipped with Digital Cross-connect Systems and is subject to the availability of appropriate equipment and facilities. If such equipment, new facilities, or changes to existing facilities are required for the provision of this service, a special construction charge may apply in addition to the rates for CNC Service.
2. CNC Service is furnished in conjunction with various Private Line Services and Digital Channel Service. The need to coordinate CNC Service installation with these services may result in an extension of the standard provisioning intervals for related service orders. The customer may connect intrastate interLATA services to the same customer's CNC Service Arrangement. The customer shall be responsible for the ordering of intrastate interLATA services.
3. Private Line Services that are cross-connected by CNC Service must have identical technical characteristics to ensure compatibility and proper operation. If the Company determines that the requested technical specifications are not compatible, the customer will be advised and given the opportunity to change the order. The Company will advise as to circuit compatibility, but shall not be responsible for service interruptions, trouble reports, circuit performance, loss of customer data, etc., resulting from invalid reconfiguration attempts on the part of the customer. A channel service compatibility list will be made available to the customer on request.
4. Due to the nature of CNC Service it may be necessary to perform preventative and routine maintenance on the system. This will mean that the Network Controller will be unavailable for service reconfiguration during these periods of time. Any services which are working will continue in operation, only the reconfiguration capability will not be usable. It may also be necessary to periodically take the CNC Service system out of service for software updates and other maintenance. In these cases, the customers will be notified in advance as to the time and duration of these outages.
5. A CNC Service Arrangement consists of the Network Controller, Network Access Ports, Graphic Interface and Digital Cross-connect Terminations.
6. Digital Cross-connect Terminations are applicable to DS1 terminations and voicegrade channel terminations. Digital Channel Services and Digital Data Services/DDS-type services will be provisioned without assessment of this charge.
7. CNC Service is available in conjunction with Private Line Services between a customer premises and local serving office and between two Digital Cross-connect System equipped central offices. When the customer's local serving office is not Digital Cross-connect System equipped, interoffice channel mileage rates will be applied as specified in II.D.8. following.
8. CNC Service may be combined with Digital Channel Service from this Product Guide. All CNC Service rates and charges will apply except the Digital Cross-connect Termination charges, as specified in II.E.1 and II.E.2. following. When a Digital Channel Service customer subscribes to CNC, a Service Establishment charge applies.
9. The customer has the option of purchasing additional Network Access Ports to the Network Controller for additional terminals. Terminals may utilize either dedicated or dial-up access. The application of rates specified in II.D.3 following will apply.

<sup>1</sup> Customer Network Control is limited to current customers. No new orders will be accepted for this service prior to December 1, 2008.

Effective: April 1, 2016

---

DIGITAL NETWORK SERVICES

II. CUSTOMER NETWORK CONTROL<sup>1</sup> (Continued)

C. General (Continued)

10. As required, Company assistance will be available on a call-in basis to assist customers with recovery from major service outages. This assistance may involve on-line customer support or service reconfigurations performed by the Company at the direction of the customer. This assistance is intended for abnormal service interruptions and will not serve as a substitute for normal trouble reporting and repair procedures.
11. The rates, terms and conditions specified herein for CNC Service are in addition to applicable rates, terms and conditions for the various services subscribed to in other sections of this Product Guide or other appropriate Tariffs.
12. A minimum service period of six months is required for CNC Service Arrangement rate elements.
13. Notice of discontinuance must be given by the customer at least thirty (30) days prior to actual discontinuance. Monthly charges will apply for a period of thirty (30) days from the date the Company receives discontinuance notification or until the requested discontinuance date, whichever period is longer.
14. The customer may transmit reconfiguration instructions or receive monitoring information from the Company's Network Controller on either a dedicated or dial-up basis. Dedicated access to the Network Controller via a private line arrangement must be purchased from the appropriate Product Guide.
15. CNC Service is partitioned on a single user and feature basis, assuring security for the customer as well as the Company's network.
16. Multiple customers may include their circuits with Digital Cross-connect Terminations in the same single user CNC Service Arrangement, provided all customers designate in writing the same single user to serve as their agent.
17. A CNC Service Arrangement consists of all qualified channel terminations for cross-connections terminating on the Digital Cross-connect System that can be monitored and reconfigured through a single customer user partition. These terminations may be connected individually, or in groups of channels.
18. Reconfiguration provides the customer with the ability to electronically direct the Company to connect or disconnect channel terminations in central offices where the customer has subscribed to CNC Service.
19. The customer will be responsible for providing terminal equipment, customer site modems, presentation or communications software, wire and cable on the customer's side of the demarcation point, dedicated access or dial-up service to access the Company's Network Controller.
20. CNC Service employs a multi-level security system to ensure the privacy and integrity of customer networks. To access the Network Controller, the customer must enter a log-in ID and a password, which is defined by the customer, and requires periodic revision by the customer. Log-in ID and password protection is the responsibility of the customer.
21. A customer may only control channels which are terminated in a Digital Cross-connect System equipped central office. A customer can control only those channels within the assigned CNC Service Arrangement/partition.

<sup>1</sup> Customer Network Control is limited to current customers. No new orders will be accepted for this service prior to December 1, 2008.

Effective: April 1, 2016

---

DIGITAL NETWORK SERVICES

II. CUSTOMER NETWORK CONTROL<sup>1</sup> (Continued)

C. General (Continued)

22. A CNC Service customer may have multiple terminals for accessing the Network Controller. The Company's network administrator must have access to the Network Controller database for maintenance and administrative purposes. If the customer reports a trouble and it is determined the problem resides in customer provided equipment, a Visit Charge will be applicable as defined in Section 3 of this Product Guide.
23. When service is interrupted due to a failure or malfunction in a CNC Service arrangement and the reconfiguration capability is unavailable, a pro rata adjustment of the CNC Service elements monthly charge will be allowed in accordance with the terms and conditions specified in Section 2 of this Product Guide.
24. No allowances will be granted for interruptions required to perform preventive or routine maintenance as indicated in II.C.4. preceding or to perform software updates when the customer is notified at least 24 hours prior to such occurrences.

D. Application of Rates

1. The following rate elements are applicable to CNC Service:

Network Controller  
Network Access Port  
Graphic Interface  
Digital Cross-connect Terminations  
Service Charges

2. Network Controller

The Network Controller rate includes system partitioning, individual user profiles, initial channel cross-connections, network administration tools, security management, training, and user documentation. Network Access Port charge(s) and Service charge(s) will apply.

3. Network Access Port

Options include dedicated access and/or dial access with a security key. Additional security keys are available as specified in II.E.1.b and II.E.1.c. following. The Network Access Port charge associated with the Network Controller will apply to each signalling channel. This is in addition to applicable Installation Charges and/or Nonrecurring charges specified in this Product Guide and other Tariffs that apply to the dedicated and/or dial-up access. When ordered subsequent to the Service Establishment, a Database Modification Charge will apply.

4. Graphic Interface

May be ordered as an option to the Network Controller. The Graphic Interface option requires a customer provided terminal and presentation software. The rate for this feature is established on a per CNC Service Arrangement basis. When ordered subsequent to the initial CNC Service Arrangement, a Database Modification charge will apply.

<sup>1</sup> Customer Network Control is limited to current customers. No new orders will be accepted for this service prior to December 1, 2008.

Effective: April 1, 2016

---

DIGITAL NETWORK SERVICES

II. CUSTOMER NETWORK CONTROL<sup>1</sup> (Continued)

D. Application of Rates (Continued)

5. Digital Cross-connect Terminations

A Digital Cross-connect Termination charge is required for each Private Line Service (except Digital Channel Services and Digital Data Services/DDS-type services) terminating on a Digital Cross-connect System port, in addition to the charges for service subscribed to in the appropriate Product Guide or other Company Tariffs. Two Digital Cross-connect Termination charges apply when connecting between two central offices where Digital Cross-connect Terminations are provided, one charge at each termination.

6. Service Charges

a. Service Establishment

The Service Establishment charge applies for the establishment of each CNC Service Arrangement. This charge is in addition to applicable installation charges and/or nonrecurring charges as specified in this Product Guide and other Company Tariffs.

b. Database Modifications

A Database Modification charge applies per CNC Service Arrangement for changes, additions, or deletions requiring revisions to the Network Controller software files. Database Modifications include activities such as specifications of customer profile, security parameters, and additions, or deletions, or changes to ports, equipment, digital cross-connect terminations, and service terminations.

Database Modifications may be ordered per CNC Service Arrangement for either single or multiple activities.

c. Telco Reconfiguration

A Telco Reconfiguration charge applies per CNC Service Arrangement for circuit reconfigurations requested of the Company by the customer for modifications to maps, paths, and profile.

A Database Modification charge and Reconfiguration charge may be applicable on the same service order. when a service reconfiguration is requested that is not associated with the ordered database modificationS, both charges will apply.

<sup>1</sup> Customer Network Control is limited to current customers. No new orders will be accepted for this service prior to December 1, 2008.

Effective: April 1, 2016

DIGITAL NETWORK SERVICES

II. CUSTOMER NETWORK CONTROL<sup>1</sup> (Continued)

D. Application of Rates (Continued)

7. Service Charges applicable to the CNC Service Arrangement will apply in addition to applicable Service Charges for the addition of new services or deletion or conversion of existing services in conjunction with a CNC Service Arrangement.
8. CNC Service is available where the Company's Digital Cross-connect Systems are located. Interoffice channel mileage will be applied, if applicable, to transport Private Line Services to a Digital Cross-connect System equipped central office where the Company's Private Line Service Product Guide and/or Tariff requires the service be routed through a Hub wire center for purposes other than customer specified such as bridging or multiplexing (e.g. the Company chooses to so route for testing, maintenance purposes) rates will be applied only to the distance between the customer premises and the Digital Cross-connect System equipped central office or when applicable, between two Digital Cross-connect System equipped central offices.

E. RATES AND CHARGES

	<u>Nonrecurring Charge</u>	<u>Monthly Rate</u>
1. Network Controller		
a. Per Network Controller, Each Customer	\$1500.00	\$200.00
b. Network Access Port, Each		
Dedicated	15.00	120.00
Dial-up, with security key	11.00	100.00
Additional security key	12.00	3.00
c. Graphic Interface, Per CNC Service Arrangement	300.00	
2. Digital Cross-Connect Terminations		
DS1 Termination	44.00	85.00
Channel Termination - Voicegrade <sup>2</sup>	66.00	15.00
3. Service Charges		
a. Service Establishment	480.00	
b. Database Modification, Single Activity Per CNC Service Arrangement	69.00	
c. Database Modification, Multiple Activities Per CNC Service Arrangement	206.00	
d. Telco Reconfiguration Per CNC Service Arrangement	51.00	

<sup>1</sup> Customer Network Control is limited to current customers. No new orders will be accepted for this service prior to December 1, 2008.

<sup>2</sup> This charge does not apply to Digital Data Service/DDS-type service and Digital Channel Services terminations.

Effective: April 1, 2016

---

ADVANCED DATA SERVICES

TABLE OF CONTENTS

	<u>SHEET NO.</u>
A. VIDEO CONNECTION SERVICE- 270 MBPS	
1. General	1
2. Rate Elements	1
3. Term Commitment Plan (TCP)	3
4. Types of Rates and Charges	3
5. Rates and Charges	4
B. ASYNCHRONOUS TRANSFER MODE (ATM) CELL RELAY SERVICE (CRS)	
1. Application	11
2. Definitions	11
3. Terms and Conditions	22
4. Rates and Charges	
C. FRAME RELAY SERVICE (FRS)	
1. Application	34
2. Definitions	34
3. Terms and Conditions	36
4. Rates and Charges	50
D. DEDICATED SONET RING (DSR)	
1. Application	60
2. Definitions	60
3. Terms and Conditions	62
4. Rates and Charges	83
E. DEDICATED WAVE LENGTH RING (DWR)	
1. Application	98
2. Description of Service	98
3. Terms and Conditions	98
4. Service Components	101
5. Application of Rates and Charges	108
6. Optional Features - Network Management	113
7. Rates and Charges	117



Effective: April 1, 2016

---

ADVANCED DATA SERVICES

TABLE OF CONTENTS

	<u>SHEET NO.</u>
F. INTEGRATED OPTICAL SERVICES (IOS)	
1. Application	124
2. Description of Service	124
3. Acronyms and Definitions	125
4. Service Components	127
5. Technical Specifications	132
6. Terms and Conditions	134
7. Application of Rates and Charges	139
8. Rates and Charges	145
G. SPECIALIZED FIA OR ARRANGEMENTS	
1. General	148
2. Rate and Charges	148
H. SPECIAL FACILITIES ROUTING OF FIA	
1. Description	149
2. Rate and Charges	149
I. SPECIAL FEDERAL GOVERNMENT FIA	
1. General	150
2. Emergency Conditions	150
3. Intervals to Provide FIA	150
4. Safeguarding of FIA	151
5. Federal Government Regulations	151
6. FIA Offerings to the Federal Government	151
J. TRANSPARENT LAN SERVICE (TLS)	
1. Definitions	155
2. Service Description	155
3. Conditions	157
4. Application of Rates and Charges	159
5. Rates and Charges	173
K. CUSTOM CONNECT SERVICE	
1. Description	185
2. Rate Elements	186

Effective: April 1, 2016

---

ADVANCED DATA SERVICES

A. VIDEO CONNECTION SERVICE - 270 MBPS

1. GENERAL

Video Connection Service - 270 Mbps service provides for the real time transport, management and control of moving pictures or video frames of information along with associated audio in a digital, uncompressed format, resulting in the highest quality signaling. Video Connection - 270 Mbps offers the uncompressed digital delivery of high-end film, video, and images via fiber optics.

Video Connection Service - 270 Mbps is offered as a switched configuration or a dedicated (non-switched) configuration. The switched configuration may be a point-to-point or multi-point arrangement that terminates on ports of the Company's video switch. The dedicated arrangement is a point-to-point service for the transmission of video without accessing the Company's video switch.

Video Connection Service - 270 Mbps is available under a month-to-month arrangement, term commitment plan of 1, 2, 3 or 5 years, or on a daily basis. The month-to-month offering requires a minimum service period of three months. In addition, with the exception of daily rates, for the switched configuration there are two volume tier levels used in determining applicable rates, 1-4 switched access line connections and 5 or more line connections between the same locations. When ordering additional connections, the customer must advise the Company of the number of existing connections at the location.

Video Connection Service - 270 Mbps is provided via fiber optic or other compatible facilities. Where appropriate facilities are not available, Special Construction charges may apply as set forth in the Product Guide, Section 3, to provide such facilities required to meet the customer's request.

2. RATE ELEMENTS

The rate elements for Video Connection - 270 Mbps are described as follows:

(a) Switched Video Access Line (SVAL)

The Switched Video Access Line (SVAL) provides for the Video Connection - 270 Mbps line connection between the customer designated locations and its serving wire center. The SVAL includes the appropriate video-enabling equipment, circuit equipment, and outside plant facilities to access the customer's serving wire center. The standard SVAL arrangement defines the technical characteristics associated with the type of facilities with which the video service will interconnect and the type of signaling capability, if any. The SVAL includes any video encoding device that may be necessary to provide the service if any is required.

The SVAL is available on a unidirectional or bi-directional basis.

(b) Switched Video Port

The Switched Video Port is the rate element that provides for the connection of an SVAL to the Company's video network switch. The Switched Video Port rate is applied per SVAL on a unidirectional or bi-directional basis as determined by the directionality of the SVAL associated with the port.

(c) Dedicated Video Line (DVL)

The Dedicated Video Line (DVL) provides for non-switched Video Connection - 270 Mbps line connection between the customer dedicated location and its serving wire center for the purpose of point-to-point video transmission without connecting to a Company video switch.

Effective: April 1, 2016

---

ADVANCED DATA SERVICES

A. VIDEO CONNECTION SERVICE - 270 MBPS (Continued)

2. RATE ELEMENTS (Continued)

(d) Video Connection - 270 Mbps Transport

The Video Connection - 270 Mbps Transport rate element provides for the interoffice transmission facilities for service arrangements where the customer designated locations are not served by the same wire center and/or for switched video arrangements for interoffice transmission facilities between the serving wire center of the customer designated location and the video switch. Where a service is provided by more than one Company, transport will be measured to the meet point. Transport rates are applied under two rate elements, a per airline mile rate component and a fixed mileage component for each 20 miles of transport or fraction thereof.

(e) Optional Features - Video Connection - 270 Mbps

(1) Audio

Audio channels are offered as an unbundled optional feature for Video Connection - 270 Mbps, as not all 270 Mbps video service arrangement require audio. Audio is provided in pairs of stereo channels.

(2) Alternate Switching - Manual

Alternate Switching-Manual provides the customer the ability to call the Video Transmission Center (VTC) and request a video technician to establish or switch up a connection to another location. This optional feature applies on a per switching event basis.

(3) Conversion Services

Conversion services are offered to handle compatibility requirement between the end points of a video circuit. There are two conversion options available, Format Conversion and Code Conversion.

a. Format Conversion - provides for analog to digital, digital to analog, composite to component, component to composite, serial digital to composite, serial digital to component, composite to serial digital and component to serial digital conversions, as may be required.

b. Code Conversion - provides Code compatibility between the end points of the video circuit.

Effective: April 1, 2016

---

ADVANCED DATA SERVICES

A. VIDEO CONNECTION SERVICE - 270 MBPS (Continued)

3. TERM COMMITMENT PLAN (TCP)

(a) Termination Liability

One Year TCP - 50% of any remaining portion of the first year's recurring charges.

Two Year TCP - 50% of any remaining portion of the first year's recurring charges. In addition, for any remaining portion of the second year, the customer will be liable for 10% of the total monthly recurring charges in that time period.

Three Year TCP - 50% of any remaining portion of the first year's recurring charges. In addition, for any remaining portion of the second and third years, the customer will be liable for 10% of the total monthly recurring charges in that time period.

Five Year TCP - 50% of any remaining portion of the first year's recurring charges. In addition, for any remaining portion of the second through fifth years, the customer will be liable for 20% of the total monthly recurring charges in that time period.

(b) Termination Without Liability

During a TCP period, should the currently effective rate for a customer's service increase, the customer may, at their option, terminate the TCP arrangement without penalty or liability.

4. TYPES OF RATES AND CHARGES

(a) Nonrecurring Charges - Nonrecurring charges are one-time charges that apply for specific work activity.

(b) Monthly Rates - Monthly rates are recurring charges that apply each month or fraction thereof that service is provided. For billing purposes, each month is considered to have 30 days.

(c) Weekly Rates - Weekly rates are charges that apply to each seven day usage period or fraction thereof that service is provided, as requested by the customer. In no event will these part-time charges for continuous weekly usage, within the billing period, exceed the monthly rate.

(d) Daily Rates - Daily rates are recurring charges that apply to each 24 hour period or fraction thereof that service is provided. When part-time service is provided for ten or more consecutive days it will be treated as a full-time service and monthly rates will apply. In no event will the charges for continuous part-time service exceed the amount that would be charged in the same billing time period for full-time service.

(e) Hourly Rates - Hourly rate are recurring charges that apply to each 60 minute period, or fraction thereof, that service is provided. The billing period commences when the video circuit is available for the customer's use and ceases when the customer's use is discontinued. The maximum charge during any 30 day period will be that amount equal to 100 hours of use. In no event will the charges for continuous hourly usage exceed the daily rate.

ADVANCED DATA SERVICES

A. VIDEO CONNECTION SERVICE - 270 MBPS (Continued)

5. RATES AND CHARGES

(a) Nonrecurring Rates

	<u>Unit</u>	Maximum <u>Nonrecurring Charge</u> <sup>1</sup>	Current
(1) Switched Video Access Line			
<u>Unidirectional</u>			
Volume 1 to 4			
Month-to-Month	per line	\$750.00	\$ 500.00
1 Year Term	per line	375.00	250.00
2 Year Term	per line	375.00	0.00
3 Year Term	per line	375.00	0.00
5 Year Term	per line	375.00	0.00
Volume 5 or More			
Month-to-Month	per line	375.00	250.00
1 Year Term	per line	375.00	0.00
2 Year Term	per line	375.00	0.00
3 Year Term	per line	375.00	0.00
5 Year Term	per line	375.00	0.00
<u>Bi-directional</u>			
Volume 1 to 4			
Month-to-Month	per line	1,125.00	750.00
1 Year Term	per line	750.00	500.00
2 Year Term	per line	750.00	0.00
3 Year Term	per line	750.00	0.00
5 Year Term	per line	750.00	0.00
Volume 5 or More			
Month-to-Month	per line	562.50	375.00
1 Year Term	per line	562.50	0.00
2 Year Term	per line	562.50	0.00
3 Year Term	per line	562.50	0.00
5 Year Term	per line	562.50	0.00

<sup>1</sup> Section 3 Service Charges are not applicable.

ADVANCED DATA SERVICES

A. VIDEO CONNECTION SERVICE - 270 MBPS (Continued)

5. RATES AND CHARGES (Continued)

(a) Nonrecurring Rates (Continued)

	<u>Unit</u>	Maximum <u>Nonrecurring Charge</u> <sup>1</sup>	Current
(2) Switched Video Port			
<u>Unidirectional</u>			
Volume 1 to 4			
Month-to-Month	per port	\$750.00	\$500.00
1 Year Term	per port	375.00	250.00
2 Year Term	per port	375.00	0.00
3 Year Term	per port	375.00	0.00
5 Year Term	per port	375.00	0.00
Volume 5 or More			
Month-to-Month	per port	375.00	250.00
1 Year Term	per port	375.00	0.00
2 Year Term	per port	375.00	0.00
3 Year Term	per port	375.00	0.00
5 Year Term	per port	375.00	0.00
<u>Bi-directional</u>			
Volume 1 to 4			
Month-to-Month	per port	1,125.00	750.00
1 Year Term	per port	750.00	500.00
2 Year Term	per port	750.00	0.00
3 Year Term	per port	750.00	0.00
5 Year Term	per port	750.00	0.00
Volume 5 or More			
Month-to-Month	per port	562.50	375.00
1 Year Term	per port	562.50	0.00
2 Year Term	per port	562.50	0.00
3 Year Term	per port	562.50	0.00
5 Year Term	per port	562.50	0.00

<sup>1</sup> Section 3 Service Charges are not applicable.

ADVANCED DATA SERVICES

A. VIDEO CONNECTION SERVICE - 270 MBPS (Continued)

5. RATES AND CHARGES (Continued)

(a) Nonrecurring Rates (Continued)

	<u>Unit</u>	Maximum <u>Nonrecurring Charge</u> <sup>1</sup>	Current
(3) Dedicated Video Line (DVL)			
<u>Unidirectional</u>			
Month-to-Month	per line	\$1,500.00	\$1,000.00
1 Year Term	per line	750.00	500.00
2 Year Term	per line	750.00	0.00
3 Year Term	per line	750.00	0.00
5 Year Term	per line	750.00	0.00
<u>Bidirectional</u>			
Month-to-Month	per line	2,250.00	1,500.00
1 Year Term	per line	1,500.00	1,000.00
2 Year Term	per line	1,500.00	0.00
3 Year Term	per line	1,500.00	0.00
5 Year Term	per line	1,500.00	0.00
(4) Optional Feature			
Two Stereo Channels		150.00	100.00
(5) <u>Switched Arrangements - Daily</u>			
Switched Video Port			
Unidirectional	per port	1,200.00	800.00
Bidirectional	per port	1,275.00	850.00
Switched Video Access Line			
Unidirectional	per line	1,200.00	800.00
Bidirectional	per line	1,275.00	850.00
(6) <u>Dedicated Arrangements - Daily</u>			
Dedicated Video Line			
Unidirectional	per line	2,400.00	1,600.00
Bidirectional	per line	2,550.00	1,700.00

<sup>1</sup> Section 3 Service Charges are not applicable.

ADVANCED DATA SERVICES

A. VIDEO CONNECTION SERVICE - 270 MBPS (Continued)

5. RATES AND CHARGES (Continued)

(b) Monthly Rates

	<u>Unit</u>	<u>Maximum Monthly Rates</u>	<u>Current Monthly Rate</u>
(1) Switched Video Access Line			
<u>Unidirectional</u>			
Volume 1 to 4			
Month-to-Month	per line	\$547.50	\$365.00
1 Year Term	per line	540.00	360.00
2 Year Term	per line	532.50	355.00
3 Year Term	per line	525.00	350.00
5 Year Term	per line	517.50	345.00
Volume 5 or More			
Month-to-Month	per line	510.00	340.00
1 Year Term	per line	508.00	335.00
2 Year Term	per line	505.00	330.00
3 Year Term	per line	500.00	325.00
5 Year Term	per line	495.00	325.00
<u>Bi-directional</u>			
Volume 1 to 4			
Month-to-Month	per line	1,125.00	750.00
1 Year Term	per line	1,080.00	720.00
2 Year Term	per line	1,050.00	700.00
3 Year Term	per line	1,027.50	685.00
5 Year Term	per line	1,005.00	670.00
<u>Bi-directional</u>			
Volume 5 or More			
Month-to-Month	per line	1,110.00	740.00
1 Year Term	per line	1,065.00	710.00
2 Year Term	per line	1,035.00	690.00
3 Year Term	per line	1,012.50	675.00
5 Year Term	per line	990.00	660.00



ADVANCED DATA SERVICES

A. VIDEO CONNECTION SERVICE - 270 MBPS (Continued)

5. RATES AND CHARGES (Continued)

(b) Monthly Rates

	<u>Unit</u>	<u>Maximum Monthly Rates</u>	<u>Current Monthly Rate</u>
(2) Switched Video Port			
<u>Unidirectional</u>			
Volume 1 to 4			
Month-to-Month	per line	\$577.50	\$385.00
1 Year Term	per line	537.00	358.00
2 Year Term	per line	530.00	338.00
3 Year Term	per line	525.00	328.00
5 Year Term	per line	520.00	323.00
Volume 5 or More			
Month-to-Month	per line	561.00	374.00
1 Year Term	per line	535.00	348.00
2 Year Term	per line	530.00	328.00
3 Year Term	per line	525.00	318.00
5 Year Term	per line	520.00	313.00
<u>Bi-directional</u>			
Volume 1 to 4			
Month-to-Month	per line	766.50	511.00
1 Year Term	per line	705.00	463.00
2 Year Term	per line	700.00	438.00
3 Year Term	per line	695.00	428.00
5 Year Term	per line	690.00	418.00
Volume 5 or More			
Month-to-Month	per line	717.00	478.00
1 Year Term	per line	705.00	458.00
2 Year Term	per line	700.00	433.00
3 Year Term	per line	695.00	423.00
5 Year Term	per line	690.00	413.00

ADVANCED DATA SERVICES

A. VIDEO CONNECTION SERVICE - 270 MBPS (Continued)

5. RATES AND CHARGES (Continued)

(b) Monthly Rates

	<u>Unit</u>	<u>Maximum Monthly Rates</u>	<u>Current Monthly Rate</u>
(3) Dedicated Video Line			
<u>Unidirectional</u>			
Month-to-Month	per line	\$577.50	\$385.00
1 Year Term	per line	562.50	375.00
2 Year Term	per line	547.50	365.00
3 Year Term	per line	532.50	355.00
5 Year Term	per line	530.00	345.00
<u>Bi-directional</u>			
Month-to-Month	per line	1,155.00	770.00
1 Year Term	per line	1,110.00	740.00
2 Year Term	per line	1,080.00	720.00
3 Year Term	per line	1,057.50	705.00
5 Year Term	per line	1,035.00	690.00
(4) Transport			
<u>Per Mile</u>			
Month-to-Month	per line	24.75	16.50
1 Year Term	per line	24.00	16.00
2 Year Term	per line	23.25	15.50
3 Year Term	per line	22.50	15.00
5 Year Term	per line	21.75	14.50
<u>Per Each 20 Mile Increment</u>			
Month-to-Month	per line	72.00	48.00
1 Year Term	per line	69.00	46.00
2 Year Term	per line	68.00	44.00
3 Year Term	per line	67.00	42.00
5 Year Term	per line	66.00	40.00

Effective: April 1, 2016

ADVANCED DATA SERVICES

A. VIDEO CONNECTION SERVICE - 270 MBPS (Continued)

5. RATES AND CHARGES (Continued)

(b) Monthly Rates

	<u>Unit</u>	<u>Maximum Monthly Rates</u>	<u>Current Monthly Rate</u>
(5) Optional Features			
Two Stereo Channels		\$285.00	\$170.00
Alternate Switching Manual, each event		35.00	20.00
Format Conversion		1,971.00	1,314.00

(c) Weekly Rates <sup>1</sup>

Format Conversion		775.00	475.00
-------------------	--	--------	--------

(d) Daily Rates <sup>2</sup>

(1) Switched Arrangements

Switched Video Port			
Unidirectional	per port	247.50	165.00
Bi-directional	per port	328.50	219.00
Switched Video Access Line			
Unidirectional	per line	230.00	145.00
Bi-directional	per line	435.00	290.00

(2) Dedicated Arrangements

Unidirectional	per line	352.50	235.00
Bi-directional	per line	600.00	400.00

(3) Transport

Per Mile per mile		24.75	16.50
Fixed (Per 20 Mile)		72.00	48.00

(4) Optional Features

Two Stereo Channels		22.50	15.00
Format Conversion		300.00	200.00

(e) Hourly Rates <sup>1</sup>

(1) Optional Features

Format Conversion		132.00	88.00
Code Conversion		132.00	88.00

<sup>1</sup> In no event will charges for continuous weekly usage within the billing period, exceed the monthly rate.

<sup>2</sup> When service is provided for ten or more consecutive days, it will be treated as full-time and monthly rates will apply.

Effective: April 1, 2016

---

ADVANCED DATA SERVICES

B. ASYNCHRONOUS TRANSFER MODE (ATM) CELL RELAY SERVICE (CRS)<sup>1</sup>

1. Application

This section contains definitions, charges, terms and conditions applicable to the provision of Asynchronous Transfer Mode (ATM) Cell Relay Service (CRS), a fully competitive Category III service furnished by the Company within the State of California. The Company, on its sole discretion, shall offer ATM CRS in locations where technical capabilities exist and market conditions warrant.

ATM CRS is available in all existing Frontier exchanges as listed in Section 5, Sheets 2 and 3.

The Company concurs in all of the maps filed as part of Southwestern Bell Communications (SBC) Network and Exchange Services Tariff, Schedule No. A5.

2. Definitions

Extended Service Plan (ESP) - The length of time for which a customer agrees to pay for ATM CRS service. One-, two-, three- or five-year ESPs are available to ATM CRS UNI Port With Access Line Connection, UNI Port Only, or UNI IMA Port With Access Line Connection customers.

Hub - A Company designated serving wire center that is equipped to provide service.

Maximum Burst Size - The term "Maximum Burst Size" (MBS) denotes the consecutive number of ATM cells that can enter the ATM CRS network above the Sustained Cell Rate level and below the Peak Cell Rate level.

3. Terms and Conditions

a. Description of Service

Asynchronous Transfer Mode (ATM) Cell Relay Service (CRS) is a telecommunications transport and switching service that provides for high-speed connectivity between customer-designated locations. ATM CRS consists of a User Network Interface (UNI) available in various configurations including Port With Access Line Connection and Port Only Connection, with either incremental or full bandwidth.

The UNI Port With Access Line Connection is a dedicated digital line that provides a link from the customer's premises to one of the Company's ATM CRS hubs. UNIs are also provisioned as an Inverse Multiplexing ATM (IMA) Port With Access Line Connection as defined in B.3.b.(2), and as a Port Only Connection as defined in B.3.b.(3).

ATM CRS is a fast-packet, cell-based technology that can support user applications requiring high-bandwidth, high-performance transport and switching. This connectivity is provided via Permanent Virtual Circuits (PVCs) and/or Switched Virtual Circuits (SVCs) that are implemented over access facilities and switches that are dedicated to high-speed telecommunications services.

<sup>1</sup> Effective February 15, 2013, ATM Cell Relay Service (ATMCRS) is grandfathered and is no longer available to new customers. Existing customers may maintain their service; however, term commitment plans may not be renewed. Moves or changes to subscribers' existing service are permissible, but the term commitment per circuit will not be extended. Upon expiration of the term commitment the service will lapse into a month-to-month service arrangement and will bill at the one-year rate.

---

ADVANCED DATA SERVICES

B. ASYNCHRONOUS TRANSFER MODE (ATM) CELL RELAY SERVICE (CRS)<sup>1</sup> (Continued)

3. Terms and Conditions (Continued)

b. Service Components

The major components of ATM CRS are:

- UNI Port With Access Line Connection
- UNI Inverse Multiplexing ATM (IMA) Port With Access Line Connection
- UNI Port Only Connection
- Permanent Virtual Circuit (PVC)
- Switched Virtual Circuit (SVC)
- Effective Bandwidth

(1) UNI Port With Access Line Connection

UNI Port With Access Line Connections, which are available at the DS1, DS3, OC3c, and OC12c levels, provide dedicated transport between a customer-designated premises and an ATM CRS hub. There are two types of UNIs: Full and Incremental. The Full UNI includes all available bandwidth in one rate, and the Incremental UNI is sold and provisioned with PVC and/or SVC bandwidth increments. The DS1 UNI is not offered in increments.

In order for customer traffic to be carried on the network, each Incremental UNI requires at least one 5 Mbps increment of either PVC or SVC bandwidth. The customer may elect to subscribe to multiple PVCs. This feature is established over the UNI via connection identifiers, which enables the customer to have virtual connections to various locations.

UNIs are provided at nominal data rates of 1.536 Mbps (DS1), 44.21 Mbps (DS3), 149.76 Mbps (OC3c), or 599.04 Mbps (OC12c). OC3c and OC12c are provided as a concatenated signal in STS-3c and STS-12c (Synchronous Transport Signal) formats, respectively. The actual throughput into CRS is less than the line rate for the UNI provided.

The rates and charges for a UNI are differentiated by the capacity of the UNI, the location where the UNI originates (i.e., customer-designated premises) and mileage ranges (expressed as tiers) associated with extending the UNI to the wire center designated as the ATM CRS hub.

The OC3c and OC12c UNI Port With Access Line Connections are provisioned on Protected or Protected Diverse Synchronous Optical Network (SONET) facilities. SONET is a standards-based fiber optic communication network that transports both asynchronous and synchronous digital signals using the Synchronous Transport Signal (STS) format. ATM OC3c and OC12c Protected SONET UNI Port With Access Line Connections are provisioned over SONET as a survivable service with an alternate (not diverse) facility between the central office and the customer premises. ATM OC3c and OC12c Protected Diverse SONET UNI Port With Access Line Connections are provisioned over SONET as a survivable service with an alternate and diverse path between the ATM CRS hub and the customer premises. DS3, OC3c, OC12c and other interfaces, both electrical and optical, are supported and defined to the technical specifications set forth in B.3.c.

<sup>1</sup> Effective February 15, 2013, ATM Cell Relay Service (ATMCRS) is grandfathered and is no longer available to new customers. Existing customers may maintain their service; however, term commitment plans may not be renewed. Moves or changes to subscribers' existing service are permissible, but the term commitment per circuit will not be extended. Upon expiration of the term commitment the service will lapse into a month-to-month service arrangement and will bill at the one-year rate.

---

ADVANCED DATA SERVICES

B. ASYNCHRONOUS TRANSFER MODE (ATM) CELL RELAY SERVICE (CRS)<sup>1</sup> (Continued)

3. Terms and Conditions (Continued)

b. Service Components (Continued)

(2) UNI Inverse Multiplexing ATM (IMA) Port With Access Line Connection

UNI IMA Port With Access Line Connection permits the provisioning of bandwidth greater than DS1 and less than DS3 by binding together multiple DS1 facilities. The inverse multiplexer at each end of the connection aggregates and de-aggregates multiple parallel DS1 leased lines into a single higher speed link. IMA will be offered as Full bandwidth only. Two to six DS1 facilities will be permitted in an IMA group providing nominal aggregated bandwidth from three to nine megabits per second. IMA allows for all class of service parameters up to the combined nominal line rate of the aggregated DS1s and all PVCs and/or SVCs that will fit within the bandwidth. Ordering of DS1s within an IMA group must be done in ascending order. Disconnecting DS1s within an IMA group must be done in a descending order. Customer must purchase a minimum of two IMA DS1s.

Requests to change existing UNI Port With Access Line Connections to UNI IMA Port With Access Line Connections will be treated as a disconnect and new install. Termination liability<sup>2</sup> charges, as set forth in Section 2 of this Product Guide, will apply.

(3) UNI Port Only Connection

UNI Port Only Connections can be established as a User Network Interface (UNI) arrangement. The UNI Port Only Connection provides an ATM Cell Relay Network connection based on the port connection speeds of DS1, DS3, OC3c and OC12c. The ATM port speed will be consistent with the channel speed of the access channel. The actual throughput of customer traffic cannot exceed the bandwidth of the access channel and port speed.

UNI Port Only Connections are available as either Incremental or Full. This refers to the bandwidth that is required to provision PVCs on the port. Incremental ports come with no bandwidth and bandwidth is purchased in increments based on customer bandwidth requirements. Full ports come with all bandwidth included up to the maximum rate of the port. Each port can accommodate multiple PVCs or SVCs depending on the bandwidth purchased. UNI Port Only is available on a one-year, three-year and five-year term.

Customers may access Port Only Connections via Company-provided digital access facilities or via facilities provided by another carrier. When access facilities are provided by the Company, the associated regulations, rates and charges under the appropriate Company Tariff or Product Guide shall apply in addition to the rates, charges, terms and conditions associated with ATM CRS. Company-provided access facilities may also be provisioned on an Individual Case Basis (ICB) where access facilities are not generally available under the applicable or Product Guide. Interconnection charges to connect access line services provided by the Company or another carrier may apply and will be billed separately. Any special construction or nonstandard charges assessed by the carrier supplying the access facilities will be the responsibility of the customer.

<sup>1</sup> Effective February 15, 2013, ATM Cell Relay Service (ATMCRS) is grandfathered and is no longer available to new customers. Existing customers may maintain their service; however, term commitment plans may not be renewed. Moves or changes to subscribers' existing service are permissible, but the term commitment per circuit will not be extended. Upon expiration of the term commitment the service will lapse into a month-to-month service arrangement and will bill at the one-year rate.

<sup>2</sup> Effective February 15, 2013, Termination Liability will not apply to ATM Cell Relay Service (ATMCRS).

---

ADVANCED DATA SERVICES

B. ASYNCHRONOUS TRANSFER MODE (ATM) CELL RELAY SERVICE (CRS)<sup>1</sup> (Continued)

3. Terms and Conditions (Continued)

b. Service Components (Continued)

(4) Permanent Virtual Circuit (PVC)

The PVC defines a virtual connection across a UNI between the customer premises and the Company's ATM CRS hub. Each UNI requires at least one PVC in order for customer traffic to traverse the network. Each ATM cell carries a unique tag which identifies that ATM CRS cell as belonging to a particular PVC. A PVC is a logical channel connecting two or more customer-designated premises with virtual connections through a Company-provided ATM CRS switch(es). The PVCs may be provided on a point-to-point or point-to-multipoint basis. When a PVC is provided as a point-to-point virtual connection, transmission is bi-directional allowing for ATM CRS cells to be transmitted or received over the same PVC. For point-to-multipoint virtual connections, transmission is provided as transmit only. The virtual connection is set up by the Company based on information contained on a service order rather than by dial-up signaling.

PVCs consist of two types: Virtual Channel Connections (VCCs) and Virtual Path Connections (VPCs). A VCC is a type of PVC with independent identity and defined service parameters that are provisioned via service order, and cannot be altered by the customer without additional service order activity. A VPC is a type of PVC with defined service parameters that is provisioned via service order. Customers may provision their own virtual channels within the VPC, provided that the sum of the service parameters of all of the virtual channels does not exceed the aggregate service parameters of the VPC.

(5) Switched Virtual Circuit (SVC)

SVCs are similar in structure to PVCs, but SVCs are provisioned on demand by customer premises equipment that signals the ATM cell relay network to set up and tear down logical connections. The network will respond to these requests by provisioning a virtual connection across the network based on the class of service parameters requested, provided that sufficient network resources are available to establish the connection. Each UNI that is SVC signal enabled will be provided with a SVC International Code Designator (ICD) prefix that will uniquely identify the UNI. Customers must use this Company-assigned prefix when requesting SVC virtual connections across the Company Cell Relay Network. Each Constant Bit Rate (CBR) and Variable Bit Rate (VBR) SVC will be limited to a maximum Peak Cell Rate of 20 Mbps and a maximum Sustained Cell Rate of 20 Mbps.

Closed User Group (CUG) capability is a feature associated with SVCs. A CUG provides the ability to contain SVC calls between certain UNIs. A CUG functionally groups UNIs into logical associations and allows calling privileges to be specified network wide. A CUG provides a network-wide mechanism for access control. CUGs provide a logical grouping of UNIs, creating a SVC community of interest.

<sup>1</sup> Effective February 15, 2013, ATM Cell Relay Service (ATMCRS) is grandfathered and is no longer available to new customers. Existing customers may maintain their service; however, term commitment plans may not be renewed. Moves or changes to subscribers' existing service are permissible, but the term commitment per circuit will not be extended. Upon expiration of the term commitment the service will lapse into a month-to-month service arrangement and will bill at the one-year rate.

Effective: April 1, 2016

---

ADVANCED DATA SERVICES

B. ASYNCHRONOUS TRANSFER MODE (ATM) CELL RELAY SERVICE (CRS)<sup>1</sup> (Continued)

3. Terms and Conditions (Continued)

b. Service Components (Continued)

(6) Effective Bandwidth

Effective bandwidth is the bandwidth reserved for each logical connection (PVC or SVC) that is set up across a UNI. It is based on the Peak Cell Rate (PCR), Sustained Cell Rate (SCR), Maximum Burst Size, and the class of service parameters selected, i.e., CBR, VBRrt (Variable Bit Rate real time), VBRnrt (Variable Bit Rate non-real time), or UBR (Unspecified Bit Rate). The total effective bandwidth of all the logical connections on a UNI cannot exceed the total bandwidth available on the UNI. Effective bandwidth prices do not vary by class of service level selected. However, effective bandwidth is consumed in varying degrees based on the class of service parameters selected. The higher the class of service, the more bandwidth will be reserved. A CBR PVC with the same PCR as a VBR PVC will reserve more effective bandwidth.

c. Technical Specifications

The technical specifications for ATM CRS are delineated in Technical References TR-NWT-001112, GR-1110-CORE, GR-1248-CORE, and SR-3330.

The technical specifications for DS1 and DS3 signals are delineated in TR-INS-000342.

The technical specifications for OC3c and OC12c signals are delineated in GR-253-CORE, Issue 2.

The technical specifications for UNIs are delineated in ATM Forum ATM User Network Interface Specifications V3.0, af-uni-0010.001, and V3.1, af-uni-0010.002. Interface specifications for customer-provided ATM CRS compatible premises equipment or devices must also be in accordance with the specifications defined in these documents.

d. Provision of Service

ATM CRS includes:

- (1) A minimum of one UNI Port With Access Line, or UNI Port Only, or two UNI IMA Port With Access Lines, which has a maximum nominal capacity for either DS1 (1.536Mbps), DS3 (44.21 Mbps), OC3c (149.76Mbps), or OC12c (599.04 Mbps). The OC3c and OC12c UNIs are provisioned over Protected or Protected Diverse SONET. The Protected and Protected Diverse SONET facilities provide a backup facility that automatically switches in the event of a failure on the primary facility.
- (2) Unlimited usage on purchased bandwidth.
- (3) Incremental UNIs must have at least one increment of effective bandwidth (either PVC or SVC) in order for traffic to traverse the network. The DS1, DS3, OC3c, and OC12c Full UNIs are equipped with the full effective bandwidth.

<sup>1</sup> Effective February 15, 2013, ATM Cell Relay Service (ATMCRS) is grandfathered and is no longer available to new customers. Existing customers may maintain their service; however, term commitment plans may not be renewed. Moves or changes to subscribers' existing service are permissible, but the term commitment per circuit will not be extended. Upon expiration of the term commitment the service will lapse into a month-to-month service arrangement and will bill at the one-year rate.



Effective: April 1, 2016

---

ADVANCED DATA SERVICES

B. ASYNCHRONOUS TRANSFER MODE (ATM) CELL RELAY SERVICE (CRS)<sup>1</sup> (Continued)

3. Terms and Conditions (Continued)

d. Provision of Service (Continued)

ATM CRS includes: (Continued)

- (4) Either one or more PVCs. When PVC bandwidth is purchased, one or more PVCs must be selected for customer traffic to traverse the network.
- (5) Two types of PVCs, (i) Virtual Channel Connections (VCCs) and (ii) Virtual Path Connections (VPCs), which support the following Classes of Service:

- Constant Bit Rate (CBR)
- Variable Bit Rate real time (VBRrt)
- Variable Bit Rate non-real time (VBRnrt)
- Unspecified Bit Rate (UBR)

e. Tier Structure for Local Serving Offices

Locations (wire centers) that provide ATM CRS have been designated as ATM hubs. Each local serving office has been placed in a Tier 1, 2 or 3, based on its location relative to the closest ATM hub.

f. Service Functionality

The ATM CRS functionality consists of transporting 53-byte cells of information from the customer location to a Company ATM hub over a UNI. The traffic is routed in the switch to another UNI, or other suitable network connection.

g. Class of Service Parameters

(1) Constant Bit Rate (CBR)

(a) Peak/Sustained Cell Rate:

Customer-specified in increments of 64 Kbps up to the maximum speed of the UNI.

(b) Non-conforming cells:

Discarded

(c) Cell Delay Variation Tolerance (CDVT):

- DS1 = 600 microseconds
- DS3 = 600 microseconds
- OC3c = 600 microseconds
- OC12c = 600 microseconds

<sup>1</sup> Effective February 15, 2013, ATM Cell Relay Service (ATMCRS) is grandfathered and is no longer available to new customers. Existing customers may maintain their service; however, term commitment plans may not be renewed. Moves or changes to subscribers' existing service are permissible, but the term commitment per circuit will not be extended. Upon expiration of the term commitment the service will lapse into a month-to-month service arrangement and will bill at the one-year rate.

Effective: April 1, 2016

---

ADVANCED DATA SERVICES

B. ASYNCHRONOUS TRANSFER MODE (ATM) CELL RELAY SERVICE (CRS)<sup>1</sup> (Continued)

3. Terms and Conditions (Continued)

g. Class of Service Parameters (Continued)

(2) Variable Bit Rate (VBR) Real Time/Non-Real Time

(a) Sustained Cell Rate (SCR):

Customer specified in increments of 64 Kbps up to the maximum speed of the UNI.

(b) Peak Cell Rate (PCR):

Customer selectable in increments of 64 Kbps up to line rate. Default is 200% of SCR for PVCs. (The ratio of PCR to SCR will be signaled by Customer Premises Equipment [CPE] for SVCs. Therefore there is no default value.)

(c) Non-conforming cells:

Discarded

(d) Cell Delay Variation Tolerance (CDVT):

DS1 = 600 microseconds  
DS3 = 600 microseconds  
OC3c = 600 microseconds  
OC12c = 600 microseconds

h. Special Conditions

(1) ATM CRS is available where facilities and conditions permit. For locations where the customer requests ATM CRS and digital, or SONET facilities are not available, special construction charges may apply.

(2) Maintenance Window

To meet the customers' requirements, occasional network upgrades must be performed. These network upgrades are needed to provide improved performance and new features. Generally, these upgrades will be performed between the hours of 11 PM and 8 AM. Network upgrades are planned to provide customers reasonable and timely notification in order to minimize any impact on the customers' service.

<sup>1</sup> Effective February 15, 2013, ATM Cell Relay Service (ATMCRS) is grandfathered and is no longer available to new customers. Existing customers may maintain their service; however, term commitment plans may not be renewed. Moves or changes to subscribers' existing service are permissible, but the term commitment per circuit will not be extended. Upon expiration of the term commitment the service will lapse into a month-to-month service arrangement and will bill at the one-year rate.

Effective: April 1, 2016

---

ADVANCED DATA SERVICES

B. ASYNCHRONOUS TRANSFER MODE (ATM) CELL RELAY SERVICE (CRS)<sup>1</sup> (Continued)

3. Terms and Conditions (Continued)

i. Responsibility of the Customer

The customer must provide the necessary compatible premises equipment or ATM CRS device capable of interfacing with the Company's ATM CRS.

j. Responsibility of the Company

The Company is responsible for service up to and including the network interface. The Company's responsibility is limited to the furnishing of communications facilities and switches suitable for ATM CRS.

ATM CRS is supported by the Company's Single Point of Contact (SPOC) center, which provides continuous support for ATM CRS 24 hours per day, seven days per week (24x7) with the ability to manage all of the customer's ATM CRS as a single network. The SPOC performs maintenance, trouble resolution and network management functions on a 24x7 basis. Service order processing and network installation functions are performed only during normal business hours.

k. Application of Rates and Charges

(1) Rate Elements

The following rate elements are applicable to ATM CRS:

- UNI Port With Access Line Connection
- UNI Inverse Multiplexing ATM (IMA) Port With Access Line Connection
- UNI Port Only Connection
- Permanent Virtual Circuits (PVCs)
- Effective Bandwidth for Incremental UNIs
- Closed User Groups (CUG)
- Administrative Charge

<sup>1</sup> Effective February 15, 2013, ATM Cell Relay Service (ATMCRS) is grandfathered and is no longer available to new customers. Existing customers may maintain their service; however, term commitment plans may not be renewed. Moves or changes to subscribers' existing service are permissible, but the term commitment per circuit will not be extended. Upon expiration of the term commitment the service will lapse into a month-to-month service arrangement and will bill at the one-year rate.

Effective: April 1, 2016

---

ADVANCED DATA SERVICES

B. ASYNCHRONOUS TRANSFER MODE (ATM) CELL RELAY SERVICE (CRS)<sup>1</sup> (Continued)

3. Terms and Conditions (Continued)

k. Application of Rates and Charges (Continued)

(1) Rate Elements (Continued)

(a) UNI Port With Access Line Connection

A monthly rate applies on a per Port With Access Line basis, based on the speed (i.e., DS1, DS3, OC3c or OC12c) and/or type (i.e., Full or Incremental, SONET - Protected or Protected Diverse) of the access connection. UNI Port and Access is offered as a one year, two year, three year or five year Extended Service Plan (ESP) only. Nonrecurring charges from this Product Guide or any other tariff of the Company do not apply.

(b) UNI Inverse Multiplexing ATM (IMA) Port With Access Line Connection

A monthly rate applies on a per DS1 basis for each sequential DS1 ordered up to the desired bandwidth (i.e., 3 Mbps, 4.5 Mbps, 6 Mbps, 7.5 Mbps, or 9 Mbps). IMA is offered as a one year, two year, three year or five year Extended Service Plan (ESP). DS1s within an IMA group added subsequent to the initial installation of the first two DS1s will have their own term period. Nonrecurring charges from this Product Guide or any other tariff of the Company do not apply.

(c) UNI Port Only Connection

A monthly rate applies on a per Port Only basis, based on the speed (i.e., DS1, DS3, OC3c or OC12c) and/or type (i.e., Full or Incremental) of the port only connection. UNI Port Only is offered as a one year, two year, three year or five year Extended Service Plan (ESP) only. Nonrecurring charges from this Product Guide or any other tariff of the Company do not apply.

(d) Permanent Virtual Circuits (PVCs)

A nonrecurring charge applies per order for Virtual Channel Connection (VCC) or Virtual Path Connection (VPC). PVCs are ordered per UNI. If multiple UNIs are involved, a nonrecurring charge will apply to each UNI Port on which the virtual connections will reside. The nonrecurring charge does not apply when PVCs are installed at the same time as the respective UNIs.

<sup>1</sup> Effective February 15, 2013, ATM Cell Relay Service (ATMCRS) is grandfathered and is no longer available to new customers. Existing customers may maintain their service; however, term commitment plans may not be renewed. Moves or changes to subscribers' existing service are permissible, but the term commitment per circuit will not be extended. Upon expiration of the term commitment the service will lapse into a month-to-month service arrangement and will bill at the one-year rate.

Effective: April 1, 2016

---

ADVANCED DATA SERVICES

B. ASYNCHRONOUS TRANSFER MODE (ATM) CELL RELAY SERVICE (CRS)<sup>1</sup> (Continued)

3. Terms and Conditions (Continued)

k. Application of Rates and Charges (Continued)

(1) Rate Elements (Continued)

(e) Effective Bandwidth for Incremental UNIs

A monthly rate applies for incremental UNIs for CBR or VBR PVC and SVC bandwidth at 5 Mbps for DS3 or OC3c and at 15 Mbps for OC12c. A monthly rate also applies for incremental UNIs for UBR PVC and SVC bandwidth for DS3, OC3c and OC12c. Nonrecurring charges from this Product Guide or any other tariff of the Company do not apply.

The monthly rate for PVC and/or SVC UBR bandwidth will be waived when the combined VBR and CBR effective bandwidth purchased (either SVC or PVC or any combination) is equal to at least 50% of the effective bandwidth capacity of the UNI. When UBR bandwidth is made available, it is available for both PVCs and SVCs. Nonrecurring charges from this Product Guide or any other tariff of the Company do not apply.

(f) Closed User Groups (CUG)

A nonrecurring charge applies per order and per UNI for each CUG established and for each subsequent CUG member added to a CUG. The nonrecurring charge does not apply when a CUG is installed at the same time as the respective UNI.

(g) Administrative Charge

A nonrecurring charge applies (per order, per UNI) when the customer initiates a change to one or more of the following: UNI bandwidth, PVCs, class of service parameters, and/or other service parameters that do not require changes in physical facilities and that can be provisioned by the Company without the dispatch of a technician to the customer location. For each service order issued, the charge will be one Administrative Charge regardless of the number of changes made. The Administrative Charge does not apply for those items ordered on the same service order with the installation of a UNI.

<sup>1</sup> Effective February 15, 2013, ATM Cell Relay Service (ATMCRS) is grandfathered and is no longer available to new customers. Existing customers may maintain their service; however, term commitment plans may not be renewed. Moves or changes to subscribers' existing service are permissible, but the term commitment per circuit will not be extended. Upon expiration of the term commitment the service will lapse into a month-to-month service arrangement and will bill at the one-year rate.

Effective: April 1, 2016

---

ADVANCED DATA SERVICES

B. ASYNCHRONOUS TRANSFER MODE (ATM) CELL RELAY SERVICE (CRS)<sup>1</sup> (Continued)

3. Terms and Conditions (Continued)

k. Application of Rates and Charges (Continued)

(2) Minimum Charge

The minimum charge for ATM CRS will not be less than one Monthly Recurring Charge (MRC) for the applicable service and term selected, plus Termination Liability<sup>2</sup> as described in B.3.k.(3)(a) below.

(3) Extended Service Plan

The ATM CRS UNI Port With Access Line Connection, UNI IMA Port With Access Line Connection and UNI Port Only Connection rate elements are available under an ESP.

Term commitments of one-, two-, three- and five-years are available to ATM CRS UNI Port With Access Line Connection, UNI Port Only, or UNI IMA Port With Access Line Connection customers at the applicable rates set forth in B.4 following, regardless of when they subscribe to an ESP arrangement.

(a) Termination Liability<sup>2</sup>

If ATM CRS is terminated by the customer prior to the anniversary date of the initial term commitment period, termination liability charges, as set forth in Section 2 of this Product Guide, will apply.

(4) Moves

When the customer requests a move or relocation of the UNI, the move or relocation will be treated as a termination of the existing service and the establishment of a new service.

(5) Special Facilities Routing

The customer may request that the facilities used to provide ATM CRS be specially routed. Additional charges will apply based on cost.

(6) Acceptance Testing

At the customer's request, the Company will cooperatively test at the time of installation at no additional charge. Acceptance tests will include tests for the parameters applicable to the service as specified in the order for service.

<sup>1</sup> Effective February 15, 2013, ATM Cell Relay Service (ATMCRS) is grandfathered and is no longer available to new customers. Existing customers may maintain their service; however, term commitment plans may not be renewed. Moves or changes to subscribers' existing service are permissible, but the term commitment per circuit will not be extended. Upon expiration of the term commitment the service will lapse into a month-to-month service arrangement and will bill at the one-year rate.

<sup>2</sup> Effective February 15, 2013, Termination Liability will not apply to ATM Cell Relay Service (ATMCRS).

Effective: April 1, 2016

---

ADVANCED DATA SERVICES

B. ASYNCHRONOUS TRANSFER MODE (ATM) CELL RELAY SERVICE (CRS)<sup>1</sup> (Continued)

4. Rates and Charges

a. UNI Port with Access Line Connection

	<u>Monthly Rate</u>
(1) DS1, each	
Full	
Tier 1 (0 to 5 Miles)	
One Year	\$805.00
Two Year	765.00
Three Year	684.00
Five Year	644.00
Tier 2 (Over 5 to 25 Miles)	
One Year	805.00
Two Year	765.00
Three Year	684.00
Five Year	644.00
Tier 3 (Over 25 to 50 Miles)	
One Year	805.00
Two Year	765.00
Three Year	684.00
Five Year	644.00

<sup>1</sup> Effective February 15, 2013, ATM Cell Relay Service (ATMCRS) is grandfathered and is no longer available to new customers. Existing customers may maintain their service; however, term commitment plans may not be renewed. Moves or changes to subscribers' existing service are permissible, but the term commitment per circuit will not be extended. Upon expiration of the term commitment the service will lapse into a month-to-month service arrangement and will bill at the one-year rate.

Effective: April 1, 2016

---

ADVANCED DATA SERVICES

B. ASYNCHRONOUS TRANSFER MODE (ATM) CELL RELAY SERVICE (CRS)<sup>1</sup> (Continued)

4. Rates and Charges (Continued)

a. UNI Port with Access Line Connection (Continued)

	<u>Monthly Rate</u>
(2) DS3, each	
Full	
Tier 1 (0 to 5 Miles)	
One Year	\$4,060.00
Two Year	3,857.00
Three Year	3,451.00
Five Year	3,247.00
Tier 2 (Over 5 to 25 Miles)	
One Year	4,776.00
Two Year	4,538.00
Three Year	4,060.00
Five Year	3,821.00
Tier 3 (Over 25 to 50 Miles)	
One Year	5,731.00
Two Year	5,444.00
Three Year	4,872.00
Five Year	4,585.00
Incremental	
Tier 1 (0 to 5 Miles)	
One Year	3,407.00
Two Year	3,235.00
Three Year	2,895.00
Five Year	2,725.00
Tier 2 (Over 5 to 25 Miles)	
One Year	4,007.00
Two Year	3,807.00
Three Year	3,407.00
Five Year	3,205.00
Tier 3 (Over 25 to 50 Miles)	
One Year	4,808.00
Two Year	4,568.00
Three Year	4,088.00
Five Year	3,847.00

<sup>1</sup> Effective February 15, 2013, ATM Cell Relay Service (ATMCRS) is grandfathered and is no longer available to new customers. Existing customers may maintain their service; however, term commitment plans may not be renewed. Moves or changes to subscribers' existing service are permissible, but the term commitment per circuit will not be extended. Upon expiration of the term commitment the service will lapse into a month-to-month service arrangement and will bill at the one-year rate.



Effective: April 1, 2016

---

ADVANCED DATA SERVICES

B. ASYNCHRONOUS TRANSFER MODE (ATM) CELL RELAY SERVICE (CRS)<sup>1</sup> (Continued)

4. Rates and Charges (Continued)

a. UNI Port with Access Line Connection (Continued)

	<u>Monthly Rate</u>
(3) OC3c, each (Continued)	
<u>SONET</u>	
Full, Protected	
Tier 1 (0 to 5 Miles)	
One Year	\$7,659.00
Two Year	7,277.00
Three Year	6,511.00
Five Year	6,127.00
Tier 2 (Over 5 to 25 Miles)	
One Year	9,011.00
Two Year	8,561.00
Three Year	7,659.00
Five Year	7,209.00
Tier 3 (Over 25 to 50 Miles)	
One Year	10,813.00
Two Year	10,272.00
Three Year	9,192.00
Five Year	8,650.00
Full, Protected Diverse	
Tier 1 (0 to 5 Miles)	
One Year	9,353.00
Two Year	8,886.00
Three Year	7,951.00
Five Year	7,482.00
Tier 2 (Over 5 to 25 Miles)	
One Year	11,003.00
Two Year	10,453.00
Three Year	9,353.00
Five Year	8,803.00
Tier 3 (Over 25 to 50 Miles)	
One Year	13,204.00
Two Year	12,544.00
Three Year	11,224.00
Five Year	10,563.00

<sup>1</sup> Effective February 15, 2013, ATM Cell Relay Service (ATMCRS) is grandfathered and is no longer available to new customers. Existing customers may maintain their service; however, term commitment plans may not be renewed. Moves or changes to subscribers' existing service are permissible, but the term commitment per circuit will not be extended. Upon expiration of the term commitment the service will lapse into a month-to-month service arrangement and will bill at the one-year rate.

ADVANCED DATA SERVICES

B. ASYNCHRONOUS TRANSFER MODE (ATM) CELL RELAY SERVICE (CRS)<sup>1</sup> (Continued)

4. Rates and Charges (Continued)

a. UNI Port with Access Line Connection (Continued)

	<u>Monthly Rate</u>
(3) OC3c, each (Continued)	
<u>SONET</u> (Continued)	
Incremental, Protected	
Tier 1 (0 to 5 Miles)	
One Year	\$5,336.00
Two Year	5,070.00
Three Year	4,536.00
Five Year	4,269.00
Tier 2 (Over 5 to 25 Miles)	
One Year	6,278.00
Two Year	5,964.00
Three Year	5,336.00
Five Year	5,023.00
Tier 3 (Over 25 to 50 Miles)	
One Year	7,534.00
Two Year	7,158.00
Three Year	6,403.00
Five Year	6,027.00
Incremental, Protected Diverse	
Tier 1 (0 to 5 Miles)	
One Year	7,030.00
Two Year	6,679.00
Three Year	5,976.00
Five Year	5,624.00
Tier 2 (Over 5 to 25 Miles)	
One Year	8,271.00
Two Year	7,856.00
Three Year	7,030.00
Five Year	6,617.00
Tier 3 (Over 25 to 50 Miles)	
One Year	9,924.00
Two Year	9,428.00
Three Year	8,436.00
Five Year	7,940.00

<sup>1</sup> Effective February 15, 2013, ATM Cell Relay Service (ATMCRS) is grandfathered and is no longer available to new customers. Existing customers may maintain their service; however, term commitment plans may not be renewed. Moves or changes to subscribers' existing service are permissible, but the term commitment per circuit will not be extended. Upon expiration of the term commitment the service will lapse into a month-to-month service arrangement and will bill at the one-year rate.

Effective: April 1, 2016

---

ADVANCED DATA SERVICES

B. ASYNCHRONOUS TRANSFER MODE (ATM) CELL RELAY SERVICE (CRS)<sup>1</sup> (Continued)

4. Rates and Charges (Continued)

a. UNI Port with Access Line Connection (Continued)

	<u>Monthly Rate</u>
(4) OC12c, each	
<u>SONET</u>	
Full, Protected	
Tier 1 (0 to 5 Miles)	
One Year	\$ 23,668.00
Two Year	22,484.00
Three Year	20,118.00
Five Year	18,934.00
Tier 2 (Over 5 to 25 Miles)	
One Year	27,844.00
Two Year	26,452.00
Three Year	23,668.00
Five Year	22,275.00
Tier 3 (Over 25 to 50 Miles)	
One Year	33,413.00
Two Year	31,742.00
Three Year	28,401.00
Five Year	26,730.00
Full, Protected Diverse	
Tier 1 (0 to 5 Miles)	
One Year	\$ 25,604.00
Two Year	24,323.00
Three Year	21,764.00
Five Year	20,483.00
Tier 2 (Over 5 to 25 Miles)	
One Year	30,121.00
Two Year	28,615.00
Three Year	25,604.00
Five Year	24,098.00
Tier 3 (Over 25 to 50 Miles)	
One Year	36,146.00
Two Year	34,339.00
Three Year	30,724.00
Five Year	28,917.00

<sup>1</sup> Effective February 15, 2013, ATM Cell Relay Service (ATMCRS) is grandfathered and is no longer available to new customers. Existing customers may maintain their service; however, term commitment plans may not be renewed. Moves or changes to subscribers' existing service are permissible, but the term commitment per circuit will not be extended. Upon expiration of the term commitment the service will lapse into a month-to-month service arrangement and will bill at the one-year rate.

Effective: April 1, 2016

---

ADVANCED DATA SERVICES

B. ASYNCHRONOUS TRANSFER MODE (ATM) CELL RELAY SERVICE (CRS)<sup>1</sup> (Continued)

4. Rates and Charges (Continued)

a. UNI Port with Access Line Connection (Continued)

	<u>Monthly Rate</u>
(4) OC12c, each (Continued)	
<u>SONET</u> (Continued)	
Incremental, Protected	
Tier 1 (0 to 5 Miles)	
One Year	\$15,730.00
Two Year	14,944.00
Three Year	13,371.00
Five Year	12,584.00
Tier 2 (Over 5 to 25 Miles)	
One Year	18,505.00
Two Year	17,580.00
Three Year	15,730.00
Five Year	14,805.00
Tier 3 (Over 25 to 50 Miles)	
One Year	22,207.00
Two Year	21,097.00
Three Year	18,876.00
Five Year	17,765.00
Incremental, Protected Diverse	
Tier 1 (0 to 5 Miles)	
One Year	17,666.00
Two Year	16,783.00
Three Year	15,016.00
Five Year	14,133.00
Tier 2 (Over 5 to 25 Miles)	
One Year	20,783.00
Two Year	19,744.00
Three Year	17,666.00
Five Year	16,627.00
Tier 3 (Over 25 to 50 Miles)	
One Year	24,940.00
Two Year	23,693.00
Three Year	21,199.00
Five Year	19,952.00

<sup>1</sup> Effective February 15, 2013, ATM Cell Relay Service (ATMCRS) is grandfathered and is no longer available to new customers. Existing customers may maintain their service; however, term commitment plans may not be renewed. Moves or changes to subscribers' existing service are permissible, but the term commitment per circuit will not be extended. Upon expiration of the term commitment the service will lapse into a month-to-month service arrangement and will bill at the one-year rate.

Effective: April 1, 2016

---

ADVANCED DATA SERVICES

B. ASYNCHRONOUS TRANSFER MODE (ATM) CELL RELAY SERVICE (CRS)<sup>1</sup> (Continued)

4. Rates and Charges (Continued)

b. UNI Inverse Multiplexing ATM (IMA)

	<u>Monthly Rate</u>
(1) First DS1, each (1.5 Mbps total bandwidth)	
Full	
Tier 1 (0 to 5 Miles)	
One Year	\$828.00
Two Year	788.00
Three Year	704.00
Five Year	663.00
Tier 2 (Over 5 to 25 Miles)	
One Year	828.00
Two Year	788.00
Three Year	704.00
Five Year	663.00
Tier 3 (Over 25 to 50 Miles)	
One Year	828.00
Two Year	788.00
Three Year	704.00
Five Year	663.00
(2) Second DS1, each (3 Mbps total bandwidth)	
Full	
Tier 1 (0 to 5 Miles)	
One Year	787.00
Two Year	747.00
Three Year	684.00
Five Year	644.00
Tier 2 (Over 5 to 25 Miles)	
One Year	787.00
Two Year	747.00
Three Year	684.00
Five Year	644.00
Tier 3 (Over 25 to 50 Miles)	
One Year	787.00
Two Year	747.00
Three Year	684.00
Five Year	644.00

<sup>1</sup> Effective February 15, 2013, ATM Cell Relay Service (ATMCRS) is grandfathered and is no longer available to new customers. Existing customers may maintain their service; however, term commitment plans may not be renewed. Moves or changes to subscribers' existing service are permissible, but the term commitment per circuit will not be extended. Upon expiration of the term commitment the service will lapse into a month-to-month service arrangement and will bill at the one-year rate.

Effective: April 1, 2016

---

ADVANCED DATA SERVICES

B. ASYNCHRONOUS TRANSFER MODE (ATM) CELL RELAY SERVICE (CRS)<sup>1</sup> (Continued)

4. Rates and Charges (Continued)

b. UNI Inverse Multiplexing ATM (IMA) (Continued)

	<u>Monthly Rate</u>
(3) Third DS1, each (4.5 Mbps total bandwidth)	
Full	
Tier 1 (0 to 5 Miles)	
One Year	\$ 757.00
Two Year	718.00
Three Year	642.00
Five Year	605.00
Tier 2 (Over 5 to 25 Miles)	
One Year	757.00
Two Year	718.00
Three Year	642.00
Five Year	605.00
Tier 3 (Over 25 to 50 Miles)	
One Year	757.00
Two Year	718.00
Three Year	642.00
Five Year	605.00
(4) Fourth DS1, each (6 Mbps total bandwidth)	
Full	
Tier 1 (0 to 5 Miles)	
One Year	\$ 757.00
Two Year	718.00
Three Year	642.00
Five Year	605.00
Tier 2 (Over 5 to 25 Miles)	
One Year	757.00
Two Year	718.00
Three Year	642.00
Five Year	605.00
Tier 3 (Over 25 to 50 Miles)	
One Year	757.00
Two Year	718.00
Three Year	642.00
Five Year	605.00

<sup>1</sup> Effective February 15, 2013, ATM Cell Relay Service (ATMCRS) is grandfathered and is no longer available to new customers. Existing customers may maintain their service; however, term commitment plans may not be renewed. Moves or changes to subscribers' existing service are permissible, but the term commitment per circuit will not be extended. Upon expiration of the term commitment the service will lapse into a month-to-month service arrangement and will bill at the one-year rate.

Effective: April 1, 2016

---

ADVANCED DATA SERVICES

B. ASYNCHRONOUS TRANSFER MODE (ATM) CELL RELAY SERVICE (CRS)<sup>1</sup> (Continued)

4. Rates and Charges (Continued)

b. UNI Inverse Multiplexing ATM (IMA) (Continued)

	<u>Monthly Rate</u>
(5) Fifth DS1, each (7.5 Mbps total bandwidth) Full	
Tier 1 (0 to 5 Miles)	
One Year	\$ 757.00
Two Year	718.00
Three Year	642.00
Five Year	605.00
Tier 2 (Over 5 to 25 Miles)	
One Year	757.00
Two Year	718.00
Three Year	642.00
Five Year	605.00
Tier 3 (Over 25 to 50 Miles)	
One Year	757.00
Two Year	718.00
Three Year	642.00
Five Year	605.00
(6) Sixth DS1, each (9 Mbps total bandwidth) Full	
Tier 1 (0 to 5 Miles)	
One Year	\$ 757.00
Two Year	718.00
Three Year	642.00
Five Year	605.00
Tier 2 (Over 5 to 25 Miles)	
One Year	757.00
Two Year	718.00
Three Year	642.00
Five Year	605.00
Tier 3 (Over 25 to 50 Miles)	
One Year	757.00
Two Year	718.00
Three Year	642.00
Five Year	605.00

<sup>1</sup> Effective February 15, 2013, ATM Cell Relay Service (ATMCRS) is grandfathered and is no longer available to new customers. Existing customers may maintain their service; however, term commitment plans may not be renewed. Moves or changes to subscribers' existing service are permissible, but the term commitment per circuit will not be extended. Upon expiration of the term commitment the service will lapse into a month-to-month service arrangement and will bill at the one-year rate.

Effective: April 1, 2016

---

ADVANCED DATA SERVICES

B. ASYNCHRONOUS TRANSFER MODE (ATM) CELL RELAY SERVICE (CRS)<sup>1</sup> (Continued)

4. Rates and Charges (Continued)

c. UNI Port Only Connection

	<u>Monthly Rate</u>
(1) DS1, each	
Full	
One Year	\$420.00
Two Year	399.00
Three Year	358.00
Five Year	337.00
(2) DS3, each	
Full	
One Year	1,481.00
Two Year	1,407.00
Three Year	1,258.00
Five Year	1,185.00
Incremental	
One Year	712.00
Two Year	677.00
Three Year	605.00
Five Year	570.00
(3) OC3c, each	
Full	
One Year	3,872.00
Two Year	3,678.00
Three Year	3,291.00
Five Year	3,098.00
Incremental	
One Year	1,139.00
Two Year	1,081.00
Three Year	968.00
Five Year	911.00

<sup>1</sup> Effective February 15, 2013, ATM Cell Relay Service (ATMCRS) is grandfathered and is no longer available to new customers. Existing customers may maintain their service; however, term commitment plans may not be renewed. Moves or changes to subscribers' existing service are permissible, but the term commitment per circuit will not be extended. Upon expiration of the term commitment the service will lapse into a month-to-month service arrangement and will bill at the one-year rate.



ADVANCED DATA SERVICES

B. ASYNCHRONOUS TRANSFER MODE (ATM) CELL RELAY SERVICE (CRS)<sup>2</sup> (Continued)

4. Rates and Charges (Continued)

c. UNI Port Only Connection (Continued)

	<u>Monthly Rate</u>
(4) OC12c, each	
Full	
One Year	\$13,609.00
Two Year	12,929.00
Three Year	11,568.00
Five Year	10,888.00
Incremental	
One Year	4,270.00
Two Year	4,057.00
Three Year	3,630.00
Five Year	3,417.00

d. Permanent Virtual Circuits (PVCs), per order

	<u>Nonrecurring Charge</u> <sup>1</sup>
(1) Virtual Channel Connections (VCCs)	
Constant Bit rate (CBR)	\$75.00
Variable Bit Rate real time (VBRrt)	75.00
Variable Bit Rate non-real time (VBRnrt)	75.00
Unspecified Bit Rate (UBR)	75.00
(2) Virtual Path Connections (VPCs)	
Constant Bit Rate (CBR)	75.00
Variable Bit Rate real time (VBRrt)	75.00
Variable Bit Rate non-real time (VBRnrt)	75.00
Unspecified Bit Rate (UBR)	75.00

<sup>1</sup> Applies per order and in lieu of service charges found elsewhere in this section or in Section 3, Service Charges. If multiple UNIs are involved, a nonrecurring charge will apply to each UNI Port on which the virtual connections will reside. The nonrecurring charge does not apply when PVCs are installed at the same time as the respective UNIs.

<sup>2</sup> Effective February 15, 2013, ATM Cell Relay Service (ATMCRS) is grandfathered and is no longer available to new customers. Existing customers may maintain their service; however, term commitment plans may not be renewed. Moves or changes to subscribers' existing service are permissible, but the term commitment per circuit will not be extended. Upon expiration of the term commitment the service will lapse into a month-to-month service arrangement and will bill at the one-year rate.

Effective: April 1, 2016

ADVANCED DATA SERVICES

B. ASYNCHRONOUS TRANSFER MODE (ATM) CELL RELAY SERVICE (CRS)<sup>2</sup> (Continued)

4. Rates and Charges (Continued)

e. Effective Bandwidth for Incremental UNIs

	<u>Nonrecurring Charge</u>	<u>Monthly Rate</u>
(1) CBR or VBR PVC Bandwidth		
DS3 or OC3c - 5 Mbps	--	\$ 97.00
OC12c - 15 Mbps	--	242.00
(2) CBR or VBR SVC Bandwidth		
DS3 or OC3c – 5 Mbps	--	97.00
OC12c – 15 Mbps	--	242.00
(3) UBR PVC and SVC Bandwidth, Bandwidth up to the UNI line rate		
DS3	--	484.00
OC3c	--	1,452.00
OC12c	--	4,840.00
f. Closed User Groups (CUG) <sup>1</sup> , per order, per UNI		
(1) Each CUG	\$75.00	--
(2) Each subsequent CUG member added to a CUG	75.00	--
g. Administrative Charge <sup>1</sup> , per order, per UNI	75.00	--

<sup>1</sup> Applies per order, per UNI, and in lieu of service charges found elsewhere in this section or in Section 3, Service Charges. The nonrecurring charge does not apply for those items ordered on the same service order with the installation of a UNI.

<sup>2</sup> Effective February 15, 2013, ATM Cell Relay Service (ATMCRS) is grandfathered and is no longer available to new customers. Existing customers may maintain their service; however, term commitment plans may not be renewed. Moves or changes to subscribers' existing service are permissible, but the term commitment per circuit will not be extended. Upon expiration of the term commitment the service will lapse into a month-to-month service arrangement and will bill at the one-year rate.

Effective: April 1, 2016

---

ADVANCED DATA SERVICES

C. FRAME RELAY SERVICE (FRS)<sup>1</sup>

1. APPLICATION

This section contains definitions, charges, terms and conditions applicable to the provision of Frame Relay Service (FRS), a fully competitive Category III service furnished by the Company within the State of California. The Company, on its sole discretion, shall offer FRS in locations where technical capabilities exist and market conditions warrant.

FRS is available in all existing Frontier exchanges as listed in Section 5, Sheets 2 and 3.

The Company concurs in all of the maps filed as part of Southwestern Bell Communications (SBC) Network and Exchange Services tariff, Schedule No. A5.

2. DEFINITIONS

In addition to the General Definitions set forth in Section 1, the following definitions apply:

Committed Information Rate (CIR) - The maximum information rate at which customer traffic will be admitted to the network without being designated eligible for discard.

Customer Designated Location (CDL) - The geographic location designated by the customer at which an access component of the customer's service is first considered to enter the Company's network.

Data Link Connection Identifier (DLCI) - The Frame Relay virtual circuit number corresponding to a particular destination which is part of the frame relay header and is usually ten bits long.

Excess Burst Size B(e) - The data rate above the Committed Information Rate (CIR), but less than the port size, at which customer data will be admitted to the Frame Relay network. All Excess Burst data B(e) admitted to the network will be designated as eligible for discard.

Frame - A group of data bits, in a specific format, with a flag at either end to indicate the beginning and end of the frame. The defined format enables network equipment to recognize the meaning and purpose of specific bits.

Frame Relay Service - A connection oriented fast packet network service that permits the transmission of data at speeds of 56 Kbps to 44.736 Mbps using Permanent Virtual Connections (PVCs).

Local Area Network (LAN) - A network permitting the interconnection of multiple computers, typically within a single building or campus.

Logical Channel - A communications channel that allows two-way simultaneous transmission of data packets through the network. Capacity is made available as the data is transmitted. Each permanent virtual circuit is one logical channel.

<sup>1</sup> Effective February 15, 2013, Frame Relay Service is grandfathered and is no longer available to new customers. Existing customers may maintain their service; however, term commitment plans may not be renewed. Moves or changes to subscribers' existing service are permissible, but the term commitment per circuit will not be extended. Upon expiration of the term commitment the service will lapse into a month-to-month service arrangement

Effective: April 1, 2016

---

ADVANCED DATA SERVICES

C. FRAME RELAY SERVICE (FRS)<sup>1</sup> (Continued)

2. DEFINITIONS (Continued)

Maximum Burst Rate (MBR) - The maximum information rate at which customer traffic will be admitted to the network. Traffic rates in excess of MBR will automatically be discarded on ingress to the network. The Maximum Burst Rate is equal to the sum of the Committed Information Rate (CIR) and Excess Burst Size B(e).

Network-to-Network Interface (NNI) – A standard interface used to connect two frame relay services, and includes elements such as bi-directional polling to assist the network services providers in gaining information on the status of the networks being connected.

Permanent Virtual Circuit (PVC) - A logical channel, defined in software that establishes a path from one customer port to another.

Port - The entry point on the switch to which the customer is connected. Ports are available which allow connection to the Frame Relay network at speeds of 56 Kbps to 44.736 Mbps.

Statistical Multiplexing - A multiplexing technique in which time slots are dynamically allocated on the basis of need rather than being predetermined. The data is typically transmitted on a first come, first served basis.

Term Payment Plan (TPP) - The length of time for which a customer agrees to pay for Frame Relay Service. Payment periods of one year, three years and five years are available for the UNI Port and Access Line, UNI Port Only and Private NNI Port Only rate elements. PVC CIR and PVC CIR Optional Features are not offered under a TPP.

User-to-Network Interface (UNI) - A standard interface used to connect the end user to the Frame Relay Service network. It receives the data frame from the customer's Local Area Network (LAN) or other customer-provided equipment (CPE) devices and verifies that the Data Link Connection Identifier (DLCI) is valid before relaying the frame to the destination end point. The DLCI is a Frame Relay term defining a 10-bit field of the address field, and it identifies data links and their service parameters.

<sup>1</sup> Effective February 15, 2013, Frame Relay Service is grandfathered and is no longer available to new customers. Existing customers may maintain their service; however, term commitment plans may not be renewed. Moves or changes to subscribers' existing service are permissible, but the term commitment per circuit will not be extended. Upon expiration of the term commitment the service will lapse into a month-to-month service arrangement.

Effective: April 1, 2016

---

ADVANCED DATA SERVICES

C. FRAME RELAY SERVICE (FRS)<sup>1</sup> (Continued)

3. TERMS AND CONDITIONS

The rates, terms and conditions specified herein are in addition to the applicable rates, terms and conditions specified in other sections of this Product Guide and other Tariffs of the Company.

a. Description of Service

- (1) Frame Relay Service (FRS) is a data communications service that provides for data connectivity between/among widely distributed locations. This connectivity is provided via Permanent Virtual Circuit (PVC) connections implemented over access facilities utilizing a switch dedicated to high-speed data services.
- (2) FRS is a transport service that facilitates the exchange of variable length information units (frames) between end user connections by way of PVCs. Each frame is passed to the Frame Relay network with an address that specifies the permanent virtual circuit.
- (3) Variable frame length capability is useful in communications between asynchronous Local Area Networks (LAN) and for transport of synchronous data traffic. FRS is capable of handling the requirements of bursty data sources because of the ability of the service to allocate additional bandwidth when not in use by other sources.
- (4) In operation of FRS, Customer Premises Equipment (CPE), such as routers, encapsulate arriving data into variable length frames. These frames contain information identifying which PVC in the network should be used to forward the frame to the proper destination. The CPE then sends the frame into the Frame Relay network. The Frame Relay switch reads identifying information and routes the frame to the proper destination based on a pre-established PVC path.
- (5) The statistical multiplexing Frame Relay switches are able to provide shared network resources to end users of this service.
- (6) The Committed Information Rate (CIR) and Excess Burst Size B(e) are traffic management parameters that allow the customer to fine tune implementation of FRS.
- (7) FRS, as provided for in this Section, is offered for intrastate use only.

<sup>1</sup> Effective February 15, 2013, Frame Relay Service is grandfathered and is no longer available to new customers. Existing customers may maintain their service; however, term commitment plans may not be renewed. Moves or changes to subscribers' existing service are permissible, but the term commitment per circuit will not be extended. Upon expiration of the term commitment the service will lapse into a month-to-month service arrangement.

Effective: April 1, 2016

---

ADVANCED DATA SERVICES

C. FRAME RELAY SERVICE (FRS)<sup>1</sup> (Continued)

3. TERMS AND CONDITIONS (Continued)

b. Service Components

The major components of FRS are:

User-to-Network Interface (UNI) Port and Access Line  
Port Only

- UNI Port Only
- Private Network-to-Network (NNI) Port Only

Permanent Virtual Circuit (PVC) Committed Information Rate (CIR)  
PVC CIR Optional Features

- Backup UNI

(1) User-to-Network Interface (UNI) Port and Access Line

The UNI Port and Access Line forms the component which provides the customer access to the customer's serving wire center and interoffice transport from the customer's serving wire center to the Frame Relay switch. The UNI Port and Access Line is provided for use only with FRS and where facilities and conditions permit.

(2) Port Only

Customers may access Port Only connections via Company-provided digital access facilities or via facilities provided by another carrier. The channel speed of the access channel must be sufficient to accommodate the Frame Relay port speed. When access facilities are provided by the Company, the associated regulations, rates and charges under the appropriate Company Tariff or Product Guide shall apply in addition to the regulations, rates and charges associated with FRS. Company-provided access facilities may also be provisioned on an Individual Case Basis (ICB) where access facilities are not generally available under the applicable Tariff or Product Guide. Interconnection charges to connect access line services provided by the Company or another carrier may apply and will be billed separately. Any special construction or nonstandard charges assessed by the carrier supplying the access facilities will be the responsibility of the customer.

<sup>1</sup> Effective February 15, 2013, Frame Relay Service is grandfathered and is no longer available to new customers. Existing customers may maintain their service; however, term commitment plans may not be renewed. Moves or changes to subscribers' existing service are permissible, but the term commitment per circuit will not be extended. Upon expiration of the term commitment the service will lapse into a month-to-month service arrangement.

Effective: April 1, 2016

---

ADVANCED DATA SERVICES

C. FRAME RELAY SERVICE (FRS)<sup>1</sup> (Continued)

3. TERMS AND CONDITIONS (Continued)

b. Service Components (Continued)

(2) Port Only (Continued)

(a) UNI Port Only

The UNI Port Only provides for a user to carrier connection (i.e., end user customer to the Company).

(b) Private Network-to-Network (NNI) Port Only

The Private NNI port configuration is used for connecting two networks together for bi-directional messaging and is available on a private basis only. A Private NNI is a NNI port sold for the exclusive use of the customer.

(3) Permanent Virtual Circuit (PVC) Committed Information Rate (CIR)

(a) Permanent Virtual Circuits (PVCs) are logical circuits that define a specific path for data sent by the customer to another location. These circuits are virtual because they are established in software tables and do not tie up capacity when not in use. This also allows multiple paths (PVCs) to be defined on any given port, thereby providing a single access line the capability to transmit data to multiple destinations.

(b) Since multiple PVCs may be defined on one physical port, it is possible for the cumulative Committed Information Rates (CIRs) to exceed the physical bandwidth of that port. This is referred to as over-subscription and when this occurs, the aggregate CIR defined for that port and PVC will not be available at any point in time.

(c) The following types of PVC CIR are available:

- Intrazone - An Intrazone PVC is a logical channel path between two customer Frame Relay ports within the same zone. Frame Relay zones are found in j.(1)(f). following.
- Multi-jurisdictional – A Multi-jurisdictional PVC is a logical channel path between two customer Frame Relay ports, one being an interstate port and the other an intrastate port both located within the same Frame Relay zone. A Multi-jurisdictional PVC falls under federal jurisdiction and the PVC CIR rates, rules and regulations from the appropriate Company Tariff or Product Guide are applicable.
- Public NNI – A Public NNI PVC is a logical channel path between a customer Frame Relay port and a Public NNI port, both located within the same Frame Relay zone. A Public NNI Port is a Frame Relay Port provided to serve multiple users and is owned and controlled by the Company.

<sup>1</sup> Effective February 15, 2013, Frame Relay Service is grandfathered and is no longer available to new customers. Existing customers may maintain their service; however, term commitment plans may not be renewed. Moves or changes to subscribers' existing service are permissible, but the term commitment per circuit will not be extended. Upon expiration of the term commitment the service will lapse into a month-to-month service arrangement.

Effective: April 1, 2016

---

ADVANCED DATA SERVICES

C. FRAME RELAY SERVICE (FRS)<sup>1</sup> (Continued)

3. TERMS AND CONDITIONS (Continued)

b. Service Components (Continued)

(4) PVC CIR Optional Features

- (a) Interzone Transport – Interzone transport provides the mapping of a Frame Relay Intrazone PVC across one or more Frame Relay zone boundaries. Interzone Transport is available only with Intrazone PVC CIR at the rates set forth in 4.e.(1) following.
- (b) Frame Relay to ATM Service Interworking - Frame Relay to ATM Service Interworking provides for the conversion of Frame Relay packets to ATM cells and the conversion of ATM cells to Frame Relay Packets. Frame Relay to ATM Service Interworking is available with Intrazone and Multi-jurisdictional PVC CIR at no additional charge.

(5) Backup UNI

Backup UNI service is a disaster avoidance and disaster recovery feature that consists of a Primary UNI and a Backup UNI, and incorporates PVC remapping capabilities of the Frame Relay network. The Primary UNI is terminated at the primary customer host location and in normal operation serves PVCs between the primary host location and various customer remote locations. A second UNI, which is designated by the customer as a Backup UNI, is installed and terminated at the customer's backup host location. During normal operations no PVCs are mapped to the Backup UNI. The customer will be required to purchase both UNIs. In the event of a Primary UNI, primary digital access line or, customer primary host location failure, the predefined PVC configuration can be remapped to the Backup UNI at the customer's request. Upon restoral of the Primary UNI service the customer must contact the Company to initiate remapping of PVCs from the Backup UNI back to the Primary UNI. A Backup UNI, which may serve as a backup to one or more Primary UNIs, can only backup one Primary UNI at a time. A Backup UNI must be the same port speed or greater than the Primary UNI(s).

<sup>1</sup> Effective February 15, 2013, Frame Relay Service is grandfathered and is no longer available to new customers. Existing customers may maintain their service; however, term commitment plans may not be renewed. Moves or changes to subscribers' existing service are permissible, but the term commitment per circuit will not be extended. Upon expiration of the term commitment the service will lapse into a month-to-month service arrangement.



---

ADVANCED DATA SERVICES

C. FRAME RELAY SERVICE (FRS)<sup>1</sup> (Continued)

3. TERMS AND CONDITIONS (Continued)

c. Technical Specifications

FRS conforms to the transmission specification standards in the following references:

ANSI T1.602 Integrated Services Digital Network (ISDN) – Data Link Layer Signaling Specification for Application at the User-Network Interface – Issued 1989

ANSI T1.606 Frame Relay Bearer Service, Architectural Framework and Service Description – Issued 1990

ANSI T1.617 Integrated Services Digital Network (ISDN) – Digital Subscriber Signaling Specification for Frame Relay Bearer Service – Issued 1991.

ANSI T1.618 Integrated Services Digital Network (ISDN) – Core Aspects of Frame Relay Bearer Service – Issued 1991

d. Provision of Service

- (1) FRS is provided to the customer in the form of the UNI Port and Access Line, UNI Port Only, Private NNI Port Only and CIR based PVCs. The UNI Port and Access Line forms the local access component to the customer's serving central office. The UNI Port Only and Private NNI Port Only include the electronic equipment necessary to interface the access line to the Frame Relay switch.
- (2) PVCs are provisioned on a specified speed and CIR basis, depending upon the customer's request. The actual throughput of aggregated PVC bandwidths in use at the same time on the same port cannot exceed the port speed.
- (3) The maximum CIR allowed is determined by the lower of the two port speeds connected by the PVC. The maximum CIR allowed for port speeds at 1.536 Mbps and below is 75% of the lower of the two port speeds. For port speeds above 1.536 Mbps to 44.736 Mbps, the maximum CIR allowed is 50% of the lower of the two port speeds.
- (4) The PVC must be associated with at least one Frame Relay port. A Frame Relay port can be associated with multiple PVCs.

<sup>1</sup> Effective February 15, 2013, Frame Relay Service is grandfathered and is no longer available to new customers. Existing customers may maintain their service; however, term commitment plans may not be renewed. Moves or changes to subscribers' existing service are permissible, but the term commitment per circuit will not be extended. Upon expiration of the term commitment the service will lapse into a month-to-month service arrangement.

Effective: April 1, 2016

---

ADVANCED DATA SERVICES

C. FRAME RELAY SERVICE (FRS)<sup>1</sup> (Continued)

3. TERMS AND CONDITIONS (Continued)

d. Provision of Service (Continued)

- (5) The customer subscribing to a Port Only or Port and Access Line will be referred to as the controller of the Frame Relay port. A separate entity may, with written authorization from the controller, subscribe to a PVC that allows communication between entities. A disconnect of a PVC does not result in the disconnect of the underlying access line and port. Only the controller may order the disconnect of the FRS.
- (6) The Frame Relay port with PVC CIR capacity may be ordered and billed separately from an associated Frame Relay port and PVC, and can have different customers as controllers.
- (7) 4 Mbps, 6 Mbps, 10 Mbps and 22 Mbps speeds are provisioned utilizing 44.736 Mbps of transport bandwidth; no other service(s) may utilize the remaining bandwidth.
- (8) FRS is available where facilities and conditions permit.

e. Special Conditions

(1) Maintenance Window

- (a) Occasionally, in order to perform software updates and other maintenance, it may be necessary to take the Frame Relay switch out of service, during the predetermined maintenance window of 11:00p.m. to 8:00 a.m. In these cases, all attempts will be made to notify the customer in advance as to the time and duration of these outages. The Company reserves the right to temporarily interrupt the FRS at other times in emergency situations.

f. Obligations of the Customer

- (1) Where FRS is available for use in connection with communications systems or equipment provided by a customer or user, the operating characteristics of such systems or equipment shall be such as not to interfere with any services offered by the Company. Such use is subject to the further provisions that the equipment provided by the customer or user does not endanger the safety of the Company's employees or the public; damage, harm, require change in or alteration of the equipment or other services of the Company; interfere with the proper operation of the Company's equipment or otherwise injure the public in its use of the Company's services. Upon notice from the Company that the equipment provided by the customer or user is causing, or is likely to cause, such hazard or interference, the customer shall take such steps as shall be necessary to remove or prevent such hazard or interference.
- (2) The customer, upon request, shall furnish such information as may be required to permit the Company to design and maintain the FRS it offers and to assure that the service arrangement is in compliance with the terms and conditions contained herein.

<sup>1</sup> Effective February 15, 2013, Frame Relay Service is grandfathered and is no longer available to new customers. Existing customers may maintain their service; however, term commitment plans may not be renewed. Moves or changes to subscribers' existing service are permissible, but the term commitment per circuit will not be extended. Upon expiration of the term commitment the service will lapse into a month-to-month service arrangement.

---

ADVANCED DATA SERVICES

C. FRAME RELAY SERVICE (FRS)<sup>1</sup> (Continued)

3. TERMS AND CONDITIONS (Continued)

f. Obligations of the Customer (Continued)

- (3) It shall be the responsibility of the customer to ensure the continuing compatibility of the customer-provided equipment that is used in conjunction with the FRS. The CPE shall be in compliance with the terms and conditions specified in this section.
- (4) The customer shall be responsible for obtaining permission for the Company's agents or employees to enter the premises of the customer at any reasonable hour for the purpose of installing, inspecting, repairing, or, upon termination of the service, removing the service components of the Company.
- (5) At service subscription, the customer must specify the CIR and is expected to provide the DLCI and the B(e) for each PVC ordered.
- (6) Error correction is the responsibility of the customer's terminal equipment and/or applications. If the FRS network experiences congestion or failures, customer data may be discarded. In addition, frames that are received in excess of the Maximum Burst Rate (MBR), with bad addresses, or other errors will be discarded on ingress to the network. The customer's Frame Relay terminal equipment has the responsibility for retransmitting frames that are discarded due to errors or network congestion.
- (7) The customer is responsible for provisioning the inside wire from the network interface to the Frame Relay compatible equipment.
- (8) A customer ordering Backup UNI service is responsible for the following:
  - Determining network configuration before and after the activation of Backup UNI service.
  - Providing the Company with the appropriate information required for joint development of the Backup UNI database.
  - Maintaining its own port configurations and router tables (for seamless changes from the Primary UNI to the Backup UNI, the customer must use the same addressing scheme on routers connected to the primary and backup sites).
  - Contacting the Company to request all activations and deactivations of Backup UNI service.

<sup>1</sup> Effective February 15, 2013, Frame Relay Service is grandfathered and is no longer available to new customers. Existing customers may maintain their service; however, term commitment plans may not be renewed. Moves or changes to subscribers' existing service are permissible, but the term commitment per circuit will not be extended. Upon expiration of the term commitment the service will lapse into a month-to-month service arrangement.

Effective: April 1, 2016

---

ADVANCED DATA SERVICES

C. FRAME RELAY SERVICE (FRS)<sup>1</sup> (Continued)

3. TERMS AND CONDITIONS (Continued)

g. Obligations of the Company

- (1) The responsibility of the Company shall be limited to furnishing network equipment suitable for FRS and to the maintenance and operation of such equipment in a manner proper for such service. Subject to this responsibility, the Company shall not be responsible for the through transmission of signals generated by the customer-provided equipment or system, or for the quality of, or defects in, such transmission or the reception of signals by such equipment or systems.
- (2) The Company shall not be responsible for installation, operation or maintenance of any terminal equipment, data unit or communications system provided by a customer or user. The Company is not responsible for adapting FRS to the technological requirements of any specific customer equipment.
- (3) When a customer orders FRS which is relayed to Frame Relay networks of other carriers, the Company will provide advisory assistance as a part of the establishment of this service.
- (4) Local Frame Relay circuits impacted by the transition of assets to Frontier effective July 1, 2010 will be provided as currently configured through September 2011. These existing Local Frame Relay circuits receive service from Frontier switches and terminate within Frontier territory. Due to operational constraints, as of July 1, 2010 (the Frontier Sales Transaction Closing Date), MAC activity (Moves, Adds or Changes) will no longer be provided.

Changes to the Local Frame Relay service circuits or continuation of service after September 2011 will be addressed by Frontier, the service provider for the impacted circuits, following the Transaction Closing Date.

- (5) The Company shall not be responsible to the customer or user if changes in any of the equipment, operations or procedures of the Company used in the provision of FRS render any facilities provided by the customer or user obsolete or require modification or alteration of such equipment or system or otherwise affect its use or performance, provided the Company has met any applicable information disclosure requirements otherwise required by law.
- (6) The Company undertakes the responsibility to maintain and repair the service that it furnishes. Network equipment installed by the Company on the customer's premises shall be and remain the property of the Company. The customer or user may not rearrange, disconnect, remove, attempt to repair, remote test, or interface with any network equipment installed by the Company without prior written consent by the Company.
- (7) The Company has the service responsibility up to and including the network interface.

<sup>1</sup> Effective February 15, 2013, Frame Relay Service is grandfathered and is no longer available to new customers. Existing customers may maintain their service; however, term commitment plans may not be renewed. Moves or changes to subscribers' existing service are permissible, but the term commitment per circuit will not be extended. Upon expiration of the term commitment the service will lapse into a month-to-month service arrangement.

Effective: April 1, 2016

---

ADVANCED DATA SERVICES

C. FRAME RELAY SERVICE (FRS)<sup>1</sup> (Continued)

3. TERMS AND CONDITIONS (Continued)

h. Special Facilities Routing

The customer may request that the facilities used to provide FRS be specially routed. Additional charges will apply based on cost.

i. Acceptance Testing

At the customer's request, the Company will cooperatively test at the time of installation at no additional charge. Acceptance tests will include tests for the parameters applicable to the service as specified in the order for service.

j. Application of Rates

(1) Rate Elements

The following rate elements are applicable to FRS:

UNI Port and Access Line  
Port Only  
- UNI Port Only  
- Private NNI Port Only  
PVC CIR  
PVC CIR Optional Features  
Subsequent PVC CIR Charge  
Backup UNI  
Software Change Charge

(a) UNI Port and Access Line

A monthly recurring charge based on the speed of the port connection applies per port for each physical connection to the network supporting FRS. In addition, a nonrecurring charge applies to the month-to-month plan. Nonrecurring charges do not apply to UNI Port and Access Line offered on a Term Payment Plan (TPP). UNI Port and Access Line is offered on a month-to-month basis or as a TPP of one year, three years, or five years.

<sup>1</sup> Effective February 15, 2013, Frame Relay Service is grandfathered and is no longer available to new customers. Existing customers may maintain their service; however, term commitment plans may not be renewed. Moves or changes to subscribers' existing service are permissible, but the term commitment per circuit will not be extended. Upon expiration of the term commitment the service will lapse into a month-to-month service arrangement.

Effective: April 1, 2016

---

ADVANCED DATA SERVICES

C. FRAME RELAY SERVICE (FRS)<sup>1</sup> (Continued)

3. TERMS AND CONDITIONS (Continued)

j. Application of Rates (Continued)

(1) Rate Elements (Continued)

(b) Port Only – UNI Port Only and Private NNI Port Only

A monthly recurring charge based on the speed of the port connection applies per port for each Port Only interface. In addition, a nonrecurring charge applies to the month-to-month plan. Nonrecurring charges do not apply to Port Only offered on a TPP. Port Only is offered on a month-to-month basis or as a TPP of one year, three years, or five years.

Refer to 3.b.(2) preceding for the terms and conditions associated with Port Only digital access facilities.

(c) Permanent Virtual Circuit (PVC) Committed Information Rate (CIR)

- Intrazone - A monthly recurring charge, based on CIR capacity, applies for each PVC requested by the customer. Frame Relay zones are found in (f) following.
- Multi-jurisdictional - A Multi-jurisdictional PVC falls under federal jurisdiction and the PVC CIR rates, rules and regulations from the Frontier Operating Companies Tariff FCC No. 8 are applicable.
- Public NNI – A monthly recurring charge, based on CIR capacity, applies for each PVC requested by the customer.

(d) PVC CIR Optional Features

- Interzone Transport – A monthly recurring charge, based on CIR capacity, applies for each application of Interzone Transport and is in addition to the applicable charges for Intrazone PVC CIR. Interzone Transport is available only with Intrazone PVC CIR.
- Frame Relay to ATM Service Interworking - Frame Relay to ATM Service Interworking is available with Intrazone and Multi-jurisdictional PVC CIR at no additional charge.

(e) Subsequent PVC CIR Charge – A nonrecurring charge applies when a customer orders additional PVC CIR subsequent to the initial port installation.

<sup>1</sup> Effective February 15, 2013, Frame Relay Service is grandfathered and is no longer available to new customers. Existing customers may maintain their service; however, term commitment plans may not be renewed. Moves or changes to subscribers' existing service are permissible, but the term commitment per circuit will not be extended. Upon expiration of the term commitment the service will lapse into a month-to-month service arrangement.

Effective: April 1, 2016

---

ADVANCED DATA SERVICES

C. FRAME RELAY SERVICE (FRS)<sup>2</sup> (Continued)

3. TERMS AND CONDITIONS (Continued)

j. Application of Rates (Continued)

(1) Rate Elements (Continued)

(f) Frame Relay Zones

<u>Zone</u>	<u>Office</u>
Los Angeles	Covina Lancaster Long Beach Ontario Oxnard Perris Redondo Beach San Bernardino Santa Monica Sepulveda Thousand Oaks Victorville Whittier
Manteca <sup>1</sup>	Manteca
Novato <sup>1</sup>	Los Gatos Novato
Palm Springs	Palm Springs
Santa Barbara/Santa Maria	Santa Barbara Santa Maria
Taft <sup>1</sup>	Taft

(g) Backup UNI

A nonrecurring charge applies when a customer requests an activation of the Backup UNI service. No additional charges are applied upon deactivation of Backup UNI service.

(h) Software Change Charge

A nonrecurring charge applies per order when a customer requests a PVC parameter change (i.e., CIR, burst, DLCI re-map to a different host or remote). For each service order issued per UNI or Private NNI, the charge will be one Software Change Charge regardless of the number of changes made.

<sup>1</sup> Interzone transport optional feature not available.

<sup>2</sup> Effective February 15, 2013, Frame Relay Service is grandfathered and is no longer available to new customers. Existing customers may maintain their service; however, term commitment plans may not be renewed. Moves or changes to subscribers' existing service are permissible, but the term commitment per circuit will not be extended. Upon expiration of the term commitment the service will lapse into a month-to-month service arrangement.

Effective: April 1, 2016

---

ADVANCED DATA SERVICES

C. FRAME RELAY SERVICE (FRS)<sup>1</sup> (Continued)

3. TERMS AND CONDITIONS (Continued)

j. Application of Rates (Continued)

(2) Service Charges

Unless otherwise stated in this Section, nonrecurring charges applicable to FRS are in lieu of service charges found elsewhere in this Product Guide or other Company Tariffs.

(3) Minimum Period

The minimum period for FRS is one month except when the customer subscribes to a TPP. When PVCs are added to existing FRS, the minimum period for the PVC is one month.

(4) Term Payment Plan (TPP)

(a) The UNI Port and Access Line, UNI Port Only and Private NNI Port Only rate elements are available under a TPP. PVC CIR and PVC CIR Optional Features are not offered under a TPP.

(b) Payment periods of one year, three years and five years are available to all customers at the applicable rates set forth in Rates and Charges C.4. following, regardless of when they subscribe to a TPP arrangement.

(c) Changes to a TPP period

Prior to the completion of the selected TPP period, the customer may elect to convert to a new TPP period of the same or different length, subject to the following conditions:

- No credit toward the new payment period will be given for payments made under the original TPP arrangement.
- Nonrecurring charges will not be reapplied for existing service(s).
- If the value of the new TPP is less than the remaining value of current TPP, the change to the new TPP period constitutes a disconnect of the existing TPP service and termination liability<sup>2</sup> charges, as set forth in Section 2.B.15 of this Product Guide, will apply.

Conversion to a different TPP or to a month-to-month option will require the customer to submit an order. If no other changes are requested, no nonrecurring charges will apply.

<sup>1</sup> Effective February 15, 2013, Frame Relay Service is grandfathered and is no longer available to new customers. Existing customers may maintain their service; however, term commitment plans may not be renewed. Moves or changes to subscribers' existing service are permissible, but the term commitment per circuit will not be extended. Upon expiration of the term commitment the service will lapse into a month-to-month service arrangement.



Effective: April 1, 2016

---

ADVANCED DATA SERVICES

C. FRAME RELAY SERVICE (FRS)<sup>1</sup> (Continued)

3. TERMS AND CONDITIONS (Continued)

j. Application of Rates (Continued)

(4) Term Payment Plan (TPP) (Continued)

(d) Termination Liability<sup>2</sup>

In the event FRS is terminated by the customer prior to completion of the initial term commitment period, Termination Liability Charges as set forth in Section 2 of this Product Guide, will apply.

(5) Service Rearrangements

(a) Additions to Service

- With the exception of PVCs, when service elements are added to an existing service, the added elements must meet the minimum period requirements associated with the service to which they are added. When PVCs are added to an existing FRS, the minimum period for the added PVCs is one month.
- Nonrecurring charges will apply for all additions to existing services or optional features for which nonrecurring charges normally apply at installation.
- Related monthly rates and nonrecurring charges for addition(s) to service are the rate and charges in effect at the time of the addition(s).

(b) Administrative Changes

Administrative changes to existing service will be made without charge(s) to the customer. Administrative changes may include but are not limited to the following:

- Change of customer name, i.e., the customer or record does not change but rather the customer of record changes its name, e.g., XYZ Company to XYZ Communications,
- Change of customer premises address when the change of address is not a result of a physical relocation of facilities,
- Change in billing data (name, address, or contact name or telephone number), and
- Change of customer contact name or telephone number.

<sup>1</sup> Effective February 15, 2013, Frame Relay Service is grandfathered and is no longer available to new customers. Existing customers may maintain their service; however, term commitment plans may not be renewed. Moves or changes to subscribers' existing service are permissible, but the term commitment per circuit will not be extended. Upon expiration of the term commitment the service will lapse into a month-to-month service arrangement.

<sup>2</sup> Effective February 15, 2013, Termination Liability will not apply to Frame Relay Service.

Effective: April 1, 2016

---

ADVANCED DATA SERVICES

C. FRAME RELAY SERVICE (FRS)<sup>1</sup> (Continued)

3. TERMS AND CONDITIONS (Continued)

j. Application of Rates (Continued)

(5) Service Rearrangements (Continued)

(c) Conversion of service to another jurisdiction will be treated as a disconnect of service and establishment of new service. However, if no other changes are ordered, nonrecurring charges will apply.

(d) Moves

When the customer requests a move or relocation of the UNI Port and Access Line, UNI Port Only or Private NNI Port Only, the move or relocation will be treated as a termination of the existing service and the establishment of a new service.

(e) Upgrade to Higher Speed Service

The customer may elect to upgrade service(s) to a higher speed during a TPP period without incurring termination liability<sup>2</sup>, subject to the following conditions:

- Both the existing and the new service are provided solely by the Company.
- The order to discontinue service at an existing speed or capacity and the order for the upgraded service are received by the Company at the same time.
- The new service will provided at the same customer location as the discontinued service.

<sup>1</sup> Effective February 15, 2013, Frame Relay Service is grandfathered and is no longer available to new customers. Existing customers may maintain their service; however, term commitment plans may not be renewed. Moves or changes to subscribers' existing service are permissible, but the term commitment per circuit will not be extended. Upon expiration of the term commitment the service will lapse into a month-to-month service arrangement.

Effective: April 1, 2016

ADVANCED DATA SERVICES

C. FRAME RELAY SERVICE (FRS)<sup>2</sup> (Continued)

4. RATES AND CHARGES

a. UNI Port and Access Line, each

	Nonrecurring Charge <sup>1</sup>	Monthly Rate
56 Kbps		
Month-to-Month	\$595.00	\$206.00
One Year	0.00	200.00
Three Years	0.00	188.00
Five Years	0.00	169.00
128 Kbps		
Month-to-Month	595.00	387.00
One Year	0.00	375.00
Three Years	0.00	351.00
Five Years	0.00	321.00
256 Kbps		
Month-to-Month	595.00	496.00
One Year	0.00	484.00
Three Years	0.00	454.00
Five Years	0.00	424.00
384 Kbps		
Month-to-Month	695.00	503.00
One Year	0.00	484.00
Three Years	0.00	454.00
Five Years	0.00	424.00
1.536 Mbps		
Month-to-Month	695.00	714.00
One Year	0.00	678.00
Three Years	0.00	636.00
Five Years	0.00	581.00

<sup>1</sup> Applies in lieu of service charges found elsewhere in this Product Guide or other Company Tariffs.

<sup>2</sup> Effective February 15, 2013, Frame Relay Service is grandfathered and is no longer available to new customers. Existing customers may maintain their service; however, term commitment plans may not be renewed. Moves or changes to subscribers' existing service are permissible, but the term commitment per circuit will not be extended. Upon expiration of the term commitment the service will lapse into a month-to-month service arrangement.

Effective: April 1, 2016

ADVANCED DATA SERVICES

C. FRAME RELAY SERVICE (FRS)<sup>2</sup> (Continued)

4. RATES AND CHARGES (Continued)

a. UNI Port and Access Line, each (Continued)

	<u>Nonrecurring Charge</u> <sup>1</sup>	<u>Monthly Rate</u>
4 Mbps		
Month-to-Month	\$795.00	\$3,872.00
One Year	0.00	3,751.00
Three Years	0.00	3,630.00
Five Years	0.00	3,509.00
6 Mbps		
Month-to-Month	795.00	3,993.00
One Year	0.00	3,872.00
Three Years	0.00	3,751.00
Five Years	0.00	3,630.00
10 Mbps		
Month-to-Month	795.00	4,235.00
One Year	0.00	4,114.00
Three Years	0.00	3,993.00
Five Years	0.00	3,751.00
22 Mbps		
Month-to-Month	795.00	4,598.00
One Year	0.00	4,356.00
Three Years	0.00	4,114.00
Five Years	0.00	3,872.00
44.736 Mbps		
Month-to-Month	795.00	5,082.00
One Year	0.00	4,719.00
Three Years	0.00	4,356.00
Five Years	0.00	3,993.00

<sup>1</sup> Applies in lieu of service charges found elsewhere in this Product Guide or other Company Tariffs.

<sup>2</sup> Effective February 15, 2013, Frame Relay Service is grandfathered and is no longer available to new customers. Existing customers may maintain their service; however, term commitment plans may not be renewed. Moves or changes to subscribers' existing service are permissible, but the term commitment per circuit will not be extended. Upon expiration of the term commitment the service will lapse into a month-to-month service arrangement.

Effective: April 1, 2016

---

ADVANCED DATA SERVICES

C. FRAME RELAY SERVICE (FRS)<sup>3</sup> (Continued)

4. RATES AND CHARGES (Continued)

b. UNI Port Only<sup>1</sup>, each

	Nonrecurring Charge <sup>2</sup>	Monthly Rate
56 Kbps		
Month-to-Month	\$150.00	\$61.00
One Year	0.00	58.00
Three Years	0.00	51.00
Five Years	0.00	45.00
128 Kbps		
Month-to-Month	150.00	107.00
One Year	0.00	101.00
Three Years	0.00	94.00
Five Years	0.00	83.00
256 Kbps		
Month-to-Month	150.00	167.00
One Year	0.00	160.00
Three Years	0.00	152.00
Five Years	0.00	140.00
384 Kbps		
Month-to-Month	150.00	212.00
One Year	0.00	204.00
Three Years	0.00	189.00
Five Years	0.00	172.00
1.536 Mbps		
Month-to-Month	295.00	327.00
One Year	0.00	315.00
Three Years	0.00	297.00
Five Years	0.00	276.00

<sup>1</sup> Refer to 3.B. preceding for the terms and conditions associated with Port Only digital access facilities.

<sup>2</sup> Applies in lieu of service charges found elsewhere in this Product Guide or other Company Tariffs.

<sup>3</sup> Effective February 15, 2013, Frame Relay Service is grandfathered and is no longer available to new customers. Existing customers may maintain their service; however, term commitment plans may not be renewed. Moves or changes to subscribers' existing service are permissible, but the term commitment per circuit will not be extended. Upon expiration of the term commitment the service will lapse into a month-to-month service arrangement.

Effective: April 1, 2016

---

ADVANCED DATA SERVICES

C. FRAME RELAY SERVICE (FRS)<sup>3</sup> (Continued)

4. RATES AND CHARGES (Continued)

b. UNI Port Only<sup>1</sup>, each (Continued)

	Nonrecurring <u>Charge</u> <sup>2</sup>	Monthly <u>Rate</u>
4 Mbps		
Month-to-Month	\$395.00	\$1,059.00
One Year	0.00	999.00
Three Years	0.00	920.00
Five Years	0.00	847.00
6 Mbps		
Month-to-Month	395.00	1,089.00
One Year	0.00	1,029.00
Three Years	0.00	938.00
Five Years	0.00	878.00
10 Mbps		
Month-to-Month	395.00	1,120.00
One Year	0.00	1,059.00
Three Years	0.00	968.00
Five Years	0.00	908.00
22 Mbps		
Month-to-Month	395.00	1,150.00
One Year	0.00	1,089.00
Three Years	0.00	999.00
Five Years	0.00	938.00
44.736 Mbps		
Month-to-Month	395.00	1,210.00
One Year	0.00	1,120.00
Three Years	0.00	1,059.00
Five Years	0.00	968.00

<sup>1</sup> Refer to 3.B. preceding for the terms and conditions associated with Port Only digital access facilities.

<sup>2</sup> Applies in lieu of service charges found elsewhere in this Product Guide or other Company Tariffs.

<sup>3</sup> Effective February 15, 2013, Frame Relay Service is grandfathered and is no longer available to new customers. Existing customers may maintain their service; however, term commitment plans may not be renewed. Moves or changes to subscribers' existing service are permissible, but the term commitment per circuit will not be extended. Upon expiration of the term commitment the service will lapse into a month-to-month service arrangement.

Effective: April 1, 2016

---

ADVANCED DATA SERVICES

C. FRAME RELAY SERVICE (FRS)<sup>3</sup> (Continued)

4. RATES AND CHARGES (Continued)

c. NNI Port Only<sup>1</sup>, each

	<u>Nonrecurring Charge</u> <sup>2</sup>	<u>Monthly Rate</u>
384Kbps		
Month-to-Month	\$150.00	\$212.00
One Year	0.00	204.00
Three Years	0.00	189.00
Five Years	0.00	172.00
1.536 Mbps		
Month-to-Month	295.00	327.00
One Year	0.00	315.00
Three Years	0.00	297.00
Five Years	0.00	276.00
44.736 Mbps		
Month-to-Month	395.00	1,210.00
One Year	0.00	1,120.00
Three Years	0.00	999.00
Five Years	0.00	968.00

<sup>1</sup> Refer to 3.B. preceding for the terms and conditions associated with Port Only digital access facilities.

<sup>2</sup> Applies in lieu of service charges found elsewhere in the Product Guide or other Company Tariffs.

<sup>3</sup> Effective February 15, 2013, Frame Relay Service is grandfathered and is no longer available to new customers. Existing customers may maintain their service; however, term commitment plans may not be renewed. Moves or changes to subscribers' existing service are permissible, but the term commitment per circuit will not be extended. Upon expiration of the term commitment the service will lapse into a month-to-month service arrangement.

Effective: April 1, 2016

---

ADVANCED DATA SERVICES

C. FRAME RELAY SERVICE (FRS)<sup>1</sup> (Continued)

4. RATES AND CHARGES (Continued)

d. PVC CIR, per PVC

(1) Intrazone

	<u>Monthly Rate</u>
4 Kbps	\$5.00
8 Kbps	7.00
16 Kbps	8.00
28 Kbps	9.00
32 Kbps	10.00
42 Kbps	13.00
48 Kbps	15.00
64 Kbps	19.00
96 Kbps	26.00
128 Kbps	33.00
192 Kbps	44.00
256 Kbps	51.00
288 Kbps	58.00
384 Kbps	65.00
512 Kbps	73.00
576 Kbps	79.00
768 Kbps	85.00
1152 Kbps	97.00
1536 Kbps	109.00
2 Mbps	116.00
3 Mbps	121.00
4 Mbps	145.00
5 Mbps	172.00
6 Mbps	198.00
7 Mbps	226.00
8 Mbps	251.00
9 Mbps	277.00
10 Mbps	303.00
11 Mbps	322.00
12 Mbps	341.00
13 Mbps	361.00
14 Mbps	380.00
15 Mbps	399.00
16 Mbps	419.00
17 Mbps	438.00
18 Mbps	458.00
19 Mbps	476.00
20 Mbps	496.00
21 Mbps	516.00
22 Mbps	535.00

<sup>1</sup> Effective February 15, 2013, Frame Relay Service is grandfathered and is no longer available to new customers. Existing customers may maintain their service; however, term commitment plans may not be renewed. Moves or changes to subscribers' existing service are permissible, but the term commitment per circuit will not be extended. Upon expiration of the term commitment the service will lapse into a month-to-month service arrangement.



Effective: April 1, 2016

---

ADVANCED DATA SERVICES

C. FRAME RELAY SERVICE (FRS)<sup>2</sup> (Continued)

4. RATES AND CHARGES (Continued)

d. PVC CIR, per PVC (Continued)

(2) Multi-jurisdictional<sup>1</sup>

(3) Public NNI

	<u>Monthly Rate</u>
4 Kbps	\$17.00
8 Kbps	19.00
16 Kbps	20.00
28 Kbps	21.00
32 Kbps	22.00
42 Kbps	25.00
48 Kbps	28.00
64 Kbps	31.00
96 Kbps	36.00
128 Kbps	43.00
192 Kbps	48.00
256 Kbps	61.00
288 Kbps	67.00
384 Kbps	73.00
512 Kbps	85.00
576 Kbps	91.00
768 Kbps	97.00
1152 Kbps	109.00
1536 Kbps	128.00

<sup>1</sup> A Multi-jurisdictional PVC falls under federal jurisdiction and the PVC CIR rates, rules and regulations from the Frontier Operating Companies Tariff FCC No. 8 are applicable.

<sup>2</sup> Effective February 15, 2013, Frame Relay Service is grandfathered and is no longer available to new customers. Existing customers may maintain their service; however, term commitment plans may not be renewed. Moves or changes to subscribers' existing service are permissible, but the term commitment per circuit will not be extended. Upon expiration of the term commitment the service will lapse into a month-to-month service arrangement.

Effective: April 1, 2016

---

ADVANCED DATA SERVICES

C. FRAME RELAY SERVICE (FRS)<sup>1</sup> (Continued)

4. RATES AND CHARGES (Continued)

d. PVC CIR, per PVC (Continued)

(3) Public NNI (Continued)

	<u>Monthly Rate</u>
2 Mbps	\$140.00
3 Mbps	152.00
4 Mbps	164.00
5 Mbps	194.00
6 Mbps	224.00
7 Mbps	254.00
8 Mbps	285.00
9 Mbps	315.00
10 Mbps	345.00
11 Mbps	375.00
12 Mbps	406.00
13 Mbps	436.00
14 Mbps	466.00
15 Mbps	496.00
16 Mbps	520.00
17 Mbps	545.00
18 Mbps	569.00
19 Mbps	593.00
20 Mbps	617.00
21 Mbps	641.00
22 Mbps	666.00

<sup>1</sup> Effective February 15, 2013, Frame Relay Service is grandfathered and is no longer available to new customers. Existing customers may maintain their service; however, term commitment plans may not be renewed. Moves or changes to subscribers' existing service are permissible, but the term commitment per circuit will not be extended. Upon expiration of the term commitment the service will lapse into a month-to-month service arrangement.

Effective: April 1, 2016

---

ADVANCED DATA SERVICES

C. FRAME RELAY SERVICE (FRS)<sup>2</sup> (Continued)

4. RATES AND CHARGES (Continued)

e. PVC CIR Optional Features, per PVC

(1) Interzone Transport <sup>1</sup>

	<u>Monthly Rate</u>
4 Kbps	\$14.00
8 Kbps	15.00
16 Kbps	17.00
28 Kbps	18.00
32 Kbps	19.00
42 Kbps	22.00
48 Kbps	28.00
64 Kbps	33.00
96 Kbps	42.00
128 Kbps	47.00
192 Kbps	65.00
256 Kbps	80.00
288 Kbps	90.00
384 Kbps	100.00
512 Kbps	121.00
576 Kbps	127.00
768 Kbps	138.00
1152 Kbps	160.00
1536 Kbps	176.00

<sup>1</sup> The monthly rate applies in addition to applicable rates for Intrazone PVC CIR.

<sup>2</sup> Effective February 15, 2013, Frame Relay Service is grandfathered and is no longer available to new customers. Existing customers may maintain their service; however, term commitment plans may not be renewed. Moves or changes to subscribers' existing service are permissible, but the term commitment per circuit will not be extended. Upon expiration of the term commitment the service will lapse into a month-to-month service arrangement.

Effective: April 1, 2016

ADVANCED DATA SERVICES

C. FRAME RELAY SERVICE (FRS)<sup>3</sup> (Continued)

4. RATES AND CHARGES (Continued)

e. PVC CIR Optional Features, per PVC (Continued)

(1) Interzone Transport<sup>1</sup>

	<u>Monthly Rate</u>
2 Mbps	\$198.00
3 Mbps	215.00
4 Mbps	226.00
5 Mbps	267.00
6 Mbps	315.00
7 Mbps	362.00
8 Mbps	410.00
9 Mbps	458.00
10 Mbps	506.00
11 Mbps	552.00
12 Mbps	598.00
13 Mbps	645.00
14 Mbps	691.00
15 Mbps	737.00
16 Mbps	774.00
17 Mbps	812.00
18 Mbps	849.00
19 Mbps	887.00
20 Mbps	924.00
21 Mbps	956.00
22 Mbps	988.00

(2) Frame Relay to ATM Service Interworking No Charge

Nonrecurring Charge<sup>2</sup>

f. Subsequent PVC CIR Charge, per PVC CIR	\$40.00
g. Backup UNI, Per Activation	200.00
h. Software Change Charge, Per Order for UNI or Private NNI	40.00

<sup>1</sup> The monthly rate applies in addition to applicable rates for Intrazone PVC CIR.

<sup>2</sup> Applies in lieu of service charges found elsewhere in this Product Guide or other Company Tariffs.

<sup>3</sup> Effective February 15, 2013, Frame Relay Service is grandfathered and is no longer available to new customers. Existing customers may maintain their service; however, term commitment plans may not be renewed. Moves or changes to subscribers' existing service are permissible, but the term commitment per circuit will not be extended. Upon expiration of the term commitment the service will lapse into a month-to-month service arrangement.

Effective: April 1, 2016

---

ADVANCED DATA SERVICES

D. DEDICATED SONET RING (DSR)

1. APPLICATION

This section contains definitions, charges, terms and conditions applicable to the provision of Dedicated SONET Ring (DSR) Service furnished by the Company within the State of California, where conditions and facilities permit.

In addition to the terms and conditions set forth in this section, DSR is also subject to the provisions of the Facilities for Intrastate Access Tariff C-1, except that, in the event of conflict, the provisions of this section shall take precedence. DSR may be resold but no resale discount from the Company shall be required or shall apply.

Dedicated Sonet Ring (DSR) is available where facilities and conditions permit in all existing Frontier exchanges as listed in Section 5, Sheets 2 and 3. The Company concurs in all of the maps filed as part of Southwestern Bell Communications (SBC) Network and Exchange Services tariff, Schedule No. A5.

2. DEFINITIONS

In addition to the General Definitions set forth in Section 1 of this Product Guide, the following definitions apply:

Add/Drop Multiplexing, (ADM) - a multiplexing function that allows lower level signals to be added or dropped from an optical carrier channel.

Node - a DSR rate element and a designation of either a customer location or CO on a SONET ring that has ADM capability. It is also the address of where a lower speed service originates or terminates on a ring.

Fiber Path Diversity - the provision of service using at least two fibers placed on physically separate paths, i.e., different conduit runs that do not pass through the same manhole(s). The cable paths are separated by at least 25 feet.

GigE - an Ethernet circuit offered at the port level over DSR. Ethernet frames are mapped into STS1, STS-N, STS-Nv or STS-Nc SONET frames.

<u>GigE Channel</u>	<u>Transport Bandwidth</u>	<u>Approximate Throughput</u>	<u>Effective SONET Payload Capacity</u>
GigE-1	(1) STS1 or STS1-1v	50 Mbps	49.536 Mbps
GigE-3	(1) STS-3 or STS1-3v	150 Mbps	149.760 Mbps
GigE-6	(1) STS-6 or STS1-6v	300 Mbps	299.520 Mbps
GigE-9	(1) STS-9 or STS1-9v	450 Mbps	449.280 Mbps
GigE-12	(1) STS-12 or STS1-12v	600 Mbps	599.040 Mbps
GigE-24	(1) STS1-21v	1000 Mbps	984.960 Mbps
GigE-24	(1) STS-24	1000 Mbps	1,198.080 Mbps

Effective: April 1, 2016

---

ADVANCED DATA SERVICES

D. DEDICATED SONET RING (DSR) (Continued)

2. DEFINITIONS (Continued)

Optical Carrier Rate, (OC #) - a SONET transmission signal/speed, line rate, or service. The rates are in multiples of an OC1, which is equivalent to a STS1 (51.84 Mbps), SONET's basic rate.

<u>OC(#) Rate</u>	<u>Bandwidth Capacity</u>
3	155.52 Mbps
12	622.08 Mbps
48	2.488 Gbps
192	9.952 Gbps

Optical Carrier Rate Concatenated (OC#c) - a "clear channel" SONET transmission using only one framing format. Generally, an OC3 signal provides three STS1 frame formats with 3 overheads for a total capacity of 2268 bytes per Synchronous Payload Envelope (SPE) frame. For example, in an OC3c signal, one STS3c frame format is used with one overhead, increasing the total payload capacity to 2340 bytes per SPE frame.

DSR Port (Port) - a DSR rate element that denotes the interface at which a lower speed service terminates or originates at a DSR node. The port charge applies both at the entrance to and the exit from the ring.

Port Node - An arrangement on a DSR that interconnects the main DSR ring with a subtending DSR ring.

Subtending Ring - A DSR service that subtends (interconnects with) a DSR main ring.

Synchronous Optical Network (SONET) - an international standard for the transmission of high capacity bandwidth over optical facilities. This synchronous transmission platform utilizes a modular multiplexing approach. Because of the large bandwidth, some of the payload is used to monitor, protect, manage and improve the transmission of the signal.

Synchronous Transport Signal Level (STS1) - a 51.84 Mbps signal that is the electrical equivalent of the OC1 or a DS3 with additional Mbps devoted to SONET overhead information. An STS1 can carry a DS3 or 28 DS1s when specifically formatted (mapped). These DS1s may be accessed off-ring using the Product Guide or Tariffed DS3 to DS1 multiplexing optional service or via a DS3 Transmux port.

Transmuxing - the function of a DSR DS3 Transmux port that performs a DS3 to DS1 conversion at a DSR Node. The DS3 to DS1 conversion allows a single DSR DS3 Transmux port to be associated with up to twenty-eight (28) VT1.5 mapped DSR DS1 ports. Transmuxing within the DSR network retains DS1 visibility, allowing for proactive maintenance capability of DS1 signals.

Virtual Tributary (VT) - a SONET structure designed for transport of sub-STs1 payloads. A DS1 is mapped into the SONET format using a VT1.5 as a packaging mechanism that is internal to the SONET signal.

---

ADVANCED DATA SERVICES

D. DEDICATED SONET RING (DSR) (Continued)

3. TERMS AND CONDITIONS

a. Description of Service

Dedicated Sonet Ring (DSR) is an optical high-capacity service using SONET-based technology.

DSR provides the customer a dedicated, high-capacity customized network. The network is a ring architecture that provides connectivity to multiple customer locations. Full rings may subtend (interconnect with) each other as described in D.3.c.(2) following.

A full ring must have a minimum of three nodes. At least one of the nodes must be located in a Company Central Office (CO) and one at a customer premises. The fiber path is such that when traversing the ring, the starting node and the end node are the same.

DSR is an alternative to basic High Capacity point-to-point service between multiple customer locations. Monthly rate elements include ports, nodes, mileage and optional features (e.g., Customer Network Management capabilities). Rates are specified in D.4 following.

b. Technical Specifications

Technical specifications are delineated in the following publications:

- Telcordia Document GR-253-CORE; Issue 2, December 1995; Revision 1, December 1997  
"Synchronous Optical Network (SONET) Transport Systems: Common Generic Criteria;"
- Telcordia Document GR-1374-CORE; Issue 1, December 1994; "SONET Inter-Carrier Interface Physical Layer Generic Criteria for Carriers;"
- American National Standard, ANSI T1.105-1995; "Synchronous Optical Network (SONET) - Basic Description including Multiplex Structure, Rates and Formats;"
- Telcordia Document GR-1377-CORE; Issue 5, December 1998; "SONET OC192 Transport System Generic Criteria;"
- American National Standard, ANSI X3.802.3, Telecommunications and information exchange between systems-Local and Metropolitan Areas Networks-Specific Requirements-Part 3, Released 1998; and,
- American National Standard, ANSI X3.802.3z, Supplement to Standard for Information Technology-Local and Metropolitan Area Networks, Part 3, Released 1998.

Effective: April 1, 2016

---

ADVANCED DATA SERVICES

D. DEDICATED SONET RING (DSR) (Continued)

3. TERMS AND CONDITIONS (Continued)

c. Provision of Service

(1) All Rings

When a customer premises node is located in the same building as a Central Office node, there may not be diversity between the two nodes.

Generally, a transmission of twenty (20) or more miles or a transmission through six (6) or more COs will be subject to loss of signal integrity. Additional nodes may be added to maintain signal integrity.

The customer specifies the ring capacity in terms of optical carrier rates. DSR is available in capacities of OC3, OC12, OC48 and OC192. Lower speed services are provided between nodes via ports.

DSR is deployed upon customer request, and is available based on negotiated installation intervals. Where suitable SONET facilities are not available, Special Construction rates and charges may apply.

The customer must provide, at no cost to the Company, suitable and secure space, suitable environmental conditions, and uninterrupted power supply, building entrance facilities, and conduit for placement of the facilities and network equipment at its locations as necessary to provide the service.

The customer will be billed additional charges for any charges levied to the Company for space and power required to place ADMs on the Company's side of the network interface.

The customer may provide a single node and associated port equipment at one of its premises subject to compatibility with the Company's equipment in the COs. This compatibility requires that the customer, at its own expense, uses matching vendor's equipment and maintains the same vintage in software release as the Company. Upon written notification from the Company, the customer has 60 days in which to complete the change out of software. In addition, the customer must configure the node to limit access to the data communications channel of the node.

The Company cannot ensure the performance monitoring of the ring when it is equipped with customer provided nodes.

One or more lower speed node(s) may subtend a higher speed node (e.g., an OC12 node may subtend an OC192 node). Rates and charges apply for both the higher speed node and for each subtending lower speed node provided. Additionally, the appropriate port charge will apply to connect the higher speed node to the subtending lower speed node.

More than one lower speed enhanced node may subtend the same higher speed enhanced node.

The connection between the higher and lower speed nodes is a SONET facility (Subtending Node Facility) between an OCn port on the higher speed node and the lower speed node. OCn ports arranged in this asymmetrical configuration are provided in accordance with D.3.c(2) following and must be of the same optical carrier rate as the OCn port on the higher speed node.



Effective: April 1, 2016

---

ADVANCED DATA SERVICES

D. DEDICATED SONET RING (DSR) (Continued)

3. TERMS AND CONDITIONS (Continued)

c. Provision of Service (Continued)

(1) All Rings (Continued)

When the higher speed enhanced node is located at a customer designated premises, the subtending node(s) must be located at the same customer designated premises

When the higher speed enhanced node is located at a Company wire center, the subtending node(s) may be located within that same wire center or extended to a customer designated premises that is served by that wire center or by a different wire center. When extending the subtending node to a customer designated premises, the SNF is subject to a channel extension charge. When the customer designated premises is not served by the same wire center where the higher speed enhanced node is located, mileage applies between the wire centers involved. Mileage applies in addition to the channel extension charge.

When High Capacity DS1 and DS3 services from the Facilities for Intrastate Access Tariff C-1, or Frontier Operating Companies Tariff FCC No. 14 or No. 13, are connected to a DSR from an off-ring location, applicable port charges will be assessed in lieu of SALs for the on-ring portion of the circuit. The off-ring portion of the circuit will be covered by the applicable rates, terms and conditions of the Facilities for Intrastate Access Tariff C-1, FCC No. 14 or FCC No. 13. The applicable rates, terms and conditions are based on the tariff jurisdiction of the circuit.

Ethernet services are provided on a point-to-point basis between two suitably equipped DSR nodes.

Connection of ethernet or optical private line services to a DSR will be provided on an Individual Case Basis (ICB). When connected to a DSR, such services will be charged as ports and will be subject to terms and conditions in D.3.c.(5) following.

When DSR is ordered under a meet point billing arrangement in which the Company acts as an intermediate carrier as set forth in Frontier Operating Companies Tariff FCC No. 14, at least one node of the DSR ring must be in a Company central office.

The rates, terms and conditions contained in this section for the provision of DSR are applicable to customers whose interstate traffic on the service constitutes 10% or less of the total traffic on that service.

With the order for DSR service, the customer will provide to the Company an estimate of whether the interstate traffic will comprise more than 10%, or less than 10% of total traffic. For existing services, the Company will ask the customer to provide the data the customer uses to determine the percentages of the jurisdiction of their services. See the Facilities for Intrastate Access Tariff C-1, Section VI for conditions.

If the customer's estimate of the interstate traffic on the service involved constitutes more than 10% of the total traffic on that service, the service will be provided in accordance with the applicable rules and regulations of the appropriate interstate tariff.

The facilities for intrastate access provided under this section shall be maintained by the Company. The customer or others may not rearrange, move, disconnect, remove or attempt to repair any facilities for intrastate access provided by the Company, other than by connection or disconnection to any interface means used, except with the written consent of the Company.

Effective: April 1, 2016

---

ADVANCED DATA SERVICES

D. DEDICATED SONET RING (DSR) (Continued)

3. TERMS AND CONDITIONS (Continued)

c. Provision of Service (Continued)

(2) Subtending Rings

The customer may interconnect two or more full rings in a subtending ring configuration subject to the following:

- (a) One of the DSR full rings must be designated as the main ring from which the other DSR full ring(s) will subtend. The main ring must be of equal or greater capacity than each DSR full ring that subtends the main ring. For example, a main ring that is an OC12 DSR can have an OC3 and/or OC12 subtending ring but cannot have an OC48 subtending ring. The number of rings that can subtend a main ring may be limited by the type and capacity of the nodes and port configuration specific to the customer's overall DSR service configuration.
- (b) Interconnection between the main ring and the subtending ring requires a port node. A port node provides high speed interconnection between an enhanced node on the main ring and the high speed facilities of the subtending ring. Each subtending ring requires one port node where the subtending ring is interconnected to an enhanced node on the main ring. Interconnection between the main ring and a subtending ring may occur at a customer designated premises or within a Company wire center where such nodes are located. A maximum of two (2) interconnection points with the main ring are allowed per subtending ring.
- (c) Only DSR full rings that utilize suitably equipped enhanced nodes can be arranged in subtending ring configurations. DSR full rings that utilize nodes that are not enhanced will not be arranged in a subtending ring configuration(s).
- (d) Each DSR full ring included in a subtending ring configuration must be arranged as a unidirectional path switched ring (UPSR) and must use nodes that are enhanced. Bidirectional path switched rings (BLSR) may not be arranged in subtending ring configurations.
- (e) Where two (2) points of interconnection between the subtending ring and the main ring are provided, circuits originating on the main ring may be mapped to the subtending ring and circuits originating on the subtending ring may be mapped to the main ring. Channels mapped across the two interconnecting nodes are subject to Dual Node Cross-connect Channel Mapping charges as described in (l) following.

---

ADVANCED DATA SERVICES

D. DEDICATED SONET RING (DSR) (Continued)

3. TERMS AND CONDITIONS (Continued)

c. Provision of Service (Continued)

(2) Subtending Rings (Continued)

(f) The main ring and any subtending rings associated with the main ring must individually meet the minimum requirement of three nodes. However, only one node for the entire service configuration must be located in a Company wire center. For example, if the main ring has one node located in a Company wire center and two nodes located at customer designated premises, the subtending ring(s) need not have a node that is located in a Company wire center.

- When determining if the minimum number of nodes on a subtending ring has been met, the port node providing interconnection to the main ring is included in the count.
- When determining if the minimum number of nodes on a subtending ring has been met, the enhanced node on the main ring that interconnects with the subtending ring is not included in the count.

(g) Each subtending ring may only interconnect with one main ring.

(h) Subtending ring configurations may be established using new DSR full rings, existing DSR full rings, or a combination of new and existing DSR full rings.

(i) All DSR rings in the same subtending ring configuration must be for the same customer of record.

(j) An example of a subtending ring configuration with two (2) points of interconnection to the main ring is diagrammed below:

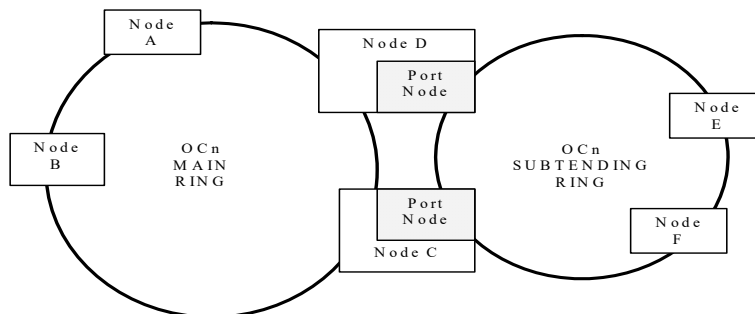

Applicable rate elements:

- Nodes (6)
- Port Node (2)
- Mileage for circumference of Main Ring
- Mileage for circumference of Subtending Ring

---

ADVANCED DATA SERVICES

D. DEDICATED SONET RING (DSR) (Continued)

3. TERMS AND CONDITIONS (Continued)

c. Provision of Service (Continued)

(2) Subtending Rings (Continued)

- (k) Lower speed services provided over DSR must ingress at a node on either ring (the main ring or the subtending ring) and egress DSR at a node on either ring (the subtending ring or the main ring). A single port charge applies at the point of ingress and a single port charge applies at the point of egress, unless the ingress and/or egress occurs via an asymmetrical port facility, in which case a separate port charge will not apply for each such ingress or egress.
- (l) At the customer's option, a lower level service may interconnect the main and one or more of the subtending rings through two separate points of interconnection with each subtending ring. In this case, a Dual Node Cross-connect Charge applies per lower level service provided across the two interconnecting port nodes, regardless of the number of subtending rings involved. The Dual Node Cross-connect Charge does not apply when a lower level service interconnects the main and subtending rings through a single point of interconnection.
- (m) In the event that the customer elects to remove the subtending arrangement ring configuration and make the subtending ring a full DSR that is independent from the main ring, the independent ring must meet all of the requirements for a DSR full ring as set forth in D.3.c.(1) preceding. This may require the addition of an additional node in order to satisfy the minimum node requirement for a single, independent ring.

(3) Mileage

DSR Mileage on a full ring is the total of airline miles between nodes rounded up to the nearest mile.

The mileage rate is based on total ring capacity and not on individual services between nodes. For example, the mileage charge for a four-node OC3 ring with 5.1 miles between each node (20.4 total miles) would be calculated by multiplying the OC3 mileage rate by 21 miles. This mileage calculation applies regardless of the number of services (e.g., DS3s) on the ring.

(4) Port Node

A port node allows interconnection between two full DSR rings. One of the rings will be designated as the main ring and the other ring is designated as a subtending ring.

---

ADVANCED DATA SERVICES

D. DEDICATED SONET RING (DSR) (Continued)

3. TERMS AND CONDITIONS (Continued)

c. Provision of Service (Continued)

(5) DSR Ports

When a lower capacity service is provided between two separate asymmetric port facilities (APF) on the same DSR, the Company must map the facility assignment on the first APF to the facility assignment on the second APF for which an Asymmetrical Port Mapping Nonrecurring Charge applies per lower capacity service mapped.

When a customer transmits STS1, the mapping feature must be designated. The customer must indicate mapping of either individual STSs or concatenated STSs on the ASR.

Ethernet services are provided on a point-to-point basis between two suitably equipped DSR nodes.

Extended Superframe Format (ESF) is required on all DS1 circuits.

Ports may be ordered in a symmetrical arrangement (e.g., DS3 Port to DS3 Port), an asymmetrical arrangement (see table following) or in certain transmuxing arrangements as specified following.

When DS3 transmuxing arrangements are ordered, the following conditions apply:

- The DS3 Transmux Port may connect to Special Access DS3 service as specified in the Facilities for Intrastate Access Tariff C-1, FCC No. 14, and FCC No. 13 for Special Access.
- The DS3 Transmux Port performs a DS3 to a DS1 conversion at a DSR node. The DS3 to DS1 conversion allows a single DSR DS3 Transmux port (which includes a DS3 Transmux Facility to which the DS1 circuits are mapped) to be a facility associated with up to twenty-eight (28) VT1.5 mapped DSR DS1 circuits.
- A DS1 port associated with a DS3 Transmux port may not coexist as a separate DS1 port within the same DSR node.
- An end-to-end DS1 service provided over DSR may not be associated with more than one DS3 Transmux port.
- DS3 Transmux ports are available at customer premises nodes only.
- DS3 Transmux Ports utilize a DS3 Transmux Facility to which VT1.5 mapped DS1 services are associated. Such DS1 services will be provisioned after ordering the associated DS3 Transmux port facility. Transmuxing is only available where suitable facilities and equipment exist to provide the DS3 Transmux Port.

---

ADVANCED DATA SERVICES

D. DEDICATED SONET RING (DSR) (Continued)

3. TERMS AND CONDITIONS (Continued)

c. Provision of Service (Continued)

(5) DSR Ports (Continued)

Asymmetrical ports allow lower level services to be added to, and dropped from DSR, using ports with different transmission rates. For example, a DS1 channel can be added to the ring via a DS3 port and dropped from the ring via a DS1 port. These lower level services may originate and/or terminate at locations that are on or off of the DSR.

For OCn ports, the port with the higher transmission rate provides a facility (Asymmetrical Port Facility or APF, also referred to as a Stub Hub) which is channelized to individual services requiring lower capacity facilities and lower capacity ports. Only one such higher transmission rate OCn port applies per asymmetrical port facility. The number of lower capacity services that can utilize the same APF is limited by the total STS1 capacity of the connecting services. Available transmission rates for the APF are dependent on the capacity of the port to which it is connected. For example, an OC12 APF cannot be established on an OC3 Port. Additionally, the capacity of the port is dependent on the capacity of the node involved.

The APF provides a two-point channelized facility between a customer designated premises or Expanded Interconnection arrangement and the higher transmission rate port of the asymmetrical port combination. Such port may be associated with a node that is located at either the customer designated premises or within a Company wire center.

- (a) When the APF is located at the customer's designated premises, the APF facility is provided between the customer's designated premises and the port on the associated node located at that same premises. Rates and charges for the port apply in accordance with the terms and conditions set forth in D.3.e., following.
- (b) When the APF is located in a Company wire center and the APF connects to a customer designated premises that is served by the same wire center, an asymmetrical port channel extension applies to extend the APF to the customer designated premises. Rates and charges for the asymmetrical port channel extension apply in addition to the rates and charges for the port under D.4, following.
- (c) When the APF is located in a Company wire center and the APF connects to a customer designated premises that is served by a different wire center, an asymmetrical port channel extension and mileage applies to extend the APF to the customer designated premises. Rates and charges for the asymmetrical port channel extension and mileage apply in addition to the rates and charges for the port under D.4, following.

ADVANCED DATA SERVICES

D. DEDICATED SONET RING (DSR) (Continued)

3. TERMS AND CONDITIONS (Continued)

c. Provision of Service (Continued)

(5) DSR Ports (Continued)

Asymmetrical ports are available in the following combinations:

<u>Ring Capacity</u>	<u>Node Speeds</u>	<u>APF Rate</u>	<u>Asymmetrical Port Combination</u>
OC3 DSR Ring	OC3 – OC3	STS1	STS1 – DS3 STS1 – DS1
OC12 DSR Ring	OC12 – OC12	OC3	OC3 – STS1 OC3 – DS3 OC3 – DS1 OC3 – GigE3 OC3 – GigE1
OC48 DSR Ring	OC48 – OC48	OC12	OC12 – OC3 OC12 – OC3c OC12 – STS1 OC12 – DS3 OC12 – DS1 OC12 – GigE12 <sup>1</sup> OC12 – GigE9 <sup>1</sup> OC12 – GigE6 <sup>1</sup> OC12 – GigE3 <sup>1</sup> OC12 – GigE1 <sup>1</sup>
		OC3	OC3 – STS1 OC3 – DS3 OC3 – DS1 OC3 – GigE3 <sup>1</sup> OC3 – GigE1 <sup>1</sup>

<sup>1</sup> For Ethernet (GigE) port options, the associated Ethernet Service must be SONET mapped.

Effective: April 1, 2016

ADVANCED DATA SERVICES

D. DEDICATED SONET RING (DSR) (Continued)

3. TERMS AND CONDITIONS (Continued)

c. Provision of Service (Continued)

(5) DSR Ports (Continued)

Asymmetrical ports are available in the following combinations: (Continued)

<u>Ring Capacity</u>	<u>Node Speeds</u>	<u>APF Rate</u>	<u>Asymmetrical Port Combination</u>
OC192 DSR Ring	OC192 – OC192	OC48	OC48 – OC12
			OC48 – OC12c
			OC48 – OC3
			OC48 – OC3c
			OC48 – STS1
			OC48 – DS3
			OC48 – DS1 <sup>1</sup>
			OC48 – GigE24 <sup>1</sup>
			OC48 – GigE12 <sup>1</sup>
			OC48 – GigE9 <sup>1</sup>
			OC48 – GigE6 <sup>1</sup>
			OC48 – GigE3 <sup>1</sup>
			OC48 – GigE1 <sup>1</sup>
OC12 – OC3c			
OC12 – STS1			
OC12 – DS3			
OC12 – DS1 <sup>1</sup>			
OC12 – GigE12 <sup>1</sup>			
OC12 – GigE9 <sup>1</sup>			
OC12 – GigE6 <sup>1</sup>			
OC12 – GigE3 <sup>1</sup>			
OC12 – GigE1 <sup>1</sup>			
		OC3	OC3 – STS1
			OC3 – DS3
			OC3 – DS1 <sup>1</sup>
			OC3 – GigE3 <sup>1</sup>
			OC3 – GigE1 <sup>1</sup>

<sup>1</sup> For Ethernet (GigE) port options, the associated Ethernet Service must be SONET mapped.



ADVANCED DATA SERVICES

D. DEDICATED SONET RING (DSR) (Continued)

3. TERMS AND CONDITIONS (Continued)

c. Provision of Service (Continued)

(6) An example of an Dedicated Sonet Ring (DSR) ring is diagrammed below:

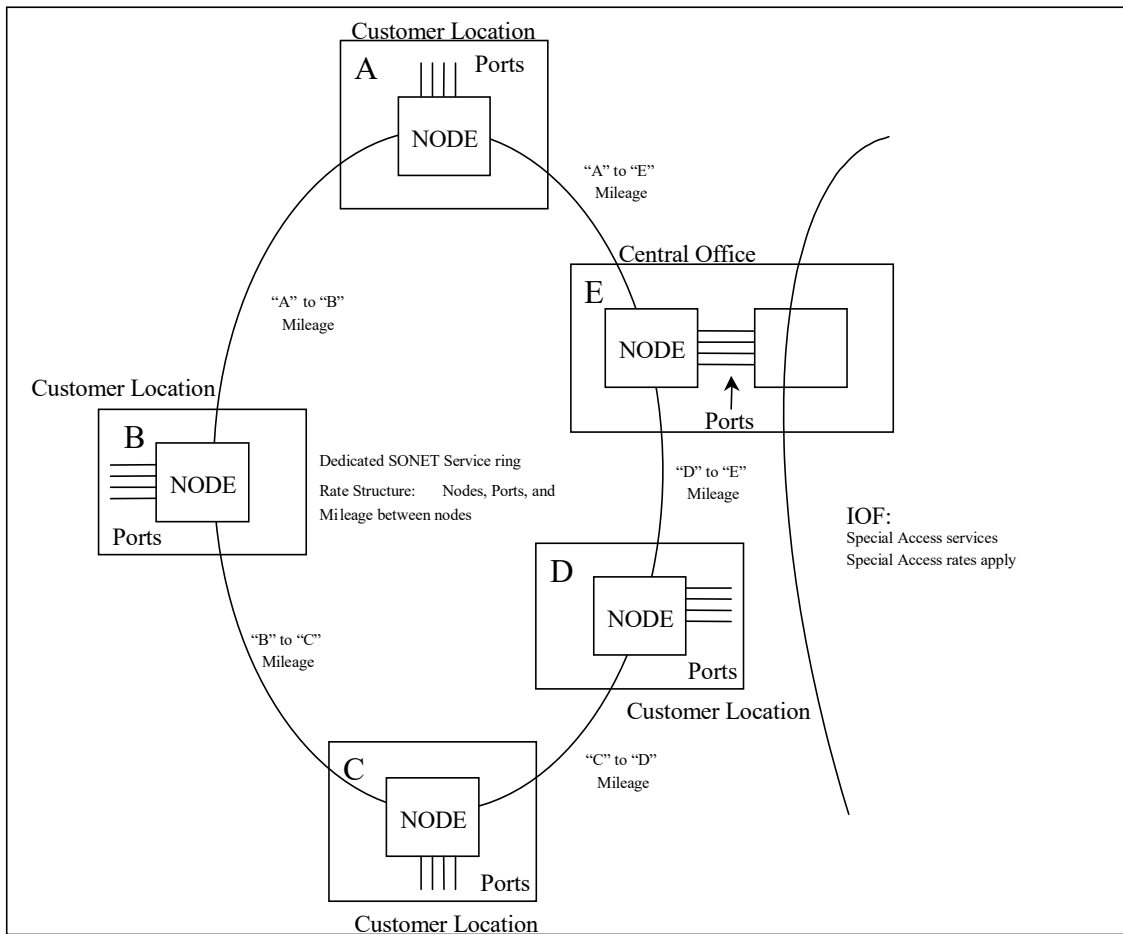

Effective: April 1, 2016

---

ADVANCED DATA SERVICES

D. DEDICATED SONET RING (DSR) (Continued)

3. TERMS AND CONDITIONS (Continued)

d. Optional Feature - Customer Network Management

(1) Description of Service

The customer has the option of purchasing Customer Network Management for use with DSR service provided by the Company. In order to purchase an Optional Feature, the customer must be subscribed to a DSR service and must use such DSR service in conjunction with the selected Optional Feature.

Optional Feature Customer Service Management (CSM) provides a customer with real-time information about the operational status of its DSR network and the ability to reconfigure lower level services riding the DSR ring. Three (3) Service Levels of support are offered for CSM. Each Service Level provides different functionalities to which the customer may gain access. These functionalities are described in the following paragraphs, and include access to real-time information about the customer's DSR network, the ability to generate reports, and the ability to reconfigure lower level services riding the DSR ring.

(2) Provision of Service

The customer must utilize Internet web access to connect its customer-provided terminal equipment to the Company's CSM management system. Access to the Internet and any associated rates and charges are the responsibility of the customer. The customer is also responsible for obtaining communications software

that is compatible with the software the Company utilizes to provide CSM. The Company will work cooperatively with the customer to determine compatibility of its communications software.

CSM may be installed at the same time as the associated DSR ring or may be added to an existing ring, subject to the provisions set forth in D.3.d(3) following, Application of Rates and Charges.

The customer may subscribe to CSM only if the Company provides all nodes on the ring.

When ordering CSM, the customer must specify the level of CSM support as one of the following three (3) Service Levels.

Level 1 support provides a network view of real-time detection and reporting of network alarm conditions within the customer's DSR network.

Level 2 support provides the same support described in Level 1 along with the ability for the customer to generate basic network performance reports for its DSR network. Basic reports are available at no additional charge to the customer. The customer may also request network performance reports that are customized to meet their specific needs. Rates and charges for customized reports are provided on an individual case basis (ICB) only.

---

ADVANCED DATA SERVICES

D. DEDICATED SONET RING (DSR) (Continued)

3. TERMS AND CONDITIONS (Continued)

d. Optional Feature - Customer Network Management (Continued)

(2) Provision of Service (Continued)

Level 3 support provides the same support described in Levels 1 and 2 along with the ability to reconfigure (re-map) the end points of lower level services riding the ring.

Reconfiguration using CSM consists of re-mapping the end point of a primary circuit to its preplanned (backup) port location. The customer must specify a preplanned port location for each primary circuit installed. The preplanned port location is a backup location that is activated and de-activated when a primary circuit is reconfigured at the request of the customer via the CSM platform. A reconfiguration is limited to the mapping of one primary circuit to its assigned preplanned location. For each pre-planned port location, a monthly recurring rate and a nonrecurring installation charge apply per port.

A Company Performed Reconfiguration charge will apply when the customer requests that the Company perform a reconfiguration of service on its behalf. This charge does not apply when a customer performs its own service reconfiguration.

Reconfiguration is not permitted on services arranged in the following service configurations:

- Switched Access Service;
- Service provided under a shared use arrangement;
- Service associated with Centrex-CO or Primary Rate ISDN service; or
- Primary circuits for which the customer has not specified a preplanned backup location.

The type of nodes deployed within the DSR network may limit reconfiguration capability.

When CSM is added to an existing ring, the customer must designate which existing circuits are being made reconfigurable. Nonrecurring charges as set forth in D.4.e will apply. The Company's ability to provide CSM on a particular ring may be limited by the overall configuration of that ring. Reconfiguration is limited to those circuits that originate and/or terminate on the ring (i.e., at locations served by a node on the ring) and utilize ports that are symmetrical. For circuits that originate or terminate off the ring (i.e., at locations not served by a node on the ring), the reconfiguration is limited to customer premises node locations on the ring.

(3) Application of Rates and Charges

CSM rates and charges apply in addition to any applicable DSR rates and charges. Unless otherwise indicated below, CSM rates and charges apply regardless of the Service Level selected by the customer.

Effective: April 1, 2016

---

ADVANCED DATA SERVICES

D. DEDICATED SONET RING (DSR) (Continued)

3. TERMS AND CONDITIONS (Continued)

d. Optional Feature - Customer Network Management (Continued)

(3) Application of Rates and Charges (Continued)

Monthly Recurring Charges

A CSM Service Level rate applies for each DSR ring provided with CSM.

For customers subscribing to Service Level 3 support, a preplanned port rate applies in addition to the DSR port rate for each preplanned port location established.

Nonrecurring Charges

A Node Setup charge applies for each node that is equipped with CSM at the time that CSM is initially established on the ring.

An Initial CSM Setup charge applies for establishment of the customer's initial CSM database partition. The initial CSM database partition includes setup for up to six (6) users. A database partition is a dedicated portion of the CSM platform that can only be accessed by a specific set of users designated by the customer.

A Setup of Additional Partition or Change in CSM Service Level charge applies for the setup of an additional CSM database partition created for the same customer or to change from one CSM service level to another (e.g., change Service Level 2 to Service Level 3). Each additional CSM database provides for the setup of up to six (6) additional users.

A Setup of Additional Users charge applies for the setup of up to six (6) additional users beyond those provided with the initial database setup when CSM is initially established on the ring.

An Add/Remove Node charge applies for each node that is subsequently added to, or removed from, a ring that has already been equipped to provide CSM.

A Company Performed Reconfiguration charge applies for Service Level 3 customers only when the customer requests that the Company perform a reconfiguration based on its pre-mapping instructions.

A Consultation and Support charge applies for each thirty (30) minutes or fraction thereof that the customer requests Company consultation and support of its CSM network. This charge does not apply during initial setup of CSM on the ring.

A Preplanned Port charge applies for Service Level 3 customers only for each preplanned port location that is established during the initial establishment of CSM on the ring.

Effective: April 1, 2016

---

ADVANCED DATA SERVICES

D. DEDICATED SONET RING (DSR) (Continued)

3. TERMS AND CONDITIONS (Continued)

d. Optional Feature - Customer Network Management (Continued)

(3) Application of Rates and Charges (Continued)

CSM Service Level is provided under a term plan of 3 years or 5 years.

The duration of the term plan for CSM Service Level must be the same duration as the term plan for the DSR nodes provided with CSM.

The customer has the option of subscribing to Preplanned Ports on a month-to-month basis or under a term plan of 3 or 5 years. At the expiration of its 3- or 5-Year term plans for CSM Service Levels or Preplanned Ports, the customer has the option of extending CSM Service Level or Preplanned Ports with a coterminous end date.

The expiration date of each CSM Service Level added subsequent to the initial installation must be coterminous to the expiration date of the associated DSR service, provided that the addition is prior to the 21st month for a 3-Year plan, or prior to the 36th month for a 5-Year plan. A CSM added after the aforementioned periods requires extension of the commitment period for the associated DSR service. Such extension results in the establishment of a new plan that includes both the DSR and the CSM under the same plan with the same expiration date.

CSM is subject to termination liability if CSM is removed prior to completion of the existing commitment period. The terms and conditions in D.3.e(3) following, apply to removal of CSM prior to completion of the existing commitment period.

Effective: April 1, 2016

---

ADVANCED DATA SERVICES

D. DEDICATED SONET RING (DSR) (Continued)

3. TERMS AND CONDITIONS (Continued)

e. Application of Rates and Charges

(1) Commitment Periods

DSR is available for 3 or 5-year term commitment periods. Ports and asymmetrical port facilities are also available on a month-to-month basis. Ports, nodes, port nodes, optional features, subtending node facilities, and asymmetrical port facilities added subsequent to the initial installation may be coterminous to the expiration date of the DSR provided the addition is prior to the 21st month for a 3-year plan, or prior to the 36th month for a 5-year plan. Ports, nodes, port nodes, optional features, subtending node facilities, and asymmetrical port facilities added after the aforementioned periods require extending the commitment period for an additional one-year for a 3-year plan, or an additional 2 years for a 5-year plan. Ports and asymmetrical port facilities in a month-to-month plan may be added at anytime. The added nodes must be at the same or lower speed as the existing nodes.

Monthly recurring rates apply for the ports, port nodes, nodes, mileage, optional features, subtending node facilities and asymmetrical port facilities. Once a term period expires, the rates of the customer's existing plan will continue until the customer cancels service or requests a new term plan.

(2) Nonrecurring charges for DSR apply as follows:

- (a) First and Additional charges apply for the initial installation of ports provided on a Month-to-Month term. The First Nonrecurring Charge applies to the first of each port type and speed installed at a node. The Additional Nonrecurring Charge applies for each additional port of the same type and same speed added at the same node on the same order. For example, if a customer places an order for (10) GigE3 Ports at the same OC48 node, one First Nonrecurring Charge and nine Additional Nonrecurring Charges will apply for the GigE3 Ports. A port is charged at each location.
- (b) First and Additional charges apply for the subsequent installation of all ports (whether on a Month-to-Month term or a term pricing plan).
- (c) Subsequent installation of a node or port node.
- (d) Installation of a CSM optional feature. These charges are described in D.3.d(3) preceding.
- (e) An Asymmetrical Port Mapping nonrecurring charge applies for each channel which the Company must map across two separate asymmetrical port facilities on the same DSR. These charges are set forth in D.4 following.

Effective: April 1, 2016

---

ADVANCED DATA SERVICES

D. DEDICATED SONET RING (DSR) (Continued)

3. TERMS AND CONDITIONS (Continued)

e. Application of Rates and Charges (Continued)

(2) Nonrecurring charges for DSR apply as follows: (Continued)

- (f) A Dual Node Cross-connect Charge applies per lower level service provided across the interconnecting port nodes of a subtending ring(s) configuration, regardless of the number of subtending rings involved. Dual Node Cross-connect charges as set forth in D.4 following apply for each channel which the Company must cross-connect between the two port nodes of the interconnecting ring(s).

Changes in Month-to-Month billed ports, port nodes, and asymmetrical port facilities are treated as disconnects and subsequent installations.

When a lower capacity service is dropped from a DSR, the associated ports will be billed to the lower capacity service. Lower capacity services may not be dropped at locations utilizing a pass-through interface. However, a Channel Mapping charge will apply for each lower capacity service that originates at and terminates to devices that are not within the partial ring provided by the Company. The Channel Mapping Charge is billed to the lower capacity service.

When a lower capacity service is provided between two separate asymmetric port facilities (APF) on the same DSR, the Company must map the facility assignment on the first APF to the facility assignment on the second APF for which an Asymmetrical Port Mapping Nonrecurring Charge applies per lower capacity service mapped.

For Storage Interface Ports purchased on a month-to-month basis, nonrecurring charges apply to the installation of ports on a first and additional basis regardless of whether the installation of such Storage Interface Port is in connection with the initial or subsequent installation of DSR.

Where an Ethernet signal is mapped to a SONET service, and that SONET service is provided in a symmetrical port arrangement, two OCn ports apply (one where the mapped signal enters the ring and one where the mapped signal exits the ring).

Where one or more Ethernet signals are mapped to a SONET service, and that SONET service utilizes an asymmetrical port combination (e.g., the signals enter the ring mapped to an OC12 SONET service and exit the ring via an OC48 port associated with an asymmetrical port facility), only one OCn port applies per mapped signal to enter the ring and the signal exits the ring over the asymmetrical port facility. The total number of such mapped Ethernet signals that can be associated with the OCn Port of the asymmetrical port facility is limited by the STS1 capacity required to map each signal into the SONET service. For example, assume that an OC48 APF is ordered for which an OC48 port, OC48 mileage, and, when applicable, an OC48 Extension applies (an OC48 has a capacity of 48 STS1s).

Effective: April 1, 2016

---

ADVANCED DATA SERVICES

D. DEDICATED SONET RING (DSR) (Continued)

3. TERMS AND CONDITIONS (Continued)

e. Application of Rates and Charges (Continued)

(3) Termination Liability

Unless otherwise set forth in this section, termination liability will apply if the customer terminates DSR service or a Customer Network Management Optional Feature prior to the expiration of the selected term commitment period. Termination liability, as set forth in Section 2 of this Product Guide, is charged per monthly rate element on all nodes, ports (other than month-to-month billed ports for which the one month minimum service charge applies), port nodes, optional features, subtending node facilities, and asymmetrical port facilities. A separate termination liability charge is assessed for each rate element associated with the disconnected DSR or Customer Network Management Optional Feature.

DSR service or a Customer Network Management Optional Feature may be canceled without termination liability when cancellation of the service occurs within thirty (30) days of the effective date of a Company initiated rate increase of eight percent (8%) or more on any rate applicable to DSR service or a Customer Network Management Optional Feature.

Termination liability will not apply for any DSR service or Customer Network Management Optional Feature if a customer changes to a longer-term commitment period for the same service, or upgrades to a higher capacity DSR service <sup>1</sup>, if all of the following conditions are met: <sup>2</sup>

- (a) A new commitment period commences with the upgrade.
- (b) The new expiration date must extend beyond the discontinued plan date.
- (c) The upgrade consists of either one (1) DSR being upgraded to a higher capacity DSR, or two (2) existing DSR being upgraded into a single, higher capacity DSR.
- (d) The new DSR has at least one customer premises node and one CO node in common with the discontinued DSR.
- (e) When two (2) existing DSR are being upgraded into a single, higher capacity DSR, the aggregate amount of all monthly charges for the nodes and ports included under the new commitment period is at least 25% greater than the aggregate amount of the monthly charges remaining in the commitment period for the nodes and ports being disconnected.

<sup>1</sup> Upgrades are further subject to the terms and conditions set forth in D.3.e.(1) preceding.

<sup>2</sup> These conditions do not apply to Customer Network Management Optional Features.



Effective: April 1, 2016

---

ADVANCED DATA SERVICES

D. DEDICATED SONET RING (DSR) (Continued)

3. TERMS AND CONDITIONS (Continued)

e. Application of Rates and Charges (Continued)

(4) Moves of Service

A customer can move a node (customer node or CO node) from one location to another location without incurring termination liability providing that all of the following conditions are met:

- (a) A new commitment period commences with the move.
- (b) The new expiration date must extend beyond the discontinued plan date.
- (c) The customer accepts a temporary interruption of the existing service in order to establish the new service.
- (d) The new service is ordered at the same time as the order for disconnection is received.
- (e) A nonrecurring charge will apply to install the node at each new location added to the DSR.

(5) Conversions of Service

Customers who wish to convert existing point-to-point services (e.g. High Capacity DS1 and DS3 services, Custom Connect services) to the Company's DSR may do so without conversion charges (termination liability for the existing service) as long as the total capacity of services purchased by the customer does not decrease.

(6) Extension of a Commitment Period

For DSR, the customer also has the option, within sixty (60) days prior to the expiration date of the commitment period, to extend the expiring term plan to a plan with a longer commitment period. The commitment period selected for the extended plan must be longer than the commitment period of the expiring plan, i.e., an expiring 3-Year Term may be extended to a 5-Year Term Plan.

Time-in-service credit on the expiring plan will be granted and applied towards the new extended plan. For example, an expiring 3-Year term plan will allow for 3 years of time-in-service credit towards a 5-Year extended plan.

The discount associated with the extended plan will apply effective with the first bill date following expiration of the commitment period for the existing plan and will continue through the remainder of the commitment period associated with the extended plan. No adjustment for the increased discount percentage associated with the extended plan will be made to the monthly rates on the expiring plan.

For DSR with a commitment period extended under these terms and conditions, termination liability is calculated as the difference between the monthly rates for the highest commitment period that could have been satisfied prior to disconnection of the service or cancellation of the plan and the monthly rates for the extended commitment period for the period of time the service was in effect.

---

ADVANCED DATA SERVICES

D. DEDICATED SONET RING (DSR) (Continued)

3. TERMS AND CONDITIONS (Continued)

e. Application of Rates and Charges (Continued)

(7) Service Interruption

(a) Credit Allowance Application

Dedicated Sonet Ring (DSR) is interrupted when it becomes unusable to the customer because of a failure of a component used to furnish service as set forth in this section, or when the service is preempted as a result of invoking National Security Emergency Preparedness (NSEP Treatment) or when the application of protective controls interrupt all transmission paths as set forth in the Facilities for Intrastate Access Tariff C-1, Section A.9.

An interruption period starts when Company personnel are notified by the customer that the service is inoperable. The credit allowance(s) for an interruption or for a series of interruptions will be computed based upon the billing method, which applies to the service being credited. In no case will the credit allowance for service interruptions exceed the applicable charges for the billing period during which the interruption occurred.

For DSR, any outage greater than one (1) minute and due solely to a Company facility failure will result in a credit of 100% of the monthly rate for the applicable rate elements of the affected service. Only one such credit is allowed in a single month's billing period.

(b) A Credit Allowance Does Not Apply for Service Interruptions:

- of less than one minute;
- caused by the negligence of the customer or authorized user;
- resulting from the failure of equipment or systems provided by the customer or authorized user;
- during any period in which the Company is not afforded access to a premises for testing and/or repair of service;
- for a negotiated time period during which the customer has released the service to the Company for maintenance purposes, to make rearrangements, or for the implementation of an order for a change in the service. Should the time to perform the maintenance, rearrangement or order for change extend beyond the agreed upon time period, credit allowance will apply for the extended time;
- which continue due to the failure of the customer to authorize replacement of any element of Special Construction. The period during which no credit allowance will be made begins on the seventh day after the customer receives the Company's notification of the need for replacement and ends on the day after the Company receives the customer's authorization for replacement; or
- during periods when the customer elects not to release the service for testing and/or repair, and continues to use it on an impaired basis.

Effective: April 1, 2016

---

ADVANCED DATA SERVICES

D. DEDICATED SONET RING (DSR) (Continued)

3. TERMS AND CONDITIONS (Continued)

e. Application of Rates and Charges (Continued)

(8) Cancellation Charges

(a) The order date for DSR is the date on which the customer provides the Company with a complete and accurate Access Service Request (ASR) for the service. In the event that the customer cancels the request, or part of the request, for construction of the ring, cancellation charges as set forth below will apply.

(b) Cancellation Charges Which Apply After Issuance of the order: per Node or Port Node

	Within the first 30 days of ordering	31 <sup>st</sup> to 60 <sup>th</sup> day after ordering	61 <sup>st</sup> day after ordering to completion of construction
Per OC3 Node	None	\$565.00	\$1,130
Per OC12 Node	None	962.00	1,924
Per OC48 Node	None	2,159	4,318
Per OC192 Node	None	7,010	14,020

(c) Termination Liability as set forth in D.3.e.(3) preceding will apply after the customer has received notification that construction is complete, and the ring has been turned up and accepted by the customer.

Effective: April 1, 2016

ADVANCED DATA SERVICES

D. DEDICATED SONET RING (DSR) (Continued)

4. RATES AND CHARGES

a. DSR Node, each

	<u>Maximum Monthly Rate</u>	<u>Current Monthly Rate</u>	
OC3			
Three Years	\$2,660.00	\$1,330.00	
Five Years	2,580.00	1,290.00	
OC12			
Three Years	5,800.00	2,900.00	
Five Years	5,400.00	2,700.00	
OC48			
Three Years	9,600.00	4,800.00	
Five Years	9,208.00	4,604.00	
OC192			
Three Years	20,000.00	10,000.00	
Five Years	18,400.00	9,200.00	
			<u>Nonrecurring Charge w/ Term Plans</u>
Subsequent Installations, per node or port node		\$1,599.00	

ADVANCED DATA SERVICES

D. DEDICATED SONET RING (DSR) (Continued)

4. RATES AND CHARGES (Continued)

b. Subtending Node Facility (SNF)

(1) Monthly rate, per port node	Maximum Monthly <u>Rate</u>	Current Monthly <u>Rate</u>
Port Node Type -		
OC3 at OC3 Node		
Three Years	\$1,200.00	\$600.00
Five Years	1,000.00	500.00
OC3 at OC12 Node		
Three Years	1,200.00	600.00
Five Years	1,000.00	500.00
OC3 at OC48 Node		
Three Years	1,200.00	600.00
Five Years	1,000.00	500.00
OC3 at OC192 Node		
Three Years	1,200.00	600.00
Five Years	1,000.00	500.00
OC12 at OC12 Node		
Three Years	1,700.00	850.00
Five Years	1,500.00	750.00
OC12 at OC48 Node		
Three Years	1,700.00	850.00
Five Years	1,500.00	750.00
OC12 at OC192 Node		
Three Years	1,700.00	850.00
Five Years	1,500.00	750.00
OC48 at OC48 Node		
Three Years	3,600.00	1,800.00
Five Years	3,200.00	1,600.00
OC48 at OC192 Node		
Three Years	3,600.00	1,800.00
Five Years	3,200.00	1,600.00
OC192 at OC192 Node		
Three Years	9,000.00	4,500.00
Five Years	7,600.00	3,800.00

Effective: April 1, 2016

ADVANCED DATA SERVICES

D. DEDICATED SONET RING (DSR) (Continued)

4. RATES AND CHARGES (Continued)

b. Subtending Node Facility (SNF) (Continued)

(2) Monthly rate, per SNF extended	Maximum Monthly <u>Rate</u>	Current Monthly <u>Rate</u>
SNF Type -		
OC3 SNF		
OC3 Mileage, per mile		
Three Years	\$750.00	\$375.00
Five Years	675.00	337.50
OC3 Channel Extension, each		
Three Years	5,700.00	2,850.00
Five Years	5,130.00	2,565.00
OC12 SNF		
OC12 Mileage, per mile		
Three Years	1,500.00	750.00
Five Years	1,350.00	675.00
OC12 Channel Extension, each		
Three Years	11,000.00	5,500.00
Five Years	9,000.00	4,500.00
OC48 SNF		
OC48 Mileage, per mile		
Three Years	5,250.00	2,625.00
Five Years	4,724.00	2,362.50
OC48 Channel Extension, each		
Three Years	15,000.00	7,500.00
Five Years	12,700.00	6,350.00
(3) Dual Node Cross-Connect Charge, per lower capacity channel provided through two interconnecting nodes in a subtending ring arrangement		
		Nonrecurring <u>Charge</u>
All Channel Types		\$500.00

Effective: April 1, 2016

---

ADVANCED DATA SERVICES

D. DEDICATED SONET RING (DSR) (Continued)

4. RATES AND CHARGES (Continued)

c. DSR Mileage, per mile

	<u>Maximum Monthly Rate</u>	<u>Current Monthly Rate</u>
OC3		
Three Years	\$650.00	\$325.00
Five Years	600.00	300.00
OC12		
Three Years	670.00	335.00
Five Years	640.00	320.00
OC48		
Three Years	900.00	450.00
Five Years	840.00	420.00
OC192		
Three Years	2,780.00	1,390.00
Five Years	2,558.00	1,279.00

ADVANCED DATA SERVICES

D. DEDICATED SONET RING (DSR) (Continued)

4. RATES AND CHARGES (Continued)

d. DSR Port

	<u>Maximum Monthly Rate</u>	<u>Current Monthly Rate</u>
DS1 at OC3 Node		
Month-to-Month	\$110.00	\$55.00
Three Years	110.00	55.00
Five Years	110.00	55.00
DS1 at OC12 Node		
Month-to-Month	110.00	55.00
Three Years	110.00	55.00
Five Years	110.00	55.00
DS1 at OC48 Node		
Month-to-Month	110.00	55.00
Three Years	110.00	55.00
Five Years	110.00	55.00
DS1 at OC192 Node		
Month-to-Month	110.00	55.00
Three Years	110.00	55.00
Five Years	110.00	55.00
DS3 or STS1 at OC3 Node		
Month-to-Month	230.00	115.00
Three Years	230.00	115.00
Five Years	230.00	115.00
DS3 or STS1 at OC12 Node		
Month-to-Month	230.00	115.00
Three Years	230.00	115.00
Five Years	230.00	115.00
DS3 or STS1 at OC48 Node		
Month-to-Month	230.00	115.00
Three Years	230.00	115.00
Five Years	230.00	115.00



Effective: April 1, 2016

---

ADVANCED DATA SERVICES

D. DEDICATED SONET RING (DSR) (Continued)

4. RATES AND CHARGES (Continued)

d. DSR Port (Continued)

	Maximum Monthly Rate	Current Monthly Rate
DS3 or STS1 at OC192 Node		
Month-to-Month	230.00	115.00
Three Years	230.00	115.00
Five Years	230.00	115.00
DS3 Transmux at OC3 Node		
Month-to-Month	800.00	400.00
Three Years	800.00	400.00
Five Years	800.00	400.00
DS3 Transmux at OC12 Node		
Month-to-Month	800.00	400.00
Three Years	800.00	400.00
Five Years	800.00	400.00
DS3 Transmux at OC48 Node		
Month-to-Month	800.00	400.00
Three Years	800.00	400.00
Five Years	800.00	400.00
DS3 Transmux at OC192 Node		
Month-to-Month	800.00	400.00
Three Years	800.00	400.00
Five Years	800.00	400.00
OC3c at OC12 Node		
Month-to-Month	548.00	274.00
Three Years	548.00	274.00
Five Years	548.00	274.00
OC3c at OC48 Node		
Month-to-Month	548.00	274.00
Three Years	548.00	274.00
Five Years	548.00	274.00

Effective: April 1, 2016

ADVANCED DATA SERVICES

D. DEDICATED SONET RING (DSR) (Continued)

4. RATES AND CHARGES (Continued)

d. DSR Port (Continued)

	<u>Maximum Monthly Rate</u>	<u>Current Monthly Rate</u>
OC3c at OC192 Node		
Month-to-Month	\$548.00	\$274.00
Three Years	548.00	274.00
Five Years	548.00	274.00
OC3 at OC12 Node		
Month-to-Month	686.00	343.00
Three Years	686.00	343.00
Five Years	686.00	343.00
OC3 at OC48 Node		
Month-to-Month	686.00	343.00
Three Years	686.00	343.00
Five Years	686.00	343.00
OC3 at OC192 Node		
Month-to-Month	686.00	343.00
Three Years	686.00	343.00
Five Years	686.00	343.00
OC12c at OC48 Node		
Month-to-Month	1,028.00	514.00
Three Years	1,028.00	514.00
Five Years	1,028.00	514.00
OC12c at OC192 Node		
Month-to-Month	1,028.00	514.00
Three Years	1,028.00	514.00
Five Years	1,028.00	514.00
OC12 at OC48 Node		
Month-to-Month	1,284.00	642.00
Three Years	1,284.00	642.00
Five Years	1,284.00	642.00
OC12 at OC192 Node		
Month-to-Month	1,284.00	642.00
Three Years	1,284.00	642.00
Five Years	1,284.00	642.00

ADVANCED DATA SERVICES

D. DEDICATED SONET RING (DSR) (Continued)

4. RATES AND CHARGES (Continued)

d. DSR Port (Continued)

	<u>Maximum Monthly Rate</u>	<u>Current Monthly Rate</u>
OC48c at OC192 Node		
Month-to-Month	\$2,400.00	\$1,200.00
Three Years	2,400.00	1,200.00
Five Years	2,400.00	1,200.00
OC48 at OC192 Node		
Month-to-Month	2,800.00	1,400.00
Three Years	2,800.00	1,400.00
Five Years	2,800.00	1,400.00
GigE1 at OC3 Node		
Month-to-Month	610.00	305.00
Three Years	610.00	305.00
Five Years	610.00	305.00
GigE1 at OC12 Node		
Month-to-Month	610.00	305.00
Three Years	610.00	305.00
Five Years	610.00	305.00
GigE1 at OC48 Node		
Month-to-Month	610.00	305.00
Three Years	610.00	305.00
Five Years	610.00	305.00
GigE1 at OC192 Node		
Month-to-Month	610.00	305.00
Three Years	610.00	305.00
Five Years	610.00	305.00
GigE3 at OC12 Node		
Month-to-Month	690.00	345.00
Three Years	690.00	345.00
Five Years	690.00	345.00
GigE3 at OC48 Node		
Month-to-Month	690.00	345.00
Three Years	690.00	345.00
Five Years	690.00	345.00

ADVANCED DATA SERVICES

D. DEDICATED SONET RING (DSR) (Continued)

4. RATES AND CHARGES (Continued)

d. DSR Port (Continued)

	<u>Maximum Monthly Rate</u>	<u>Current Monthly Rate</u>
GigE3 at OC192 Node		
Month-to-Month	\$690.00	\$345.00
Three Years	690.00	345.00
Five Years	690.00	345.00
GigE6 at OC12 Node		
Month-to-Month	910.00	455.00
Three Years	910.00	455.00
Five Years	910.00	455.00
GigE6 at OC48 Node		
Month-to-Month	910.00	455.00
Three Years	910.00	455.00
Five Years	910.00	455.00
GigE6 at OC192 Node		
Month-to-Month	910.00	455.00
Three Years	910.00	455.00
Five Years	910.00	455.00
GigE9 at OC12 Node		
Month-to-Month	1,070.00	535.00
Three Years	1,070.00	535.00
Five Years	1,070.00	535.00
GigE9 at OC48 Node		
Month-to-Month	1,070.00	535.00
Three Years	1,070.00	535.00
Five Years	1,070.00	535.00
GigE9 at OC192 Node		
Month-to-Month	1,070.00	\$535.00
Three Years	1,070.00	535.00
Five Years	1,070.00	535.00

Effective: April 1, 2016

ADVANCED DATA SERVICES

D. DEDICATED SONET RING (DSR) (Continued)

4. RATES AND CHARGES (Continued)

d. DSR Port (Continued)

	<u>Maximum Monthly Rate</u>	<u>Current Monthly Rate</u>
GigE12 at OC48 Node		
Month-to-Month	\$1,290.00	\$645.00
Three Years	1,290.00	645.00
Five Years	1,290.00	645.00
GigE12 at OC192 Node		
Month-to-Month	1,290.00	645.00
Three Years	1,290.00	645.00
Five Years	1,290.00	645.00
GigE24 at OC48 Node		
Month-to-Month	1,760.00	880.00
Three Years	1,760.00	880.00
Five Years	1,760.00	880.00
GigE24 at OC192 Node		
Month-to-Month	1,760.00	880.00
Three Years	1,760.00	880.00
Five Years	1,760.00	880.00
1Gbps Fibre Channel at OC48 Node		
Month-to-Month	2,000.00	1,000.00
Three Years	2,000.00	1,000.00
Five Years	2,000.00	1,000.00
1Gbps Fibre Channel at OC192 Node		
Month-to-Month	2,000.00	1,000.00
Three Years	2,000.00	1,000.00
Five Years	2,000.00	1,000.00
1 Gbps FICON at OC48 Node		
Month-to-Month	2,000.00	1,000.00
Three Years	2,000.00	1,000.00
Five Years	2,000.00	1,000.00
1 Gbps FICON at OC192 Node		
Month-to-Month	2,000.00	1,000.00
Three Years	2,000.00	1,000.00
Five Years	2,000.00	1,000.00

ADVANCED DATA SERVICES

D. DEDICATED SONET RING (DSR) (Continued)

4. RATES AND CHARGES (Continued)

e. DSR Port, Initial Installation - Nonrecurring Charges

	<u>First</u>	<u>Additional</u>
DS1 Port		
Month-to-month	\$525.00	\$210.00
3 Year Term	N/A	N/A
5 Year Term	N/A	N/A
DS3 or STS1 Port		
Month-to-month	805.00	343.00
3 Year Term	N/A	N/A
5 Year Term	N/A	N/A
DS3 Transmux		
Month-to-month	805.00	343.00
3 Year Term	N/A	N/A
5 Year Term	N/A	N/A
OC3c Port		
Month-to-month	805.00	343.00
3 Year Term	N/A	N/A
5 Year Term	N/A	N/A
OC3 Port		
Month-to-month	805.00	343.00
3 Year Term	N/A	N/A
5 Year Term	N/A	N/A
OC12c Port		
Month-to-month	767.00	327.00
3 Year Term	N/A	N/A
5 Year Term	N/A	N/A
OC12 Port		
Month-to-month	767.00	327.00
3 Year Term	N/A	N/A
5 Year Term	N/A	N/A
OC48c Port		
Month-to-month	767.00	327.00
3 Year Term	N/A	N/A
5 Year Term	N/A	N/A

ADVANCED DATA SERVICES

D. DEDICATED SONET RING (DSR) (Continued)

4. RATES AND CHARGES (Continued)

e. DSR Port, Initial Installation - Nonrecurring Charges (Continued)

	<u>First</u>	<u>Additional</u>
OC48 Port		
Month-to-month	\$767.00	\$327.00
3 Year Term	N/A	N/A
5 Year Term	N/A	N/A
GigE1 Port		
Month-to-month	767.00	327.00
3 Year Term	N/A	N/A
5 Year Term	N/A	N/A
GigE3 Port		
Month-to-month	767.00	327.00
3 Year Term	N/A	N/A
5 Year Term	N/A	N/A
GigE6 Port		
Month-to-month	767.00	327.00
3 Year Term	N/A	N/A
5 Year Term	N/A	N/A
GigE9 Port		
Month-to-month	767.00	327.00
3 Year Term	N/A	N/A
5 Year Term	N/A	N/A
GigE12 Port		
Month-to-month	767.00	327.00
3 Year Term	N/A	N/A
5 Year Term	N/A	N/A
GigE24 Port		
Month-to-month	767.00	327.00
3 Year Term	N/A	N/A
5 Year Term	N/A	N/A
1 Gbps Fibre Channel		
Month-to-month	767.00	578.00
3 Year Term	N/A	N/A
5 Year Term	N/A	N/A
1Gbps FICON		
Month-to-month	767.00	578.00
3 Year Term	N/A	N/A
5 Year Term	N/A	N/A

Effective: April 1, 2016

ADVANCED DATA SERVICES

D. DEDICATED SONET RING (DSR) (Continued)

4. RATES AND CHARGES (Continued)

f. Asymmetrical Port Facility (APF)

(1) Monthly rate, per APF	Maximum Monthly Rate	Current Monthly Rate
APF Type -		
OC3 APF		
OC3 Mileage, per mile		
Month-to-Month	\$1,000.00	\$500.00
Three Years	750.00	375.00
Five Years	675.00	337.50
OC3 Channel Extension, each		
Month-to-Month	7,600.00	3,800.00
Three Years	5,700.00	2,850.00
Five Years	5,130.00	2,565.00
OC12 APF		
OC12 Mileage, per mile		
Month-to-Month	2,000.00	1,000.00
Three Years	1,500.00	750.00
Five Years	1,350.00	675.00
OC12 Channel Extension, each		
Month-to-Month	14,000.00	7,000.00
Three Years	11,000.00	5,500.00
Five Years	9,000.00	4,500.00
OC48 APF		
OC48 Mileage, per mile		
Month-to-Month	7,000.00	3,500.00
Three Years	5,250.00	2,625.00
Five Years	4,725.00	2,362.50
OC48 Channel Extension, each		
Month-to-Month	22,000.00	11,000.00
Three Years	15,000.00	7,500.00
Five Years	12,700.00	6,350.00
(2) APF Mapping Charge, per lower capacity channel mapped between two APFs on the same DSR		Nonrecurring Charge
All Channel Types		\$1,068.00



Effective: April 1, 2016

---

ADVANCED DATA SERVICES

D. DEDICATED SONET RING (DSR) (Continued)

4. RATES AND CHARGES (Continued)

g. Optional Feature - Customer Network Management

Monthly Rates

	Maximum Monthly Rate	Current Monthly Rate
Service Level 1 - Network View only		
Month-to-Month	N/A	N/A
Three Years	\$500.00	\$250.00
Five Years	500.00	250.00
Service Level 2 - Network View & Basic Reports		
Month-to-Month	N/A	N/A
Three Years	900.00	450.00
Five Years	900.00	450.00
Service Level 3 - Network View, Basic Reports & Reconfiguration		
Month-to-Month	N/A	N/A
Three Years	1,700.00	850.00
Five Years	1,700.00	850.00

Pre-planned Port Rates

see D.4.d. for applicable corresponding DSR Port speeds & rates

Effective: April 1, 2016

---

ADVANCED DATA SERVICES

D. DEDICATED SONET RING (DSR) (Continued)

4. RATES AND CHARGES (Continued)

g. Optional Feature - Customer Network Management (Continued)

Nonrecurring Charges

	<u>Nonrecurring Charge</u>
Node Setup, per node on the ring equipped during initial establishment	\$345.00
Initial CSM Setup, first partition with up to six (6) users	500.00
Setup of additional partition, or change in CSM Service Level, each	500.00
Setup of additional users, up to six (6) additional users	350.00
Add/Remove Node, per node	1,500.00
Company performed reconfiguration, per mapping	300.00
Consultation and Support, each thirty (30) minutes or fraction thereof	100.00
Preplanned Port, per port location see D.4.e. preceding for nonrecurring charges for corresponding DSR Port speeds - Initial Installation	

Effective: April 1, 2016

---

ADVANCED DATA SERVICES

E. DEDICATED WAVE LENGTH RING (DWR)

1. APPLICATION

This section contains definitions, charges, terms and conditions applicable to the provision of Dedicated Wavelength Ring (DWR) Service furnished by the Company within the State of California, where conditions and facilities permit.

In addition to the terms and conditions set forth in this section, DWR is also subject to the provisions of the Facilities for Intrastate Access Tariff C-1, except that, in the event of conflict, the provisions of this section shall take precedence. DWR may be resold but no resale discount from the Company shall be required or shall apply.

Dedicated Wave Length Ring (DWR) is available where facilities and conditions permit in all existing Frontier exchanges as listed in Section 5, Sheets 2 and 3. The Company concurs in all of the maps filed as part of Southwestern Bell Communications (SBC) Network and Exchange Services Tariff No. A5.

2. DESCRIPTION OF SERVICE

Dedicated Wavelength Ring (DWR) provides managed optical transport of multiple protocols which are transmitted over a single fiber optic pair. DWR is configured in a diversely routed ring architecture or topology and can be arranged as a full (closed) ring. The ring architecture allows for point-to-point optical services of varying wavelengths to be multiplexed on or off of the ring.

DWR allows for the native transmission of multiple high-speed protocols of various wavelengths over a single customized network. The wavelengths are arranged in a channelized format such that the protocol transmitted over each channel is independent of every other channel on the DWR. The customer must specify, by channel, the interface that defines the transmission speed and protocol being transmitted over the associated wavelength.

3. TERMS AND CONDITIONS

The Dedicare Wavelength Ring (DWR) is comprised of nodes, ring mileage, network optimization (amplification), and optical transport channels

a. Full Ring

A DWR full (closed) ring provides connectivity to multiple customer designated locations (nodes). A full ring must have a minimum of three nodes at different locations or two nodes at different locations with a network optimization mid-span amplifier. At least one of the devices (node or amplifier) must be located in a Central Office (CO) and one must be located at a customer's designated premises.

---

ADVANCED DATA SERVICES

E. DEDICATED WAVE LENGTH RING (DWR) (Continued)

3. TERMS AND CONDITIONS (Continued)

b. Network Design

The Company is responsible for the overall design and configuration of the DWR. Construction of the ring will not begin until such design and configuration are mutually agreeable to both the customer and the Company.

The customer is responsible to ensure that its facilities and equipment meet any applicable technical requirements or limitations for the protocol being transmitted over the optical transport channels.

The technical specifications for DWR are delineated in Technical Publications GR-2918- CORE, Issue 4, GR-2979- CORE, Issue 3, GR-1312- CORE, Issue 3, ITU G.959.1, and ITU G.692.

The Company is responsible for the overall design and configuration of the DWR. Construction of the ring will not begin until such design and configuration are mutually agreeable to both the customer and the Company.

The customer is responsible to ensure that its facilities and equipment meet any applicable technical requirements or limitations for the protocol being transmitted over the optical transport channels.

The technical specifications for DWR are delineated in Technical Publications GR-2918- CORE, Issue 4, GR-2979- CORE, Issue 3, GR-1312- CORE, Issue 3, ITU G.959.1, and ITU G.692.

c. Connection to a Dedicated Wavelength Ring (DWR)

Connection of SONET Connects to a DWR occurs via a protected or unprotected SONET transport channel of an equal speed as follows:

SONET Connects Capacity	Single Port Channel	Multi-port 2.5 Gbps Facility	Multi-port 10 Gbps Facility
OC3/OC3c	SONET OC3/OC3c	SONET OC3/OC3c	
OC12/OC12c	SONET OC12/OC12c	SONET OC12/OC12c	
OC48/OC48c	SONET OC48/OC48c		SONET OC48/OC48c
OC192/OC192c	SONET OC192/OC192c		

ADVANCED DATA SERVICES

E. DEDICATED WAVE LENGTH RING (DWR) (Continued)

3. TERMS AND CONDITIONS (Continued)

c. Connection to a Dedicated Wavelength Ring (DWR) (Continued)

Connection of Dedicated SONET Ring (DSR) to a DWR is provided over an equal speed, unprotected optical transport channel (e.g. a 155.52 Mbps unprotected channel would connect to an OC3 DSR node). Each node on the DSR ring must be located at the same customer designated premises or in the same Company CO as its corresponding DWR node.

Connection of Custom Connect Service to a DWR is provided over an equal speed OC3/OC3c, OC12/OC12c, OC48/OC48c, or OC192/OC192c protected SONET optical transport channel with a 2-fiber or 4-fiber interface or using an equal speed or unprotected optical transport channel with a 2-fiber interface as described in the following section. Protected 4-fiber interfaces are available with single port interfaces only.

Connection of a Frontier Optical Networking to a DWR is provided over an equal speed protected optical transport channel as follows. These services are transported over the DWR using a 2-fiber protected interface or a 4-fiber protected interface.

<u>Frontier Optical Networking Service</u>	<u>Single Port Channel</u>	<u>Multi-port 2.5 Gbps Facility</u>	<u>Multi-port 10 Gbps Facility</u>
OC3c Ethernet to SONET mapped Service	SONET OC3c	SONET OC3c	
GigE12/600 Mbps Ethernet mapped to OC12c Ethernet to SONET mapped	SONET OC12c	SONET OC12c	
1 Gbps Ethernet full rate	Gigabit Ethernet	Gigabit Ethernet	Gigabit Ethernet
1 Gbps FICON Fiber Channel	1 Gbps FICON 1 Gbps Fibre	1 Gbps FICON 1 Gbps Fibre	1 Gbps FICON 1 Gbps Fibre

Connection of a Frontier Optical Networking Gigabit Fibre Channel and/or Gigabit FICON service is provided over a Gigabit Fibre channel and/or Gigabit FICON optical transport channel.

The use of a multi-port interface card requires that all channels on a single card be interrupted during periods when the Company is performing maintenance on that card. No credit for such periods of interruption will apply.

---

ADVANCED DATA SERVICES

E. DEDICATED WAVE LENGTH RING (DWR) (Continued)

4. SERVICE COMPONENTS

a. Nodes

Nodes are Dense Wave Division Multiplexing (DWDM) devices located at customer designated premises or Company wire centers from which optical transport channels are multiplexed on or off of the DWR. The type of node that is deployed at each location is determined by the number of optical transport channels that will be multiplexed on or off of the DWR at that location.

(1) 4-Channel Node

Placement of a 4-channel node at a location enables up to 4 protected optical transport channels to be deployed. Each protected optical channel may be replaced by two unprotected optical channels up to a maximum of 8 possible channels on the node. A 4-channel node may be utilized as the primary node at a location or as an expansion node to expand the capacity of a 16-channel primary node. 4-channel nodes are subject to the availability of suitable facilities and equipment to provide such device. No more than one 4-channel node will be provided at a location.

(2) 16-Channel Node

Placement of a 16-channel node at a location enables up to 16 protected optical transport channels to be deployed. Each protected optical channel may be replaced by two unprotected optical channels up to a maximum of 32 possible channels on the primary node.

The capacity of a 16-channel primary node may be increased through the addition of an expansion node at the same location. A 4-channel expansion node enables up to 20 protected optical transport channels (i.e., 16 on the primary node and 4 on the expansion node) to be deployed at a single location. Each protected optical channel may be replaced by 2 unprotected optical channels up to a maximum of 40 possible channels at that location. A 16-channel expansion node enables up to 32 protected optical transport channels (i.e., 16 on the primary node and 16 on the expansion node) to be deployed at a single location. Each protected optical channel may be replaced by two unprotected optical channels up to a maximum of 64 possible channels at that location.

The maximum number of optical transport channels that can be deployed at a single location is dependent upon the specific configuration of the DWR and the type of optical transport channels being deployed from that location.

The customer will be billed additional charges for any charges levied the Company for space and power required to place nodes on the Company's side of the network interface.

When two nodes are located in the same building there will be no diversity between the two nodes.

---

ADVANCED DATA SERVICES

E. DEDICATED WAVE LENGTH RING (DWR) (Continued)

4. SERVICE COMPONENTS (Continued)

b. Mileage

For full ring service configurations, DWR Mileage is the total of airline distances between devices (nodes and amplifiers) rounded up to the nearest mile. The mileage rate is based on total ring capacity and not on individual services between devices. For example, the mileage charge for a five device ring with two mid-span amplifiers and a distance of 4.3 miles between each device (21.5 total miles) would be calculated by multiplying the mileage rate by 22 miles.

c. Network Optimization/Amplification

Network Optimization provides for amplification of the signal to ensure acceptable optical levels. When required, amplification is performed in a Company CO when mid-span amplification of the signal is required between nodes. Node amplification occurs in one or two directions (East to West and/or West to East). Mid-span amplification occurs simultaneously in both directions (East to West and West to East). The Company shall have sole responsibility in determining when amplification is required and the quantity and type of amplification necessary to maintain acceptable optical levels.

d. Optical Transport Channels

Optical transport channels allow for optical services to be multiplexed on to or off of the DWR at locations equipped with a DWR node. An optical interface at the node allows for connection of the applicable protocol to the customer's equipment. Optical transport channels are provided on a node-to-node (i.e., point-to-point) basis.

A Channel Mapping nonrecurring charge applies in lieu of the rates and charges for a point-to-point transport channel. Optical Transport Channels are available on a protected or unprotected basis depending on the protocol being transmitted and the level of redundancy required for the optical channel. These channels may be ordered using a single-port interface (each a single channel per interface card) or using a multi-port interface. A multi-port interface is a facility capable of supporting up to 4 multi-port channels of ESCON, Fibre Channel, FDDI, Fast Ethernet, D1 Video, or any combination of these multi-port channels. A multi-port optical transport channel provides a two-point facility over the DWR for the purpose of aggregating multiple optical channels over a single wavelength.

Some protocols have facility distance limitations and may affect the design or availability of the DWR or its optical transport channels. The multi-port interface is provided with a short reach, 2-fiber interface with a 1310nm signal. A protected optical channel allows for a single signal from the customer to be duplicated and sent over separate diverse routes (working and protect) within the DWR network. An unprotected optical channel provides minimum protection of the signal from the customer. End-to-end protection is provided by the protection inherent in the connecting service provided by Frontier (e.g., DSR), as applicable.

---

ADVANCED DATA SERVICES

E. DEDICATED WAVE LENGTH RING (DWR) (Continued)

4. SERVICE COMPONENTS (Continued)

d. Optical Transport Channels (Continued)

Optical transport channels are delivered over a single-port interface or multi-port optical transport channel unless otherwise specified. The use of a multi-port optical transport channel and the type of optical transport channels that can be provided over a single-port or multi-port optical transport channel are subject to the availability of suitable equipment to provide the requested service. Multi-port facilities are offered in capacities of 2.5 Gbps or 10 Gbps and are capable of supporting the following channel types, in any combination up to the maximum capacity of the multi-port facility.

2.5 Gbps Multi-port Facility

ESCON  
1 Gbps Fibre Channel  
FDDI  
1 Gbps FICON  
Fast Ethernet  
D1 Video  
SONET OC3/OC3c  
SONET OC12/OC12c  
Gigabit Ethernet

10 Gbps Multi-port Facility

1 Gbps Fibre Channel  
2 Gbps Fibre Channel  
Gigabit Ethernet  
1 Gbps FICON  
2 Gbps FICON  
SONET OC48/OC48c

e. Protocols

All signals generated by customer provided equipment and delivered to the Company for multiplexing on to DWR must meet industry standards and specifications for the underlying protocol. The customer is responsible to perform any error detection and error correction of the data generated by its equipment. The Company assumes no responsibility for the quality of the signal generated by the customer or any customer provided equipment and will deliver the signal to the receiving location in the same format and condition as generated by the customer. The Company will transmit the following protocols over DWR optical transport channels:

SONET OC3 – for transmission of 155.52 Mbps synchronous optical data transmission capability. SONET OC3 is delivered over a 2-fiber or 4-fiber single-port channel or a 2.5 Gbps multi-port channel.

SONET OC3c – for transmission of concatenated 155.52 Mbps synchronous optical data transmission capability. SONET OC3c is delivered over a 2-fiber or 4-fiber single-port channel or a 2.5 Gbps multi-port channel.

SONET OC12 – for transmission of 622.08 Mbps synchronous optical data transmission capability. SONET OC12 is delivered over a 2-fiber or 4-fiber single-port channel or a 2.5 Gbps multi-port channel.

SONET OC12c – for transmission of concatenated 622.08 Mbps synchronous optical data transmission capability. SONET OC12c is delivered over a 2-fiber or 4-fiber single-port channel or a 2.5 Gbps multi-port channel.

SONET OC48 – for transmission of 2.488 Gbps synchronous optical data transmission capability. SONET OC48 is delivered over a 2-fiber or 4-fiber single-port channel or a 10 Gbps multi-port channel.



---

ADVANCED DATA SERVICES

E. DEDICATED WAVE LENGTH RING (DWR) (Continued)

4. SERVICE COMPONENTS (Continued)

e. Protocols (Continued)

SONET OC48c – for transmission of concatenated 2.488 Gbps synchronous optical data transmission capability. SONET OC48c is delivered over a 2-fiber or 4-fiber single-port channel or a 10 Gbps multi-port channel.

SONET OC192 – for transmission of 9.953 Gbps synchronous optical data transmission capability. SONET OC192 is delivered over a 2-fiber or 4-fiber single-port channel only.

SONET OC192c – for transmission of concatenated 9.953 Gbps synchronous optical data transmission capability. SONET OC192c is delivered over a 2-fiber or 4-fiber single-port channel only.

ESCON<sup>1</sup> – for transmission of one 200 Mbps Enterprise Service Connection channel between the same two DWR nodes used for computer-to-computer data exchange. An ESCON signal is limited to a maximum distance of 43km (physical route kilometers) between the locations involved. ESCON is delivered over a 2.5 Gbps multi-port channel only.

FICON<sup>1</sup> – for transmission of 1 Gbps and 2 Gbps Fiber Connection among mainframes, storage devices and peripherals on a single channel. A FICON signal is limited to a maximum distance of 100km (physical route kilometers) between the locations involved. FICON is delivered over a single-port channel, a 2.5 Gbps multi-port channel or a 10 Gbps multi-port channel.

Fibre Channel<sup>1</sup> – for transmission of 2.125 Gbps, 1.0625 Gbps, 531 Mbps, 266 Mbps and 133 Mbps in a serial link between supercomputers, mainframes, workstations, desktop computers, storage devices, displays and other peripherals. A Fiber Channel signal is limited to a maximum distance of 100km (physical route kilometers) between the locations involved. Fiber Channel signals at transmission speeds of 2.125 Gbps, 1.0625 Gbps, 531 Mbps, 266 Mbps, and 133 Mbps are delivered over a single-port channel. Fiber Channel may also be delivered over a multi-port channel as follows:

2.5 Gbps Multi-port Facility

133 Mbps  
266 Mbps  
531 Mbps  
1.0625 Gbps

10 Gbps Multi-port Facility

1.0625 Gbps  
2.125 Gbps

<sup>1</sup> Denotes a data optical transport channel.

---

ADVANCED DATA SERVICES

E. DEDICATED WAVE LENGTH RING (DWR) (Continued)

4. SERVICE COMPONENTS (Continued)

e. Protocols (Continued)

ETR/CLO<sup>1</sup> – a channel for transmission of an 8 Mbps External Timing Reference/Control Link Oscillator signal for distributing time-of-day information to all central processing units in the Sysplex and to keep the Sysplex timer units synchronized with each other. An ETR/CLO signal is limited to a maximum distance of 40km (physical route kilometers) between the locations involved. ETR/CLO is delivered over a single-port channel only.

FDDI<sup>1</sup> – for transmission of 100 Mbps Fiber Distributed Data Interface channels for general purpose interconnection between computers and peripheral equipment, including interconnection of Local Area Networks and other networks. FDDI is delivered over a single-port channel or 2.5 Gbps multi-port channel.

ISC<sup>1</sup> – for transmission of 1.06 Gbps InterSystem Channel for data caching, locking and queuing services between coupling facility and a central processing unit. An ISC signal is limited to a maximum distance of 40km (physical route kilometers) between the locations involved. ISC is delivered over a single-port channel only.

ISC3<sup>1</sup> – for transmission of 2.125 Gbps InterSystem Channel for data caching, locking and queuing services between coupling facility and a central processing unit. An ISC3 signal is limited to a maximum distance of 40 km (physical route kilometers) between the locations involved. ISC3 is delivered over a single-port channel only.

Fast Ethernet<sup>1</sup> – for 100 Mbps transmission of Ethernet. Fast Ethernet is delivered over a single-port or multi-port channel.

Gigabit Ethernet<sup>1</sup> – for 1.0 Gbps transmission of Ethernet. Gigabit Ethernet is delivered over a single-port channel, a 2.5 Gbps multi-port channel, or a 10 Gbps multi-port channel.

10 Gigabit Ethernet LAN-PHY – 10GBASE-R (LAN PHY) interfaces offer an effective line rate of 10.3125 Gbps (10 Gbps of data traffic encoded in a 64B/66B protocol compared to the traditional 8B/10B protocol of Gigabit Ethernet). 10 Gigabit Ethernet LAN-PHY is delivered over a single-port channel only.

10 Gigabit Ethernet WAN-PHY – 10GigE data rate and format compatible with the SONET OC192c transmission format defined by ANSI. 10 Gigabit Ethernet WAN-PHY is delivered over a single-port channel only.

D1 Video<sup>1</sup> – for uncompressed digital transmission of video signals operating at 270 Mbps. D1 Video is delivered over a single-port channel or 2.5 Gbps multi-port channel.

<sup>1</sup> Denotes a data optical transport channel.

Effective: April 1, 2016

---

ADVANCED DATA SERVICES

E. DEDICATED WAVE LENGTH RING (DWR) (Continued)

4. SERVICE COMPONENTS (Continued)

f. Channel Interface Codes

The following channel interface codes are used for the DWR:

NCI

02FMF.4 for 4 Channel Node (Primary or Expansion)  
02FMF.16 for 16 Channel Node (Primary or Expansion)

The following channel interface codes are used for channels using wavelengths on the DWR:

02FCF.10A (FDDI MM 125 Mbps)	02OPF.A02, A04, A07 (266 Mbps Fiber Channel)
02FCF.10A (FDDI SM 125 Mbps)	02OPF.A02, A04, A07 (531 Mbps Fiber Channel)
02FMF.S (DWDM 4-Port 1.25 Gbps)	02OPF.A02, A04, A07 (ESCON)
02LNF.A02, A04, A07 (Fast Ethernet)	02OPF.A02, A04, A07 (ETR/CLO)
02LNF.A02, A04, A07 (Gigabit Ethernet)	02OPF.A02, A04, A07 (ISC)
02LNF.A02 (10 Gigabit Ethernet LAN-PHY)	02SOF.B,D,F,X (SONET OC12/OC12c)
02LNF.A02 (10 Gigabit Ethernet WAN-PHY)	02SOF.B,D,F,X (SONET OC192/192c)
02OPF.A02, A04, A07 (2.125 Gbps Fibre Channel)	02SOF.B,D,F,X (SONET OC3/OC3c)
02OPF.A02, A04, A07 (2.125 Gbps FICON)	02SOF.B,D,F,X (SONET OC48/OC48c)
02OPF.A02, A04, A07 (ISC3 at 2.125Gbps)	02TD6.E (D1 Video)
02OPF.A02, A04, A07 (1.0625 Gbps Fiber Channel)	04SOF.B,D,F,X (SONET OC12/OC12c)
02OPF.A02, A04, A07 (133 Mbps Fiber Channel)	04SOF.B,D,F,X (SONET OC3/OC3c)
02OPF.A02, A04, A07 (1Gbps FICON)	04SOF.B,D,F,X (SONET OC48/OC48c)

ADVANCED DATA SERVICES

E. DEDICATED WAVE LENGTH RING (DWR) (Continued)

4. SERVICE COMPONENTS (Continued)

g. An example of a Dedicated Wavelength Ring is diagrammed below:

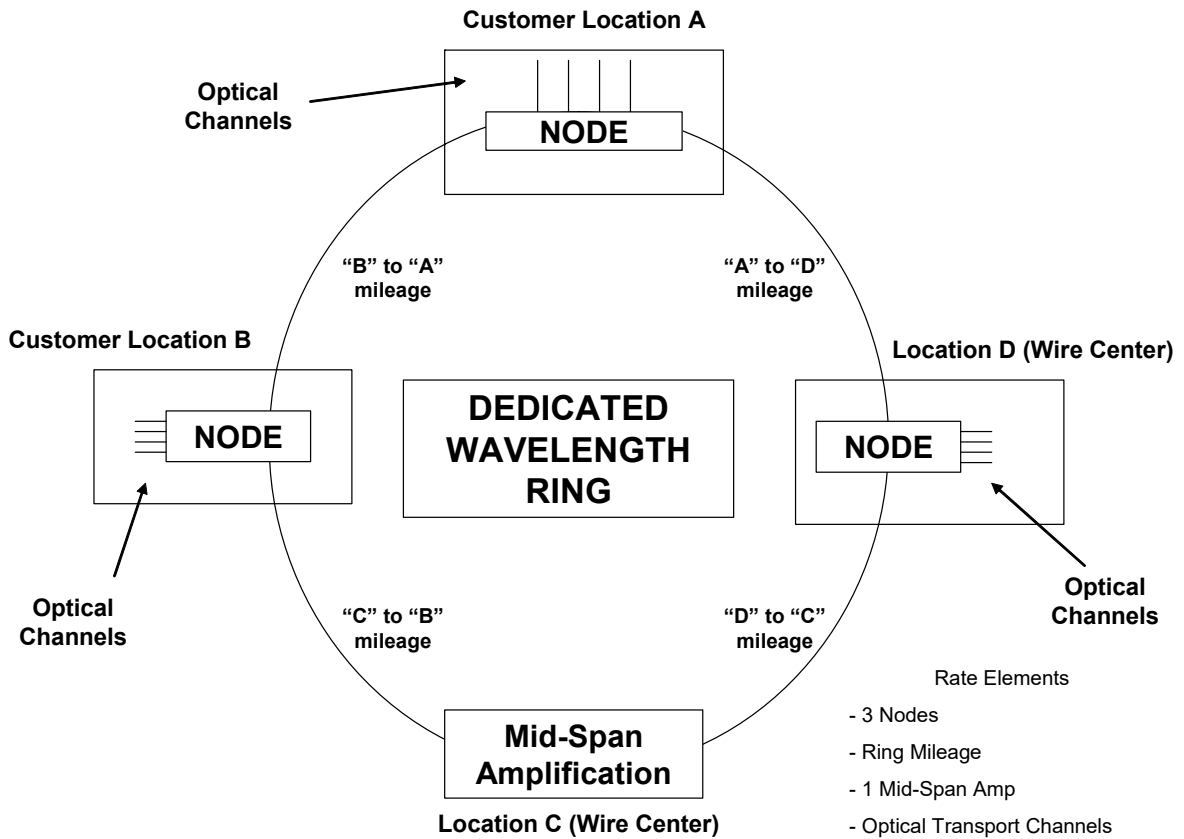

Effective: April 1, 2016

---

ADVANCED DATA SERVICES

E. DEDICATED WAVE LENGTH RING (DWR) (Continued)

5. APPLICATION OF RATES AND CHARGES

a. Commitment Periods

DWR is available for 3-, 5- and 7-year commitment periods for the nodes, ring mileage, network optimization mid-span amplification and optical transport channels. DWR Optical Transport Channels are also available for a 1-year commitment.

Nodes, network optimization mid-span amplification and SONET optical transport channels added subsequent to the initial installation may be coterminous to the expiration date of the DWR at the rates and charges specified for the term plan on the existing DWR or may require an extension to the existing plan as follows:

For all rate elements other than SONET optical transport channels under a 1-year commitment period,

If the addition is prior to the 21st month for an existing 3-year plan, prior to the 36th month for an existing 5-year plan, or prior to the 50th month for an existing 7-year plan, the addition will be coterminous to the expiration date of the DWR.

If the addition is after the aforementioned periods, the customer must extend the commitment period of the existing plan for an additional one-year for a 3-year plan, an additional 2 years for a 5-year plan, or an additional 3 years for a 7-year plan. SONET services associated with DWR are subject to the termination liability set forth in E.5.c following.

For SONET optical transport channels under a 1-year commitment period, the addition will have commitment period that expires one year from the date that billing for the SONET optical transport channel commences. The minimum service period for such channels is three months.

Data optical transport channels (see E.4.f.) added subsequent to the initial installation under a 3-year, 5-year or 7-year commitment period will be coterminous to the expiration date of the DWR at the rates and charges specified for the term plan on the existing DWR. These channels are subject to a minimum service period of three months.

Data optical transport channels under a 1-year commitment period will have a commitment period that expires one year from the date that billing for the SONET optical transport channel commences. The minimum service period for such channels is three months.

The addition of SONET and/or Data optical transport channels subsequent to the initial installation of service may also require the addition of an expansion node(s) and/or network optimization device(s) to accommodate the increase in channels. The addition of an expansion node or network optimization is subject to the conditions set forth above.

Monthly recurring charges apply for the nodes, ring mileage, network optimization, partial ring high speed (pass-through) interfaces (certain partial ring configurations only), and optical transport channels. The monthly rate for an optical transport channel applies for the entire point-to-point connection. The monthly rate for a point-to-fiber-meet optical transport channel applies for the entire node-to-fiber-meet (collocation arrangement in a wire center, premises or mutually agreed upon location, as applicable) connection. Once a term period expires, the prevailing rates of the current plan will continue until the customer cancels service or requests a new term plan.

Effective: April 1, 2016

---

ADVANCED DATA SERVICES

E. DEDICATED WAVE LENGTH RING (DWR) (Continued)

5. APPLICATION OF RATES AND CHARGES (Continued)

a. Commitment Periods (Continued)

When the optical transport channel is provided with a multi-port channel, rates and charges apply for the multi-port facility and for each multi-port channel riding the multi-port facility. When an optical transport channel is delivered over a multi-port channel, the multi-port facility and each multi-port channel riding the multi-port facility must be billed to the same customer who subscribes to the DWR. Once a term period expires, the prevailing rates of the current plan will continue until the customer cancels service or requests a new term plan.

The rates and charges for optical transport channels delivered over a single-port or multi-port interface are set forth in E.7.d. When the optical transport channel is provided with a multi-port interface, rates and charges apply for the multi-port facility and for each multi-port channel riding the multi-port facility.

b. Nonrecurring Charges

Nonrecurring charges for DWR apply for the initial installation of service and for any subsequent node, network optimization mid-span amplification, or optical transport channel that is added at any time after the initial installation of service. A nonrecurring charge also applies to upgrade a 4 channel primary node to a 16 channel primary node or a 4-channel expansion node to a 16-channel expansion node.

A change in the type (e.g., Fiber Channel to FICON, or SONET channel with a 2-fiber interface to SONET channel with a 4-fiber interface) or optical carrier rate (e.g., OC3 to OC12) of optical transport channel is treated as a discontinuance of the existing channel and an installation of a new optical transport channel.

When an optical transport channel is ordered to connect with DSR or Custom Connect, the optical channel will be billed to the DSR or Custom Connect customer, as applicable.

When an optical transport channel is delivered over a multi-port interface, the multi-port facility and each multi-port channel riding the multi-port facility must be billed to the same customer who subscribes to the DWR.

c. Termination Liability

Termination liability applies to DWR and is charged per rate element on all nodes, network optimization, optical transport channels and Network Management Methods. Data optical transport channels as set forth in this section are not subject to termination liability; however, such channels are subject to a minimum service period of three months.

A separate termination liability charge is assessed for each rate element associated with the disconnected DWR or a Network Management Method. For a customer who subscribes to a DWR ring that is arranged with the Direct TL1 Monitoring Optional Feature, as set forth in E.6.b following, if that customer disconnects the DWR ring along with the Direct TL1 Monitoring Optional Feature prior to the end of the commitment period, the customer would pay termination liability on the nodes, network optimization, optical transport channels and the Direct TL1 Monitoring Optional Feature monthly recurring rate elements as set forth in E.7 Rates and Charges.

Effective: April 1, 2016

---

ADVANCED DATA SERVICES

E. DEDICATED WAVE LENGTH RING (DWR) (Continued)

5. APPLICATION OF RATES AND CHARGES (Continued)

c. Termination Liability (Continued)

DWR or a Network Management Method may be canceled without termination liability when cancellation of the DWR or Network Management Method occurs within thirty (30) days of the effective date of a Company initiated rate increase of eight percent (8%) or more on any rate applicable to DWR service or Network Management Method.

Termination liability will not apply (1) if a customer changes its term plan to a longer commitment period; (2) if a 4 channel primary node is upgraded to a 16 channel primary node; or (3) if a 4 channel expansion node is upgraded to a 16 channel expansion node.

Termination liability will apply when the conditions above are not met and the customer cancels service prior to expiration of the plan period.

For all rate elements other than SONET optical transport channels under a 1-Year commitment period, if the cancellation occurs within the first two years of a term plan, termination liability is equal to 100 percent (100%) of the monthly charges for the unexpired portion of the first two years, and 25 percent (25%) of the monthly charges for the remainder of the plan.

If the customer cancels after the first two years of service, then termination liability is equal to 25 percent (25%) of the monthly charges for the remaining life of the term.

For SONET optical transport channels under a 1-year term commitment, if the cancellation occurs prior to completion of the 1-year commitment period, termination liability is equal to 100 percent of the monthly charges for the unexpired portion of the first year.

For Dedicated Wavelength Ring (DWR) Service with a commitment period which was extended, termination liability is calculated as the difference between the monthly rates for the highest Term Pricing Plan commitment period that could have been satisfied prior to disconnection of the service or cancellation of the plan and the monthly rates already paid for the expired commitment period and the extended commitment period for the period of time the service was in effect.

d. Conversions

Customers who wish to move or convert existing Special Access DSR or High Capacity Special Access services to DWR may do so without conversion charges (termination liability and installation charges) as long as the total capacity of Special Access services or DSR purchased by the customer does not decrease.

---

ADVANCED DATA SERVICES

E. DEDICATED WAVE LENGTH RING (DWR) (Continued)

5. APPLICATION OF RATES AND CHARGES (Continued)

e. Extension of a Commitment Period

The customer has the option, within sixty (60) days prior to the expiration date for its commitment period, to extend its expiring Term Pricing Plan to a plan with a longer commitment period, for which time-in-service credit will be allowed for the expiring plan. The commitment period selected for the extended plan must be longer than the commitment period of the expiring plan as follows:

- An expiring 1-Year Term may be extended to a 3-Year, 5-Year or 7-Year Term Plan.
- An expiring 3-Year Term may be extended to either a 5-Year or 7-Year Term Plan.
- An expiring 5-Year Term may be extended to a 7-Year Term Plan.

Time-in-service credit on the expiring plan will be granted and applied towards the new extended plan. For example, an expiring 3-Year term plan will allow for 3 years of time-in-service credit towards the extended plan.

The customer may also extend the commitment period in order to install additional nodes, network optimization devices or SONET optical channels as described in E.5.a preceding.

The rate for the longer commitment period will apply effective with the first bill day following expiration of the commitment period for the existing plan and continue through the remainder of the commitment period associated with the extended plan. No adjustment for the increased discount associated with the extended plan will be made to the monthly rates already billed on the expiring plan.

f. Credit Allowance for Service Interruption

For Dedicated Wavelength Ring (DWR) nodes and network optimization, any single service outage of four hours or more due solely to a Company facility failure will result in a credit of 100% of the monthly rates for the applicable DWR node or network optimization devices affected. Only one such credit is allowed in a single month's billing period.

For DWR Optical Transport Channels, the following credits will be applied.

- For protected Optical Transport Channels, any Company facility failure which is not restored within 1 minute will result in a credit of 100% of the monthly rate for the applicable protected optical channels affected. Only one such credit is allowed in a single month's billing period.
- For unprotected Optical Transport Channels, no credit applies for a service outage on these channels for which no protection is provided by the Company.



---

ADVANCED DATA SERVICES

E. DEDICATED WAVE LENGTH RING (DWR) (Continued)

5. APPLICATION OF RATES AND CHARGES (Continued)

g. Moves and Changes

A move involves a change in the physical location of the Customer designated Premises which also involves a connection to a different rate demarcation point. The charges for the move are dependent on whether the move is to a new location within the same building or to a different building.

a. Moves Within the Same Building

When the move is to a new location within the same building (Inside Move), a nonrecurring charge for the Inside Move will apply. There will be no change in the Minimum Period requirement, and termination liability does not apply.

b. Moves To a Different Building

Moves to a different building (Outside Move) will be treated as a discontinuance and start of Service and all associated nonrecurring charges will apply. New minimum period and/or Service Discount Plan requirements will be established for the new Services. The Customer will also remain responsible for satisfying all outstanding minimum period and/or termination liability charges for the discontinued Service.

h. Cancellation Charges

For DWR, the Company will construct the customer's dedicated ring. The customer must provide the Company with complete and accurate information to design and construct the customer's dedicated ring. Construction will not begin until the customer and the Company agree on the design of the ring. The order date for the ring is the date on which the customer provides the Company with a complete and accurate order for the service. In the event that the customer cancels its request, or part of its request, for construction of the ring, cancellation charges will apply as follows.

Cancellation Charges Which Apply After the Order Date

	<u>31st to 60th day after ordering</u>	<u>61st day after ordering to completion of Ring</u>
- per Primary Node	\$13,000.00	\$26,000.00
- per Expansion Node	26,000.00	52,000.00
- per Mid-span Amp.	5,600.00	10,600.00

---

ADVANCED DATA SERVICES

E. DEDICATED WAVE LENGTH RING (DWR) (Continued)

6. OPTIONAL FEATURES - NETWORK MANAGEMENT

The customer has the option of purchasing one of the following Network Management Methods for use with DWR Special Access service provided by the Company in accordance with this section. Only one method may be provided on a single DWR. Network Management Methods will be available subject to compatibility of the current release of the Network Management Methods software with the DWR equipment deployed for the customer's network.

a. Customer Service Management (CSM)

CSM provides a customer with real-time information about the operational status of its DWR network. CSM provides a network view of real-time detection and reporting of network alarm conditions within the customer's DWR network. In addition, CSM provides the customer with the ability to generate basic network performance reports for its DWR network. The customer may also request network performance reports that are customized to meet their specific needs.

(1) Terms and Conditions

The customer must utilize Internet web access to connect its customer-provided terminal equipment to the Company's CSM management system. Access to the internet and any associated rates and charges are the responsibility of the customer. The customer is also responsible for obtaining communications software that is compatible with the software the Company utilizes to provide CSM. The Company will work cooperatively with the customer to determine compatibility of its communications software.

CSM is provided only when the Company provides all nodes on the ring.

Subject to the restrictions set forth in E.6.a(3) following, CSM is provided coincident with the installation of the associated DWR ring or may be added to an existing ring.

(2) Application of Rates and Charges

A CSM monthly recurring charge applies, per full ring, for each DWR provided with the CSM optional feature.

A Node Setup charge applies, per primary or expansion node, for each node that is equipped with CSM at the time that CSM is initially established on the DWR.

An Initial CSM Setup charge applies for establishment of the customer's initial CSM database partition. The initial CSM database partition includes setup for up to six (6) users.

A Setup of Additional Users charge applies for the setup of up to six (6) additional users beyond those users included with the setup of initial or additional database partitions.

A Setup of Additional Partition charge applies for the setup of an additional CSM database partition created for the same customer. Each additional CSM database partition provides for the setup of up to six (6) additional users.

Effective: April 1, 2016

---

ADVANCED DATA SERVICES

E. DEDICATED WAVE LENGTH RING (DWR) (Continued)

6. OPTIONAL FEATURES - NETWORK MANAGEMENT (Continued)

a. Customer Service Management (CSM) (Continued)

(2) Application of Rates and Charges (Continued)

An Add/Remove Node charge applies, per primary and expansion node, for each node that is added to, or removed from, a DWR equipped with CSM subsequent to the initial establishment of CSM.

A Consultation and Support charge applies for each thirty (30) minutes or fraction thereof that the customer requests Company consultation and support of its CSM network. This charge does not apply during initial setup of CSM.

A Change in Network Management Method charge applies, per primary and expansion node, when the customer requests a change in Network Management Method (e.g., from CSM to DTM).

(3) Rate Conditions

CSM is provided under a term plan of 3 years, 5 years or 7 years, as described following:

- a) The duration of the term plan for CSM must be the same duration as the term plan for the DWR nodes provided with CSM. At the expiration of its 3-, 5- or 7-year term plans for CSM, the customer has the option of extending CSM with a coterminous end date as described following.
- b) The expiration date of each CSM added subsequent to the initial installation must be coterminous to the expiration date of the associated DWR, provided the addition is prior to the 21st month for a 3-year plan, prior to the 36th month for a 5-year plan, or prior to the 50th month for a 7-year plan. A CSM added after the aforementioned periods requires extension of the commitment period for the associated DWR in accordance with this Product Guide. Such extension results in the establishment of a new plan that includes both the DWR and the CSM under the same plan with the same expiration date.

The customer may retrieve basic reports containing performance-monitoring information on its DWR network. Basic reports are available at no additional charge to the customer. The customer may also request that a report be customized to meet its particular needs. Rates and charges for customized reports are provided on an individual case basis (ICB) only.

CSM is subject to termination liability if the service is disconnected prior to completion of the existing commitment period. The terms and conditions in E.5.c apply to termination of CSM prior to completion of the existing commitment period. Changes in Network Management Method (e.g., from CSM to DTM) will be made without termination liability subject to the Add/Remove Node charge described in E.5.a of this section.

---

ADVANCED DATA SERVICES

E. DEDICATED WAVE LENGTH RING (DWR) (Continued)

6. OPTIONAL FEATURES - NETWORK MANAGEMENT (Continued)

b. Direct TL1 Monitoring (DTM)

DTM provides a customer with near real-time information about the operational status of its DWR network over a TL1 connection. A TL1 connection is a machine-to-machine communication language protocol. The connection allows a customer to monitor its DWR network via a limited set of executable TL1 commands in order to query alarm and performance criteria.

DTM enables the following:

- Near real-time access to system-generated alarm and performance messages originating from the customer's DWR network elements.
- Query and response capability that enables two-way communications with the capability to poll and retrieve messages, such as command alarms and performance messages.
- Access to ring inventory information that will enable the customer to maintain its own inventory database containing network element configurations and usage records for active service channels.
- Notification that a power failure has occurred at a DWR network element and that the affected network element has reverted to battery backup.
- Ability to monitor the ring, as well as all service channels riding the ring.

(1) Terms and Conditions

The customer must order two (2) special access services, provided by the Company, in order to ensure secure, dedicated private line access and enable full redundancy for DTM. These special access lines must originate at the customer's designated premises and terminate at a DTM site designated by the Company with the terms and conditions of this section. The customer is responsible for procuring any additional services that may be necessary to connect the special access service to the customer's designated premises.

When requested by the customer, and where technically feasible to do so, the Company will provide encryption capabilities on the Special Access Services used to access DTM. The Company will specify any equipment or software required to provide encryption. Obtaining such equipment or software is the responsibility of the customer. The customer is also responsible for:

- a) Security of any equipment, servers, systems or other facilities provided by the customer and which have access to the DTM network; and
- b) Monitoring access to the DTM service using the facilities, systems, equipment or servers provided by the customers.
- c) DTM is only provided when the Company provides all the nodes on the ring.

Effective: April 1, 2016

---

ADVANCED DATA SERVICES

E. DEDICATED WAVE LENGTH RING (DWR) (Continued)

6. OPTIONAL FEATURES - NETWORK MANAGEMENT (Continued)

b. Direct TL1 Monitoring (DTM) (Continued)

(2) Application of Rates and Charges

A DTM monthly recurring charge applies, per full ring, for each DWR provided with the DTM optional feature.

A Node Setup charge applies, per primary or expansion node, for each node that is equipped with DTM at the time that DTM is initially established on the DWR.

A DTM Setup charge applies for establishment of the customer's DTM database partition.

An Add/Remove Node charge applies, per primary and expansion node, for each node that is added to, or removed from, an DWR ring equipped with DTM subsequent to the initial establishment of DTM.

A Consultation and Support charge applies for each thirty (30) minutes or fraction thereof that the customer requests Company consultation and support of its DTM network. This charge does not apply during initial setup of DTM.

A Change in Network Management Method charge applies, per primary and expansion node, when the customer requests a change in Network Management Method (e.g., from DTM to CSM).

(3) Rate Conditions

DTM is provided under a term plan of 3 years, 5 years or 7 years, as described following.

a) The duration of the term plan for DTM must be the same duration as the term plan for the DWR nodes provided with DTM. At the expiration of its 3-, 5- or 7-year term plans for DTM, the customer has the option of extending DTM with a coterminous end date as described following.

b) The expiration date of each DTM added subsequent to the initial installation must be coterminous to the expiration date of the associated DWR, provided the addition is prior to the 21st month for a 3-year plan, prior to the 36th month for a 5-year plan, or prior to the 50th month for a 7-year plan. A DTM added after the aforementioned periods requires extension of the commitment period for the associated DWR in accordance with this section. Such extension results in the establishment of a new plan that includes both the DWR and the DTM under the same plan with the same expiration date.

Termination liability will apply if DTM is removed prior to completion of the existing commitment period. The terms and conditions in E.5.c apply to termination of DTM prior to completion of the existing commitment period. Changes in Network Management Method (e.g., from DTM to CSM) will be made without termination liability subject to the Add/Remove Node charge set forth in E.5.a of this section.

ADVANCED DATA SERVICES

E. DEDICATED WAVE LENGTH RING (DWR) (Continued)

7. RATES AND CHARGES

a. Nodes, per node

	<u>Monthly Rate</u>	<u>Initial Nonrecurring Charge</u>
<u>4 Channel Nodes (Primary or Expansion)</u>		
3-Year Term	\$6,530.00	\$1.00
5-Year Term	4,900.00	1.00
7-Year Term	4,850.00	1.00
<u>16 Channel Nodes (Primary or Expansion)</u>		
3-Year Term	8,270.00	1.00
5-Year Term	6,200.00	1.00
7-Year Term	6,100.00	1.00
		<u>Nonrecurring Charge</u>
Subsequent Installation or Augmentation, per 4 channel or 16 channel Primary or Expansion node		\$1,600.00
Upgrade to 16 channel Primary or Expansion Node, Per 4 channel Primary or Expansion Node Upgraded		20,000.00

b. Ring Mileage, per mile

	<u>Monthly Rate</u>
3-Year Term	
Mile 1 – 20	\$310.00
Mile 21 and Over	310.00
5-Year Term	
Mile 1 – 20	230.00
Mile 21 and Over	230.00
7-Year Term	
Mile 1 – 20	225.00
Mile 21 and Over	225.00

c. Network Optimization, per amplification device

	<u>Monthly Rate</u>	<u>Initial Nonrecurring Charge</u>
Mid-span 3-Year Term	\$5,130.00	\$1.00
Mid-span 5-Year Term	3,850.00	1.00
Mid-span 7-year Term	3,825.00	1.00
		<u>Nonrecurring Charge</u>
Subsequent Installation, per amplification device	--	\$1,600.00

Effective: April 1, 2016

ADVANCED DATA SERVICES

E. DEDICATED WAVE LENGTH RING (DWR) (Continued)

7. RATES AND CHARGES (Continued)

d. Optical Transport Channels, Point-to-Point Unprotected, Single/Multi-Port Interface

<u>Interface Type</u>	<u>Monthly Rate</u>			
	<u>1-Year Term</u>	<u>3-Year Term</u>	<u>5-Year Term</u>	<u>7-Year Term</u>
Unprotected SONET OC3/OC3c	\$1,905.00	\$1,270.00	\$950.00	\$850.00
Unprotected SONET OC12/OC12c	2,100.00	1,400.00	1,050.00	950.00
Unprotected SONET OC48/OC48c	2,805.00	1,870.00	1,400.00	1,300.00
Unprotected SONET OC192/OC192c	6,900.00	4,600.00	3,450.00	3,350.00
Unprotected 1 Gbps FICON	3,600.00	2,400.00	1,800.00	1,600.00
Unprotected 2 Gbps FICON	3,600.00	2,400.00	1,800.00	1,600.00
Unprotected Fiber Channel	3,600.00	2,400.00	1,800.00	1,600.00
Unprotected 2Gbps Fiber Channel	3,600.00	2,400.00	1,800.00	1,600.00
Unprotected ETR/CLO	3,600.00	2,400.00	1,800.00	1,600.00
Unprotected FDDI	3,600.00	2,400.00	1,800.00	1,600.00
Unprotected 1.06 Gbps ISC	3,600.00	2,400.00	1,800.00	1,600.00
Unprotected 2Gbps ISC3	3,600.00	2,400.00	1,800.00	1,600.00
Unprotected Fast Ethernet	3,600.00	2,400.00	1,800.00	1,600.00
Unprotected Gigabit Ethernet	3,600.00	2,400.00	1,800.00	1,600.00
Unprotected 10Gigabit Ethernet				
LAN-PHY/WAN-PHY	6,900.00	4,600.00	3,450.00	3,350.00
Unprotected D1 Video	3,600.00	2,400.00	1,800.00	1,600.00
Unprotected 2.5Gbps Multi-Port Facility	4,995.00	3,330.00	2,500.00	2,200.00
Unprotected Multi-Port Channel				
ESCON	225.00	225.00	225.00	225.00
Fiber Channel (up to 1Gbps)	225.00	225.00	225.00	225.00
FDDI	225.00	225.00	225.00	225.00
Fast Ethernet	225.00	225.00	225.00	225.00
D1 Video	225.00	225.00	225.00	225.00
OC3/3c	225.00	225.00	225.00	225.00
OC12/12c	225.00	225.00	225.00	225.00
Gigabit Ethernet	225.00	225.00	225.00	225.00
1Gbps FICON	225.00	225.00	225.00	225.00
Unprotected 10Gbps Multi-Port Facility	8,625.00	5,750.00	4,312.50	4,187.50
Unprotected Multi-Port Channel				
Gigabit Ethernet	225.00	225.00	225.00	225.00
1Gbps Fiber Channel	225.00	225.00	225.00	225.00
2Gbps Fiber Channel	225.00	225.00	225.00	225.00
1Gbps FICON	225.00	225.00	225.00	225.00
2Gbps FICON	225.00	225.00	225.00	225.00
OC48/48c	225.00	225.00	225.00	225.00

Effective: April 1, 2016

ADVANCED DATA SERVICES

E. DEDICATED WAVE LENGTH RING (DWR) (Continued)

7. RATES AND CHARGES (Continued)

d. Optical Transport Channels, Point-to-Point Unprotected, Single/Multi-Port Interface (Continued)

<u>Interface Type</u>	<u>Monthly Rate</u>			
	<u>1-Year Term</u>	<u>3-Year Term</u>	<u>5-Year Term</u>	<u>7-Year Term</u>
4-Fiber Protected SONET OC3/OC3c	\$3,810.00	\$2,540.00	\$1,900.00	\$1,700.00
4-Fiber Protected SONET OC12/OC12c	4,200.00	2,800.00	2,100.00	1,900.00
4-Fiber Protected SONET OC48/OC48c	5,610.00	3,740.00	2,800.00	2,600.00
4-Fiber Protected SONET OC192/OC192c	13,800.00	9,200.00	6,900.00	6,700.00
Protected SONET OC3/OC3c	2,400.00	1,600.00	1,200.00	1,100.00
Protected SONET OC12/OC12c	2,595.00	1,730.00	1,300.00	1,200.00
Protected SONET OC48/OC48c	4,305.00	2,870.00	2,150.00	1,925.00
Protected SONET OC192/OC192c	11,205.00	7,470.00	5,600.00	4,750.00
Protected 1 Gbps FICON	4,395.00	2,930.00	2,200.00	1,950.00
Protected 2 Gbps FICON	4,395.00	2,930.00	2,200.00	1,950.00
Protected Fiber Channel	4,395.00	2,930.00	2,200.00	1,950.00
Protected 2Gbps Fiber Channel	4,395.00	2,930.00	2,200.00	1,950.00
Protected FDDI	4,395.00	2,930.00	2,200.00	1,950.00
Protected 1.06 Gbps ISC	4,395.00	2,930.00	2,200.00	1,950.00
Protected 2Gbps ISC3	4,395.00	2,930.00	2,200.00	1,950.00
Protected Fast Ethernet	4,395.00	2,930.00	2,200.00	1,950.00
Protected Gigabit Ethernet	4,395.00	2,930.00	2,200.00	1,950.00
Protected 10Gigabit Ethernet				
LAN-PHY/WAN-PHY	11,205.00	7,470.00	5,600.00	4,750.00
Protected D1 Video	4,395.00	2,930.00	2,200.00	1,950.00
Protected 2.5Gbps Multi-Port Facility	6,000.00	4,000.00	3,000.00	2,700.00
Protected Multi-Port Channel				
ESCON	225.00	225.00	225.00	225.00
Fiber Channel (up to 1Gbps)	225.00	225.00	225.00	225.00
FDDI	225.00	225.00	225.00	225.00
Fast Ethernet	225.00	225.00	225.00	225.00
D1 Video	225.00	225.00	225.00	225.00
OC3/3c	225.00	225.00	225.00	225.00
OC12/12c	225.00	225.00	225.00	225.00
Gigabit Ethernet	225.00	225.00	225.00	225.00
1Gbps FICON	225.00	225.00	225.00	225.00
Protected 10Gbps Multi-Port Facility	14,006.25	9,337.50	7,000.00	5,937.50
Protected Multi-Port Channel				
Gigabit Ethernet	225.00	225.00	225.00	225.00
1Gbps Fiber Channel	225.00	225.00	225.00	225.00
2Gbps Fiber Channel	225.00	225.00	225.00	225.00
1Gbps FICON	225.00	225.00	225.00	225.00
2Gbps FICON	225.00	225.00	225.00	225.00
OC48/48c	225.00	225.00	225.00	225.00



ADVANCED DATA SERVICES

E. DEDICATED WAVE LENGTH RING (DWR) (Continued)

7. RATES AND CHARGES (Continued)

e. Initial and Subsequent Installations - Nonrecurring Charges, Per optical transport channel

<u>Interface Type</u>	<u>Nonrecurring Charge</u>
Unprotected SONET OC3/OC3c	\$1.00
Unprotected SONET OC12/OC12c	1.00
Unprotected SONET OC48/OC48c	1.00
Unprotected SONET OC192/OC192c	1.00
Unprotected 1Gbps FICON	1.00
Unprotected 2Gbps FICON	1.00
Unprotected 1GbpsFiber Channel	1.00
Unprotected 2Gbps Fiber Channel	1.00
Unprotected ETR/CLO	1.00
Unprotected FDDI	1.00
Unprotected 1.06 Gbps ISC	1.00
Unprotected 2Gbps ISC3	1.00
Unprotected Fast Ethernet	1.00
Unprotected Gigabit Ethernet	1.00
Unprotected 10 Gigabit Ethernet (LAN-PHY/WAN-PHY)	1.00
Unprotected D1 Video	1.00
Unprotected 2.5Gbps Multi-Port Facility	1.00
Unprotected Multi-Port Channel	
ESCON	1.00
Fiber Channel (up to 1Gbps)	1.00
FDDI	1.00
Fast Ethernet	1.00
D1 Video	1.00
OC3/3c	1.00
OC12/12c	1.00
Gigabit Ethernet	1.00
1Gbps FICON	1.00
Unprotected 10Gbps Multi-Port Facility	1.00
Unprotected Multi-Port Channel	
Gigabit Ethernet	1.00
1Gbps Fiber Channel)	1.00
2Gbps Fiber Channel	1.00
1Gbps FICON	1.00
2Gbps FICON	1.00
OC48/48c	1.00

ADVANCED DATA SERVICES

E. DEDICATED WAVE LENGTH RING (DWR) (Continued)

7. RATES AND CHARGES (Continued)

e. Initial and Subsequent Installations - Nonrecurring Charges, Per optical transport channel (Continued)

<u>Interface Type</u>	<u>Nonrecurring Charge</u>
4-Fiber Protected SONET OC3/OC3c	\$1.00
4-Fiber Protected SONET OC12/OC12c	1.00
4-Fiber Protected SONET OC48/OC48c	1.00
4-Fiber Protected SONET OC192/OC192c	1.00
Protected SONET OC3/OC3c	1.00
Protected SONET OC12/OC12c	1.00
Protected SONET OC48/OC48c	1.00
Protected SONET OC192/OC192c	1.00
Protected 1 Gbps FICON	1.00
Protected 2 Gbps FICON	1.00
Protected Fiber Channel	1.00
Protected 2Gbps Fiber Channel	1.00
Protected FDDI	1.00
Protected 1.06 Gbps ISC	1.00
Protected 2Gbps ISC3	1.00
Protected Fast Ethernet	1.00
Protected Gigabit Ethernet	1.00
Protected 10 Gigabit Ethernet (LAN-PHY/WAN-PHY)	1.00
Protected D1 Video	1.00
Protected 2.5Gbps Multi-Port Facility	1.00
Protected Multi-Port Channel	
ESCON	1.00
Fiber Channel (up to 1Gbps)	1.00
FDDI	1.00
Fast Ethernet	1.00
D1 Video	1.00
OC3/3c	1.00
OC12/12c	1.00
Gigabit Ethernet	1.00
1Gbps FICON	1.00
Protected 10Gbps Multi-Port Facility	1.00
Protected Multi-Port Channel	
Gigabit Ethernet	1.00
1Gbps Fiber Channel)	1.00
2Gbps Fiber Channel	1.00
1Gbps FICON	1.00
2Gbps FICON	1.00
OC48/48c	1.00

---

ADVANCED DATA SERVICES

E. DEDICATED WAVE LENGTH RING (DWR) (Continued)

7. RATES AND CHARGES (Continued)

f. Optional Features - Network Management Methods

(1) Customer Service Management

	<u>Monthly Rate</u>
CSM, per primary ring	
3 year	\$450.00
5 year	450.00
7 year	450.00
Customized Reports	ICB
	<u>Nonrecurring Charge</u>
Node Setup, per primary or expansion node on the ring equipped during initial CNM Method establishment	\$200.00
Initial CSM Setup, first partition with up to 6 users	500.00
Setup of Additional Partition	500.00
Setup of Additional Users, up to 6 additional users	350.00
Add/Remove Node, per primary or expansion node added to, or removed from, the CSM ring subsequent to initial establishment or for a Change in Network Management Method	200.00
Consultation and Support, each 30 minutes or fraction thereof	100.00
Change Network Management Method, from CSM to DTM, per node	200.00

---

ADVANCED DATA SERVICES

E. DEDICATED WAVE LENGTH RING (DWR) (Continued)

7. RATES AND CHARGES (Continued)

f. Optional Features - Network Management Methods (Continued)

(2) Direct TL1 Monitoring (DTM)

	<u>Monthly Rate</u>
DTM, per primary ring	
3 year	\$450.00
5 year	450.00
7 year	450.00
Customized Reports	ICB
Nonrecurring	
	<u>Charge</u>
Node Setup, per primary or expansion node on the ring equipped during initial DTM establishment	\$200.00
Initial DTM Setup, first partition with up to 6 users	500.00
Add/Remove Node, per primary or expansion node added to, or removed from, the DTM ring subsequent to initial establishment or for a Change in Network Management Method	200.00
Consultation and Support, each 30 minutes or fraction thereof	100.00
Change Network Management Method, from DTM to CSM, per node	200.00

---

ADVANCED DATA SERVICES

F. INTEGRATED OPTICAL SERVICES (IOS)

1. APPLICATION

This section contains definitions, charges, terms and conditions applicable to the provision of Integrated Optical Services (IOS) furnished by the Company within the State of California, where conditions and facilities permit.

In addition to the terms and conditions set forth in this section, IOS is also subject to the provisions of the Facilities for Intrastate Access Tariff C-1, except that, in the event of conflict, the provisions of this section shall take precedence. IOS may be resold but no resale discount from the Company shall be required or shall apply.

INTEGRATED OPTICAL SERVICES (IOS) is available where facilities and conditions permit in all existing Frontier exchanges as listed in Section 5, Sheets 2 and 3. The Company concurs in all of the maps filed as part of Southwestern Bell Communications (SBC) Network and Exchange Services Tariff No. A5.

2. DESCRIPTION OF SERVICE

Integrated Optical Service (IOS) is a dedicated optical network that integrates Dense Wave Division Multiplexing (DWDM), Synchronous Optical Network (SONET), and packet technologies into a single network. An IOS network may be configured specifically to address the Customer's diversity and survivability requirements and may be configured as a single diversely routed ring. The rings are full (closed). The protocols that can be transmitted over IOS include, but are not limited to, time division multiplexing (TDM), SONET, Ethernet, Storage, Video, and mainframe. These services may be protected or unprotected depending on the level of survivability required by the Customer.

IOS is designed with fiber path diversity, which provides two fiber pairs, placed in physically separate paths (e.g. different conduit paths) and separated by at least twenty-five (25) feet. Such 25-foot separation is not required:

on Customer's property, even if past the Point of Termination; b) five hundred (500) feet out from the property line of the Customer Node location; and c) five hundred (500) feet out from any Frontier central office Node location.

IOS provides a high capacity optical network for the delivery of a variety of interfaces and protocols. Each signal (Rider) transported over IOS is provisioned over a single or multiple Facilities of the dedicated optical network.

An IOS full (closed) ring provides connectivity to multiple locations (Nodes) using Facilities and network elements provided solely by Frontier. A minimum of three (3) Nodes are required of which one (1) Node must be located at a Customer designated Premises and one (1) Node must be located in a Frontier Wire Center.

---

ADVANCED DATA SERVICES

F. INTEGRATED OPTICAL SERVICES (IOS) (Continued)

3. ACRONYMS AND DEFINITIONS

a. Acronyms

ANSI - American National Standards Institute  
CSM – Customer Service Management Optional Feature  
DSR – Dedicated SONET Ring  
EPR - Ethernet Packet Ring  
F.C.C. - Federal Communications Commission  
Gbps - Gigabits Per Second  
GigE - Gigabit Ethernet  
HDTV - High Definition Television  
IBT – Intelli Light Broadband Transport  
IOTS - Intelli Light Optical Transport Service  
LAN - Local Area Network  
Mbps - Megabits Per Second  
OC - Optical Carrier  
SLA - Service Level Agreement  
STS - Synchronous Transport Signal  
UNI - User to Network Interface

b. Definitions

Appearance: an IOS rate element that denotes the interface at which a Rider terminates or originates at an IOS Node.

Central Office (CO): A Frontier office or building in which local loops serving a Customer designated Premises in a locality are connected to each other or to a Frontier optical network at such office or building.

Channel(s): an electrical or photonic, in the case of fiber optic-based transmission systems, communications path between two (2) or more points of termination.

Customer(s): any individual, partnership, association, joint-stock company, trust, corporation, or governmental entity or other entity which subscribes to the Services or other arrangements offered under this Product Guide, including both Interexchange Carriers and End Users.

Customer Premises Equipment (CPE): terminal equipment connected to Frontier's network and residing on the Customer designated Premises.

Drop Port Protection: provided on SONET appearances in which a four fiber (4-fiber) 1+1 interface is demarcated. This 1+1 interface is protected against a port failure either on the Frontier side or on the Customer side of the demarcation point.

Facilities: telecommunications cables and equipment owned and utilized by Frontier in the provision of service.

Node: A rate element and a designation of either a Customer designated Premises or CO on an IOS ring that has ADM capability.

---

ADVANCED DATA SERVICES

F. INTEGRATED OPTICAL SERVICES (IOS) (Continued)

3. ACRONYMS AND DEFINITIONS (Continued)

b. Definitions (Continued)

Optical Carrier Rate (OCn): a SONET transmission signal/speed, line rate, or service. The rates are in multiples of an OC1, which is equivalent to an STS1 (51.84 Mbps), SONET's basic rate.

<u>OCn Rate</u>	<u>Bandwidth Capacity</u>
OC3	155.52 Mbps
OC12	622.08 Mbps
OC48	2.488 Gbps
OC192	9.953 Gbps

Optical Carrier Rate Concatenated (OCnc): a "clear channel" SONET transmission using only one (1) framing format. For example, an OC3 signal provides three (3) STS1 frame formats with 3 overheads for a total capacity of 2,268 bytes per SPE frame in an OC3c signal. In an OC3c signal, one (1) STS3c frame format is used with one (1) overhead, increasing the total payload capacity to 2,340 bytes per SPE frame.

Point of Termination: the point of demarcation within the Customer designated Premises at which Frontier's responsibility for the provision of Service ends.

Premises: a building, a portion of a building in a multi-tenant building, or buildings on a continuous property (except Railroad Right-of-Way, etc.) not separated by a public highway.

Service Date: the date that a service has been installed, tested, and made available to the Customer. A confirmed ASR is required to establish a Service Date.

SONET (Synchronous Optical Network): the North American standard for the transmission of high capacity bandwidth over optical Facilities. This synchronous transmission platform utilizes a modular multiplexing approach. Because of the large bandwidth, some of the payload is used to monitor, protect, manage, and improve the transmission of the signal.

Synchronous Transport Signal - Level (STS1): a 51.84 Mbps signal that is the electrical equivalent of the OC1 or a DS3 with additional Mbps devoted to SONET overhead information. The STS1 signal consists of overhead and an SPE. The overhead part of the signal is used for controlling, framing, and maintaining the signal. An STS1 can carry a DS3 or 28 DS1s when specifically formatted (Mapped). However, individual DS1s within a DS3 are not accessible within SONET and their performance cannot be guaranteed for this reason. These DS1s may be accessed using the Special Access DS3-to-DS1 multiplexing optional service.

Wire Center: a Frontier building in which one (1) or more Central Office switches and cross connection equipment used for the provision of Frontier telecommunications services are located.

---

ADVANCED DATA SERVICES

F. INTEGRATED OPTICAL SERVICES (IOS) (Continued)

4. SERVICE COMPONENTS

a. Components

1) Nodes

Nodes are optical networking devices located at Customer designated Premises or Frontier Wire Centers from which Riders are multiplexed on or off of the IOS network. The configuration of an IOS Node that is deployed at each location is determined by the number and type of Riders that are transported between locations.

Each Node allows Protected or Unprotected Riders to be deployed, as described in F.4.a.3) following.

The maximum number of Riders that can be deployed at a single location is dependent upon the specific configuration of the IOS network and the type and quantity of Riders being deployed from that location.

2) Ring Mileage

For full ring service configurations, Ring Mileage is the total of airline distances between devices (Nodes and/or high speed pass-through interfaces) rounded up to the nearest mile. The mileage rate is based on total ring capacity and not on individual services between devices. For example, the mileage charge for a five device ring and a distance of 4.3 miles between each device (21.5 total miles) would be calculated by multiplying the mileage rate by 22 miles.

The mileage between devices located at the same Customer designated Premises or Frontier CO (e.g., dual Nodes at the same Premises) is zero.

The mileage calculation applies regardless of the number of services that are transported over the IOS ring.

3) Riders

Riders allow lower level signals to be transported over the IOS network. Riders allow for optical services to be multiplexed on to or off of the IOS network at locations equipped with a Node. An optical interface at the Node allows for connection of the applicable protocol to the Customer's equipment.

Riders are available on a Protected or Unprotected basis depending on the protocol being transmitted and the level of redundancy required for the Rider. Some protocols have facility distance limitations and may affect the design or availability of the IOS network or its Riders.

- i) Protected Rider - A Protected Rider allows for a single signal from the Customer to be duplicated and sent over separate diverse routes (working and protect) within the IOS network. At the option of the Customer, network Protected Riders may be ordered with Drop Port Protection.
- ii) Unprotected Rider - An Unprotected Rider provides minimum protection of the signal from the Customer. Frontier does not provide route (network level) protection or Drop Port Protection on an Unprotected Rider. However, a Customer purchasing two (2) Unprotected Riders may create their own protection schemes. Riders are provided on a Node-to-Node (i.e., point-to-point) basis.



---

ADVANCED DATA SERVICES

F. INTEGRATED OPTICAL SERVICES (IOS) (Continued)

4. SERVICE COMPONENTS

a. Components (Continued)

3) Riders (Continued)

The services transmitted as Riders over the IOS network include the following protocols:

DS1 (available pursuant to Frontier's Tariff F.C.C. Nos. 14 and/or 16) – for transmission of isochronous serial data at a rate of 1.544 Mbps.

DS3 (available pursuant to Frontier's Tariff F.C.C. Nos. 14 and/or 16) – for transmission of isochronous serial data at a rate of 44.736 Mbps.

SONET OC3 – for transmission of 155.52 Mbps synchronous optical data transmission capability.

SONET OC3c – for transmission of concatenated 155.52 Gbps synchronous optical data transmission capability.

SONET OC12 – for transmission of 622.08 Mbps synchronous optical data transmission capability.

SONET OC12c – for transmission of concatenated 622.08 Gbps synchronous optical data transmission capability.

SONET OC48 – for transmission of 2.488 Gbps synchronous optical data transmission capability.

SONET OC48c – for transmission of concatenated 2.488 Gbps synchronous optical data transmission capability.

SONET OC192 – for transmission of 9.953 Gbps synchronous optical data transmission capability.

SONET OC192c – for transmission of concatenated 9.953 Gbps synchronous optical data transmission capability.

10 Gigabit Ethernet LAN-PHY – 10GBASE-R (LAN PHY) interfaces offer an effective line rate of 10.3125 Gbps (10 Gbps of data traffic encoded in a 64B/66B protocol compared to the traditional 8B/10B protocol of Gigabit Ethernet).

10 Gigabit Ethernet WAN-PHY – 10GigE data rate and format compatible with the SONET OC192c transmission format defined by ANSI.

10 Mbps Ethernet – for 10 Mbps transmission of Ethernet.

---

ADVANCED DATA SERVICES

F. INTEGRATED OPTICAL SERVICES (IOS) (Continued)

4. SERVICE COMPONENTS

a. Components (Continued)

3) Riders (Continued)

The services transmitted as Riders over the IOS network include the following protocols: (Continued)

Fast Ethernet – for 50 Mbps or 100 Mbps transmission of Ethernet.

Gigabit Ethernet – for 1.0 Gbps transmission of Ethernet. Gigabit Ethernet may also be mapped at 50, 100, 150, 300, 450, or 600 Mbps.

Fibre Channel – for full-duplex, serial bit transmission at a link rate of 1, 2, 4 or 10 Gbps Fibre Channel among mainframes, storage devices, and peripherals.

D1 Video – for uncompressed digital transmission of video signals operating at 270 Mbps.

High Definition Video – for uncompressed digital transmission of video signals operating at 1.485Gbps.

When a Rider is ordered to connect with Frontier Optical Networking, Custom Connect or IBT, the Rider will be billed to the Frontier Optical Networking, Custom Connect or IBT Customer, as applicable.

4) Ethernet Packet Ring Service Optional Feature

a) Description

EPRS is available on IOS. EPRS enables switched Ethernet signals to be transmitted over partitioned bandwidth of the Customer's IOS.

The partitioned bandwidth is comprised of STS1 capacity within the IOS that is dedicated to unprotected Ethernet signal transmission between Nodes on that IOS. Ethernet signals must originate at, and terminate to, Nodes that are located at a Customer designated Premises. These Nodes are part of the backbone ring for IOS and are also used to add lower level services onto the backbone ring or to drop lower level services from the backbone ring.

Multiple EPRS partitions may be created on the same IOS. Subject to the preceding paragraph, in no case will the total bandwidth of the EPRS partition(s) exceed the remaining Ocn capacity of the IOS. Ethernet traffic on the EPRS partition may be transmitted in either direction (East to West or West to East) around the ring.

Connection to other Frontier Ethernet services is prohibited.

Frontier does not guarantee the performance of Ethernet signals transported over EPRS.

Monthly rates apply for each EPR Station per Node and to each UNI associated with that EPR Station. Nonrecurring charges apply for the installation of EPRS UNIs on a first and additional basis. Rates and charges EPRS are provided on an individual case basis (ICB) only.

ADVANCED DATA SERVICES

F. INTEGRATED OPTICAL SERVICES (IOS) (Continued)

4. SERVICE COMPONENTS

a. Components (Continued)

4) Ethernet Packet Ring Service Optional Feature (Continued)

b) Service Components of EPRS

EPRS is comprised of EPR Stations and UNIs.

An EPR Station defines the bandwidth required for the partitioned EPRS. A minimum of one EPR Station is required per EPRS. Available EPR Station rates include:

<u>EPR Station Rate</u>	<u>OC12</u>	<u>OC48</u>	<u>OC192</u>
50 Mbps (STS1)	X	X	X
150 Mbps (STS3 or STS3c)	X	X	X
300 Mbps (STS6 or STS6c)	X	X	X
450 Mbps (STS9 or STS9c)	X	X	X
600 Mbps (STS12 or STS12c)		X	X
1000 Mbps (STS21/24 or STS21c/24c)		X	X

UNIs provide access to the EPRS partition on the IOS ring. A minimum of two UNIs is required per EPRS partition. The maximum number of UNIs per EPRS partition is dependent upon the type and capacity of Enhanced Nodes on the IOS. Available UNIs on EPR stations are as follows:

<u>Available UNIs</u>	<u>EPR Station Rate</u>					
	<u>50 Mbps</u>	<u>150 Mbps</u>	<u>300 Mbps</u>	<u>450 Mbps</u>	<u>600 Mbps</u>	<u>1,000 Mbps</u>
10 Mbps UNIs	X	X	X	X	X	X
100 Mbps UNIs	X	X	X	X	X	X
1000 Mbps UNIs	X	X	X	X	X	X

---

ADVANCED DATA SERVICES

F. INTEGRATED OPTICAL SERVICES (IOS) (Continued)

4. SERVICE COMPONENTS

a. Components (Continued)

4) Ethernet Packet Ring Service Optional Feature (Continued)

b) Service Components of EPRS (Continued)

Frontier will disable SONET protection on the portion of the IOS that is partitioned for transmission of Ethernet traffic. No credit applies for a service outage of EPRS, or for any Ethernet signal transported over EPRS, when the SONET protection is disabled by Frontier.

When an EPRS partition is established on an IOS that is also configured with Customer Service Management as set forth in Section 4.b. following, Customer Service Management functionality will not be provided on EPRS or any Ethernet signals transmitted over EPRS.

EPRS cannot be used to access Transparent LAN Service.

b. Customer Service Management (CSM)

Customer Service Management (CSM) provides a customer a view of their IOS network. CSM will be accessible via the internet on the Frontier Business Customer Center (VBCC). CSM will provide inventory and circuit information with regards to the IOS network and all services that ride the IOS.

The Customer may retrieve basic reports containing performance monitoring information on its IOS network. Basic reports are available at no additional charge to the Customer. The Customer may also request that a report be customized to meet its particular needs. Rates and charges for customized reports are provided on an individual case basis (ICB) only.

The Customer must utilize Internet web access to connect its Customer provided terminal equipment to Frontier's CSM management system. Access to the Internet and any associated rates and charges are the responsibility of the Customer. The Customer is also responsible for obtaining communications software that is compatible with the software Frontier utilizes to provide CSM. Frontier will work cooperatively with the Customer to determine compatibility of its communications software.

CSM is provided as part of the IOS offering at no additional charge.

EPRS partitions and Ethernet signals transmitted over such partitions are not accessible via CSM.

---

ADVANCED DATA SERVICES

F. INTEGRATED OPTICAL SERVICES (IOS) (Continued)

5. TECHNICAL SPECIFICATIONS

a. Technical Specifications

The technical specifications for IOS are currently delineated in following Technical References:

DWDM. Technical Publications GR-2918-CORE, Issue 4, GR-2979-CORE, Issue 3, GR-1312-CORE, Issue 3, ITU-T G.959.1 and ITU-T G.692 for DWDM.

SONET. Technical Publications GR-253-CORE, Issue 3, GR-1374-CORE, Issue 1, ANSI T1.105-1995 for SONET.

EPRS. Technical Publication IEEE 802.17 for EPRS.

b. Protocols

The technical publications for the protocols transmitted over IOS are set forth in:

<u>Protocol Transmitted</u>	<u>Technical Publication</u>
DS1, DS3	GR-342, Issue 1, Pub 62411, TR-NPL-000054, TR-EOP-000063 Issue 1
OC3, OC3c, OC12, OC12c, OC48, OC48c, OC192, OC192c	GR-253-CORE, Issue 3
Ethernet (10 Mbps)	ANSI/IEEE 802.3
Fast Ethernet	ANSI/IEEE 802.3u
Gigabit Ethernet	ANSI/IEEE X3.802.3, X3.802.3z
10 Gigabit Ethernet WAN-PHY	IEEE 802.3ae with WAN Interface Sublayer
10 Gigabit Ethernet LAN-PHY	IEEE 802.3ae with LAN Interface Sublayer
Fibre Channel	ANSI/NCITS 404 - 2005 ANSI/NCITS 364 - 2004
D1 Video	ANSI/SMPTE 259M – 1997

Technical specifications are subject to change in accordance with changes adopted by standards-setting industry bodies. Such updates to technical specifications, as they occur, and as determined by Frontier, shall be automatically incorporated without the requirement to amend this section.

ADVANCED DATA SERVICES

F. INTEGRATED OPTICAL SERVICES (IOS) (Continued)

5. TECHNICAL SPECIFICATIONS (Continued)

c. An example of an Integrated Optical Service ring is diagrammed below:

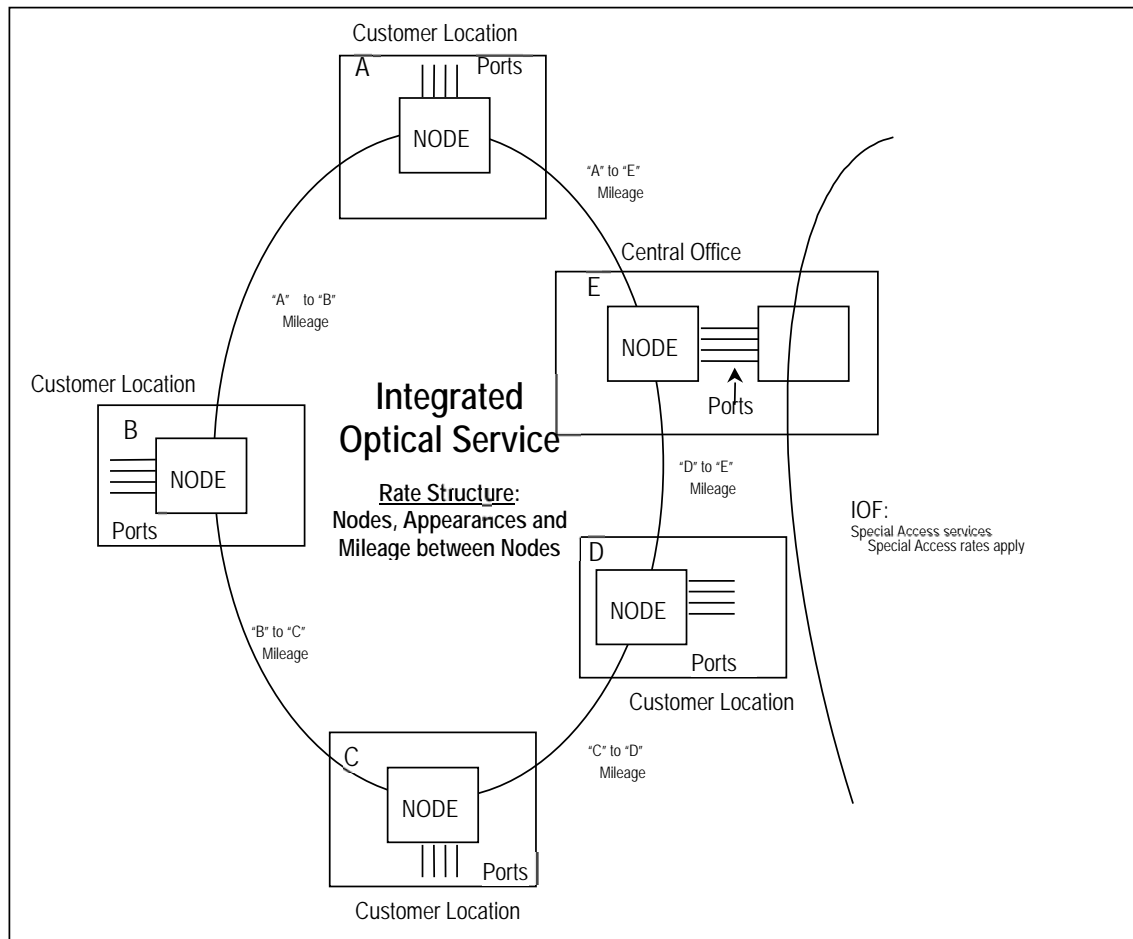

---

ADVANCED DATA SERVICES

F. INTEGRATED OPTICAL SERVICES (IOS) (Continued)

6. TERMS AND CONDITIONS

a. Deployment and Availability

Because IOS is a dedicated high capacity customized network, it is deployed upon Customer request. Where suitable Facilities and equipment are not sufficient or do not exist to provide IOS, Frontier may provide the Service subject to additional special construction, if any. If the Customer agrees to the special construction charges, the Parties shall either enter in to a separate agreement for such special construction, or enter into an amendment to an existing agreement, as mutually agreed to by the Parties.

The provisioning of IOS is based on negotiated intervals between Frontier and the Customer.

b. Connection to Other Services

IOS connects to other Frontier services only as expressly stated herein:

Special Access DS1 and DS3 High Capacity Services - Connection of Special Access DS1 and DS3 High Capacity Services are provided pursuant to Frontier's Tariff F.C.C. Nos. 13 and/or 14.

IBT - Connection of IBT to an IOS network is provided over an equal speed OC3/OC3c, OC12/OC12c, OC48/OC48c, or OC192/OC192c Protected Rider or Protected Rider with Drop Port Protection.

All other applicable IBT terms and conditions apply.

Frontier Optical Networking - Connection of a Frontier Optical Networking Ethernet service to an IOS network is provided over an equal speed protected Ethernet Rider. Connection of a Frontier Optical Networking Ethernet-to-SONET mapped service is provided over an equal speed Protected SONET Rider. All other applicable Frontier Optical Networking terms and conditions apply to the derived Ethernet-to-SONET mapped service.

Available Frontier Optical Networking Service

Interface Connections

10M Ethernet	10BaseT
Fast Ethernet @ 50Mbps	10BaseT or 100FX
Fast Ethernet @ 100Mbps	10BaseT or 100FX
Gigabit Ethernet @ 50Mbps	1000SX or LX
Gigabit Ethernet @ 150Mbps	1000SX or LX
Gigabit Ethernet @ 300Mbps	1000SX or LX
Gigabit Ethernet @ 450Mbps	1000SX or LX
Gigabit Ethernet @ 600Mbps	1000SX or LX
Gigabit Ethernet @ 1000Mbps	1000SX or LX

Effective: April 1, 2016

---

ADVANCED DATA SERVICES

F. INTEGRATED OPTICAL SERVICES (IOS) (Continued)

6. TERMS AND CONDITIONS (Continued)

b. Connection to Other Services (Continued)

Available Frontier Optical Networking Service

Interface Connections (Continued)

10M Ethernet mapped to STS1	OC3, OC12, OC48
Fast Ethernet mapped to STS1	OC3, OC12, OC48
Fast Ethernet mapped to OC3c	OC3c, OC12, OC48
Gigabit Ethernet @ 50Mbps mapped to STS1	OC3, OC12, OC48
Gigabit Ethernet @ 150Mbps mapped to 3 STS1s	OC3, OC12, OC48
Gigabit Ethernet @ 300Mbps mapped to 6 STS1s	OC12, OC48
Gigabit Ethernet @ 450Mbps mapped to 9 STS1s	OC12, OC48
Gigabit Ethernet @ 600Mbps mapped to 12 STS1s	OC12, OC48
Gigabit Ethernet @ 600Mbps mapped to OC12c	OC12c, OC48
Gigabit Ethernet @ 1000Mbps mapped to 21 STS1s	OC48

Custom Connect - Connection of Custom Connect to an IOS network is provided over an equal speed OC3/OC3c, OC12/OC12c, OC48/OC48c, or OC192/OC192c Protected Rider or a Protected Rider with Drop Port Protection (e.g., a 155.52 Mbps Protected Rider would connect to a Custom Connect SONET OC3 service). All other applicable Custom Connect and SONET terms and conditions apply to the derived Custom Connect.

c. Responsibilities of the Parties

The Customer is responsible to ensure that its Facilities and equipment meet any applicable technical requirements or limitations for the protocol being transmitted over IOS.

Frontier is responsible for the overall design and configuration of the IOS network. Construction of the IOS network will not begin until such design and configuration are mutually agreeable to both the Customer and Frontier.

All signals generated by the Customer provided equipment and delivered to Frontier for multiplexing on to IOS must meet industry standards and specifications for the underlying protocol. The Customer is responsible to perform any error detection and error correction of the data generated by its equipment. Frontier assumes no responsibility for the quality of the signal generated by the Customer or any Customer provided equipment and will deliver the signal to the receiving location in the same format and condition as generated by the Customer.



Effective: April 1, 2016

---

ADVANCED DATA SERVICES

F. INTEGRATED OPTICAL SERVICES (IOS) (Continued)

6. TERMS AND CONDITIONS (Continued)

d. Service Level Agreements

1) General

The following Service Level Agreements (SLAs) apply only to the IOS network and Riders. The applicable SLAs are Mean Time To Restore and Service Availability. Customer is eligible for Service Response Credits (SRCs) for missed SLAs with respect to the IOS network and Riders (Affected Services). No SLAs shall be available until the Affected Service measured is in service for at least one full calendar month.

In order to obtain an SRC, Customer must make a written request as directed by Frontier for such SRCs within thirty (30) calendar days of the end of the monitoring period for the SLA measurement. The request must include a list of all impacted circuit/connection identification numbers and the type of SRC requested for each circuit/connection. The monitoring period for all SLAs is based on a calendar month. Any SRCs are subject to verification by Frontier through its own monitoring systems and procedures.

For any calendar month, the SRCs may not exceed the total monthly recurring charges (MRCs) billed to Customer for the Affected Service that is subject to a missed SLA for that month.

No SRCs will be issued to the extent the missed SLA is caused by the following:

- a) The negligence of the Customer or a third party authorized by the Customer to use the IOS;
- b) Failure of power, CPE or other equipment, systems, facilities or services not provided by Frontier;
- c) Customer's failure to release any IOS component for testing and/or repair or Frontier is otherwise not afforded access to the premises where the IOS are provided;
- d) The SLA is missed due to routine maintenance of the IOS, an IOS rearrangement requested by Customer, or the implementation of a Customer issued service order for a change to the IOS;
- e) Customer failure to authorize replacement of any element of new construction following the receipt of written notification by Frontier of the need for such replacement;
- f.) Force majeure events;
- g) Subsequent reports made by Customer while the initial trouble report is pending or service troubles repaired by Frontier prior to its receipt of a trouble report; and
- h) Service troubles closed due to Customer action.

---

ADVANCED DATA SERVICES

F. INTEGRATED OPTICAL SERVICES (IOS) (Continued)

6. TERMS AND CONDITIONS (Continued)

d. Service Level Agreements (Continued)

2) Service Availability

The Service Availability SLA refers to the percentage of time during a calendar month that the Affected Services (*i.e.*, IOS network or Riders as may be applicable) is available for use by Customer, which means that the Affected Service is capable of transmitting data over such Affected Service. Measurements for Service Availability shall not be rounded up. Service Availability is calculated based upon the total number of minutes in a calendar month that Customer was actually in service divided by the total number of minutes in such month for all Affected Services.

With respect to IOS network, the Service Availability SLA is 99.999%. If the overall Service Availability measurement for the IOS network is less than that threshold for a calendar month, Customer is eligible for an SRC of twenty-five percent (25%) of the MRCs for Nodes and Mileage.

The Service Availability measurement of a Protected Rider is 99.999%. The Service Availability of an Unprotected Rider is 99.000%. When the Service Availability SLA for a Rider is not met, Customer is eligible for an SRC of twenty-five percent (25%) of the MRCs for the Appearances relating to the Affected Rider that did not meet such threshold during such calendar month.

3) Mean Time to Restore

The Mean Time to Restore (MTTR) SLA refers to the average Time to Restore (TTR) for Customer-reported IOS Interruptions. An IOS Interruption shall mean that data cannot be transported over the IOS network solely because of a failure in Frontier-provided facilities.

The TTR is measured from the date and time a trouble ticket is opened by Frontier and the date and time when such ticket is closed by Frontier. In measuring the TTR, any stop clock time or adjusted duration time basis associated with the trouble shall be subtracted from such measurement. For purposes of this measurement, stop clock time refers to:

- a) time periods when Customer testing is occurring,
- b) time periods when Frontier is awaiting Customer authorization to commence work on the IOS;
- c) periods when the Customer is working on its equipment and has not released the facility to Frontier for maintenance, testing, or repair;
- d) Frontier is denied access to Customer premises or facilities as necessary to diagnose, repair or test;
- e) periods following a repair of a Service when the trouble ticket is held open by Customer to ensure the trouble is resolved;
- f) periods when pre-defined maintenance windows have been established between the Customer and Frontier, and
- g) any time period during which any of the occurrences listed in F.6.d.3)a) - f) preceding existed.

---

ADVANCED DATA SERVICES

F. INTEGRATED OPTICAL SERVICES (IOS) (Continued)

6. TERMS AND CONDITIONS (Continued)

d. Service Level Agreements (Continued)

3) Mean Time to Restore (Continued)

The MTTR SLA shall not apply to cases where no trouble is found, informational tickets, subsequent trouble tickets made by Customer while the initial trouble report is pending or trouble repaired by Frontier prior to its receipt of a trouble ticket.

The MTTR SLA shall be measured on a calendar month basis and shall be calculated by adding the TTR for all IOS Interruptions and dividing that sum by the total number of trouble tickets opened for such Interruptions for that Customer during that month. Calculation of MTTR shall exclude any subsequent reports (additional Customer inquiries while the trouble is pending), and troubles repaired by Frontier prior to receipt of a trouble report on the Affected Service from Customer.

If the MTTR for the IOS network is greater than 2.5 hours over the calendar month, then Customer will be eligible for an SRC of twenty-five percent (25%) of the MRC per Affected Node or Mileage that was interrupted for more than 2.5 hours.

The MTTR for a Service Interruption of a Protected Rider is 2.5 hours. The MTTR for a Service Interruption of an Unprotected Rider is four (4) hours. For a Protected Rider, if the MTTR is greater than 2.5 hours over the calendar month, then Customer will be eligible for an SRC of one hundred percent (100%) of the MRC per Appearance for such Affected Rider that was interrupted for more than 2.5 hours. For an Unprotected Rider, if the MTTR is greater than four (4) hours over the calendar month, then Customer is eligible for an SRC of one hundred percent (100%) of the MRC per Appearance for such Affected Rider that was interrupted for more than four (4) hours.

4) Exceptions

The Remedies set forth in Section F.6.d. 2) and 3) preceding will not apply in the following instances:

- a) Interruptions, failures, or delays in service resulting from DC power, equipment, service, or services not under the sole responsibility of Frontier.
- b) Interruptions, failures, or delays in service resulting from Customer owned and/or installed equipment.
- c) Interruptions, failures, or delays in service that occur at any time in which Frontier or its authorized agents, after reasonable attempt to gain access to the Customer designated premises, are not granted access to such premises where Frontier Facilities and equipment associated with the provision of IOS are terminated.
- d) Interruptions or delays in service resulting from maintenance, rearrangement of service, or implementation of an order authorized by the Customer.

Effective: April 1, 2016

---

ADVANCED DATA SERVICES

F. INTEGRATED OPTICAL SERVICES (IOS) (Continued)

6. TERMS AND CONDITIONS (Continued)

d. Service Level Agreements (Continued)

4) Exceptions (Continued)

- e) Interruptions, failures, or delays in service resulting from the Customer's refusal to release IOS to Frontier or its authorized agents for testing and/or repair, after reasonable attempts by Frontier or its authorized agent to schedule repair with the Customer.
- f) Interruptions, failures, or delays in service due to acts of God or the public enemy, compliance with any order of any governmental authority, acts of terrorism, war, rebellion, insurrection, or sabotage or damage resulting from, fires, floods, earthquakes, unusually severe weather, explosions, washouts, rules and regulations with regard to common carriers, accidents, epidemics, breakdowns, riots, strikes or other concerted acts of its employees, whether direct or indirect, lockouts or other industrial disturbances, whether direct or indirect, worms, viruses or other contaminants that may cause damage to or disable software, computer, or electronic services, or any similar cause, or other causes beyond such party's reasonable control.
- g) Interruptions, failures, or delays in service during periods of scheduled maintenance and scheduled downtimes where the Customer has received prior written (electronic, fax, or paper) notification from Frontier.
- h) Interruptions resulting from the negligence, gross negligence, willful misconduct, or other act or omission of the Customer or other party authorized by the Customer to use the service.

e. Conversions and Upgrades

Customers who wish to convert one (1) or both Points of Termination of an existing High Capacity Special Access services, Special Access DSR, Special Access IOTS, Special Access IBT, or Special Access Custom Connect to IOS may do so without conversion charges (termination liability and installation charges) as long as the total capacity of Special Access services purchased by the Customer does not decrease.

7. APPLICATION OF RATES AND CHARGES

a. Monthly Rates

MRCs apply for the Node, Ring Mileage, and Riders.

The MRC for a Rider applies per appearance, and two (2) appearances apply per Rider for the entire point-to-point (Node-to-Node) connection. MRCs for Riders are also differentiated by whether the Rider is Protected or Unprotected, and whether the Rider is delivered with Drop Port Protection.

---

ADVANCED DATA SERVICES

F. INTEGRATED OPTICAL SERVICES (IOS) (Continued)

7. APPLICATION OF RATES AND CHARGES (Continued)

b. Nonrecurring Charges

A nonrecurring charge (NRC) applies for any subsequent installation of a Node.

Subsequent installations of Nodes include (i) Nodes that are added to an existing ring, and (ii) existing Nodes on the ring that are moved to a new location and remain on that same ring. Nodes that are moved to a new location and remain on the same ring are also subject to the requirements set forth in Section F.7.c. following.

A Consultation and Support charge applies for each thirty (30) minutes or fraction thereof that the Customer requests Frontier consultation and support of its CSM network. This charge does not apply during initial setup of CSM.

First and additional nonrecurring charges apply for the installation of EPRS UNIs provided on a month-to-month basis.

Any other required work, services or facilities not referred to herein will be provided subject to prevailing rates and charges, as set forth in Frontier's Product Guide or other tariffs, or, as mutually agreed to in writing by the parties.

c. Term Plans

IOS is available for term plans of 1 year, 2 years, 3 years, 5 years, or 7 years (Commitment Periods) for the Nodes, Ring Mileage, and Riders. IOS is also available with a 3-, 5-, or 7-year Commitment Period for EPRS. EPRS UNIs and certain Riders are also available on month-to-month basis. However, such Riders shall have a 12 month minimum service period. As such, if a month-to-month Rider is terminated prior to the first twelve months following installation of such Rider, the Customer will be responsible for termination liability of 100% of the monthly rates for the Rider times the number of months left in such twelve month period.

Nodes, Riders, and EPRS UNIs added subsequent to the initial installation and prior to the first twelve (12) months of a 2-year term plan, the first twenty-one (21) months of a 3-year term plan, the first thirty-six (36) months of a 5-year term plan, or the first fifty (50) months of a 7-year term plan will be added to the existing term plan with an expiration date that is coterminous with the expiration date for the remainder of the service. For example, a Node added in the 18th month of a 3-year term plan will be added to the existing term plan for the balance of the 3-year Commitment Period. The rate applicable to such Node is the 3-year rate for the applicable Rider. Nodes added to an IOS on a 1-year term plan require a 1-year extension beyond the completion of the current 1-year term plan.

Nodes, Riders, and EPRS UNIs added subsequent to the initial installation and after the first 12 months of a 2-year term plan, the first 21 months of a 3-year term plan, the first 36 months of a 5-year term plan, or the first 50 months of a 7-year term plan require that the existing term plan be extended so that the term plan will include the existing services and the added services. In doing so, the expiration date of the existing services and the added services will be common (coterminous) for all rate elements of the service. The existing term plan shall be extended by 12 months for a 2-year term plan, 12 months for a 3-year term plan, 24 months for a 5-year term plan, or 36 months for a 7-year term plan. For example, a Node added in the 38th month of a 5-year term plan requires that the expiration date for the 5-year term plan be extended by 24 months so that the existing rate elements (e.g., Nodes, Riders, etc) and the added Node will have a coterminous expiration date.

Effective: April 1, 2016

---

ADVANCED DATA SERVICES

F. INTEGRATED OPTICAL SERVICES (IOS) (Continued)

7. APPLICATION OF RATES AND CHARGES (Continued)

c. Term Plans (Continued)

EPRS UNIs provided on a month-to-month basis may be added at any time. Changes in month-to-month billed EPRS UNIs are treated as disconnects and subsequent installations.

Riders (appearances) provided on a month-to-month basis may be added at any time subsequent to the initial installation of IOS. Such Riders will be added for the balance of the applicable Commitment Period and do not require extension of the term plan as specified in Section F.7.d. following. Riders are described in Section F.4.a.3) preceding.

d. Extension and Renewal of Commitment Period

Once a term period expires, the prevailing rates of the current term plan will continue until the Customer cancels service, extends the term plan, or requests a new term plan.

When the Commitment Period for IOS is extended under this Section 7.d., termination liability is calculated as the difference between the monthly rates for the highest term plan Commitment Period that could have been satisfied prior to disconnection of the service or cancellation of the plan and the monthly rates already paid for the expired Commitment Period and the extended Commitment Period for the period of time the service was in effect. For example: If a customer is on a 3-year plan and extends to a 5-year plan, and terminates the service in month 48, the termination liability will be the difference between the 3-year Node and Mileage MRC and 5-year Node and Mileage MRC multiplied by 12 months (for months 37 through 48).

The Customer has the option to extend its expiring term plan to a plan with a longer Commitment Period, for which the original term will be considered under the new extended term. For example, an expiring 3-year term plan will allow for 3 years towards the extended plan. The Commitment Period selected for the extended plan must be longer than the Commitment Period of the expiring plan as follows:

- An expiring 1-year term plan may be extended to a 2-year, 3-year, 5-year, or 7-year term plan.
- An expiring 2-year term plan may be extended to a 3-year, 5-year, or 7-year term plan.
- An expiring 3-year term plan may be extended to a 5-year or 7-year term plan.
- An expiring 5-year term plan may be extended to a 7-year term plan.

The Customer may also extend the Commitment Period in order to install additional Nodes or Riders as described in Section F.7.c. preceding.

The rate for the longer Commitment Period will apply effective with the first bill day following expiration of the Commitment Period for the existing plan and continue through the remainder of the Commitment Period associated with the extended plan. No adjustment for the increased discount associated with the extended plan will be made to the monthly rates already billed on the expiring plan.

---

ADVANCED DATA SERVICES

F. INTEGRATED OPTICAL SERVICES (IOS) (Continued)

7. APPLICATION OF RATES AND CHARGES (Continued)

e. Moves and Changes

1) Node Moves

The Customer may move a Node subject to all of the following:

- a) The Node must remain on the same ring.
- b) The Customer remains responsible for any outstanding minimum period obligations on the Node being disconnected from its originally installed location.
- c) A new minimum period will be established for the Node at the newly installed location.
- d) The newly installed Node will be treated as a Node addition in accordance with Section F.7.b. preceding.
- e) A subsequent installation charge applies for installation of the Node at the new location.

When the above requirements are met, termination liability will not apply for discontinuance of the Node from its originally installed location. In all other cases, termination liability applies for discontinuance of the Node from its originally installed location.

2) Change in Rider

A change in the type (e.g., Fibre Channel to Gigabit Ethernet) of a Rider is treated as a discontinuance of the existing Rider and an installation of a new Rider. Termination liability does not apply to a Rider that is changed to another Rider of the same bandwidth.

A change of a Rider to a new Rider with a higher optical carrier rate (e.g., OC3 to OC12) is an upgrade for which termination liability charges do not apply to the Rider being disconnected.

Minimum period obligations apply for both of the changes in Riders described above.

---

ADVANCED DATA SERVICES

F. INTEGRATED OPTICAL SERVICES (IOS) (Continued)

7. APPLICATION OF RATES AND CHARGES (Continued)

f. Order Cancellation

A Customer may cancel an order for the installation of IOS at any time prior to notification by Frontier that service is available for the Customer's use or prior to the Service Date, whichever is later. The cancellation date is the date Frontier receives written or verbal notice from the Customer that the order is to be cancelled. The verbal notice must be followed by written confirmation within ten (10) days.

Cancellation charges apply if the Customer cancels an order, or part of an order, for the installation of Integrated Optical Service, or to partition the ring for EPRS, after providing Frontier with written or electronic notification to begin installation. Cancellation charges apply as follows:

1. When a Customer cancels the order, or part of the order, within the first thirty (30) days following written or electronic notification to Frontier to begin installation, no cancellation charge will apply.
2. When a Customer cancels the order, or part of the order, on the thirty-first (31st) day, but no later than the sixtieth (60th) day, following written or electronic notification to Frontier to begin installation, cancellation charges will apply.
3. When a Customer cancels the order, or part of the order, on the sixty-first (61st) day following written or electronic notification to Frontier to begin installation, up to the date of notification that installation is complete, cancellation charges will apply.
4. If the Customer cancels the order, or part of the order, after installation is complete, cancellation will apply. Minimum period charges as described in Section F.7.h. following and termination liability as described in Section F.7.g. following will also apply.
5. When a Customer cancels the order, or part of the order, to establish an EPRS partition on its Integrated Optical Service, cancellation charges apply.



---

ADVANCED DATA SERVICES

F. INTEGRATED OPTICAL SERVICES (IOS) (Continued)

7. APPLICATION OF RATES AND CHARGES (Continued)

g. Termination Liability

Termination liability applies to IOS and is charged per monthly rate element on all Nodes, Riders (Appearances), and EPRS.

Termination liability does not apply to Ring Mileage.

A separate termination liability charge is assessed for each rate element associated with the disconnected IOS.

Termination liability is calculated as follows:

- 1) If the disconnection occurs during the first year of the Commitment Period, the Minimum Period obligation specified in Section F.7.h. following applies for the unexpired portion of the first year. Termination liability is calculated at one hundred percent (100%) of the MRCs for the second year and twenty-five percent (25%) of the MRCs for the 25th month through the remainder of the Commitment Period, as applicable.
- 2) If the disconnection occurs during the second year of the Commitment Period, termination liability is calculated at one hundred percent (100%) of the MRCs for the unexpired portion of the second year and twenty-five percent (25%) of the MRCs for the 25th month through the remainder of the Commitment Period, as applicable.
- 3) If the disconnection occurs after the first two (2) years of the Commitment Period, termination liability is calculated at twenty-five (25%) of the MRCs from the date of disconnection through the remainder of the Commitment Period.

IBT, Special Access DS1 and DS3 High Capacity Service, and Frontier Optical Networking services associated with IOS are subject to the termination liability specified for such service pursuant to the applicable arrangement offered by Frontier.

h. Minimum Period

The minimum period for which IOS (i.e. Nodes, Mileage and Riders) is provided is twelve (12) months, regardless of the applicable term plan requested.

When an IOS term plan is disconnected prior to the expiration of the minimum period, minimum period charges are applicable for the balance of the minimum period. The charge for each month, or fraction thereof, remaining in the minimum period is the applicable monthly rate for the service.

Riders must be purchased for a minimum period of twelve (12) months following installation of such Riders. Off-Net Riders may also be purchased for longer service periods of twenty-four (24), thirty-six (36) or sixty (60) months.

Effective: April 1, 2016

---

ADVANCED DATA SERVICES

F. INTEGRATED OPTICAL SERVICES (IOS) (Continued)

8. RATES AND CHARGES

a. IOS Nodes, per node

	<u>Monthly Rate</u>	
Month to month	N/A	
1-Year Term	\$14,000.00	
2-Year Term	11,000.00	
3-Year Term	8,800.00	
5-Year Term	7,500.00	
7-Year Term	7,000.00	
		<u>Nonrecurring Charge</u>
Subsequent Node Installation Charge		\$5,000.00

b. IOS Mileage, per mile

	<u>Monthly Rate</u>
Month to month	N/A
1-Year Term	\$625.00
2-Year Term	500.00
3-Year Term	400.00
5-Year Term	350.00
7-Year Term	325.00



Effective: April 1, 2016

ADVANCED DATA SERVICES

F. INTEGRATED OPTICAL SERVICES (IOS) (Continued)

8. RATES AND CHARGES (Continued)

d. Unprotected Riders

Two Appearances per Rider provided on a Node-to-Node (i.e., point-to-point) basis

<u>Appearance Type</u>	<u>Month-to-Month</u>	<u>Monthly Rate</u>				
		<u>1-Year Term</u>	<u>2-Year Term</u>	<u>3-Year Term</u>	<u>5-Year Term</u>	<u>7-Year Term</u>
SONET OC48/48c	\$650.00	\$650.00	\$650.00	\$650.00	\$650.00	\$650.00
SONET OC192/192c	1,225.00	1,225.00	1,225.00	1,225.00	1,225.00	1,225.00
1 Gbps Fibre Channel	625.00	625.00	625.00	625.00	625.00	625.00
2 Gbps Fibre Channel	825.00	825.00	825.00	825.00	825.00	825.00
4 Gbps Fibre Channel	1,025.00	1,025.00	1,025.00	1,025.00	1,025.00	1,025.00
10 Gbps Fibre Channel	1,225.00	1,225.00	1,225.00	1,225.00	1,225.00	1,225.00
Gigabit Ethernet @ 1000Mbps	625.00	625.00	625.00	625.00	625.00	625.00
10Gbps Ethernet (LAN-PHY/WAN-PHY)	1,225.00	1,225.00	1,225.00	1,225.00	1,225.00	1,225.00

	<u>Nonrecurring Charge</u>
e. <u>Consultation and Support</u> , each 30 minutes or fraction thereof	\$100.00

Effective: April 1, 2016

---

ADVANCED DATA SERVICES

G. SPECIALIZED FIA OR ARRANGEMENTS

1. GENERAL

Specialized FIA or Arrangements may be provided by the Utility at the request of a customer, on an Individual Case Basis (ICB) if such FIA or arrangements meet the following criteria:

- a. The requested FIA or arrangements are not offered under other sections of this Product Guide.
- b. The facilities utilized to provide the requested FIA or arrangements are of a type normally used by the Utility in furnishing its other services.
- c. The requested FIA or arrangements are provided within a Market Area.
- d. The requested FIA or arrangements are compatible with other Utility services, facilities, and its engineering and maintenance practices.

This offering is subject to the availability of the necessary Utility personnel and capital resources.

2. RATES AND CHARGES

Rates and charges and additional regulations, if applicable, for Specialized FIA or Arrangements provided on an individual case basis will be filed herein.

Effective: April 1, 2016

---

ADVANCED DATA SERVICES

H. SPECIAL FACILITIES ROUTING OF FIA

1. DESCRIPTION

The FIA are provided over such routes and facilities as the Utility may elect. Special routing is involved where, in order to comply with requirements specified by the customer, the Utility provides Access Services in a manner which includes one or more of the following conditions.

a. Diversity

Where two or more FIA must be provided over not more than two different physical routes.

b. Avoidance

Where a FIA must be provided on a route which avoids specified geographical locations.

c. Cable-Only Facilities

Where certain voice grade FIA are provided on cable-only facilities to meet the particular needs of a customer. FIA is provided subject to the availability of cable-only facilities. In the event of FIA failure, restoration will be made through the use of any available facilities as selected by the Utility.

In order to identify any special routing requirement, the Utility will provide the ordering customer with the required routing information for each specially routed FIA. If requested by the customer, this information will be provided when the FIA is installed and prior to any subsequent change in routing.

The rates and charges for Special Facilities Routing of FIA are in addition to all other rates and charges.

2. RATES AND CHARGES

The rates and charges for Special Facilities Routing of FIA will be developed on an individual case basis for Diversity, Avoidance, Diversity and Avoidance Combined and Cable-Only Facilities.

---

ADVANCED DATA SERVICES

I. SPECIAL FEDERAL GOVERNMENT FIA

1. GENERAL

This section covers FIA that are provided for use only by agencies or branches of the Federal Government and other users authorized by the Federal Government. FIA provided to state emergency operations centers are included. These FIA provide for command and control communications, including communications for national security, emergency preparedness and presidential requirements. They are required to assure continuity of Government in emergency and crisis situations and to provide for national security.

FIA for command and control communications and for national security and emergency preparedness sometimes required within a short time frame. These provisions are especially needed to meet presidential requirements or in response to natural, man-made, or declared emergencies. Requirements of this type cannot be forecasted and are usually needed for a relatively short period. The provision of FIA under these conditions may require the availability of facilities, such as portable microwave equipment, etc., which are provided on a temporary basis.

2. EMERGENCY CONDITIONS

These FIA will be provided on the date requested or as soon as possible thereafter when the emergency falls into one of the following categories:

- a. State of crisis declared by the National Command Authorities (includes commitments made to the National Communications System in the "National Plan for Emergencies and Major Disasters").
- b. Efforts to protect endangered U.S. personnel or property both in the U.S. and abroad (includes space vehicle recovery and protection efforts).
- c. Communications requirements resulting from hostile action, a major disaster or a major civil disturbance.
- d. The Director (Cabinet level) of a Federal Department, Commander of a Unified/Specified Command, or Head of a Military Department has certified that a communications requirements is so critical to the protection of life and processed immediately.
- e. Political unrest in foreign countries which affect the national interest.
- f. Presidential Service

3. INTERVALS TO PROVIDE FIA

Orders for FIA may be placed under the provisions, as set forth under Ordering Options for FIA.

---

ADVANCED DATA SERVICES

I. SPECIAL FEDERAL GOVERNMENT FIA (Continued)

4. SAFEGUARDING OF FIA

a. FIA Availability

In order to insure communications during periods of emergency, the Utility will (within the limits of good management) make available the necessary facilities to restore FIA in the event of damage or to provide temporary emergency FIA.

In order to meet the requirements of agencies or branches of the Federal Government, the Utility may utilize Government owned facilities, when necessary, to provide FIA.

5. FEDERAL GOVERNMENT REGULATIONS

FIA provided to the Federal Government will be billed in arrears, as required by Federal procurement or disbursement regulations or as established by law. ICs providing service to Federal Government are not entitled to the benefits of those laws or regulations providing for billing the Federal Government in arrears.

6. FIA OFFERINGS TO THE FEDERAL GOVERNMENT

The following FIA are provided to a customer only for agencies or branches of the Federal Government. Access Services provided to the Federal Government, but not specified in the following, will be provided In accordance with the regulations and rates set forth in other sections of this Product Guide.

a. Type and Description

1. Voiceband Special Access

(a) Voice Grade Secure Communications Type I

Approximate bandwidth of 10 to 50,000 Hz. Furnished for two-point secure communications on two-wire or four-wire metallic facilities between a point of presence and an end user premises. For conditioning provisions, refer to Frontier Operating Companies Tariff FCC No. 14.

(b) Voice Grade Secure Communications Type II

Approximate bandwidth 10-50,000 Hz. Furnished on four-wire metallic facilities for duplex operation for two-point secure communication between a point of presence and an end user's premises. For conditioning provisions, refer to Frontier Operating Companies Tariff FCC No. 14.

(c) Voice Grade Secure Communications Type III

Approximate bandwidth 10-50,000 Hz. Furnished on four-wire metallic facilities for two-point secure communication between a point of presence and an end user's premises. For conditioning provisions, refer to Frontier Operating Companies Tariff FCC No. 14.

(d) Voice Grade Secure Communications Type IV

Approximate bandwidth 10 to 50,000 Hz. Furnished on four-wire metallic facilities for duplex operations for two-point secure communications between two points of presence. For conditioning provisions, refer to Frontier Operating Companies Tariff FCC No. 14.



---

ADVANCED DATA SERVICES

I. SPECIAL FEDERAL GOVERNMENT FIA (Continued)

6. FIA OFFERINGS TO THE FEDERAL GOVERNMENT (Continued)

a. Type and Description (Continued)

2. Special Wideband Digital Special Access

Special Access arrangements for secured communications to accommodate the transmission of binary digital baseband signals in a random polar format.

(a) Wideband Secure Communications Type I

For transmission at the rate of 18,750 bits per second.

(b) Wideband Secure Communications Type II

For transmission at the rate of 50,000 bits per second.

(c) Wideband Secure Communications Type III

To accommodate the transmission of restored polar two-level facsimile signals with a minimum signal element width of 20 microseconds at a rate of 50,000 bits per second.

To accommodate the transmission of binary digital baseband signals in a random polar format at the rate of 50,000 bits per second.

b. Mileage Application

Mileage for rate application is the airline distance measured between the two related Special Access terminating points (i.e., point of presence and end user premises).

ADVANCED DATA SERVICES

I. SPECIAL FEDERAL GOVERNMENT FIA (Continued)

6. FIA OFFERINGS TO THE FEDERAL GOVERNMENT (Continued)

c. Rates and Charges

1. Voiceband Special Access

The provision of T-3 and G conditioned Special Access contemplates station and tandem switching operations using customer provided equipment, as well as Special Access. Separate Narrowband or dice Grade Special Access, where required by the customer provided equipment or switching operation, are furnished in accordance with the applicable sections of this Product Guide.

<u>Voiceband Secure Communications</u>	<u>Monthly Rates</u>	<u>Nonrecurring Charges</u>	<u>Termination Charges</u>
Type I, each T-3 Conditioning	ICB rates and charges apply		
Additional Conditioning, per Special Access termination	ICB rates and charges apply		
Type II, each G-1 Conditioning	ICB rates and charges apply		
Type III, each G-2 Conditioning	ICB rates and charges apply		
Additional Conditioning, per Special Access termination	ICB rates and charges apply		
Type IV, each G-3 Conditioning	ICB rates and charges apply		
Additional Conditioning, per Special Access termination	ICB rates and charges apply		

2. Special Wideband Digital Special Access

Wideband Secure Communications

Type I, each	ICB rates and charges apply
Type II, each	ICB rates and charges apply
Type III, each	ICB rates and charges apply

Effective: April 1, 2016

---

ADVANCED DATA SERVICES

I. SPECIAL FEDERAL GOVERNMENT FIA (Continued)

6. FIA OFFERINGS TO THE FEDERAL GOVERNMENT (Continued)

d. Move Charges

When Special Access service requiring T-3 conditioning, T-3 additional conditioning, or a Special Access requiring G conditioning is moved to a different premises or to a different building, the full nonrecurring charge applies; when moved to a new location on the same premises, a charge of one half the nonrecurring charge applies.

When any FIA for which a termination charge is specified is moved and is installed at a new location the customer may elect:

- (1) to pay the unexpired portion of the termination charge for the FIA, if any, with the application of a nonrecurring charge and the establishment of a new termination charge for such FIA at the new location;  
or
- (2) to continue the FIA subject to the unexpired portion of the termination charge, if any, and pay the estimated costs of moving such FIA, provided that the customer requests these charges be quoted prior to ordering the FIA move. Charges for moving such FIA will be based on estimated costs attributable to the move.

Move charges include the estimated costs of removal, restoration of FIA necessitated by the move, transportation, storage, reinstallation, engineering, labor, supervision, materials, administration, taxes, and any other specific items of cost directly attributable to the move.

---

## ADVANCED DATA SERVICES

### J. TRANSPARENT LAN SERVICE (TLS)

#### 1. DEFINITIONS

Domain - Closed User Groups, also known as Virtual LANs (VLANs), which are used to provide traffic separation, privacy and security between customers on the shared switch and backbone. Users in a group can only access their own data.

Gigabit Per Second (Gbps): Data transfer rate for 1000 Mbps. The speed at which data is transferred through the network, where one Gigabit per second equals the transfer rate of one (1) billion bits of data in one (1) second.

Megabit Per Second (Mbps.) - The speed where data is being transferred in the network, where one Megabit Per Second equals to the transfer rate of 1 million bits of data in 1 second.

Nanometers (nm) - Wavelength frequency equivalent to 1 billionth of a meter.

#### 2. SERVICE DESCRIPTION

Transparent LAN Service (TLS) is a high speed data service which uses a shared fiber network to allow for the interconnection of Local Area Networks (LANs) across selected metropolitan areas in the same Local Access Transport Area (LATA). TLS delivers high speed data service to the interface at speeds of 10 Mbps, 100 Mbps, 1000 Mbps and 10 Gbps from the customer's LANs to the shared network.

TLS creates a network with the ability to function as a shared public network. TLS protects data privacy by using specialized screening software that permits subscribers to access only their data.

TLS is available as two service types: Ethernet Multipoint Service (EMS) or Ethernet Relay Service (ERS). The customer must select either EMS or ERS as the service type for each domain:

Ethernet Multipoint Service (EMS) is a connection-less Ethernet TLS service that allows connectivity among multiple customer designated locations within a LATA.

With the EMS service type, Ethernet TLS protects data privacy by using closed user groups (CUGs), also known as virtual LANs. CUGs or virtual LANs are used to provide traffic separation, privacy and security between customers on the shared switch and backbone. An EMS domain is comprised of any number of access lines designated by the customer to be included in a closed user group (CUG) or virtual LAN. EMS provides multipoint-to-multipoint connectivity among all of the customer's access lines within a given domain.

TLS may be used to access shared networks. In such cases, subscribers in a CUG can only access their own data.

---

ADVANCED DATA SERVICES

J. TRANSPARENT LAN SERVICE (TLS) (Continued)

2. SERVICE DESCRIPTION (Continued)

Ethernet Relay Service (ERS) is a connection-oriented Ethernet TLS service that allows for point-to-point connectivity between customer designated locations within a LATA.

With the ERS service type, each Ethernet Virtual Circuit (EVC) establishes a virtual LAN or CUG. An ERS domain is comprised of any number of virtual LANs designated by the customer to be included in the ERS domain. ERS provides point-to-point connectivity between pairs of customer's access lines and shared, Internet virtual circuits, and shared network services within a given domain.

A customer may have more than one domain within a LATA, but connections between domains are not permitted. TLS may be used to access shared networks. In such cases, subscribers in a CUG can only access their own data.

With ERS service type, an Ethernet Virtual Private – Local Area Network (EVP -LAN) can be established with EVP-LAN EVCs. An EVP-LAN is a multipoint Virtual LAN comprised of a CUG of two or more EVCs. EVP-LAN EVCs are designated by the Customer within an ERS Premier domain.

Six EVC service classes are available for use with the ERS service type:

ERS Standard (ERS-Std) and ERS Basic (ERS-B) and EVP-LAN Basic (EVPLAN-B) are designed for customer applications that do not require a Committed Information Rate (CIR) or low delay, where CIR = 0 and Excess Information Rate (EIR) = # of Mbps of the selected ERS-Std/ERS-B or EVPLAN-B EVC service class.

ERS-Priority Data (ERS-PD) is designed for customer applications which do not require low delay, but require a CIR, where CIR = # of Mbps of the selected ERS-PD EVC service class and EIR = # of Mbps of the selected ERS-PD EVC service class.

ERS Real Time (ERS-RT) and EVP-LAN Real Time (EVPLAN-RT) are designed for customer applications which require a CIR and low delay for some portion of their traffic, where CIR = # of Mbps of the selected ERS-RT or EVPLAN-RT EVC service class and EIR = 0. EVPLAN-RT is not available for 10 Gbps UNI Speed.

An ERS EVC can include up to three service classes (ERS-B, ERS-PD and ERS-RT) as described above within each EVC. An EVP-LAN EVC can include one service class (either EVPLAN-B or EVPLAN-RT) as described above within each EVC. The customer will be required to identify the B, PD and RT Class of Service Ethernet frames by one of the following choices, as appropriate:

- setting the VLAN Class of Service (CoS) ID ( for 802.1q tagged Ethernet Frames); or
- setting the DiffServ Code Point (DSCP) (for tagged or untagged Ethernet frames); or
- setting the VLAN ID (for tagged or untagged Ethernet frames).

---

ADVANCED DATA SERVICES

J. TRANSPARENT LAN SERVICE (TLS) (Continued)

3. SPECIAL CONDITIONS

- (a) A TLS network will be limited to central offices in a specific geographic location. Customers gain access to the shared TLS network via a switch, node or other Utility equipment delivering service through a shared fiber path or network infra-structure and deployed in the customer's serving central office (TLS equipped central office) deployed in leased space near the Customer's location or deployed at the Customer's location. At subscription, the Customer has an option of selecting access lines at speeds of 10 Mbps, 100 Mbps, 1000 Mbps, or 10 Gbps.
- (b) TLS is available to customers whose serving central office is a TLS equipped central office and is located within the maximum allowable range of the serving central office. The maximum allowable fiber range is determined by the dB loss rate where the actual distance between the TLS equipped serving wire center and the customer's location will vary based on the specifics of the facility used in each serving arrangement.
- (c) If the customer's serving central office is not a TLS equipped central office, the Customer may obtain service by paying the Interoffice Mileage charge in addition to TLS access charges. The dB loss cannot exceed the maximum allowable range, as specified in F.3.(b) above.

For standard 'unprotected' UNI Port and Access connectivity at bandwidths of 10Mbps, 100Mbps and 1000Mbps, the first twenty Interoffice miles are included in the monthly recurring charge (MRC) of the UNI Port and Access. Interoffice mileage charges will apply to any IOF mileage that exceeds twenty miles per UNI. For UNI Port and Access at a bandwidth of 10Gbps, Customer shall be subject to all applicable IOF mileage charges, including the first twenty miles.

- (d) The standard Customer connectivity model for UNI Port and Access includes direct fiber or existing transport facilities between the Customer's location and the TLS equipped central office. Customers requesting Protected Access Line service will have two standby fibers provisioned in addition to the primary direct fiber. Customer may select to have their UNI Port and Access provisioned over an optical transport system. If so, the customer must choose one of the following UNI Port with Access arrangements:
  - Protected Non-Diverse: Customer connectivity is provisioned over an optical transport system as a survivable service with an alternate (non diverse) facility between the Customer's location and the TLS equipped central office. The optical protected interoffice charge is applicable to 1000 Mbps speed when interoffice facilities are required.
  - Protected Diverse: Customer connectivity is provisioned over an optical transport system as a survivable service with an alternate and diverse fiber path between the Customer's location and the TLS equipped central office. The optical protected interoffice charge is applicable to 1000 Mbps speed when interoffice facilities are required. Dual entrance at the customer premises and company wire centers are not considered a standard feature of this option, but may be provided through special construction charges, where facilities are available.
  - Protected Private: Customer connectivity is provisioned over a dedicated private ring which the customer has already obtained from the Telephone Company. At least one node of the private ring must be located in a TLS equipped central office.

Effective: April 1, 2016

---

ADVANCED DATA SERVICES

J. TRANSPARENT LAN SERVICE (TLS) (Continued)

3. SPECIAL CONDITIONS (Continued)

(e) Provision of Service

TLS service consists of the following components:

- Network Interface Device (NID) at the customer's premises to terminate the fiber pair, or other optical transport.
- Optical transport from the customer's premises to the serving central office.
- Network management including fault monitoring and diagnostics, performance and network configuration applications and manual monitoring when necessary.
- User Network Interface (UNI) Port With Access Line Connection.
- Ethernet Virtual Circuit (EVC), where applicable.
- Interoffice mileage, where applicable.
- Optional Features
- Customer Service Management (CSM) <sup>1</sup>
- Dedicated port on the switch.

(f) Availability of Service

TLS will be provided seven days a week, 24 hours a day, from central offices equipped to provide this service.

ERS Service, including Premier Access Lines and ERS-Std, ERS-B, ERS-PD, ERS-RT, EVPLAN-B AND EVPLAN-RT EVCs, as defined in F.2, will only be available from Central Offices equipped to support ERS service.

(g) Connections

The network interface device (NID) is the LAN interface on the TLS equipment at the customer's premises. The customer is responsible for any inside wire required to connect the LAN to the TLS equipment. The interfaces are as follows: 10 Mbps Ethernet RJ45, 100 Mbps Ethernet RJ45, 1000 Mbps or 10,000 Mbps Ethernet multi-mode optical Connector.

The customer is also responsible for the installation, operation and maintenance of any customer-provided equipment.

The Utility has the service responsibility up to and including the network interface device (NID).

(h) Limitations

The customer's location must be within the maximum allowable range of the TLS equipped central office, as defined in 3.(2) preceding.

<sup>1</sup> Effective February 7, 2011 CSM is no longer available to new Customers. Moves, additions or changes to subscribers' existing service will not be permitted.

Effective: April 1, 2016

---

ADVANCED DATA SERVICES

J. TRANSPARENT LAN SERVICE (TLS) (Continued)

3. SPECIAL CONDITIONS (Continued)

(i) Maintenance Window

To meet the customers' requirements, occasional network upgrades must be performed. These network upgrades are needed to provide improved performance and new features. Generally these upgrades will be performed between the hours of 11:00 PM and 6:00 AM. When network upgrades are planned, Frontier will attempt to provide customers reasonable and timely notification in order to minimize any impact on the customers' service.

(j) Technical Specifications

The technical specifications for TLS are delineated in IEEE802.3-2000.

(k) Transmission Mode

The transmission mode supported is dependent on the access rate, also known as the interface. The supported transmission mode for 10 Mbps access, is half duplex and full duplex. Full duplex 10 Mbps access is available only where conditions and facilities permit. The supported transmission mode for 100 Mbps access, 1000 Mbps or 10 Gbps access is full duplex.

(l) TLS is available where facilities and conditions permit. In the event facilities are not available, special construction charges as specified in the Frontier Product Guide, Section 3, may apply.

4. APPLICATION OF RATES AND CHARGES

(a) The following rate elements are applicable to TLS:

- UNI Port with Access Line Connection
- Ethernet Virtual Circuit (EVC)
- Interoffice Mileage
- Domain/LAN Extension Equipment Changes
- Optional Features
- Customer Service Management (CSM) <sup>1</sup>

<sup>1</sup> Effective May 29, 2012 CSM is no longer available to new Customers. Moves, additions or changes to subscribers' existing service will not be permitted.



Effective: April 1, 2016

---

ADVANCED DATA SERVICES

J. TRANSPARENT LAN SERVICE (TLS) (Continued)

4. APPLICATION OF RATES AND CHARGES (Continued)

(a) The following rate elements are applicable to TLS: (Continued)

(1) UNI Port with Access Line Connection

(i) Standard Access Line (available for EMS or ERS Service Type)

A monthly rate applies on a per line basis, based on the speed of the access connection (i.e., 10 MBPS, 100 MBPS, 1000 MBPS, or 10 Gbps). The Standard Access Line is offered on a Month-to-Month basis, or as a 3 or 5 Year Term Commitment Plan. A nonrecurring charge applies to the installation of Standard Access Lines provided on a Month-to-Month basis.

Besides the standard connectivity model, Standard Access Lines is offered with three other type of UNI Port with Access Line Connections, where facilities exist. (10 Gbps is not available for these Protected options.)

- Protected Non-Diverse
- Protected Diverse
- Protected Private

(ii) Protected Access Line (available for EMS Service Type only) <sup>1</sup>

Protected Access Lines are provisioned as a survivable service with an alternate fiber pair between the central office and the customer premises. Protected Access Line allows the Utility, in most situations, to detect and recover a failure and move the customer's data to an alternate fiber pair in approximately one second in most instances. Both fiber pairs must be served by the same central office and must have the same access speed. The second fiber pair will be routed over a diverse fiber path when possible.

A monthly rate applies on a per line basis, based on the speed of the access connection (i.e., 10 Mbps, 100 Mbps, 1000 Mbps). The Protected Access Line is offered as a Month-to-Month Option, or as a 3- or 5- Year Term Commitment Plan. Protected Access Line is only offered with a direct fiber UNI Port with Access Line Connection, where facilities exist. A nonrecurring charge will apply to the installation of a Protected Access Line provided on a Month-to-Month basis.

<sup>1</sup> Effective November 19, 2010, this service will no longer be available to new customers.

Effective: April 1, 2016

---

ADVANCED DATA SERVICES

J. TRANSPARENT LAN SERVICE (TLS) (Continued)

4. APPLICATION OF RATES AND CHARGES (Continued)

(a) The following rate elements are applicable to TLS: (Continued)

(1) UNI Port with Access Line Connection (Continued)

(iii) Premier Access Line (available for ERS Service Type only)

A monthly rate applies on a per -line basis, based on the speed of the access line (i.e., 10Mbps, 100 Mbps, 1000 Mbps). A Premier Access Line must be purchased in conjunction with some combination of ERS-B, ERS-PD, and/or ERS-RT, EVPLAN-B and/or EVPLAN-RT EVC service classes, which are described in F.2. preceding. The Premier Access Line is offered on a Month-to-Month basis or as a 3- or 5- Year Term Commitment Plan. A nonrecurring charge applies to the installation of the Premier Access Line provided on a Month-to-Month basis. A customer cannot mix Premier UNI Ports with any other UNI Port type.

The percentage of each Premier Access Line UNIs allowed for EVC bandwidth is limited, where connections must comply with each of the following threshold requirements:

ERS-B less than or = to 500% of UNI speed  
ERS-PD less than or = to 100% of UNI speed  
ERS-RT less than or = to 100% of UNI speed  
ERS-PD + ERS-RT less than or = to 100% of UNI speed  
ERS-B + ERS-PD + ERS-RT less than or = to 500% of UNI speed  
EVPLAN-B less than or = 20 Gbps of the EVP-LAN CUG  
EVPLAN-RT less than or = 1 Gbps of the EVP-LAN CUG

Besides the standard connectivity model, Premier Access Line is offered with three other type of UNI Port with Access Line Connections, where facilities exist.

- (1) Protected Non-Diverse
- (2) Protected Diverse
- (3) Protected Private

Effective: April 1, 2016

---

ADVANCED DATA SERVICES

J. TRANSPARENT LAN SERVICE (TLS) (Continued)

4. APPLICATION OF RATES AND CHARGES (Continued)

(a) The following rate elements are applicable to TLS: (Continued)

(1) UNI Port with Access Line Connection

(iv) EMS Real Time (EMS-RT) Access Line (available for EMS Service Type only)

A monthly rate applies on a per-line basis, based on the speed of the access connection (i.e., 100 Mbps, 1000 Mbps, or 10 Gbps). This enhanced service class configures a fixed portion of the UNI for Real Time Traffic, where each 100 Mbps UNI has CIR = 5 Mbps with EIR = 0, or each 1000 Mbps UNI has CIR = 20 Mbps with EIR = 0, and with each 10 Gbps UNI has CIR = 50Mbps with EIR = 0. The remainder of the UNI can be used for CIR = 0 and EIR = 0 traffic. The EMS-RT Access Line is offered on a Month-to-Month basis or as a 3- or 5- Year Term Commitment Plan. A nonrecurring charge applies to the installation of the EMS-RT provided on a Month-to-Month basis. A customer cannot mix an EMS-RT Access Line with the ERS Service type, but may mix EMS-RT Access Line with EMS Access Lines.

Besides the standard connectivity model, Premier Access Line is offered with three other type of UNI Port with Access Line Connections, where facilities exist. (10 Gbps is not available for these Protected options.)

- (1) Protected Non-Diverse
- (2) Protected Diverse
- (3) Protected Private

(2) Ethernet Virtual Circuit (EVC)

For customers who order the ERS Service Type with a Standard Access Line, a monthly rate will apply on a per EVC bandwidth basis. ERS-Std is the only EVC class available with the ERS Standard Access Line. The EVC bandwidth must be equal to the bandwidth of the lowest speed of the end points it is connecting. ERS-Std EVCs are purchased on a Month-to-Month basis. A nonrecurring setup charge will apply per ERS-Std EVC.

For customers who order the Premier Access Line, a monthly rate will apply on a service class and EVC bandwidth basis. Premier Access Line customers have the choice of combining ERS-B, ERS -PD, and/or ERS-RT bandwidth or combining EVPLAN-Basic and EVPLAN Real Time bandwidth on an EVC. A nonrecurring setup charge will apply per ERS EVC. EVCs are purchased on a Month-to-Month basis. A customer may have more than one service class on the EVC, but will only pay one EVC nonrecurring setup charge.

The number of EVCs permitted on each Standard Access Line and/or Premier Access Line are limited as follows:

- 10 Mbps less than or = to 5 EVCs
- 100 Mbps less than or = to 16 EVCs
- 1000 Mbps less than or = to 250 EVCs
- 10 Gbps less than or = 750 EVCs

ADVANCED DATA SERVICES

J. TRANSPARENT LAN SERVICE (TLS) (Continued)

4. APPLICATION OF RATES AND CHARGES (Continued)

(a) The following rate elements are applicable to TLS: (Continued)

(2) Ethernet Virtual Circuit (EVC) - Continued

ERS-Basic, ERS-Priority Data and ERS-Real Time EVC bandwidth is limited to a maximum Mbps per Service Class per EVC, and must comply with each of the following maximum limits:

EVC Service Class	10 Mbps UNI Max/EVC	100 Mbps UNI Max/EVC	1000 Mbps UNI Max/EVC	10 Gbps UNI Max/EVC
ERS-B (or) EVPLAN-B	10 Mbps	100 Mbps	1000 Mbps	1000 Mbps
ERS-PD	10 Mbps	100 Mbps	500 Mbps	500 Mbps
ERS-RT (or) EVPLAN-RT	10 Mbps	100 Mbps	100 Mbps	100 Mbps
	10 Mbps	50 Mbps	50 Mbps	N/A

(3) Interoffice Mileage

The Interoffice Mileage charge is based on the Per Mile charge multiplied by the distance between the customer's serving central office and the nearest TLS equipped central office (a central office equipped with a switch, node, or other Utility equipment capable of delivering service, via a shared fiber path or network infra-structure). This interoffice distance is measured in airline miles, based upon latitude and longitude of each central office. The mileage measurement is calculated as specified by NECA Tariff FCC No. 4. The mileage rate applies on a per mile basis. This charge applies in addition to the applicable rates and charges for all UNI Port with Access Line connections. For standard and premier 'unprotected' UNI Port and Access at the 10Mbps, 100Mbps and 1000Mbps UNI speed, the first twenty Interoffice miles are included in the monthly recurring charge (MRC) of the 'unprotected' UNI Port and Access. Optical protected mileage interoffice transport is available for the 1000M UNI speed. The protected transport option for 10/100Mbps, Protected Non-Diverse and Protected Diverse, UNI speeds includes optical protected interoffice transport when needed.

(4) Domain/LAN Extension Equipment Changes

Customer requests for changes in EMS Domains and replacement of LAN extension equipment will be charged a nonrecurring charge per location per change.

Effective: April 1, 2016

---

ADVANCED DATA SERVICES

J. TRANSPARENT LAN SERVICE (TLS) (Continued)

4. APPLICATION OF RATES AND CHARGES (Continued)

(a) The following rate elements are applicable to TLS: (Continued)

(5) Optional Features

(i) Customer Service Management (CSM)<sup>1</sup>

Customer Service Management (CSM) is an optional feature that provides customers with web-based reports. These reports give customers the ability to extract read-only network traffic information regarding their networks, thereby allowing customers to monitor and manage their network performance. CSM reports are provided per customer Domain/VLAN.

The Utility reserves the right to temporarily interrupt CSM for maintenance, software upgrades, and in emergency situations.

A monthly rate and a nonrecurring charge apply for each CSM arrangement. The customer will be charged on a per Domain/VLAN basis. The nonrecurring charge applies to the initial installation in addition to all other applicable service charges.

(b) Minimum Period

The minimum subscription period for TLS under the Month-to-Month Option is nine months. For example, if the customer discontinues the service in the seventh month, the customer will be billed the full monthly rate for the remaining two months.

(c) Term Commitment Plans

The Standard Access Line, Protected Access Line\*, Premier Access Line and/or EMS Real Time Access Line are offered under a 3 or 5 Year Term Commitment Plan.

(d) Moves and Changes

When the customer requests a move or relocation of the Standard Access Line, Protected Access Line\*, Premier Access Line or EMS Real Time Access Line to a different address and/or different building, the move or relocation will be treated as a termination of the existing service and the establishment of a new service with the application of all installation charges.

When the customer requests an upgrade in service speed, or change in service type, at an existing address, the upgrade in service speed/change in service type will be treated as a termination of the existing service and the establishment of a new service with the application of all charges.

<sup>1</sup> Effective February 7, 2011 CSM is no longer available to new Customers. Moves, additions or changes to subscribers' existing service will not be permitted.

Effective: April 1, 2016

---

ADVANCED DATA SERVICES

J. TRANSPARENT LAN SERVICE (TLS) (Continued)

4. APPLICATION OF RATES AND CHARGES (Continued)

(e) Termination Liability

In the event TLS is terminated by the customer prior to completion of the initial term commitment period, termination liability charges, as set forth in Frontier Product Guide, Section 2.15, will apply, including all termination liability exclusions.

A change in TLS service type will be considered a change to another service for purposes of determining Termination Liability charges.

(f) Service Level Agreements (SLAs)

Service Level Agreements (SLAs) provide TLS customers with Service Response Credits (SRCs) applied to their Frontier bill if the Utility fails to meet certain operational and network thresholds. SLAs are available at no additional charge or fee to the customer.

A customer is eligible for the SLA SRC given the customer adheres to the conditions stated within this section. The SLA specifies performance criteria against which actual performance for TLS will be compared on a monthly basis.

The TLS SLA includes the following measurements:

- Operational SLAs
  - Mean Time to Repair (MTTR)
  - Network Availability
- Network Performance SLAs
  - Ethernet Virtual Circuit (EVC) Class of Service (CoS) Performance
    - Data Delivery Ratio (DDR)
    - Round Trip Delay (RTD)
    - Jitter

The SLA SRC will apply to the following TLS elements:

- UNI Port with Access Line Connection
- Ethernet Virtual Circuit (EVC) Bandwidth, excluding EVPLAN EVCs.

To receive SRCs on eligible rate elements, the customer must have the eligible rate elements listed in the initial subscription based on the established customer of record, or have ordered the eligible rate elements subsequent to the initial subscription. The Utility reserves the right to change, alter or discontinue the optional SRC plan at its discretion.

---

ADVANCED DATA SERVICES

J. TRANSPARENT LAN SERVICE (TLS) (Continued)

4. APPLICATION OF RATES AND CHARGES (Continued)

(f) Service Level Agreements (SLAs) (Continued)

All service performance and provisioning measurements are conducted using the Utility monitoring systems and procedures. The Utility may change these systems and procedures at its sole discretion. In performing measurements of overall Mean Time To Repair (MTTR) and Network Availability, the Utility shall include data measured throughout the territories covered by this Product Guide.

To receive credit, the Utility must receive from the customer a written request for credit within thirty (30) calendar days of the end of the monitoring period that the SRC is referencing. The customer's request for credit must be submitted to the appropriate Utility entity (office or interface) in a manner prescribed by Utility. The request must include a list of all impacted circuit/connection identification numbers and the type of SRC requested for each circuit/connection. The SRC monitoring period is based on a calendar month.

1. Operational Service Level Agreements (SLAs)

(a) Mean Time to Repair (MTTR)

MTTR is the average mean time for the Utility to repair customer reported interruptions for service that is within the Utility's network. A TLS service is interrupted when it becomes unusable to the customer because of a failure of a facility component within the Utility's network that is used to furnish service under this Product Guide.

MTTR Measurement

Under the MTTR SLA, the Utility will measure the average Time to Repair (TTR) for customer-reported interruptions in the services with respect to TLS Access Lines. To be measured under this SLA, the customer must report any interruption to a Utility-designated entity for the opening of a trouble ticket. The TTR is measured from the date and time a trouble ticket is opened by the Utility and the date and time when such ticket is closed by the Utility. In measuring the TTR, any stop clock time or adjusted duration time associated with the trouble shall be subtracted from such measurement.

For purposes of this measurement, stop clock time refers to

- (1) periods when the customer testing is occurring;
- (2) periods when the Utility is awaiting the customer's authorization to commence work on a TLS Access Line;
- (3) periods when the Utility is denied access to the customer's premises or facilities as necessary to diagnose, repair or test;
- (4) periods following a repair of a TLS Access line when the ticket is held open by the customer to ensure the trouble is resolved; and,
- (5) any time period during which any of the listed occurrences existed, as set forth in d. SLA Exclusions following.

---

ADVANCED DATA SERVICES

J. TRANSPARENT LAN SERVICE (TLS) (Continued)

4. APPLICATION OF RATES AND CHARGES (Continued)

(f) Service Level Agreements (SLAs) (Continued)

1. Operational Service Level Agreements (SLAs) (Continued)

(a) Mean Time to Repair (MTTR) (Continued)

MTTR Measurement (Continued)

The SLA shall not apply to cases of trouble where no trouble was found or repeated cases of trouble for the same interruption. The MTTR SLA shall be measured on a calendar month basis and shall be calculated by adding the TTR for all interruptions and dividing that sum by the total number of trouble tickets opened for interruptions for the customer during that month.

MTTR SRCs

If the MTTR is greater than four (4) hours over the calendar month, then 50% of the one month TLS Access Line monthly charge shall be given as a MTTR SRC for those Access Lines which have been out of service for longer than four (4) hours and have been reported by the customer via a trouble ticket to the Utility. The MTTR SRC credit excludes and is not applicable to scheduled maintenance, scheduled downtimes or delays resulting from an event of force majeure.

(b) Network Availability

Network Availability refers to the percentage of time during a calendar month that the TLS is available for use by the customer.

Network Availability Measurement

The Utility threshold for Network Availability is 99.90%. Network Availability is calculated on a per TLS Port Connection basis as follows:

$$\frac{((24 \times \text{Number of Days in Month} \times \text{Number of TLS Port Connections}) - (\text{Number of Hours Out of Service during Month}))}{(24 \times \text{Number of Days in Month} \times \text{Number of TLS Port Connections})}$$

The Utility will not round up the calculation to reach the 99.90% threshold. This SLA is only available for outages reported by the customer via a trouble ticket to the Utility.

Network Availability SRCs

If the overall Network Availability measurement is less than the threshold of 99.90% for a calendar month, the Utility will provide a credit equal to ten percent (10%) of the associated monthly charge for any individual TLS port connection that did not meet such threshold during such calendar month.



---

ADVANCED DATA SERVICES

J. TRANSPARENT LAN SERVICE (TLS) (Continued)

4. APPLICATION OF RATES AND CHARGES (Continued)

(f) Service Level Agreements (SLAs) (Continued)

2. Network Performance SLA

Network Performance SLA applies to all customers subscribing to an EVC Class of Service (CoS) within a local network consisting of the following types:

- Real Time EVC bandwidth CoS, and
- Priority Data EVC bandwidth CoS.
- All other EVCs do not qualify for Network Performance SLA, including EVPLAN EVCs.

The performance SLA is hierarchical in nature and statistically-based. Conformance is determined on a Met or Missed basis, first on a per-hour basis and then on a per-month conformance basis.

**Per-Hour Conformance** - For each hour in the month, a determination is made as to whether the performance objectives are 'Met' for the CoS attributes related to the CoS instance on a given EVC. For a given Hour (e.g., H1), the overall performance objective is 'Met' if the performance objectives for each of the Data Delivery Ratio (DDR), Round Trip Delay (RTD), and Jitter, attributes are 'Met'. If any of the attribute objectives are 'Missed', then the overall performance objective for Hour (H1) is determined to be 'Missed'.

**Per-Month Conformance** - For the month, a determination is made as to the percentage of hours that the overall performance objective is 'Met'. So, for a given Month (e.g., M1), the monthly performance guarantee is 'Met' if the % of hours 'Met' for the month meet or exceed the monthly objective.

EVC Class of Service Network Performance SLA shall be based on the following Ethernet frame traffic criteria:

(a) Data Delivery Ratio (DDR)

DDR is defined as the ratio of service frames successfully received from the network relative to the number of service frames offered to the network. The DDR definition is restricted to service frames that are compliant to the subscribed Committed Information Rate (CIR) profile. Interruptions caused by MTTR activity shall be excluded from the measurement of DDR.

Real Time EVC Bandwidth - Data Delivery Ratio

The Utility threshold for Data Delivery Ratio is 99.5% in a calendar month.

---

ADVANCED DATA SERVICES

J. TRANSPARENT LAN SERVICE (TLS) (Continued)

4. APPLICATION OF RATES AND CHARGES (Continued)

(f) Service Level Agreements (SLAs) (Continued)

2. Network Performance SLA (Continued)

(a) Data Delivery Ratio (DDR) (Continued)

EVC Class of Service Network Performance SLA shall be based on the following Ethernet frame traffic criteria:

Real Time EVC Bandwidth - Data Delivery SRCs

If the overall Data Delivery measurement does not meet the per month conformance, the Utility shall provide an SRC equal to ten percent (10%) of the monthly charge for any individual EVC that did not meet such threshold during such calendar month.

Priority Data EVC Bandwidth - Data Delivery Ratio

The Utility threshold for Data Delivery Ratio is 99% in a calendar month.

Priority Data EVC Bandwidth - Data Delivery SRCs

If the overall Data Delivery measurement does not meet the per month conformance, the Utility shall provide an SRC equal to ten percent (10%) of the monthly charge for any individual EVC that did not meet such threshold during such calendar month.

(b) Round Trip Delay (RTD)

RTD is defined as the time (in milliseconds) it takes for a service frame to be sent from one UNI to another UNI and back again (includes link insertion delays, propagation delays and queuing delays in the network). The RTD calculation includes only the time the packet is in the network, i.e., the processing time spent in devices attached to the UNI are factored out of the definition. The RTD definition is restricted to service frames that are compliant to the subscribed CIR profile.

Real Time EVC Bandwidth - Delay Measurement

The Utility threshold for Delay is 20 milliseconds.

Real Time EVC Bandwidth - Delay SRCs

If the overall delay measurement does not meet the per month conformance, the Utility shall provide an SRC equal to ten percent (10%) of the monthly charge for any individual EVC that did not meet such threshold during such calendar month.

---

ADVANCED DATA SERVICES

J. TRANSPARENT LAN SERVICE (TLS) (Continued)

4. APPLICATION OF RATES AND CHARGES (Continued)

(f) Service Level Agreements (SLAs) (Continued)

2. Network Performance SLA (Continued)

(b) Round Trip Delay (RTD) (Continued)

Priority Data EVC Bandwidth - Delay Measurement

The Utility threshold for Delay is 50 milliseconds.

Priority Data EVC Bandwidth - Delay SRCs

If the overall delay measurement does not meet the per month conformance, the Utility shall provide an SRC equal to ten percent (10%) of the monthly charge for any individual EVC that did not meet such threshold during such calendar month.

(c) Jitter

Jitter is defined as the variance in frame delay (in milliseconds) between two service frames as measured at the ingress and egress UNIs. The jitter definition is restricted to service frames that are compliant to the subscribed CIR profile.

Real Time EVC Bandwidth - Jitter Measurement

The Utility threshold for Delay is 5 milliseconds.

Real Time EVC Bandwidth - Jitter SRC

If the overall jitter measurement does not meet the per month conformance, the Utility shall provide an SRC equal to ten percent (10%) of the monthly charge for any individual EVC that did not meet such threshold during such calendar month.

3. Validation for Operational and Network Performance SLAs

(a) Customer Validation

Operational SLAs:

The customer must submit in writing a list of all rate elements, impacted circuit/connection identification numbers and the type of SRC requested for each circuit/connection. The written request for credit must be submitted to the appropriate Utility entity in the manner prescribed by the Utility.

---

ADVANCED DATA SERVICES

J. TRANSPARENT LAN SERVICE (TLS) (Continued)

4. APPLICATION OF RATES AND CHARGES (Continued)

(f) Service Level Agreements (SLAs) (Continued)

3. Validation for Operational and Network Performance SLAs (Continued)

(a) Customer Validation (Cont'd)

Network Performance SLAs:

The customer must request SRCs for Network Performance SLAs and may submit in support of such request its own measurements made by industry-standard network performance measuring equipment. Such equipment shall be subject to prior approval by the Utility and be capable of the following:

**For the DDR SLA**, the equipment must be capable of determining the number of actual packets sent and successfully received between two (2) customer locations.

**For the RTD SLA**, the equipment must be capable of measuring the transmission of a series of 128-byte time-stamped packets to a measurement system from one customer location to another customer location. The measurement systems must be time-synchronized by using a network based timing source that uses Greenwich Mean Time (GMT).

**For the Jitter SLA**, the equipment must be capable of measuring the transmission of a series of at least fifty (50), 128-byte time stamped packets at a fixed interval between each packet from one customer location to a measurement system at another customer location. The measurement systems must be time-synchronized by using a network based timing source that uses Greenwich Mean Time (GMT).

All equipment must be capable of measuring from edge to edge (Customer Premises Equipment (CPE) to CPE) and to make the measurement every five (5) minutes per hour for four (4) hours total per day, for a total of two-hundred and forty (240) measures per day. In order to be considered, such measurements must include at least seven consecutive days' worth of measurements for four (4) hours per day.

(b) Utility Validation

The Utility will research and validate the customer-submitted SRC in accordance with its own procedures and systems. The Utility may, at its discretion, use either the customer-provided data or its own measurement data (or above mentioned formulas) to evaluate and assess whether SRCs are warranted.

---

ADVANCED DATA SERVICES

J. TRANSPARENT LAN SERVICE (TLS) (Continued)

4. APPLICATION OF RATES AND CHARGES (Continued)

(f) Service Level Agreements (SLAs) (Continued)

4. SLA Exclusions

SLAs do not apply to the extent that any of the following reasons prevented the Utility from meeting such SLAs:

- (a) The acts of the customer or other party authorized by the customer to use the TLS circuit/connection, including but not limited to customer's negligence, customer's refusal to grant the Utility reasonable access to its premises for testing/repair, customer's refusal to release the TLS circuit/connection for testing and/or repair, customer's maintenance activities or its rearrangement of the TLS circuit/connection or where the customer has exceeded the purchased EVC bandwidth;
- (b) Subsequent reports (i.e., additional customer inquiries) while the trouble is pending;
- (c) Service troubles closed due to the customer's action;
- (d) Service troubles repaired by the Utility prior to its receipt of a trouble report;
- (e) Service trouble caused by the customer's CPE or facilities on its side of the demarcation point or any power, equipment, service or systems not provided by the Utility;
- (f) An Interruption related to the provisioning of a new TLS Access Line or Access Lines in service for less than a month;
- (g) Scheduled maintenance and downtimes;
- (h) Unavailability of network monitoring or management equipment or reporting;
- (i) Any other reason outside the control of the Utility.

5. Limitations on SRCs

The combined total of any SRCs applied to the customer's TLS service for a calendar month must meet the following conditions:

- (a) For any calendar year, the total SRCs shall not exceed ten percent (10%) of the total annual revenue of the prior calendar year billed to the customer for qualifying service elements, or \$200,000 per customer, whichever is less. For any calendar year in which the customer had less than twelve (12) full months of revenue for qualifying service elements in the prior calendar year, the SRCs may not exceed \$20,000 per customer for TLS Network.
- (b) To receive an SRC, the customer must request such SRC in writing within thirty (30) calendar days of the end of the monitoring period of the referenced SRC. The request must include a list of all impacted EVC identification numbers and the type of SRC requested for each EVC.

Effective: April 1, 2016

ADVANCED DATA SERVICES

J. TRANSPARENT LAN SERVICE (TLS) (Continued)

5. RATES AND CHARGES

(a) (EMS) - Standard Access Line	Nonrecurring <u>Charge</u> <sup>1</sup>	Monthly <u>Rate</u>
(EMS or ERS) UNI Port with Access		
<u>Month-to-Month Option</u> <sup>2</sup>		
10 Mbps	\$1,300.00	\$1,200.00
100 Mbps	1,300.00	2,400.00
1000 Mbps	1,300.00	4,000.00
10 Gbps	1,300.00	11,000.00
<u>Term Commitment Plans</u>		
3 Year Term		
10 Mbps	--	1,000.00
100 Mbps	--	2,000.00
1000 Mbps	--	3,500.00
10 Gbps	--	9,500.00
5 Year Term		
10 Mbps	--	900.00
100 Mbps	--	1,800.00
1000 Mbps	--	3,200.00
10 Gbps	--	8,500.00
(EMS) UNI Port with Standard Access – Protected Non-Diverse		
<u>Month-to-Month Option</u> <sup>2</sup>		
10 Mbps	1,300.00	1,600.00
100 Mbps	1,300.00	2,600.00
1000 Mbps	1,300.00	9,000.00
<u>Term Commitment Plans</u>		
3 Year Term		
10 Mbps	--	1,400.00
100 Mbps	--	2,400.00
1000 Mbps	--	8,000.00
5 Year Term		
10 Mbps	--	1,300.00
100 Mbps	--	2,100.00
1000 Mbps	--	7,000.00

<sup>1</sup> See Section 3 for applicable nonrecurring charges.

<sup>2</sup> The minimum subscription period for the Month-to-Month Option is nine months.

Effective: April 1, 2016

ADVANCED DATA SERVICES

J. TRANSPARENT LAN SERVICE (TLS) (Continued)

5. RATES AND CHARGES (Continued)

(a) (EMS) - Standard Access Line (Continued)

(EMS) UNI Port with Standard Access – Protected Diverse

	<u>Nonrecurring Charge</u> <sup>1</sup>	<u>Monthly Rate</u>
<u>Month-to-Month Option</u> <sup>2</sup>		
10 Mbps	\$1,300.00	\$1,900.00
100 Mbps	1,300.00	3,000.00
1000 Mbps	1,300.00	9,500.00
<u>Term Commitment Plans</u>		
3 Year Term		
10 Mbps	--	1,800.00
100 Mbps	--	2,800.00
1000 Mbps	--	8,500.00
5 Year Term		
10 Mbps	--	1,700.00
100 Mbps	--	2,500.00
1000 Mbps	--	7,500.00

(EMS) UNI Port with Standard Access – Protected Private

<u>Month-to-Month Option</u> <sup>2</sup>		
10 Mbps	1,300.00	700.00
100 Mbps	1,300.00	900.00
1000 Mbps	1,300.00	2,600.00
<u>Term Commitment Plans</u>		
3 Year Term		
10 Mbps	--	600.00
100 Mbps	--	800.00
1000 Mbps	--	2,400.00
5 Year Term		
10 Mbps	--	500.00
100 Mbps	--	700.00
1000 Mbps	--	2,000.00

<sup>1</sup> See Section 3 for applicable nonrecurring charges.

<sup>2</sup> The minimum subscription period for the Month-to-Month Option is nine months.

Effective: April 1, 2016

ADVANCED DATA SERVICES

J. TRANSPARENT LAN SERVICE (TLS) (Continued)

5. RATES AND CHARGES (Continued)

(b) (EMS) – Protected Access Line, per line <sup>3</sup>

	<u>Nonrecurring Charge</u> <sup>1</sup>	<u>Monthly Rate</u>
<u>Month-to-Month Option</u> <sup>2</sup>		
10 Mbps	N/A	N/A
100 Mbps	N/A	N/A
1000 Mbps	N/A	N/A
<u>Term Commitment Plans</u>		
3 Year Term		
10 Mbps	N/A	N/A
100 Mbps	N/A	3,000.00
1000 Mbps	N/A	5,200.00
5 Year Term		
10 Mbps	N/A	N/A
100 Mbps	N/A	2,700.00
1000 Mbps	N/A	4,800.00

(c) (EMS) Real Time Access Line

(EMS) UNI Port with Real Time Access

<u>Month-to-Month Option</u> <sup>2</sup>		
100 Mbps	1,300.00	2,500.00
1000 Mbps	1,300.00	4,500.00
10 Gbps	1,300.00	12,500.00
<u>Term Commitment Plans</u>		
3 Year Term		
100 Mbps	--	2,100.00
1000 Mbps	--	4,000.00
10 Gbps	--	11,000.00
5 Year Term		
100 Mbps	--	1,900.00
1000 Mbps	--	3,700.00
10 Gbps	--	10,000.00

<sup>1</sup> See Frontier California Inc. Product Guide, Section 3 for applicable nonrecurring charges.

<sup>2</sup> The minimum subscription period for the Month-to-Month Option is nine months.

<sup>3</sup> Effective November 19, 2010, this service will no longer be available to new customers.



Effective: April 1, 2016

ADVANCED DATA SERVICES

J. TRANSPARENT LAN SERVICE (TLS) (Continued)

5. RATES AND CHARGES (Continued)

(c) (EMS) Real Time Access Line (Continued)

(EMS) UNI Port with Real Time Access – Protected Non – Diverse

	<u>Nonrecurring Charge</u> <sup>1</sup>	<u>Monthly Rate</u>
<u>Month-to-Month Option</u> <sup>2</sup>		
10 Mbps	N/A	N/A
100 Mbps	\$1,300.00	\$2,700.00
1000 Mbps	1,300.00	10,000.00
<u>Term Commitment Plans</u>		
3 Year Term		
10 Mbps	--	N/A
100 Mbps	--	2,500.00
1000 Mbps	--	9,000.00
5 Year Term		
10 Mbps	--	N/A
100 Mbps	--	2,300.00
1000 Mbps	--	8,500.00

(EMS) UNI Port with Real Time Access – Protected Diverse

<u>Month-to-Month Option</u> <sup>2</sup>		
10 Mbps	N/A	N/A
100 Mbps	1,300.00	3,250.00
1000 Mbps	1,300.00	11,000.00
<u>Term Commitment Plans</u>		
3 Year Term		
10 Mbps	--	N/A
100 Mbps	--	3,000.00
1000 Mbps	--	10,000.00
5 Year Term		
10 Mbps	--	N/A
100 Mbps	--	2,750.00
1000 Mbps	--	9,000.00

<sup>1</sup> See Section 3 for applicable nonrecurring charges.

<sup>2</sup> The minimum subscription period for the Month-to-Month Option is nine months.

Effective: April 1, 2016

ADVANCED DATA SERVICES

J. TRANSPARENT LAN SERVICE (TLS) (Continued)

5. RATES AND CHARGES (Continued)

(c) (EMS) Real Time Access Line (Continued)

(EMS) UNI Port with Real Time Access - Protected Private

	<u>Nonrecurring Charge</u> <sup>1</sup>	<u>Monthly Rate</u>
<u>Month-to-Month Option</u> <sup>2</sup>		
10 Mbps	N/A	N/A
100 Mbps	\$1,300.00	\$950.00
1000 Mbps	1,300.00	2,700.00
<u>Term Commitment Plans</u>		
3 Year Term		
10 Mbps	--	N/A
100 Mbps	--	850.00
1000 Mbps	1,300.00	2,500.00
5 Year Term		
10 Mbps	N/A	N/A
100 Mbps	N/A	750.00
1000 Mbps	N/A	2,100.00

(d) ERS – Premier Access Line

<u>Month-to-Month Option</u> <sup>2</sup>		
10 Mbps	1,300.00	1,075.00
100 Mbps	1,300.00	1,200.00
1000 Mbps	1,300.00	2,400.00
10000 Mbps	1,300.00	10,000.00
<u>Term Commitment Plans</u>		
3 Year Term		
10 Mbps	--	875.00
100 Mbps	--	1,000.00
1000 Mbps	--	2,000.00
10000 Mbps	--	9,000.00
5 Year Term		
10 Mbps	--	775.00
100 Mbps	--	900.00
1000 Mbps	--	1,800.00
10000 Mbps	--	8,000.00

<sup>1</sup> See Section 3 for applicable nonrecurring charges.

<sup>2</sup> The minimum subscription period for the Month-to-Month Option is nine months.

Effective: April 1, 2016

ADVANCED DATA SERVICES

J. TRANSPARENT LAN SERVICE (TLS) (Continued)

5. RATES AND CHARGES (Continued)

(d) ERS – Premier Access Line (Continued)

(ERS) UNI Port with Premier Access – Protected Non - Diverse

	<u>Nonrecurring Charge</u> <sup>1</sup>	<u>Monthly Rate</u>
<u>Month-to-Month Option</u> <sup>2</sup>		
10 Mbps	\$1,300.00	\$1,050.00
100 Mbps	1,300.00	1,900.00
1000 Mbps	1,300.00	7,500.00
<u>Term Commitment Plans</u>		
3 Year Term		
10 Mbps	--	900.00
100 Mbps	--	1,600.00
1000 Mbps	--	7,500.00
5 Year Term		
10 Mbps	--	750.00
100 Mbps	--	1,450.00
1000 Mbps	--	6,500.00

(ERS) UNI Port with Premier Access – Protected Diverse

<u>Month-to-Month Option</u> <sup>2</sup>		
10 Mbps	1,300.00	1,200.00
100 Mbps	1,300.00	2,150.00
1000 Mbps	1,300.00	9,000.00
<u>Term Commitment Plans</u>		
3 Year Term		
10 Mbps	--	1,000.00
100 Mbps	--	1,800.00
1000 Mbps	--	8,500.00
5 Year Term		
10 Mbps	--	850.00
100 Mbps	--	1,600.00
1000 Mbps	--	8,000.00

<sup>1</sup> See Section 3 for applicable nonrecurring charges.

<sup>2</sup> The minimum subscription period for the Month-to-Month Option is nine months.

Effective: April 1, 2016

ADVANCED DATA SERVICES

J. TRANSPARENT LAN SERVICE (TLS) (Continued)

5. RATES AND CHARGES (Continued)

(d) ERS – Premier Access Line (Continued)

(ERS) UNI Port with Premier Access – Protected Private

	<u>Nonrecurring Charge</u> <sup>1</sup>	<u>Monthly Rate</u>
<u>Month to Month Plan</u>		
10 Mbps.	\$1,300.00	\$600.00
100 Mbps.	1,300.00	700.00
1000 Mbps.	1,300.00	1,700.00
<u>Term Commitment Plans</u>		
3 Year Plan		
10 Mbps.	N/A	500.00
100 Mbps.	N/A	600.00
1000 Mbps.	N/A	1,550.00
5 Year Plan		
10 Mbps.	N/A	400.00
100 Mbps.	N/A	500.00
1000 Mbps.	N/A	1,400.00
(e) ERS – Ethernet Virtual Circuit ERS Standard, Premier and EVP-LAN EVC Setup, per EVC	200.00	--

<sup>1</sup> See Section 3 for applicable nonrecurring charges.

<sup>2</sup> The minimum subscription period for the Month-to-Month Option is nine months.

Effective: April 1, 2016

ADVANCED DATA SERVICES

J. TRANSPARENT LAN SERVICE (TLS) (Continued)

5. RATES AND CHARGES (Continued)

(e) ERS – Ethernet Virtual Circuit (Continued)

(ERS) EVC Standard (ERS-Std), per EVC

	Nonrecurring Charge <sup>1</sup>	Monthly Rate
10 Mbps	--	\$50.00
100 Mbps	--	100.00
1000 Mbps	--	200.00

(ERS) Premier Basic (ERS-B) Bandwidth, per Class

1 Mbps	N/A	15.00
2 Mbps	N/A	30.00
3 Mbps	N/A	45.00
4 Mbps	N/A	60.00
5 Mbps	N/A	75.00
6 Mbps	N/A	90.00
7 Mbps	N/A	105.00
8 Mbps	N/A	120.00
9 Mbps	N/A	135.00
10 Mbps	N/A	150.00
20 Mbps	N/A	300.00
30 Mbps	N/A	450.00
40 Mbps	N/A	600.00
50 Mbps	N/A	750.00
60 Mbps	N/A	850.00
70 Mbps	N/A	950.00
80 Mbps	N/A	1,050.00
90 Mbps	N/A	1,150.00
100 Mbps	N/A	1,250.00
200 Mbps	N/A	1,350.00
300 Mbps	N/A	1,450.00
400 Mbps	N/A	1,550.00
500 Mbps	N/A	1,650.00
600 Mbps	N/A	1,740.00
700 Mbps	N/A	1,830.00
800 Mbps	N/A	1,920.00
900 Mbps	N/A	2,010.00
1000 Mbps	N/A	2,100.00

<sup>1</sup> See Section 3 for applicable nonrecurring charges.

Effective: April 1, 2016

---

ADVANCED DATA SERVICES

J. TRANSPARENT LAN SERVICE (TLS) (Continued)

5. RATES AND CHARGES (Continued)

(e) ERS – Ethernet Virtual Circuit (Continued)

(ERS) EVC Premier Priority Data (ERS-PD) Bandwidth, per Class

	<u>Nonrecurring Charge</u> <sup>1</sup>	<u>Monthly Rate</u>
1 Mbps	N/A	\$40.00
2 Mbps	N/A	80.00
3 Mbps	N/A	120.00
4 Mbps	N/A	160.00
5 Mbps	N/A	200.00
6 Mbps	N/A	220.00
7 Mbps	N/A	240.00
8 Mbps	N/A	260.00
9 Mbps	N/A	280.00
10 Mbps	N/A	300.00
20 Mbps	N/A	600.00
30 Mbps	N/A	900.00
40 Mbps	N/A	1,200.00
50 Mbps	N/A	1,500.00
60 Mbps	N/A	1,720.00
70 Mbps	N/A	1,940.00
80 Mbps	N/A	2,100.00
90 Mbps	N/A	2,300.00
100 Mbps	N/A	2,500.00
200 Mbps	N/A	2,700.00
300 Mbps	N/A	2,900.00
400 Mbps	N/A	3,100.00
500 Mbps	N/A	3,300.00

<sup>1</sup> See Section 3 for applicable nonrecurring charges.

Effective: April 1, 2016

---

ADVANCED DATA SERVICES

J. TRANSPARENT LAN SERVICE (TLS) (Continued)

5. RATES AND CHARGES (Continued)

(e) ERS – Ethernet Virtual Circuit (Continued)

(ERS) EVC Premier Real Time (ERS-RT) Bandwidth, per Class

	<u>Nonrecurring Charge</u> <sup>1</sup>	<u>Monthly Rate</u>
1 Mbps	N/A	\$120.00
2 Mbps	N/A	240.00
3 Mbps	N/A	360.00
4 Mbps	N/A	480.00
5 Mbps	N/A	600.00
6 Mbps	N/A	660.00
7 Mbps	N/A	720.00
8 Mbps	N/A	780.00
9 Mbps	N/A	840.00
10 Mbps	N/A	900.00
20 Mbps	N/A	1,175.00
30 Mbps	N/A	1,450.00
40 Mbps	N/A	1,725.00
50 Mbps	N/A	2,000.00
60 Mbps	N/A	2,200.00
70 Mbps	N/A	2,400.00
80 Mbps	N/A	2,600.00
90 Mbps	N/A	2,800.00
100 Mbps	N/A	3,000.00

<sup>1</sup> See Section 3 for applicable nonrecurring charges

Effective: April 1, 2016

---

ADVANCED DATA SERVICES

J. TRANSPARENT LAN SERVICE (TLS) (Continued)

5. RATES AND CHARGES (Continued)

(e) ERS – Ethernet Virtual Circuit (Continued)

(ERS) EVP-LAN Basic (EVPLAN-B) Bandwidth, per Class

	<u>Nonrecurring Charge</u> <sup>1</sup>	<u>Monthly Rate</u>
1 Mbps	N/A	\$16.00
2 Mbps	N/A	32.00
3 Mbps	N/A	48.00
4 Mbps	N/A	64.00
5 Mbps	N/A	80.00
6 Mbps	N/A	96.00
7 Mbps	N/A	112.00
8 Mbps	N/A	128.00
9 Mbps	N/A	144.00
10 Mbps	N/A	160.00
20 Mbps	N/A	315.00
30 Mbps	N/A	470.00
40 Mbps	N/A	625.00
50 Mbps	N/A	780.00
60 Mbps	N/A	885.00
70 Mbps	N/A	990.00
80 Mbps	N/A	1,200.00
90 Mbps	N/A	1,305.00
100 Mbps	N/A	1,410.00
200 Mbps	N/A	1,515.00
300 Mbps	N/A	1,602.00
400 Mbps	N/A	1,715.00
500 Mbps	N/A	1,810.00
600 Mbps	N/A	1,905.00
700 Mbps	N/A	1,830.00
800 Mbps	N/A	2,000.00
900 Mbps	N/A	2,095.00
1000 Mbps	N/A	2,190.00

<sup>1</sup> See Section 3 for applicable nonrecurring charges.



Effective: April 1, 2016

ADVANCED DATA SERVICES

J. TRANSPARENT LAN SERVICE (TLS) (Continued)

5. RATES AND CHARGES (Continued)

(e) ERS – Ethernet Virtual Circuit (Continued)

(ERS) EVP-LAN Real Time (EVPLAN-RT) Bandwidth, per Class

	<u>Nonrecurring Charge</u> <sup>1</sup>	<u>Monthly Rate</u>
1 Mbps	N/A	\$125.00
2 Mbps	N/A	250.00
3 Mbps	N/A	375.00
4 Mbps	N/A	500.00
5 Mbps	N/A	625.00
6 Mbps	N/A	690.00
7 Mbps	N/A	755.00
8 Mbps	N/A	820.00
9 Mbps	N/A	885.00
10 Mbps	N/A	950.00
20 Mbps	N/A	1,235.00
30 Mbps	N/A	1,520.00
40 Mbps	N/A	1,805.00
50 Mbps	N/A	2,090.00
(f) Interoffice Mileage, per line <sup>2</sup>		
Per Mile	--	100.00
Per Optical Protected Mile	--	750.00
Protected Non-Diverse and Protected Diverse Only		
(g) TLS Domain/LAN Extension Equipment Changes		
Per location, per change	\$400.00	--
(h) Optional Features <sup>3</sup>		
Customer Service Management (CSM), Per Domain	350.00	150.00

<sup>1</sup> See Section 3 for applicable nonrecurring charges

<sup>2</sup> Applies in addition to applicable rates and charges for all UNE Port with Access Line connections.

<sup>3</sup> Effective February 7, 2011, this service will no longer be available to new customers.

Effective: April 1, 2016

---

ADVANCED DATA SERVICES

K. CUSTOM CONNECT SERVICE

1. DESCRIPTION

The Custom Connect Service provides a connection to the Company's Optical network and Customer's designated location (CDL). The Custom Connect is comprised of Central Office (CO) Nodes, CDL Links or SONET Premises Nodes, Transport and Riders. Each Custom Connect must consist of a minimum of two Customer designated locations, one of which must be a CDL Link. The Service is provided where technically and operationally feasible. If adequate facilities do not exist, special construction and other additional charges will apply.

The CDL Link may be Concatenated or Non-concatenated. The Concatenated/Non-concatenated CDL Link may be optionally configured with a four fiber, 1+1 protected network interface, as Single or Diverse Route.

Custom Connect may connect to Intelli Light Optical Transport Service (IOTS) optical transport channels or may be provided over an IOTS backbone network.

Custom Connect may also be connected to the following Company services, provided that such connections are technically and operationally feasible, as determined by the Company:

- dedicated SONET ring service
- point-to-point SONET service
- DWDM ring service
- SONET entrance facility service
- ethernet private line service

Custom Connect may also be provided over a Company provided DWDM ring backbone network provided that such configurations are technically and operationally feasible, as determined by the Telephone Company.

Custom Connect Single Route and Diverse Route at OC12c and OC48c may also connect to an advanced data service at designated Company wire centers.

Effective: April 1, 2016

---

ADVANCED DATA SERVICES

K. CUSTOM CONNECT SERVICE (Continued)

2. RATE ELEMENTS

Central Office (CO) Node

The CO Node is applicable for each central office that is equipped with a fiber optic terminal in which the Customer requests the ability to add/drop traffic to a CDL. Traffic is dropped from the CO Node via ports (lower speed drops). The CO Node may be ordered when a Customer requires OC level multiplexing on the Custom Connect. If the Customer wants to drop traffic below a DS3 at the CO Node, the Customer must request a minimum DS1 interface and appropriate special access lines pursuant to Company's Facilities for Intrastate Access Tariff C-1. The CO Node may also be used when the Customer wants to add/drop DS1 or DS3 traffic to a CDL located between service areas. The OC192 CO Node's ability to drop traffic below an OCn level is limited to new and in-service terminals technically capable of providing such directly from the Add Drop Multiplexer (ADM). See Rider section, herein, for further details. Multiplexing, access line and transport, including applicable rates and charges, from the Facilities for Intrastate Access Tariff C-1 or as set out in the Custom Connect individual case basis contract will apply in addition to the CO Node and appropriate rider charges. However, multiplexing rates will not apply when all of the following conditions are met:

- (1) The Customer requests to drop a DS3 from a CO Node for the purpose of establishing a DS3 multiplexed facility in its serving wire center; and
- (2) the Customer subscribes to and is billed for the CO Node rate element; and
- (3) the Customer CO Node is located in the same central office building where the DS3 multiplexed facility is to be located.

When the CO Node is not located within the wire center serving the CDL, additional charges apply, including but not limited to rates associated with transport of the DS3 facility to the wire center where the CO Node is located and rider charges.

The CO Node, or in the alternative a CDL Link and multiplexer, is also required when Custom Connect provides the optical transmission facilities that connect an advanced data service to a CDL in a different wire center.

The CO Node may be ordered at an OC3, OC12, OC48 or OC192 bandwidth capacity.

Effective: April 1, 2016

---

ADVANCED DATA SERVICES

K. CUSTOM CONNECT SERVICE (Continued)

2. RATE ELEMENTS (Continued)

CDL Link

The CDL Link is applicable for each Customer designated location in which the Customer requests the ability to add/drop traffic. The CDL Link is offered as Single Route Diverse Route, or Ring Route and may be ordered with premise multiplexer provided or with premise fiber meet provided as OC3, OC12, OC48 or OC192 bandwidth capacity. Only one CDL Link per connect may be ordered with premise fiber meet provided. The premise fiber meet will terminate on a fiber cross connect panel at the demarcation point. CDL Link with premise fiber meet is not available for jointly provided meet-point arrangements except where Company provides a node within its network to the Customer.

If more than two Links or Nodes are ordered on the same order, the CDL Link must be ordered as a Ring Route CDL Link. A Ring Route CDL Link has a minimum of three nodes, one of which must be located in a Telephone Company wire center.

Custom Connect Ring Route is available to existing customers only.

The CDL Link may be ordered as Single Route or Diverse Route with concatenated or non-concatenated optical interface for OC3/OC3c, OC12/OC12c, OC48/OC48c, and OC192/OC192c. These CDL Links will terminate on a fiber cross connect panel at the demarcation point. The rider charges are included in the monthly rate for these CDL Links.

The CDL Link may also be ordered as 1.25Gbps and 2.5Gbps Single Route or Diverse Route. This CDL Link cannot ride a higher level facility and can only be ordered CDL to CDL.

When Custom Connect is provided over an Intellilight® Optical Transport Service (IOTS) backbone or Company provided DWDM backbone, and the transport between the nodes is provided using IOTS optical transport channels or DWDM optical transport channels respectively, a SONET Premises Node applies in lieu of the CDL Link to each customer designated location of the Custom Connect ring where SONET multiplexing is required.

CDL Link with Optical Cross Connect

The CDL Link with Optical Cross Connect provides the communications path between the Company's serving wire center end of a CDL Link and an IXC's or ISP's transmission equipment and facilities collocated in the Company's serving wire center. This service element includes the CDL Link from the fiber optic terminal and the optical jumpers that facilitate the cross connect to the IXC's or ISP's transmission equipment and facilities, located within the Company wire center.

The CDL Link with Optical Cross Connect will be provided as a single route without Company provided electronics as OC3, OC3c, OC12 or OC12c as ordered by the customer.

In addition to the rate for the CDL Link with Optical Cross Connect, the appropriate CDL Link rate is applicable from the CDL to the serving wire center, and the appropriate Dedicated Transport rate is applicable between serving wire centers.

---

ADVANCED DATA SERVICES

K. CUSTOM CONNECT SERVICE (Continued)

2. RATE ELEMENTS (Continued)

Transport

Transport may be provisioned as shared or dedicated. Shared Transport is applicable when the transport between Node and/or Links is ordered at different bandwidth levels. The Dedicated Transport is applicable when transport between the Nodes and/or Links is of the same bandwidth level.

Shared Transport may be ordered in bandwidths of DS1, DS3/STS1, OC3, OC3c, OC12, OC12c, OC48 or OC48c. Dedicated Transport may be in bandwidths of OC3, OC3c, OC12, OC12c, OC48, OC48c or OC192, 1.25 Gbps or 2.5 Gbps.

Transport (Shared and Dedicated) is mileage sensitive and will be calculated using airline mileage between serving wire centers based on the V&H coordinates of the wire centers comprising each segment of the connect. Mileage is rounded up to the next whole mile.

When point-to-point Custom Connect is provided over an Intellilight® Optical Transport Service (IOTS) backbone network, connection between the Custom Connect nodes is provided using an IOTS optical transport channel in lieu of Custom Connect transport. When Custom Connect configured in a ring topology is provided over an IOTS backbone network, connection between the SONET nodes (Custom Connect CO Nodes and/or SONET Premises Nodes) is provided using unprotected IOTS optical transport channels in lieu of Custom Connect transport. Since protection is inherent in the Custom Connect service, protection is not required on the IOTS optical transport channels.

Connection of Custom Connect configured in a ring topology to an IOTS ring is provided over an equal speed, unprotected optical transport channel (e.g., an OC3 Custom Connect node would connect to a 155.52 Mbps unprotected IOTS channel). Each node of a Custom Connect ring must be located at the same customer designated location or central office as its corresponding IOTS node.

When point-to-point Custom Connect is provided over a Company provided DWDM backbone network, connection between the Custom Connect nodes is provided using a DWDM optical transport channel in lieu of Custom Connect transport. When Custom Connect configured in a ring topology is provided over a Telephone Company provided DWDM backbone network, connection between the SONET nodes (Custom Connect CO Nodes and/or SONET Premises Nodes) is provided using unprotected DWDM optical transport channels in lieu of Custom Connect transport. Since protection is inherent in the Custom Connect service, protection is not required on the DWDM optical transport channels.

Connection of Custom Connect configured in a ring topology to a Telephone Company provided DWDM ring is provided over an equal speed, unprotected optical transport channel (e.g., an OC3 Custom Connect node would connect to a 155.52 Mbps unprotected DWDM channel). Each node of a Custom Connect ring must be located at the same customer designated location or central office as its corresponding DWDM node.

The Shared Transport rate for Custom Connect Transport DS1 and DS3 bandwidth services apply to the transport facilities connected to Optical Custom Connect services.

Effective: April 1, 2016

---

ADVANCED DATA SERVICES

K. CUSTOM CONNECT SERVICE (Continued)

2. RATE ELEMENTS (Continued)

Rider

The Rider addresses Customer's service(s) traversing a higher bandwidth level. Riders may be at DS1, DS3, OC3, OC3c, OC12, OC12c, OC48, OC48c or STS1 bandwidth levels as required by the Customer.

The Rider is provided at a flat-rated monthly recurring charge, and the Rider charge is applicable per rider circuit order. A Rider is not charged with a CDL Link – Single or Diverse Route – Concatenated/Non-concatenated optical interface.

Four fiber 1+1 protection, consisting of two cards in the add/drop multiplexer, one working card and a second, standby card to provide automatic protection from a fault in the working card, is available with Company provided add/drop multiplexers and with compatible CPE, and applies per CDL. Additional charges apply for this optional protection feature. When a Rider is ordered with four fiber 1+1 protection, the protection charge applies in addition to the charge for the Rider.

In jointly provided meet-point arrangements, rider charges apply in addition to other applicable charges when Company provides any Ocn mux node, whether provided at the Customer premise or in the central office.

Acceptable rider speeds allowed by node type are as follows:

<u>NODES</u>	<u>OC3</u>	<u>OC12</u>	<u>OC48</u>	<u>OC192</u>
DS1 Rider	X	X*	X*	X*
DS3 Rider	X	X	X	X*
STS1 Rider	X	X	X	X
OC3/OC3c Rider		X	X	X
OC12/OC12c Rider			X	X
OC48/OC48c Rider				X

Available only from nodes that are technically capable of providing DS1 and DS3 drops directly from the OCn node terminal. The maximum capacity utilization that can be delivered by a OCn node selected by Customer may be limited by the number and type of riders that are provisioned on the OCn node and are limited by the maximum number of interfaces available to the OCn backplane. Where the OCn terminal is technically capable of supporting lower bandwidth OCn nodes as a sub-multiplexer, Company may provide such at the Customer premise and Central Office Node locations and additional charges will apply.

Effective: April 1, 2016

---

ADVANCED DATA SERVICES

K. CUSTOM CONNECT SERVICE (Continued)

2. RATE ELEMENTS (Continued)

SONET Premises Node – IOTS

The SONET Premises Node rate element applies at each CDL at which a SONET node is needed to complete a Custom Connect ring over an IOTS backbone network. The functionality and capabilities of the SONET Premises Node are the same as those specified for the CO Node preceding. The SONET Premises Node will only be provided when Custom Connect is configured in a ring or point to point topology in which the transport between the nodes (CO Node and/or SONET Premises Nodes) is provided using IOTS optical transport channels. The SONET Premises Node applies in lieu of the Custom Connect CDL Link.

The SONET Premises Node rate element also applies at each CDL at which a SONET node is needed to complete a Custom Connect ring over a Company provided DWDM backbone network. The SONET Premises Node will only be provided when Custom Connect is configured in a ring or point to point topology in which the transport between the nodes (CO Node and/or SONET Premises Nodes) is provided using DWDM optical transport channels. The SONET Premises Node applies in lieu of the Custom Connect CDL Link.

Rate Regulations

The rates and charges will be determined on an Individual Case Basis (ICB). For customers with existing services under ICB contract arrangements, the rates, terms and conditions of such contract arrangements will continue, on a month to month basis, for no more than 180 days upon the expiration of that current contract term, in order for the parties to complete a new contract or transition service to another service.

Moves and Changes

A move involves a change in the physical end points of the Custom Connect Service. Two types of moves are set forth below:

Moves Within the Same CDL - When the move is to a new location within the same CDL (Inside Move), a nonrecurring charge for the Inside Move will be the installation charge for the portion of the Service being re-terminated. No termination liability will apply.

Moves To A Different CDL or Frontier Central Office - Moves to a different CDL or Frontier Central Office (Outside Move) will be treated as a discontinuance and start of a new Service and all associated nonrecurring charges will apply.

Termination Liability

See Section 2 of the Company's ILEC Product Guide for Termination Liability language.

Effective: April 1, 2016

---

ADVANCED INTELLIGENT NETWORK (AIN) SERVICES

TABLE OF CONTENTS

SHEET NO.

A. CUSTOM REDIRECT SERVICE

1. General	1
2. Feature Definitions	1
3. Special Conditions	5
4. Application Of Rates And Charges	7
5. Rates and Charges	10



---

ADVANCED INTELLIGENT NETWORK (AIN) SERVICES

A. CUSTOM REDIRECT SERVICE

1. GENERAL

Custom Redirect Service enables customers to redirect all or a part of their incoming switched voice and data calls to other telephone numbers. The redirection may be on a permanent basis, automatically according to predetermined parameters, and/or upon command by the customer. This service may be used in the event of a communications failure, cable cut, fire, flood, or any other event requiring calls to be handled from alternate telephone numbers or an alternate location.

Basic Custom Redirect Service offers three options to redirect calls. The first option is usually a basic redirect to the dialed number. Options 2 and 3 would be the telephone number(s) the customer wants incoming calls redirected to when Option 1 is not the desired choice. The customer may designate that the basic redirection feature be used in each of the options or, the customer may select a Custom Redirect Optional Feature as described herein.

2. FEATURE DEFINITIONS

a. Standard Features

(1) Equipped Number

Equipped number is the customer's called telephone number that has Custom Redirect Service.

(2) Group

A group is the collection of equipped telephone numbers that will be redirected in the same way, at the same time. For example, if redirection is requested, all telephone numbers within that group will be redirected. If the customer chooses to have option three "active" in a particular group, then all equipped telephone numbers in the group will be redirected according to the direction in option three.

Every group must have the same optional features in each of the options. For example, if the option column has Time-of-Day redirection, then the times that the numbers are redirected are the same for all the numbers in that group. The actual telephone numbers that the calls are redirected to do not have to be the same. For all optional features, the telephone number that the calls are redirected to may be different.

(3) Option Column

An option column is a table of telephone numbers that are treated the same. Custom Redirect has three option columns per group with the basic service. Up to six additional options may be provisioned as an enhancement. If more than three options are chosen the Additional Option charge applies per additional option chosen. Only one option is active for a group at any given time. For example, in a particular group the first option may be the original dialed number, the second option may be the home telephone number, and the third might be a telephone number in an affiliate office in another city. If option two were selected (i.e., "active"), all telephone numbers in this group would be redirected to the respective telephone number in option column two. Similarly, if the customer selected option column three to be in effect and option three was provisioned with a Custom Redirect Service optional feature, then all telephone numbers in this option column would have the optional feature.

Effective: April 1, 2016

---

ADVANCED INTELLIGENT NETWORK (AIN) SERVICES

A. CUSTOM REDIRECT SERVICE (Continued)

2. FEATURE DEFINITIONS (Continued)

a. Standard Features (Continued)

(4) Redirecting Telephone Number

A redirecting telephone number will have no office equipment associated with it and will be used solely for the purposes of redirecting call traffic from the telephone number dialed to the Custom Redirect Service customer's intended destination.

(5) Modification of Active Option

When the customer elects to redirect calls, the customer calls into the Company platform using a Touch-Tone telephone. Upon reaching the platform, the customer must pass through a series of security blocks to get into the system. Calls may also be redirected by calling a live attendant, who, after verifying security information, will establish the redirection of the calls.

After authorization is confirmed, the customer specifies which group and which option the customer wishes to activate. A group may be a floor, department, building, or some other customer-defined list of numbers. These groups are pre-assigned upon the establishment of the service.

The customer may call in to have the active option modified as frequently as desired. When calls are terminated to any number other than the originally-dialed number, redirection charges will apply as they would in Call Forwarding.

b. Optional Features

(1) Alternate Central Office Triggers

The ability to place triggers in central office switches, other than the original terminating central office, allows customers to redirect from the central office in which the call originates without requiring the call to complete to the serving central office. In the event that the serving central office is out of service, the customer's Custom Redirect Service may be activated, and all calls processing in a central office with an alternate central office trigger will be redirected per the current active option at that time. Triggers are associated with one customer NPA-NNX.

Allowing triggers to be placed in more than the terminating central office may increase the call volume queries processed because a portion of the calls may actually be processed by more than one central office. The customer's monthly Group Volume charges would be reflective of this increased call volume.

Effective: April 1, 2016

---

ADVANCED INTELLIGENT NETWORK (AIN) SERVICES

A. CUSTOM REDIRECT SERVICE (Continued)

2. FEATURE DEFINITIONS (Continued)

b. Optional Features (Continued)

(2) Custom Applications

Although most customer applications are provided using the optional features listed herein, custom applications may also be provisioned. Custom applications will include the inclusion in the call processing record a single table or single field manipulation to meet a specific customer's need.

Dialed Number Recovery (DNR) is an example of a Custom Application. DNR presents the original dialed number to a new customer location.

It is not the intent to provide all AIN (Advanced Intelligent Network) custom applications through this guide item. Very complex applications, and applications for purposes other than the directing of incoming calls will not be considered part of this feature and will require special assemblies. Custom applications will be provided on an Individual Case Basis (ICB).

(3) Number Identification Redirection

This feature allows the customer to redirect calls based upon the originating telephone number, NXX, LATA (Local Access and Transport Area), or NPA (Numbering Plan Area) of the incoming caller. With this feature, the customer utilizes a list to assign specific incoming telephone numbers to a number they are to be redirected to. If an incoming caller's number is on the list, the call will be redirected to the number specified on the list. If the incoming caller's telephone number is not on the list, the call will be completed as dialed.

The customer may have as many numbers as desired on the list. The customer will be billed for each 100 numbers or any fraction thereof. Number Identification Redirection may be used with any of the option columns. If this feature is used in more than one option, the optional feature charge applies to each option utilizing the feature.

Number Identification Redirection may not be used to pass the identity of the calling party's number to the customer. This feature in no way replaces, enhances nor interferes with Caller ID as found in Section 6, Custom Calling Services.

(4) Percentage Redirection

Redirection may be done by percentages. For example, when Percentage Redirection is activated, the customer may direct 20% of the incoming calls to location A, 30% to location B, and 50% to location C. The customer may choose up to ten percentages, but the total must always equal 100%. The Percentage Redirection feature may be used with any of the option columns. If this feature is used in more than one option, the optional feature charge applies to each option utilizing the feature.

---

ADVANCED INTELLIGENT NETWORK (AIN) SERVICES

A. CUSTOM REDIRECT SERVICE (Continued)

2. FEATURE DEFINITIONS (Continued)

b. Optional Features (Continued)

(5) Single Number Destination Service

This feature will allow customers to redirect an entire group to a single number provided at the time of activation. At the time of provisioning, customers must designate an interexchange carrier of their choice to carry the redirected traffic. The billing for calls redirected using this feature will be by the carrier specified by the customer.

(6) Special Custom Redirect Service Transaction

Occasionally customers will require a one-time effort related to their Custom Redirect Service. This may include the generation of a special report, out-of-hours programming support for testing, or other special handling of the service that was not included in the rate development for the service. This rate element will allow customers to request such services and the Company to recover the costs associated with these special requests. Should the customer elect to go forward with the transaction developed, charges will be applied on an Individual Case Basis (ICB).

(7) SuperGroups

The customer may choose to group their groups into SuperGroups. A SuperGroup is similar to a distribution list of groups and will allow the customer to modify the active option of multiple groups at the same time. For example if groups 101, 102, and 105 belong to SuperGroup 001, setting SuperGroup 001 to option 3 would set 101, 102 and 105 to option 3.

If the same group is assigned to multiple SuperGroups, the active option would be the last option set. For example, based on the definition of SuperGroup 001 above and an additional SuperGroup 002, which includes groups 103, 104 and 105: If after SuperGroup 001 is set to option 3, SuperGroup 002 is set to option 2, Group 105 would be set to option 2.

(8) Time-of-Day/Day-of-Week Redirection

This optional feature allows customers to redirect the customer's calls to another location at pre-designated times. For example, particular numbers can be redirected to another location after 5 PM, or, just on Saturdays. The system will automatically route these calls until the customer changes the specifications. This will allow the customer to use a single office to perform the work of many locations during the off-peak hours. Time-of-Day/Day-of-Week Redirection may be used with any of the option columns. If this feature is used in more than one option, the optional feature charge applies to each option utilizing the feature.

Effective: April 1, 2016

---

ADVANCED INTELLIGENT NETWORK (AIN) SERVICES

A. CUSTOM REDIRECT SERVICE (Continued)

3. SPECIAL CONDITIONS

- a. Custom Redirect Service is available where Company facilities permit.
- b. Custom Redirect Service may be provisioned with group sizes as small as one.
- c. The rates specified in 5.RATES do not apply to telephone numbers which require excessive translations work. For example, Custom Redirect Service provisioned out of 5ESS<sup>® 1</sup> switches for customers subscribing to Direct Inward Dialing (DID) service would require excessive translations work. Charges for this work will be applied on an Individual Case Basis (ICB).
- d. Each group may have up to three options for the basic rate. In most cases, the first option will be the called number, leaving two additional options for the customer to define. An additional six options may be purchased at an additional charge for a total of nine options per group. If more than three options are chosen, the Additional Option charges apply per additional option. Up to six additional options may be provisioned as an enhancement to the Basic service.
- e. Calls to telephone numbers associated with Custom Redirect Service must be redirected to a customer-assigned number terminating in either a customer location, an interexchange carrier's point of presence, a voice mail system, an Auto-Attendant system, or an announcement frame within the LATA of call termination. In the event the final destination is out of the LATA, the customer designates the Primary Interexchange Carrier (PIC), and the Company hands the call off to the carrier selected. A redirecting telephone number cannot be used to trigger another redirecting telephone number.
- f. It is the responsibility of the Custom Redirect customer redirecting calls to a third party to obtain, when appropriate, the third party's permission prior to the calls being redirected.
- g. Charges for calls between the Custom Redirect Service equipped telephone number and the telephone number to which these calls are redirected are the responsibility of the customer.
- h. The customer must have sufficient lines and associated facilities to handle the estimated or actual number of calls without interfering with exchange or toll service. The Company reserves the right to disconnect the service immediately in accordance with the regulations contained in the General Exchnage Tariff, Schedule D&R, Rule No. 10.

Custom Redirect Service is not to be used by customers to avoid toll charges. If a customer is using this service to avoid such charges, the Company reserves the right to disconnect the service immediately and bill all appropriate toll charges.

- i. Custom Redirect Service is not to be used by customers to avoid toll charges. If a customer is using this service to avoid such charges, the Company reserves the right to disconnect the service immediately and bill all appropriate toll charges.
- j. Term Option

Customers with more than 500 lines provisioned may choose a five-year term option for a lower monthly line rate. If the customer terminates service prior to the anniversary date of the term commitment plan, termination liability charges will apply.

<sup>1</sup> 5ESS<sup>®</sup> is a Registered Trademark of Lucent Technologies, Inc.

Effective: April 1, 2016

---

ADVANCED INTELLIGENT NETWORK (AIN) SERVICES

A. CUSTOM REDIRECT SERVICE (Continued)

3. SPECIAL CONDITIONS (Continued)

k. Minimum Period

A twelve-month minimum subscription period is applicable to Custom Redirect Service. If service is cancelled prior to the initial twelve-month subscription period, the full monthly rate for each remaining month, or part thereof, will be charged. Changes to the original configuration shall not constitute a cancellation.

l. Termination Liability

(1) Month-to-Month

Customer shall be liable for the full monthly rate for the minimum period of 12 months. If service is terminated prior to the initial twelve-month minimum subscription period, charges as specified in 3.k will apply to the remainder of the twelve-month period.

(2) Term Option

If service is terminated prior to the initial twelve-month minimum subscription period, the customer shall be liable for the full monthly rate for the remainder of the twelve-month period. For years two through five of the term commitment plan, the customer may either change to the month-to-month option or pay termination liability charges as specified in Section 2 of this Product Guide, will apply for the remainder of the term commitment plan.

If service is terminated after the initial twelve-month minimum subscription period, but prior to the anniversary date of the term commitment plan, termination liability charges as specified in Section 2 of this Product Guide, will apply to the remainder of the term commitment plan.

m. Initial Average Monthly Query Volumes are estimates only. After installation, Frontier will periodically and at its discretion, complete audits of numbers of queries. Billing will be corrected if necessary to make adjustment to the monthly charges based upon the results of the audit.

Effective: April 1, 2016

---

ADVANCED INTELLIGENT NETWORK (AIN) SERVICES

A. CUSTOM REDIRECT SERVICE (Continued)

4. APPLICATION OF RATES AND CHARGES

a. Service Establishment Charge

Charges will apply for the original order for Custom Redirect Service per Service Order or per Account. This charge will apply to New Orders of Custom Redirect Service. If a customer is modifying the existing order, including adding additional numbers, the Rearrangement Charge would apply. The addition of a new group, or a request for additional security forms, will result in a Service Establishment Charge.

b. Equipped Number

There will be a monthly rate, in addition to a nonrecurring charge, for each equipped telephone number. The Feature Per Equipped Telephone Number charge will be based on the quantity of equipped telephone numbers within the customer's account. In addition to the monthly rate, a nonrecurring charge will apply to each number installed.

c. Average Monthly Group Volume Charge (Queries per Month, per Group)

A monthly rate, in addition to a nonrecurring charge, will apply for each group of equipped telephone numbers the customer designates. The monthly rate will be based on the estimated monthly volume of queries expected by the equipped telephone numbers. A query is launched to the AIN database when a central office trigger is encountered. In basic implementations, query volume is equal to the call volume. As enhancements to the call processing logic are added and additional central office triggers placed, the query volume may exceed the call volume, resulting in an increase in the Average Monthly Group Volume Charge.

d. Rearrangement Charge

A nonrecurring charge will apply to each rearrangement. This is in addition to normal service order charges from Section 3 of this guide. Each change to an equipped telephone number will result in a nonrecurring charge for each equipped telephone number impacted. If a customer is modifying existing Custom Redirect Service, including adding additional numbers, the Rearrangement Charge applies.

e. Password Initialization

Once service is established, this nonrecurring charge applies each time the customer requests the Company to reinitialize the pass code to the default pass code or to modify existing security profiles. A service order will be generated after the initialization takes place and a Subsequent Order charge from Section 3, Service Charges will also apply.

Effective: April 1, 2016

---

ADVANCED INTELLIGENT NETWORK (AIN) SERVICES

A. CUSTOM REDIRECT SERVICE (Continued)

4. APPLICATION OF RATES AND CHARGES (Continued)

f. Redirection Charges

There is no charge associated with modifying the active option. Customers may select to activate options as frequently as desired. When calls are redirected, the Custom Redirect customer will pay the portion of the call from the original called central office to the terminating number. The rate charged will be in accordance with the customer's current usage plan similar to a call transfer or a call forward.

g. Redirecting Telephone Number

A monthly rate and a nonrecurring installation charge will apply to each assigned telephone number that will be used solely for the purpose of provisioning Custom Redirect Service. This telephone number will have no central office equipment associated with it and will be used solely for the purposes of generating a central office trigger.

h. Additional Option Charge

The basic monthly recurring charge for Custom Routing Service includes up to three basic options per group. A customer may add up to six additional options, for a total of nine per group. The Additional Option Charge and specific feature charges would apply per each option.

i. Optional Feature Charges

(1) Alternate Central Office Triggers

A nonrecurring charge will apply at the time of the establishment of the central office triggers, and a flat monthly rate will be billed for each NPA-NNX trigger in each central office switch in which a trigger is placed.

(2) Custom Applications

A nonrecurring charge will apply at the time of the establishment of this feature, and a flat monthly rate will be billed for each option with this feature.

(3) Number Identification Redirection

A monthly rate and a nonrecurring charge will apply for the first 100 telephone numbers listed for Number Identification Redirection. Each additional 100 numbers, or fraction thereof, will incur a nonrecurring charge and a monthly recurring charge.



Effective: April 1, 2016

---

ADVANCED INTELLIGENT NETWORK (AIN) SERVICES

A. CUSTOM REDIRECT SERVICE (Continued)

4. APPLICATION OF RATES AND CHARGES (Continued)

i. Optional Feature Charges (Continued)

(4) Percentage Redirection

A nonrecurring charge will apply at the time of the establishment of this feature, and a flat monthly rate will be billed for each option with this feature.

(5) Single Number Destination Service

A monthly and nonrecurring charge will apply for each group on which this feature is ordered.

(6) Special Custom Redirect Service Transaction

This rate element will allow customers to request services required on a one-time effort basis, such as the generation of a special report, out-of-hours programming support for testing, or other special handling that was not included in the rate development for Custom Redirect Service. Should the customer elect to go forward with the transaction developed, charges will be applied on an Individual Case Basis (ICB).

(7) SuperGroups

A nonrecurring charge will apply at the time of the establishment of this feature, and a flat monthly rate will be billed for each group with this feature.

(8) Time-of-Day/Day-of-Week Redirection

A nonrecurring charge will apply at the time of the establishment of this feature, and a flat monthly rate will be billed for each option with this feature.

Effective: April 1, 2016

ADVANCED INTELLIGENT NETWORK (AIN) SERVICES

A. CUSTOM REDIRECT SERVICE (Continued)

5. RATES AND CHARGES

	<u>Nonrecurring Charge</u> <sup>1</sup>	<u>Monthly Rate</u>
a. Service Establishment Charge	\$500.00	--
b. Equipped Number - per Telephone Number		
(1) <u>Month-to-Month Option</u>		
1 - 50	2.35	\$2.50
51 - 100	2.35	2.35
101 - 500	2.35	2.00
501 - 1,000	2.35	1.50
Over - 1,000	2.35	1.10
(2) <u>Term Option</u> <sup>2</sup>		
Five-Year Term, Minimum 500 Lines	2.35	1.10
c. Average Monthly Group Volume Charge, Queries per month, per group		
Up to 1,000	50.00	25.00
Up to 10,000	50.00	80.00
Up to 25,000	50.00	150.00
Up to 50,000	50.00	280.00
Up to 75,000	50.00	425.00
Up to 100,000	50.00	550.00
Up to 250,000	50.00	1,300.00
Up to 500,000	50.00	2,500.00
Up to 750,000	50.00	3,600.00
Up to 1,000,000	50.00	4,500.00
Over 1,000,000	50.00	<sup>3</sup>

<sup>1</sup> Appropriate Service Order Charges as set forth in Section 3 will apply.

<sup>2</sup> See Special Conditions, A.3.I. for termination liability charges.

<sup>3</sup> The monthly rate is determined by adding the rate for 1,000,000 plus the rate associated with the appropriate increment less than 1,000,000.

Effective: April 1, 2016

ADVANCED INTELLIGENT NETWORK (AIN) SERVICES

A. CUSTOM REDIRECT SERVICE (Continued)

5. RATES AND CHARGES(Continued)

	<u>Nonrecurring Charge</u> <sup>1</sup>	<u>Monthly Rate</u>
d. Rearrangement Charge, per occasion	\$250.00	--
per number	2.35	--
e. Password Initialization, per occasion	50.00	--
f. Redirection Charges (no charge)		
g. Redirecting Telephone Number	5.00	\$1.00
h. Additional Option Charge, per Option (when four or more are chosen)	200.00	25.00
i. Optional Feature Charges		
(1) Alternate Central Office Triggers per trigger, per switch	500.00	1.00
(2) Custom Applications, per option	200.00	25.00
(3) Number Identification Redirection First 100 Numbers	500.00	50.00
Additional 100 Numbers	100.00	10.00
(4) Percentage Redirection	100.00	25.00
(5) Single Number Destination Service, per group	50.00	10.00
(6) Special Custom Redirect Service Transaction	100.00	--
(7) SuperGroups, per group	50.00	1.00
(8) Time-of-Day/Day-of-Week Redirection	100.00	25.00

<sup>1</sup> Appropriate Service Order Charges as set forth in Section 3 will apply.

Effective: April 1, 2016

---

INFO CONTACT 900 & 976 SERVICES

TABLE OF CONTENTS

	<u>SHEET NO.</u>
I. INFO CONTACT 900 SERVICE	
A. Applicability	1
B. Territory	1
C. Special Conditions	1
D. Rates and Charges	12
II. INFO CONTACT 976 SERVICE	
A. Special Conditions	14
B. Rates and Charges	22

Effective: April 1, 2016

---

INFO CONTACT 900 & 976 SERVICES

I. INFO CONTACT 900 SERVICE

A. APPLICABILITY

Info Contact 900 Service is an intraLATA transport service and a Billing and Collection service for Information Providers and/or Sponsors other than those who provide information services of "harmful matter". Billing and Collection service for providers of "harmful matter," as identified in California Penal Code Section 313(a), is a matter for contractual arrangement between the Information Provider and/or Sponsor and the Company, and is not subject to the terms of this guide. Service is intended to be the exclusive means by which an Information Provider can obtain transport service for purposes of providing information services. The Company will bill the Information Provider and/or Sponsor transport charges based on total connection time per call, and Billing and Collection charges on a per call basis.

B. TERRITORY

Info Contact 900 Service will be offered only where call blocking (see Section 7 of this Product Guide) is available. Info Contact 900 Service will be provided over facilities within the Company's serving exchange areas. Transport charges will only be applicable to qualifying calls placed from a LATA of the Company to a number within the same LATA and transported by the Company.

The following prefixes are available for California 900 services as provided by Pacific Bell:

900-Area Code

- 844 - Recorded program general audience programs
- 505 - Live program general audience programs
- 303 - Recorded and live programs containing harmful matter

C. SPECIAL CONDITIONS

1. Company Obligations

a. General

- (1) The limitation of the Company's liability is set forth in Section 2 of this Product Guide. The Company will disconnect any Information Provider's and/or Sponsor's 900 Program for the Information Provider's and/or Sponsor's failure to comply with any provision(s) of this Product Guide or any tariff of the Company.
- (2) The Company will provide a period of 18 seconds for delayed timing of information and transport charges. If a caller hangs up within this 18 second period, no information charge will be billed to the caller and no transport charge will be billed to the Information Provider and/or Sponsor for that call. If the caller does not hang up the information and transport charges will be billed from the time of initial connection. Any call to an Info Contact 900 Information Provider's and/or Sponsor's Program which is completed and is over 18 seconds in duration is a "qualifying call."
- (3) Blocking is available to the Company's customers, under the terms and conditions set forth in Section 7 of this Product Guide, Custom Calling Services.
- (4) An Information Provider's and/or Sponsor's offering of any particular information service shall not preclude the Company from providing Info Contact 900 Service Transport to another Information Provider and/or Sponsor offering the same or similar services.

---

INFO CONTACT 900 & 976 SERVICES

I. INFO CONTACT 900 SERVICE (Continued)

C. SPECIAL CONDITIONS (Continued)

1. Company Obligations (Continued)

a. General (Continued)

- (5) Info Contact 900 Service calls billed to a Company calling card, third party calls billed to Info Contact 900 Service telephone numbers, and collect calls to Info Contact 900 Service numbers are denied. All calls to a Info Contact 900 Service number from coin telephones and all calls requiring Company operator assistance or handling are denied.

Upon termination or discontinuance of a 900 program in all LATAs, the telephone number for such program may be reassigned at the Company's discretion.

An Information Provider's and/or Sponsor's program must be similar in content in different LATAs if using the same telephone number. The Company will not assign the same telephone number to different Information Providers and/or Sponsors in different LATAs.

The Company may monitor all 900 Programs without advance notification to the Information Provider and/or Sponsor.

- (6) Billing and collection by the Company for services rendered to or for Information Providers and/or Sponsors engaged in furnishing any live or recorded videotex or audio information which contains harmful matter as defined in California Penal Code Section 313(a) is a matter for contractual arrangement between the Information Provider and/or Sponsor and the Company, and is not subject to the terms of this guide.
- (7) The Company will provide, where conditions permit, Billing and Collecting Service containing neither fewer nor more than the following elements:
- (a) Call Recording - The recording of completed calls to a specific (900) XXX-XXXX number.
  - (b) Message Processing - The transformation of recorded call detail into rated calls in preparation for billing of those calls.
  - (c) Bill Processing and Collection (with inquiry) - The preparation of bills and subsequent collection of payment by subscribers to Info Contact 900 Services. The Company will be responsible for all matters concerning billing, collection, adjustment, and call investigation.
- (8) The Company will bill and collect only for charitable contributions, information, or communication services provided over the telephone. The Company will not bill or collect for goods and services that are not provided over the telephone.
- (9) After supersedure of service, the 900 Information Provider and/or Sponsor must wait 90 days to make a telephone number change. Additionally, after a telephone number change, the 900 Information Provider and/or Sponsor must wait 90 days before placing an order to supersede their service.

Effective: April 1, 2016

---

INFO CONTACT 900 & 976 SERVICES

I. INFO CONTACT 900 SERVICE (Continued)

C. SPECIAL CONDITIONS (Continued)

1. Company Obligations (Continued)

b. Info Contact 900 Service

(1) Because the Company's capacity in central office equipment and network facilities to furnish Info Contact 900 Service Transport is limited:

(a) Info Contact 900 Service Transport will only be furnished where the Company's facilities and operating conditions permit. Info Contact 900 Service calls will be transmitted to the extent such facilities and operating conditions allow.

(b) If the Company has reason to believe that permitting the commencement or continuation of an Information Program in this Product Guide is adversely affecting or would adversely affect the Company's ability to provide, complete or maintain the level of or quality of its exchange telephone customers, the Company may refuse to provide Information Programs or may discontinue providing such service. Unless, in the judgement of the Company an emergency condition exists or is threatened, the Company shall give 24 hours notice of discontinuance. Where such emergency conditions exist or is threatened the Company may discontinue the Information Program and shall give notice of discontinuance as promptly as reasonably possible.

Info Contact 900 access lines are provided as inward only service in LATA 11.

Temporary service, as defined in the General Exchange Tariff, Schedule D&R, Rule 28, is not offered with Info Contact 900.

(2) The advance payment and deposit requirements, as set forth in the General Exchange Tariff, Schedule D&R, Rules No. 5, 6, and 7, are applicable to Info Contact 900 Service.

(3) Miscellaneous Billing Service as defined in Section 6, General Services, is not offered with Info Contact 900 Service.

(4) Late Payment Charges, as defined in the General Exchange Tariff, Schedule D&R, Rule 9, will apply to all Info Contact 900 Service.

(5) The Company does not guarantee the quality of performance of data transmission over facilities used for Info Contact 900 Service.

---

INFO CONTACT 900 & 976 SERVICES

I. INFO CONTACT 900 SERVICE (Continued)

C. SPECIAL CONDITIONS (Continued)

1. Company Obligations (Continued)

c. Notification of Subscribers

- (1) The Company will notify subscribers of California 900 information charges under the following conditions:
  - (a) Lifeline subscribers whose California 900 and 976 information charges exceeded \$30.00 for the first time.
  - (b) Subscribers whose California 900 and 976 information charges for the first time exceed \$75.00 during the course of a single billing cycle.
  - (c) Subscribers whose California 900 and 976 information charges exceed \$150.00 in a single billing cycle.
  - (d) If the Company determines a caller is generating high 900 usage, the Company may contact the caller of such charges for early notification.
- (2) When contact is made, the Company shall inform the subscriber of the charges and of blocking options. If contact cannot be made under 1.c.(1)(c), the Company shall temporarily block California 900 calls until it has made contact with the subscriber, informed the subscriber of the charges and determined if the subscriber desires to resume service.

2. Information Provider and/or Sponsor Obligations

a. General

- (1) The Information Provider's and/or Sponsor's Programs and the promotion and provision thereof must comply with all applicable Federal, State and Local laws, rules and regulations.
- (2) The Information Provider and/or Sponsor shall be liable for and shall indemnify, defend, protect and save harmless the Company against any and all losses, claims, demands, suits, causes of action, damages, costs or liability in law or in equity of every kind and nature whatsoever, including attorney's fees, arising directly or indirectly from the service or in connection therewith, including but not limited to any loss, damage, expense, or liability resulting from any infringement or claim of infringement of any patents, trademarks, or copyright, or resulting from any claim of libel or slander.
- (3) The Information Provider and/or Sponsor gives permission to the Company to release the Information Provider's and/or Sponsor's name, complete mailing address, and business telephone number to any Callers in response to inquiries or complaints. Disputes or questions concerning the nature or quality of the service or system will be referred by the Company to the Information Provider and/or Sponsor.
- (4) In accordance with the California Public Utilities Code 2884.5, caller access to programs providing messages the containing harmful matter must be furnished by the Information Provider and/or Sponsor on a subscription basis only.



Effective: April 1, 2016

---

INFO CONTACT 900 & 976 SERVICES

I. INFO CONTACT 900 SERVICE (Continued)

C. SPECIAL CONDITIONS (Continued)

2. Information Provider and/or Sponsor Obligations (Continued)

b. Info Contact 900 Facilities

- (1) The Information Provider and/or Sponsor is financially responsible for any and all costs and expenses involved in providing the programs, including, but not limited to, the Information Provider's and/or Sponsor's premises equipment, program development, advertising, and promotional expenses

Prior to installation of Info Contact 900 access lines, for Company exchange toll network sizing and protection, each Information Provider and/or Sponsor must furnish the Company an estimate of the monthly call volumes for each service area, expected average busy hour(s), busy hour call volumes, and holding times. If the Information Provider and/or Sponsor fails to do this, the Company will not establish the Information Provider's and/or Sponsor's program.

The Information Provider's and/or Sponsor's premise equipment shall be interconnected in accordance with the General Conditions and applicable rates as set forth in the General Exchange Tariff, Schedule D&R, Rule No. 34, Customer-Provided Facilities Connected to Company Exchange Facilities. If the Information Provider and/or Sponsor violates this requirement, the Company shall disconnect the Information Provider's and/or Sponsor's program.

The Information Provider and/or Sponsor is required to subscribe to access facilities capable of supporting a minimum of two simultaneous connections for each Program. The Information Provider and/or Sponsor is required to subscribe to as many additional access facilities as, in the judgement of the Company, are required to adequately handle calls without impairing service to others. If the Information Provider and/or Sponsor violates this requirement, the Company shall disconnect the Information Provider's and/or Sponsor's Program.

c. Information Programs

- (1) The Information Provider and/or Sponsor has exclusive responsibility and control over the content, quality transmission, and characteristics of programs or conversations conducted on the Information Provider's and/or Sponsor's equipment. The Company assumes no liability for the quality, defects in, or content of programs or conversations. The Information Provider and/or Sponsor shall exclude from programs or conversations any matter, the dissemination of which is prohibited by law, or by rules, regulations or order of any governmental agency.
- (2) The Information Provider and/or Sponsor shall submit to the Company all advertising, sales promotion and other publicity relating to the subject matter of their program wherein the Company's name is mentioned or language, signs, markings or symbols are used from which the connection of the Company's name therewith may be in the Company's judgement, reasonably inferred or implied, and further, the Information Provider and/or Sponsor shall not publish or use such advertising, sales promotion or publicity matter without the prior written approval of the Company.

Effective: April 1, 2016

---

INFO CONTACT 900 & 976 SERVICES

I. INFO CONTACT 900 SERVICE (Continued)

C. SPECIAL CONDITIONS (Continued)

2. Information Provider and/or Sponsor Obligations (Continued)

c. Information Programs (Continued)

- (3) The information Provider and/or Sponsor must establish the Information Charge for the Company to bill the Subscriber for qualifying calls. The Sponsor may establish initial minute charges different from subsequent minute charges. The initial minute charge can range from \$0.00 to \$5.00. The zero rate is only applicable if the program is designed to be longer than one minute in length and subsequent minutes are rated at a minimum of \$.05 per minute. Subsequent minute charges can range from \$0.00 to \$2.00 on Recorded Programs, and \$0.00 to \$2.00 on Live Programs. The maximum charge per call is \$50.00. The Information charge for programming directed to persons below the age of 18 is a maximum of \$2.00 per minute and a maximum charge per call of \$4.00. All amounts must be in whole dollar and cents amounts. The Information Charge must be the same in each LATA. The Company will round fractions of minutes to the nearest whole minute prior to rating. The Information Charge established for subsequent minutes will be billed after rounding fractions of those minutes to the next minute.
- (4) The Information Provider and/or Sponsor must establish a per call charge. The minimum per call Information charge is \$0.05 and the maximum per call charge is \$50.00.
- (5) A written request from the Information Provider and/or Sponsor to change the charges and/or rate period changes being billed by the Company must be received at least 30 calendar days prior to the proposed effective date. An Information Provider and/or Sponsor will be allowed only one price change within any 30 day period. The Information Provider and/or Sponsor will also be required to place a message on the service/recording informing Callers of the new price and/or rate period and the effective date of such, commencing 5 days prior to the rate and/or rate period change and continuing 15 days after the rate and/or rate period change. The Information Provider and/or Sponsor must also discontinue use of any features that allow a Caller to override the price disclosure message during this 20 day time period.
- (6) For 900-844-XXXX telephone numbers only, the Information Provider may divide weekdays (Monday thru Friday), excluding Company holidays, into two rate periods, i.e., peak hours and non-peak hours and may establish Information Charges for each such period. The Information Provider will be allowed only one rate period change within any 30 day period. The time of day when connection actually takes place, determined by the time system - standard or daylight saving, legally or commonly in use, determines which rate applies. In cases where a message extends beyond one rate period, the connection time rate period will apply for the duration of that call. When the Information Provider establishes two rate periods, the lower of the rate period will apply to weekends and Company holidays.
- (7) One white page listing will be provided at no charge for each 900 Program per Executive Directory subscribed to by an Information Provider and/or Sponsor. Additional listings may be requested at the rates specified in Section 21, Directory Services.

Each listing must include one or more lines to advise that special charges apply; however, the actual Information Charge shall not be specified.

Effective: April 1, 2016

---

INFO CONTACT 900 & 976 SERVICES

I. INFO CONTACT 900 SERVICE (Continued)

C. SPECIAL CONDITIONS (Continued)

2. Information Provider and/or Sponsor Obligations (Continued)

c. Information Programs (Continued)

(8) For 900-844-XXXX telephone numbers only, the Information Provider may select a Free Trial period during which no Information Charges will be billed to the Subscriber. The Information Provider will continue to be billed Transport, Billing and other applicable charges. The Information Provider is limited to 30 consecutive days during which the Free Trial period may occur, and may not select the Free Trial option more than three times in any calendar year. Subscribers will still receive a line on their bill detailing calls made to programs offering a Free Trial. The Information Charge will appear as \$0.00 on the Subscriber's bill. At the time an Information Provider requests a Free Trial period, they must also specify the rates to take effect at the end of the Free Trial period. Only Non-Recurring charge for price Changes (per program, per LATA) will apply when the Information Provider selects a Free Trial period.

(9) Recorded Programs

For each call, the Information Provider must inform the Caller of the following:

- the name of the Program and the Information Charge for the call,
- minors should seek parental approval,
- if the Caller hangs up within the delayed timing period, there will be no charge for the call,
- the date the program was recorded,
- minors should be aware that the cost of the call will appear on their parent's bill.

For fundraising programs, the amount or percent going to charity must be stated. Programs that cannot be used without a directory or other instructions must disclose this information to the Caller. This message must occur at the beginning of every call and may not be longer than 15 seconds, giving the caller at least 3 additional seconds to hang up before the 18 second delayed timing period has expired. The Information Provider must provide a tone to Indicate the end of the delayed timing period. Audiotex Programs with restricted access via PIN code or special password and videotex programs are exempted from this requirement.

For videotex programs without restricted access via PIN code or special password, the initial screen must state:

- the name of the program
- the information charge for the program

The Caller must then actively enter a command to access the program. When a Caller logs off, the final screen must give the total time and charges for the session, and then disconnect the Caller.

Interactive programs must automatically disconnect a Caller after one minute of inactivity on audiotex or after five minutes of inactivity on videotex. This requirement does not apply to bridged calls.

---

INFO CONTACT 900 & 976 SERVICES

I. INFO CONTACT 900 SERVICE (Continued)

C. SPECIAL CONDITIONS (Continued)

2. Information Provider and/or Sponsor Obligations (Continued)

c. Information Programs (Continued)

(10) Live Programs

(a) The following Sponsor obligations apply to all Live Programs:

Within the first 15 seconds of a call and at least 3 seconds prior to the connection to a live conversation, the Sponsor will complete caller notification of the following:

- the name of the program;
- the Information Charge for the call;
- that a monitor will be on the line;
- that if they hang up immediately, they will not be charged;
- that minors must have parental permission (if the program is directed to minors);
- that minors should be aware that the cost of the call will appear on their parent's bill (if the program is directed to minors);
- for fundraising programs, the amount or percent going to charity must be stated.

Each Sponsor shall provide a tone or announcement at intervals of at least 5 minutes.

(b) The following Sponsor obligations apply to all Live group conversations with the capability to bridge more than one caller. The Sponsor's premise bridging equipment shall have the following capabilities:

- monitoring
- identification of disruptive callers
- disconnection of the callers
- tone insertion or announcement at regular intervals of 5 minutes or less

(11) Every advertisement or other communication which is intended to promote the Information Provider's and/or Sponsor's program shall clearly and conspicuously display and/or disclose the maximum information charge per initial and subsequent minute, or per call, whichever is applicable. In addition, all Information Provider's and/or Sponsor's advertising for a given program must display and/or provide a voice-over with the phrase "Service may not be available in some areas". Advertising for fundraising programs will state the amount of money per call which will go to the charity or fundraising cause.

Each Information Provider and/or Sponsor must provide in all television advertisements a voice-over announcement and visual display of the applicable maximum information charge per initial and subsequent minutes, or per call, whichever is applicable. In all television advertisements directed to minors, an admonition to seek parental permission before calling the California 900 numbers must also be included in a voice-over announcement.

Effective: April 1, 2016

---

INFO CONTACT 900 & 976 SERVICES

I. INFO CONTACT 900 SERVICE (Continued)

C. SPECIAL CONDITIONS (Continued)

2. Information Provider and/or Sponsor Obligations (Continued)

c. Information Programs (Continued)

(11) (Continued)

All California 900 Programs directed to minors which contain an inducement or "teaser" to call back shall include an admonition to seek parental permission before calling back and all programs encouraging a call back shall quote the maximum information charge per initial and subsequent minute, or per call, whichever is applicable.

For advertising or other communications directed to minors, the Information Provider and/or Sponsor will inform minors that they must have parental permission.

All California 900 Programs containing a cross-promotion to another Program shall include an announcement of the maximum information charge per initial and subsequent minutes or per call, whichever is applicable of the cross-promoted California 900 program, and cross-promotions directed to minors shall include an admonition to seek parental permission before calling.

Cross-promotions or referrals from General Audience programs to harmful matter programs shall not be permitted.

The Company reserves the right to require an Information Provider or Sponsor to furnish the Company with such information as the Company deems necessary regarding the content, nature and advertising of 900 program(s), in advance of the initial connection of the service or prior to any change in the general content or nature of the program(s). Any change in the general subject matter or nature of the service without adequate prior notice to the Company, or any refusal to provide the above-required information will be grounds for disconnection of the 900 Program(s).

Any violation of state, federal, or the Company's rules, terms and conditions can result in immediate disconnection of the 900 Program. The Company will attempt to provide verbal notification of the violation and disconnection within 24 hours before such disconnection.

Effective: April 1, 2016

---

INFO CONTACT 900 & 976 SERVICES

I. INFO CONTACT 900 SERVICE (Continued)

C. SPECIAL CONDITIONS (Continued)

3. Payment of Charges

- a. The Company will bill the Information Provider and/or Sponsor per month, per program, the total number of qualifying Info Contact 900 usage minutes times the applicable Company's associated transport charges and, if applicable, the total number of qualifying Info Contact messages times the Billing and Collection charge, plus any applicable late payment charge and any nonrecurring and/or recurring charges, in addition to any applicable state, federal or local taxes and/or surcharges.
- b. Calls which connect to the Information Provider's and/or Sponsors Program, but which disconnect within the "Delayed Timing Period" will not be billed to the Information Provider and/or Sponsor.
- c. Applicable payment procedures, as set forth in the General Exchange Tariff, Schedule D&R, Rule 9, shall apply.
- d. Remittance to the Information Provider and/or Sponsor is based upon the total number of California 900-XXX-5689 (excluding 900-303-5689) completed calls which are qualifying. A qualifying call is any call which is billed by the Company with the Information Provider's and/or Sponsor's designated information charge.

The following are non-qualifying types of calls and the Company will attempt to restrict such calls from connecting to California 900 telephone numbers;

- Third party calls billed third party to California 900 telephone numbers
- Collect calls
- Calls requiring time and charges quoted by the Company operator
- Calls originating from the Prison Class of Service
- Calls originating from the Company operator handled and direct dialed Mobile Class of Service
- Calls originating from the Company WATS Class of Service including Universal and Two-Way WATS
- Calls originating from the Hospital Class of Service
- Calls originating from the Hotel/Motel Class of Service
- Calls billed to Commercial Credit Cards
- Coin Sent Paid calls
- Person to Person calls handled by the Company operator
- 10XXX Calls
- Out-of-LATA calls
- Customer-owned and Company-owned Pay Telephone calls
- Cellular and other Exchange and Interexchange Carriers with whom the Company has no billing arrangement
- Third Party billed and Credit card calls charged to an account outside of the Company's territory
- Calls made through Dual Party Relay Service.

Calls in these categories which are connected, and for which the Company can bill the Subscriber, will be remitted to the Information Provider and/or Sponsor.

Where technically feasible, all calls that are connected but are not billed to the Subscriber will be categorized on the remittance invoice but will not be remitted to the Information Provider and/or Sponsor.

Subscriber adjustments granted by the Company will be subtracted from the amount remitted to the respective Information Provider and/or Sponsor.

Effective: April 1, 2016

---

INFO CONTACT 900 & 976 SERVICES

I. INFO CONTACT 900 SERVICE (Continued)

C. SPECIAL CONDITIONS (Continued)

3. Payment of Charges (Continued)

- e. The Company will recover the cost of blocking by assessing each Information Provider and/or Sponsor a charge for each minute billed to an Information Provider and/or Sponsor of California 900 Services for calls made to the Information Provider and/or Sponsor from the Company's territory.
- f. Each month the Company will bill a 5.0% cost allocation surcharge to Information Providers and/or Sponsors based on the amount calculated by multiplying the qualifying California 900 usage minutes the applicable information charges, less the utilities associated transport and billing charges, times cost allocation surcharge of 5.0%. As authorized in D.89-03-061, Frontier may request a change in the surcharge if uncollectibles are significantly different for each prefix. This change would be subject to Commission approval.

Once actual uncollectible data by the Information Provider and/or Sponsor is available, the 5.0% cost allocation surcharge will be deleted and all actual uncollectibles will be subtracted from the amount remitted to the Information Provider and/or Sponsor.

g. Adjustments

(1) Subscriber Adjustments

The Company shall make a one-time adjustment for 900 charges per subscriber account if it is established that either (1) calls were made by the subscriber's minor children without parental consent or (2) the calls were not authorized by the subscriber.

- (2) A subscriber must request an adjustment within 60 days of the bill date on the bill in question. The subscriber will be informed of the availability of Call Restriction Service, Section 6, Custom Calling Services, at the time of the adjustment. If the subscriber elects to have Call Restriction Service, contested 900 charges will be adjusted to the date blocking is placed on the subscriber's line.
- (3) The customer must establish a specific complaint procedure and an adjustment policy as defined in Decision No. 91-03-021, Attachment D. The Company will adopt the established procedure when the Company provides Billing and Collection services for the customer.
- (4) The Company may remove from the subscriber's bill any amount the subscriber disputes or refuses to pay. Subscribers are eligible for an adjustment if dissatisfied with an Information Provider's and/or Sponsor's program for any justified reason.
- (5) Before an adjustment for one hundred dollars (\$100.00) or more will be made for calls made by subscribers' minor children without parental permission, the Company shall receive a signed declaration from the Subscriber requesting an adjustment. The Company may, at its discretion, require a signed declaration for adjustments of less than one hundred dollars (\$100.00) or for other types of adjustments.

INFO CONTACT 900 & 976 SERVICES

I. INFO CONTACT 900 SERVICE (Continued)

C. SPECIAL CONDITIONS (Continued)

4. Discontinuance of Service For Nonpayment of Bills

Bills shall be considered past due (delinquent) and service to a delinquent Information Provider and/or Sponsor may be discontinued for nonpayment of the Company's bill for services furnished, provided:

- a. The bill has not been paid within thirty (30) calendar days after the date of presentation of the monthly bills.
- b. The Company first gives notice by first class mail to the Information Provider/Sponsor's address relative to delinquency and impending termination. If payment is not received by the Company within fifteen (15) calendar days of this notification, the Company may proceed with cessation of Company-provided services.
- c. The Company will not cause cessation of service on any Saturday, Sunday or legal holiday observed by the Company.

D. RATES AND CHARGES

1. Establishment of and Changes in Info Contact 900 Service

	<u>MRC</u>	<u>Nonrecurring Charge</u>
a. Establishment of Service, Reconnection or Reassignment of existing facilities to a new service, Per program		\$325.00
b. Supersedure, add, delete or change of price or telephone number, Per program		100.00
c. Info Contact 900 Access Lines, <sup>1</sup> Per line	\$25.50	<sup>2</sup>
d. Transport rates apply to the 900-XXX-XXXX calls. The transport charge is non-distance sensitive. The transport usage charges will be billed to the Information Provider and/or Sponsor.		

	<u>First Minute</u>	<u>Each Additional 30 Seconds</u> <sup>3</sup>
Transport Charge, Per call	\$.10	\$.045

<sup>1</sup> Available in LATA 11 only.

<sup>2</sup> Charges applicable as shown in Section 3, Service Charges, for Individual Business Line Service.

<sup>3</sup> After the initial 18 seconds for delayed timing, partial seconds for the first minute will be rated as a full minute. Rating for each additional period will be done in 30 second increments. Partial second charges for each additional period will be rounded off to the next half minute.



Effective: April 1, 2016

---

INFO CONTACT 900 & 976 SERVICES

I. INFO CONTACT 900 SERVICE (Continued)

D. RATES AND CHARGES (Continued)

2. Allocation of blocking costs <sup>1</sup>

Each Billed Minute  
or Fraction Thereof

\$ .02

3. Billing and Collecting all (900)XXX-XXXX Telephone Numbers except (900)303-XXXX. The Billing and Collection charge will be billed to the Information Provider and/or Sponsor.

Provider Charge per Total Individual Call  
\$0.05 - \$0.50      \$0.51 - \$2.00      \$2.01 - \$50.00

Billing and Collection Rate,  
Per Message

\$0.08

\$0.15

\$0.25

<sup>1</sup> As authorized in Decision 91-04-031.

Effective: April 1, 2016

---

INFO CONTACT 900 & 976 SERVICES

II. INFO CONTACT 976 SERVICE

A. SPECIAL CONDITIONS

1. Description of Service

- a. Info Contact 976 Service consists of service and facilities for customer provided pre-recorded announcements or interactive programs. This service enables a caller, for a charge, to dial a Info Contact 976 Service telephone number and receive a Info Contact 976 Service Provider's recorded announcement or interactive program. As a part of this service the Company will transport calls and bill callers on behalf of the Info Contact 976 Service Provider. Each completed call to an Info Contact 976 Service number will be made at a charge to the caller.
- b. An interactive program is a program whereby a caller through the use of a touch call pad or similar device can communicate with the Info Contact 976 Service Provider equipment for the purpose of sending or receiving information.

2. An Information Provider and/or sponsor is a person providing Pay-Per-Call Services who wishes the Company to bill callers on its behalf for all calls completed to the Provider's announcement or interactive program and for whom the Company agrees to provide such billing. A caller to a 976 number is a client of the Information Provider and/or 976 Program sponsor.

"Pay-Per-Call" services are telecommunications services which permit simultaneous calling by a large number of callers to a single telephone number and for which the calling party is assessed, by virtue of completing the call, a charge that is not dependent on the existence of a presubscription relationship and for which the caller pays a per-call or per-time-interval charge that is greater than, or in addition to, the charge for transmission of the call.

3. General

- a. Because the capacity of central office equipment and network facilities to furnish Info Contact 976 Service is limited:
  - (1) Service will only be furnished where facilities and operating conditions permit.
  - (2) If the Company has reason to believe that permitting the commencement or continuation of the 976 Program under this Product Guide is adversely affecting or would adversely affect the Company's ability to provide complete or maintain the level of or quality of its other services to its other subscribers, the Company may refuse to provide Info Contact 976 Service or may discontinue providing such service. Unless, in the judgement of the Company, an emergency condition exists or is threatened, the Company shall give 24 hours notice of discontinuance. Where such emergency condition exists or is threatened, the Company shall give notice of discontinuance as promptly as reasonably possible.
- b. The Info Contact 976 Service Provider must ensure that the Info Contact 976 Service Provider program does not provide messages containing harmful matter as defined in California Penal Code Section 313(a). The Company provides a separate prefix for programs containing harmful matter in this section, under Info Contact 900 Service.

Effective: April 1, 2016

---

INFO CONTACT 900 & 976 SERVICES

II. INFO CONTACT 976 SERVICE (Continued)

A. SPECIAL CONDITIONS (Continued)

3. General (Continued)

- c. Info Contact 976 Service Provider sponsorship of any particular recorded announcement or interactive program shall not preclude the Company from providing service to another Info Contact 976 Service Provider sponsoring the same or similar announcement or program.
- d. The Info Contact 976 Service Provider shall indemnify and defend the Company against and hold the Company harmless from any and all losses, claims, demands, causes of action, damages, costs or liability in law or inequity of every kind and nature whatsoever, including attorney fees, arising directly or indirectly from material transmitted, and from any act or omission of the Provider or Caller while using or attempting to use Info Contact 976 Service said service and facilities.
- e. The limitation of the Company's liability is set forth in Section 2 of this Product Guide.
- f. Info Contact 976 Service access lines are provided as inward only service in LATA 5, Westminster Extended Info Contact 976 Service Calling Area.

Temporary service, as defined in the General Exchange Tariff, Schedule D&R, Rule 28, is not offered with Info Contact 976 Service.

- g. One Executive Directory listing per announcement or program will be furnished without charge in each directory within an Info Contact 976 Service Calling Area. Directory listings for Info Contact 976 Service must specify that additional charges apply to calls placed to a listed number.
- h. Each directly dialed sent paid call (toll or local), will be at a predetermined amount established by Info Contact 976 Service Provider plus any other appropriate rate. Any request by the Info Contact 976 Service Provider for a change in the amount the Company is to bill per call must be received by the Company in writing, at least 30 days prior to the proposed effective date.
- i. Directly dialed sent paid calls from flat or measured rate access lines within the Info Contact 976 Service Calling Area do not incur message unit or Zone Calling unit charges, nor are they included in local flat rate service charges.

Effective: April 1, 2016

---

INFO CONTACT 900 & 976 SERVICES

II. INFO CONTACT 976 SERVICE (Continued)

A. SPECIAL CONDITIONS (Continued)

3. General (Continued)

- j. Remittance to the Information Provider and/or Sponsor is based upon the total number of California 976-XXX-5689 completed calls which are qualifying. A qualifying call is any call which is billed by the Company with the Information Provider's and/or Sponsor's designated information charge.

The following are non-qualifying types of calls and the Company will attempt to restrict such calls from connecting to California 976 telephone numbers:

- Third party calls billed third party to California 976 telephone numbers
  - Collect calls
  - Calls requiring time and charges quoted by the Company operator
  - Calls originating from the Prison Class of Service
  - Calls originating from the Company operator handled and direct dialed Mobile Class of Service
  - Calls originating from the Company WATS Class of Service including Universal and Two-Way WATS
  - Calls originating from the Hospital Class of Service
  - Calls originating from the Hotel/Motel Class of Service
  - Calls billed to Commercial Credit Cards
  - Coin Sent Paid calls
  - Person to Person calls handled by the Company operator
  - Out-of-LATA calls
  - Customer-owned and Company-owned Pay Telephone calls
  - Cellular and other Exchange and Interexchange Carriers with whom the Company has no billing arrangement
  - Third Party billed and Credit card calls charged to an account outside of the Company's territory
  - Calls made through Dual Party Relay Service.
  - 10XXX Calls
- k. The minimum length of each message shall be 78 seconds or one complete cycle of a 60 second message, a 15 second disclosure message, and 3 seconds for the caller to hang up if they do not wish to complete the call. Following the initial 78-second message, message length may be increased in 30 second increments. Total length of a message shall never exceed 198 seconds. If the agreed upon message length is more than 78 seconds, the Info Contact 976 Service Provider will pay the additional time rate. The provider must notify the Company whenever the message length is to be increased or decreased.

If the message length is longer than that agreed upon, the Company may terminate the service.

Effective: April 1, 2016

---

INFO CONTACT 900 & 976 SERVICES

II. INFO CONTACT 976 SERVICE (Continued)

A. SPECIAL CONDITIONS (Continued)

3. General (Continued)

- I. Within the first 15 seconds of a call and prior to the connection to a Info Contact 976 Service program, the Information Provider will notify the caller of the following:

(1) Specific information stating:

- (a) The name of the program.
- (b) The information charge for the call.
- (c) The date the information was recorded, if the information is a recorded message.
- (d) If the caller disconnects the call within the delayed timing period, the caller will not be charged for the call.
- (e) That minors must have parental permission (if the program is directed to minors).
- (f) That minors should be aware that the cost of the call will appear on their parent's bill (if the program is directed to minors).
- (g) That minors should hang up if the program is adult in nature.
- (h) Any additional charges that the caller must incur to obtain the full information or service.
- (i) The dollar amount (or percent of the total price of the call) that will go to which charity, if an Information Provider and/or sponsor is fund raising.

- (2) At least three seconds at the end of the message within the delayed timing period for the caller to hang up without being charged if he or she has not already disconnected the call.

The customer shall not be billed for any calls that are disconnected within the delayed timing period. If the delayed timing period is exceeded, the caller will be billed from the time of the initial connection, and transport charges shall be billed to the information provider from the time of initial connection.

- m. If the service is disconnected, all remittance money due to the Info Contact 976 Service Provider may be credited or applied to the final bill issued for the recurring charges associated with this service, or for the facilities provided to connect the customer's premises equipment to the serving central office.
- n. Upon termination of an Info Contact 976 Service, the Info Contact 976 Service telephone number will not be reassigned for at least six (6) months.
- o. The Info Contact 976 Service Provider is responsible for provision of the recorded announcement or interactive program and all necessary customer premises equipment.
- p. The Info Contact 976 Service Provider provided automatic announcement equipment will be of a design which automatically disconnects after playing out one full cycle of the message.
- q. The Info Contact 976 Service Provider provided equipment will be furnished in accordance with the conditions and applicable rates as set forth in Schedules Cal. P.U.C. No. D&R, Rule 34 and Section 6 of this Product Guide.

Effective: April 1, 2016

---

INFO CONTACT 900 & 976 SERVICES

II. INFO CONTACT 976 SERVICE (Continued)

A. SPECIAL CONDITIONS (Continued)

3. General (Continued)

- r. The Info Contact 976 Service Provider established call rate will not be less than \$0.20 or more than \$2.00.
- s. The name, address and telephone number for inquiries of information providers which have billing and transport arrangements with the Company may be released to callers upon request. The Company may, at its discretion and if the information is available, release the same information for providers with whom it does not have billing and transport arrangements.
- t. The Company will immediately terminate service to any Info Contact 976 Service Provider for fraud or unlawful business practices.
- u. The Company will provide, where conditions permit, Billing and Collecting Service containing neither fewer nor more than the following elements:
  - (1) Call Recording - The recording of completed calls to a specific 976 number.
  - (2) Message Processing - The transformation of recorded call detail into rated calls in preparation for billing of those calls.
  - (3) Bill Processing and Collection (with inquiry) - The preparation of bills and subsequent collection of payment by subscribers to Information Services. The Company will be responsible for all matters concerning billing, collection, adjustment, and call investigation.

4. Info Contact 976 Service Provider Obligation

- a. The Provider will provide continuous uninterrupted automatic recorded announcement or interactive program service.
- b. The Provider is responsible for the preparation and recording of all announcements and shall be solely responsible for the contents of the announcements and the quality of speech or sounds of the recording.
- c. The Provider understands and agrees that all announcements must comply with the Federal, State and Local laws, rules and regulations.
- d. Each Provider advertisement, publication or other communication continuing the Info Contact 976 Service telephone number to be called shall clearly and conspicuously display the Info Contact 976 Service Calling Area, what the per call rate is for directly dialed calls from within that area and that calls from outside the area will be at normal toll rates plus the Info Contact 976 Service call rate.

In addition, all television advertisements must include a voice-over announcement of the price of the 976 Call and, in those advertisements directed to minor children, an admonition to seek parental permission before calling the 976 number.

All Info Contact 976 Service programs directed to minor children which contain an inducement or "teaser" to call back shall include an admonition to seek parental permission before calling back and indicate charges are involved in making the call. All Info Contact 976 Service programs containing a cross-promotion to another recording shall include an announcement of the price of the cross-promoted Info Contact 976 Service call.

Effective: April 1, 2016

---

INFO CONTACT 900 & 976 SERVICES

II. INFO CONTACT 976 SERVICE (Continued)

A. SPECIAL CONDITIONS (Continued)

4. Info Contact 976 Service Provider Obligation (Continued)

- e. The Provider assumes all financial responsibility for all costs involved in providing announcements or interactive program services including but not limited to, the customer premises equipment, producing the announcement or interactive program development, advertising and promotional expense.
- f. For exchange toll network sizing and protection, each Provider must provide the Company with an estimate of annual call volumes, the expected busy hour and busy hour call volumes and message lengths for each announcement or interactive program.
- g. The Provider assumes, according to other specific rates and charges in this guide, all financial responsibility for all facilities required to connect the equipment located on the customer's premises to the central office which serves the particular prefix code used for Info Contact 976 Service.

5. Company's Obligation

- a. On behalf of the Info Contact 976 Service Provider, the Company will bill the Provider's clients (Callers) for all directly dialed sent paid calls completed to the announcement or program from flat and measured rate access lines.
- b. The one-time adjustment per subscriber shall apply to 976 charges incurred when it is established that (1) for calls by a minor child, the calls were made by the minor child without parental consent, or (2) the calls were not authorized by the subscriber. The subscriber must request an adjustment within 60 days of the bill date on the bill in question. These adjustments apply to the vendor charge only. Toll/ZUM charges shall not be included in the adjustment.
- c. The Provider must establish a specific complaint procedure and an adjustment policy as defined in Decision No. 91-03-021, Attachment D. The Company will adopt the established procedure when the Company provides Billing and Collection services for the Provider.
- d. The Company may remove from the subscriber's bill any amount the subscriber disputes or refuses to pay. Subscribers are eligible for an adjustment if dissatisfied with an Information Provider's and/or Sponsor's program for any justified reason.
- e. The Company may block access to Info Contact 976 Service for subscribers who fail or refuse to pay Info Contact 976 Service charges (except for charges for which an adjustment is granted.)
- f. The Company shall obtain a signed declaration from a subscriber requesting an adjustment of one hundred dollars (\$100.00) or more. The Company may, at its discretion, obtain a signed declaration for adjustments of less than one hundred dollars (\$100.00).

Effective: April 1, 2016

---

INFO CONTACT 900 & 976 SERVICES

II. INFO CONTACT 976 SERVICE (Continued)

A. SPECIAL CONDITIONS (Continued)

5. Company's Obligation (Continued)

- g. The Company will issue a remittance check monthly to the Info Contact 976 Service Provider based on the total number of directly dialed sent paid calls, completed to the Info Contact 976 Service Provider's announcement or program minus any calls adjusted by the Company.

The amount of remittance will be the difference between the Info Contact 976 Service Provider's established rate per call and the Company's Transport and Billing rate per call times the number of qualifying calls less any nonrecurring or recurring charge owed the Company by the Info Contact 976 Service Provider.

Pursuant to CPUC Decision 91-10-043, issued October 23, 1991, all one time adjustments for 976 calls made on or after November 22, 1991, pursuant to Special Condition 5.b. preceding, will be recharged net of billing and collection and transport charges to the appropriate Info Contact 976 Service Provider's account.

- h. Included with the Info Contact 976 Service Provider's monthly bill will be a summary of the number of calls on which the amount of remittance is based.

i. Notification of Subscribers

- (1) The Company will notify subscribers of California 976 information charges under the following conditions:

- (a) Lifeline subscribers whose California 976 and 900 information charges exceeded \$30.00 for the first time;
- (b) Subscribers whose California 976 and 900 information charges for the first time exceed \$75.00 during the course of a single billing cycle;
- (c) Subscribers whose California 976 and 900 information charges exceed \$150.00 in a single billing cycle.
- (d) If the Company determines a caller is generating high 976 usage, the Company may contact the caller of such charges for early notification.

- (2) When contact is made, the Company shall inform the subscriber of the charges and of blocking options. If contact cannot be made under (1)(c), the Company shall temporarily block California 976 calls until it has made contact with the subscriber, informed the subscriber of the charges and determined if the subscriber desires to resume service.



Effective: April 1, 2016

---

INFO CONTACT 900 & 976 SERVICES

II. INFO CONTACT 976 SERVICE (Continued)

A. SPECIAL CONDITIONS (Continued)

6. Info Contact 976 Service Facilities

- a. Prior to installation of Info Contact 976 Service access lines, for Company exchange toll network sizing and protection, each Information Provider and/or Sponsor must furnish the Company an estimate of the monthly call volumes for each service area, expected average busy hour(s), busy hour call volumes, and holding times. If the Information Provider and/or Sponsor fails to do this, the Company will not establish the Information Provider's and/or Sponsor's program.

The Information Provider's and/or Sponsor's premises equipment shall be interconnected in accordance with the General Conditions and applicable rates as set forth in the General Exchange Tariff, Schedule D&R, Rule No. 34, Customer-Provided Facilities Connected to Company Exchange Facilities. If the Information Provider and/or Sponsor violates this requirement, the Company shall disconnect the Information Provider's and/or Sponsor's program.

The Information Provider and/or Sponsor is required to subscribe to access facilities capable of supporting a minimum of two simultaneous connections for each Program. The Information Provider and/or Sponsor is required to subscribe to as many additional access facilities as, in the judgement of the Company, are required to adequately handle calls without impairing service to others. If the Information Provider and/or Sponsor violates this requirement, the Company shall disconnect the Information Provider's and/or Sponsor's Program.

INFO CONTACT 900 & 976 SERVICES

II. INFO CONTACT 976 SERVICE (Continued)

B. RATES AND CHARGES

1. Applicable to the Info Contact 976 Service Provider

	<u>Nonrecurring Charge</u>	<u>Monthly Rate</u>
a. Initial establishment of Info Contact 976 Service, in each area code <sup>1</sup> , on the same service order, per announcement or interactive program.	\$325.00	-
b. Any change in established call rate per announcement, interactive program, or telephone number.	100.00	-
c. Info Contact 976 Service Access Lines, <sup>2</sup> Per line	<sup>3</sup>	\$25.50

d. Transport and Billing of Calls

(1) Transport

<u>Customer Established Call Rate</u>	<u>Initial 60 Seconds</u>	<u>Each Add'l 30 Seconds or Fraction Thereof <sup>4</sup></u>
Per call	\$0.07	\$0.035

(2) Billing and Collection Service

Billing and Collection charge billed to the Info Contact 976 Service Provider.

<u>Provider Charge per Total Individual Call</u>	<u>\$0.20 - \$0.50</u>	<u>\$0.51 - \$2.00</u>
Billing and Collection Rate, Per message	\$0.08	\$0.15

<sup>1</sup> Area code in effect on January 1, 1984.

<sup>2</sup> Available in LATA 5, Westminster Extended Info Contact 976 Service Calling Area.

<sup>3</sup> Charges applicable as shown in Section 3, Service Charges, for Individual Business Line Service.

<sup>4</sup> See Special Condition 3.k. preceding.

INFO CONTACT 900 & 976 SERVICES

II. INFO CONTACT 976 SERVICE (Continued)

B. RATES AND CHARGES (Continued)

1. Applicable to the Info Contact 976 Service Provider (Continued)

	<u>Nonrecurring Charge</u>	<u>Monthly Rate</u>
e. Moves and changes, on same premises	1	1
f. Allocation of blocking costs <sup>2</sup>	<u>Each Billed Minute or Fraction Thereof</u>	
	\$.02	
g. Cost Allocation Surcharge		

Each month the Company will assess a 5% cost allocation surcharge to Info Contact 976 Service Providers based on the amount due them. This surcharge allows the Company to recover subscriber uncollectibles. Once actual uncollectible data by the Information Provider and/or Sponsor is available, the 5.0% cost allocation surcharge will be deleted and all actual uncollectibles will be subtracted from the amount remitted to the Information Provider and/or Sponsor.

2. Applicable to the Caller

a. A remittance is made to the Info Contact 976 Service Provider for the following types of calls:

<u>Type of Call</u>	<u>Rate</u>
(1) Directly-dialed sent paid calls from flat and measured rate access lines within the Info Contact 976 Service calling area, Each call	3
(2) Directly-dialed sent paid calls from flat and measured rate access lines outside the Info Contact 976 Service calling area, Each call	4

b. A remittance is **not** made to the Info Contact 976 Service Provider for the following types of calls:

- (1) Calls adjusted by the Company
- (2) Calls which are determined to be uncollectible

<sup>1</sup> Unless otherwise shown in this section, charges are applicable as shown in Section 3, Service Charges, for Individual Line Business Service.

<sup>2</sup> As authorized in Decision 91-04-031.

<sup>3</sup> A predetermined amount established by the Info Contact 976 Service Provider. The amount must be at least equal to the transport and billing rates stated in Rates and Charges, B.1.d., of this section.

<sup>4</sup> The appropriate rate for a call to an Info Contact 976 Service Provider plus the toll call rated to the appropriate toll rate center as shown under rates in Rates and Charges, B.4., of this section.

Effective: April 1, 2016

---

INFO CONTACT 900 & 976 SERVICES

II. INFO CONTACT 976 SERVICE (Continued)

B. RATES AND CHARGES (Continued)

3. Info Contact 976 Service Calling Areas

a. Covina Extended Info Contact 976 Service Calling Area

Covina	Pomona <sup>1</sup>
Monrovia	Whittier

b. Los Angeles Extended Info Contact 976 Service Calling Area

Downey	Redondo	Sierra Madre
Downey D.A.	Santa Monica	Sunland-Tujunga
Norwalk D.A.	Mar Vista D.A.	West Los Angeles
Monrovia	Santa Monica D.A.	Whittier

c. Los Gatos Extended Info Contact 976 Service Calling Area

Los Gatos	Morgan Hill
-----------	-------------

d. Palm Springs Extended Info Contact 976 Service Calling Area

Desert Hot Springs	Palm Desert	Palm Springs
--------------------	-------------	--------------

e. Sacramento Extended Info Contact 976 Service Calling Area

Meadowview	Isleton	Walnut Grove
Courtland		

f. Thousand Oaks Extended Info Contact 976 Service Calling Area

Thousand Oaks

g. Westminster Extended Info Contact 976 Service Calling Area

Huntington Beach	Long Beach <sup>2</sup>	Westminster
------------------	-------------------------	-------------

h. Fresno Extended Info Contact 976 Service Calling Area

Badger	Lindsay	Squaw Valley
Fowler	Miramonte	Strathmore
Grant Grove	Reedley	

<sup>1</sup> Limited to calls originating from the Walnut Central Office of the Pomona Exchange.

<sup>2</sup> Limited to calls originating from the Alamos, Termino, Clark and Warner Central Office areas of the Long Beach Exchange.

Effective: April 1, 2016

INFO CONTACT 900 & 976 SERVICES

II. INFO CONTACT 976 SERVICE (Continued)

B. RATES AND CHARGES (Continued)

3. Info Contact 976 Service Calling Areas (Continued)

i. San Francisco Extended Info Contact 976 Service Calling Area

Novato

j. Santa Rosa Extended Info Contact 976 Service Calling Area

Kenwood

4. Info Contact 976 Service Calling Areas Exchange Toll Rate Centers

Charges referred to under Rates comprehend calls to Info Contact 976 Service in the following Info Contact 976 Service calling area:

Info Contact 976 Service Calling Area	Area <u>Code</u>	<u>Prefix</u>	<u>Exchange Toll Rate Center</u>
Los Angeles <sup>1</sup>	818	976	Los Angeles District Area No. 1
Los Angeles	213/310	976	Los Angeles District Area No. 1
San Jose <sup>1</sup>	408	976	San Jose
San Diego <sup>1</sup>	619	976	San Diego
Sacramento	916	976	Sacramento Main District Area
Thousand Oaks <sup>2</sup>	805	976	Thousand Oaks
Westminster	714	976	Westminster
Fresno	209	976	Fresno
San Francisco	415	976	San Francisco
Santa Rosa	707	976	Santa Rosa

<sup>1</sup> NPA 818 formerly shown as Covina; NPA 619 formerly shown as Palm Springs; NPA 408 formerly shown as Los Gatos.

<sup>2</sup> Not available at this time.

Effective: April 1, 2016

---

INSIDE WIRE, INTRABUILDING CABLE, NETWORK FACILITIES AND ASSOCIATED DEMARCATION POINTS

TABLE OF CONTENTS

	<u>SHEET NO.</u>
I. APPLICABILITY	1
II. TERRITORY	1
III. RATES AND CHARGES	1
A. Intrabuilding Cable (INC)	1
B. Relocation of the Minimum Point of Entry (MPOE) / Local Loop Demarcation Point (LLDP)	4
IV. SPECIAL CONDITIONS	
A. Definitions	5
B. General	6
C. Intrabuilding Network Cable (INC)	8
D. Demarcation Points	10
E. Location of Demarcation Points on Continuous Property	12
F. Relocation of the Minimum Point of Entry (MPOE) / Local Loop Demarcation Point (LLDP)	13
G. Service Provisioning Cross Connects (SPCs)	13
H. Serving Arrangements for Property Under Development	14
I. Access to the Network	14
J. Description of Building Types, Continuous Property and Ownership	14
K. Isolation	15
L. INC Service Offerings	16

Effective: April 1, 2016

---

INSIDE WIRE, INTRABUILDING CABLE, NETWORK FACILITIES AND ASSOCIATED DEMARCATION POINTS

I. APPLICABILITY

Applicable to residential and business Basic Exchange Access Services, WATS, 800 Service, Private-Line and Special Access Services.

Special Note:

These terms and conditions define the Local Loop Demarcation Point (LLDP), the Intrabuilding Cable Demarcation Point (INCDP), and the Inside Wire Demarcation Point (IWDP) and supersede all other definitions in Frontier's General Exchange Tariff as of August 8, 1993.

II. TERRITORY

Within all exchange areas as those areas are defined on maps filed as part of the General Exchange Tariff Schedule No. AB.

III. RATES AND CHARGES

A. Intrabuilding Cable (INC)

1. Consultation and Design For New Installation and Rearrangements

a. Each hour or fraction thereof

	<u>Technician</u>	Professional Engineer
(1) Weekdays (Weekdays, except holidays 8:00 a.m. to 5:00 p.m.)	\$60.00	\$120.00
(2) After Hours (Weekdays 5:00 p.m. to 8:00 a.m. and Saturdays, except holidays)	90.00	180.00
(3) Sundays and Holidays	120.00	240.00

b. Charges for Design Materials/Drawings

Utility provided material price.  
Minimum charge is \$50.00  
(includes two copies of design)

Rate

ICB

<sup>1</sup> See Product Guide Section 3 for nonrecurring charges applicable to adding Inside Wire Maintenance (IWM) and to INC Service Agreement Plan.

Effective: April 1, 2016

---

INSIDE WIRE, INTRABUILDING CABLE, NETWORK FACILITIES AND ASSOCIATED DEMARCATION POINTS

III. RATES AND CHARGES (Continued)

A. Intrabuilding Cable (INC) (Continued)

	<u>Rate</u>
2. Installation and Rearrangements of INC	
a. Each hour or fraction thereof	
(1) Weekdays (Weekdays, except holidays 8:00 a.m. to 5:00 p.m.)	\$75.00
(2) After Hours (Weekdays 5:00 p.m. to 8:00 a.m. and Saturdays, except holidays)	112.00
(3) Sundays and Holidays	150.00
b. Utility Provided material Prices	ICB
3. Repair and Maintenance of INC	
a. Each hour or fraction thereof	
(1) Weekdays (Weekdays, except holidays 8:00 a.m. to 5:00 p.m.)	75.00
(2) After Hours (Weekdays 5:00 p.m. to 8:00 a.m. and Saturdays, except holidays)	112.00
(3) Sundays and Holidays	150.00
b. Utility Provided Material Prices	ICB
c. Service Agreement Plan <sup>1, 2, 3</sup>	
(1) Basic Repair Service	
(a) Basic Repair During Office Hours <sup>4</sup>	

An annual rate of 1.5 percent of the capital value of the Intrabuilding Cable (INC) infrastructure or a minimum of \$80.00 per year.

<sup>1</sup> See Product Guide Section 3 for nonrecurring charges applicable to adding Inside Wire Maintenance (IWM) and to INC Service Agreement Plan.

<sup>2</sup> Until August 8, 1998, monthly payment arrangements are available. Customers will be billed for a minimum of one year. Customers may cancel service with a one-month (30-day) notice given to the Utility. The account balance will be calculated based on a prorated monthly amount and refunded to the customer.

<sup>3</sup> ICB rates are applicable for customers with greater than 900 pairs or for customers who require fixed term contracts for greater than one year.

<sup>4</sup> Office Hours are 8:00 a.m. to 5:00 p.m., Monday through Friday.



Effective: April 1, 2016

INSIDE WIRE, INTRABUILDING CABLE, NETWORK FACILITIES AND ASSOCIATED DEMARCATION POINTS

III. RATES AND CHARGES (Continued)

A. Intrabuilding Cable (INC) (Continued)

3. Repair and Maintenance of INC (Continued)

c. Service Agreement Plan <sup>1,2,3</sup> (Continued)

(2) Intrabuilding Cable - Capital Value Prices <sup>4</sup>

Cable Length (ft.)	Up to 50 Pair	100 Pair	200 Pair	300 Pair	400 Pair	600 Pair	900 Pair
Up to 100	\$1,349	\$1,468	\$1,659	\$2,666	\$2,896	\$3,287	\$4,178
101 - 300	2,867	3,067	3,465	5,470	5,904	6,625	8,379
301 - 500	4,354	4,656	5,261	8,264	8,902	9,951	12,626
501 -1000	8,457	8,941	10,061	15,890	17,038	18,964	24,046
1001 -1500	12,495	13,179	14,818	23,514	25,172	27,972	35,464
1501 & longer	16,532	17,418	19,574	31,139	33,307	36,982	46,883

Rate

4. Additional Local Loop Demarcation Point (LLDP) Charge

See D&R Rule No. 27 Aerial Service Connection Facilities, or Underground Service Connections.

5. Charge for Copies of INC Charts and Diagrams

a. Utility Provided Material Prices

ICB

<sup>1</sup> See Product Guide Section 3 for nonrecurring charges applicable to adding IWMP and INC Service Agreement Plans.

<sup>2</sup> Until August 8, 1998, monthly payment arrangements are available. Customers will be billed for a minimum of one year. Customers may cancel service with a one-month (30-day) notice given to the Utility. The account balance will be calculated based on a prorated monthly amount and refunded to the customer.

<sup>3</sup> ICB rates are applicable for customers with greater than 900 pairs or for customers who require fixed term contracts for greater than one year.

<sup>4</sup> Prices listed reflect standard installation procedures and conditions for 24 gauge INC cable and apparatus only. Special applications, including but not limited to armored cable, poles, coax, utility-owned due and priced on an Individual Case Basis (ICB).

Effective: April 1, 2016

INSIDE WIRE, INTRABUILDING CABLE, NETWORK FACILITIES AND ASSOCIATED DEMARCATION POINTS

III. RATES AND CHARGES (Continued)

A. Intrabuilding Cable (INC) (Continued)

6. Flexible Rates

This section contains flexible rates for services listed below.

The rates set forth preceding may be raised (not to exceed the maximum) or lowered by the Utility with at least 30 days prior notice to the C.P.U.C. before the effective date. The current rates will be set forth on the following basis.

	<u>Maximum</u>		Rate		<u>Minimum</u>	
a. Installation, Rearrangement and Repair of INC						
(1) Each hour or fraction thereof						
(a) Weekdays			\$75.00			\$70.00
(b) After hours			112.00			105.00
(c) Sundays & Holidays			150.00			140.00
b. Service Agreement Plan						
(1) Rates			Refer to III.A.3.c			
c. Consultation and Design			Technician		Professional Engineer	
(1) Each hour or fraction thereof			<u>Max</u>	<u>Min</u>	<u>Max</u>	<u>Min</u>
(a) Weekdays			\$60.00	\$55.00	\$120.00	\$110.00
(b) After hours			90.00	83.00	180.00	165.00
(c) Sundays & Holidays			120.00	110.00	240.00	220.00

B. Relocation of the Minimum Point of Entry (MPOE) / Local Loop Demarcation Point (LLDP) on Continuous Multi-Tenant Property. (See Special Conditions F) Appropriate construction charges to be determined per project.

Effective: April 1, 2016

---

INSIDE WIRE, INTRABUILDING CABLE, NETWORK FACILITIES AND ASSOCIATED DEMARCATION POINTS

IV. SPECIAL CONDITIONS

A. Definitions

Complex Inside Wire. Telephone wire which connects station components to each other or to common equipment of PBX or Key System.

Individual Case Basis (ICB). The term "Individual Case Basis" denotes a condition where the regulations, if applicable, rates and charges for an offering under the provisions of this Product Guide are developed based on the circumstances in each case.

Industry Standard Wire/Cable. Wiring which conforms with industry standards and is installed in accordance with National Electrical Code and any other applicable standards or guidelines as identified in Special Condition III.B.2 following.

Intrabuilding Cable. Sheathed cable located on the customer side of the Local Loop Demarcation Point which may run vertically (riser cable) or horizontally (lateral cable) within a building or between buildings.

Lateral Cable. See Intrabuilding Cable

Local Loop Demarcation Point (LLDP). The LLDP is the point at which the Utility's facilities end and the property owner's facilities begin. For copper landline facilities only, the LLDP shall be located at the Minimum Point of Entry (MPOE).

Minimum Point of Entry (MPOE). The MPOE is the closest practicable point to where the Utility's facilities cross a property line or the closest practicable point to where the Utility's facilities enter a building(s).

Premises Wire. Customer provided wire between the INC demarcation point and the inside wire demarcation point. Where there is no INC cable, it is that wire between the Utility's local loop demarcation point and the inside wire demarcation point. Premises wire can be either inside wire or intrasystem wire depending on the terminating services and facilities.

Riser Cable. See Intrabuilding Cable

Cross-Connects. There are two types of cross-connects:

1. Utility Network Cross-Connects (UNICs)

Wires that connect the Utility's building entrance terminal to the Utility's network access termination point, e.g., ready access terminals (RATs) or Network Interface Units (NIUs). (These configurations comprise a small portion of the Utility's network.) Such cross-connects do not connect directly to the building owner's access terminal. They need not be altered in order for another Utility to provide service to customers. Therefore, they need not be accessible to other Utilities or the building owner. As a result, such cross-connects are part of the Utility's network. These cross-connects will be identified as UNICs.

Effective: April 1, 2016

---

INSIDE WIRE, INTRABUILDING CABLE, NETWORK FACILITIES AND ASSOCIATED DEMARCATION POINTS

IV. SPECIAL CONDITIONS (Continued)

A. Definitions (Continued)

Cross-Connects. There are two types of cross-connects: (Continued)

2. Service Provisioning Cross-Connects (SPCs)

Wires that connect the Utility's network access termination point to the building owner's access terminal. These are the cross-connects that may be removed or changed when a customer switches from one provider to another. Bridge clips that connect the Utility's network to the building owner's wiring are also SPCs.

Standard Network Interface (SNI). A type of Utility-owned network interface (isolation device) at which customer-owned facilities are connected to the telephone network.

Utility Provided Material Prices. Utility material charges include but are not limited to cost of material, taxes, freight charges and delivery to the customer premise.

B. General

1. The services offered in accordance with this Schedule are optional services. Arranging for installation, maintenance, and repair of cable, wire, jacks, and distribution terminals is the responsibility of the building owner. A building owner may choose a source for installation, maintenance, and repair other than the Utility.

Building owners who are not also subscribers will be subject to all legal remedies for non-payment including reasonable attorney fees and court costs.

2. The Utility will not be required to provision its services over INC cable that does not meet national, state, and local industry minimum safety, transmission, installation, and material quality standards. INC cable shall meet the technical specifications and standards such as those outlined by the following industry groups:
  - American National Standards Institute (ANSI)
  - National Electric Code (NEC)
  - Underwriter's Laboratories (UL)
  - Building Industry Consulting Service International (BICSI)
  - American Society for Testing and Materials (ASTM)
  - Institute of Electronics and Electrical Engineers (IEEE)
  - Electronic Industries Association (EIA)/  
Telecommunications Industries Association (TIA)
  - National Electrical Manufacturer's Association (NEMA)
  - Insulated Cable Engineering Association (ICEA)
  - National Electrical Safety Code (NESC)
  - National Recognized Testing Laboratories (NRTL)

Effective: April 1, 2016

---

INSIDE WIRE, INTRABUILDING CABLE, NETWORK FACILITIES AND ASSOCIATED DEMARCATION POINTS

IV. SPECIAL CONDITIONS (Continued)

B. General (Continued)

3. INC cable products shall be manufactured to, and used in accordance with, industry standards as identified in this section and shall be installed in accordance with local building codes and shall have the minimum industry rating for the application, e.g., CMR or higher for riser application.
4. If a customer requests, the Utility will, where possible, repair or replace substandard cable to meet the established industry standards. The charges for labor and material will be paid by the customer.
5. Demarcation locations will not be established on floating boat slips, piers, or docks.
6. The property owner shall be responsible for providing all appropriate facilities to allow installation of network facilities, including equipment rooms, wiring closets, wall space, mounting surface, lighting, and power outlets required for terminating network facilities. If a property owner does not provide sufficient termination facilities, network services will not be provided to tenants. If existing facilities lack sufficient power and/or space, new services will be provisioned as close as possible to the existing demarcation point.
7. Where a customer is so located that it is necessary to use private right-of-way to furnish service on continuous property, the customer will be required to pay the entire cost of serving and retaining such right-of-way. The customer will be required to pay all other costs associated with placing facilities to include but not limited to environmental requirements, easements, and changes required by building code.
8. Property owners are responsible for the security of and safety conditions surrounding Utility-owned facilities located on their property.
9. The property owner is responsible for placing all conduit for wire and cable.
10. For safety reasons, orders for service at hazardous locations will be treated on an individual basis and demarcation points negotiated accordingly. Hazardous locations include power substations and mines. (Certain fault conditions at a power substation can develop hazardous voltages at significant distances from the source and mines always have a potential for explosive or poisonous atmospheres.)
11. INC coverage does not include or imply that cable between buildings/units will be replaced under this maintenance agreement. The customer is responsible for:
  - a) Trenching under driveways, patios, etc.
  - b) Exposing buried/underground cable at defective location.
  - c) Replacement of defective cable.
  - d) Miscellaneous expenses associated with the above.
  - e) Major rearrangements resulting from damage to building/unit due to flood, fire, etc.
  - f) Replacement of exhausted cable.

Exhausted cable means working pairs plus manufacturer-defective pairs (non-repairable).

The maintenance agreement excludes damage caused by catastrophic loss (fire, flood, or other acts of nature) or the willful neglect of the building owner or agent. The Utility will perform restoration services for these damages under terms, conditions, and rates and Charges in III.A.3.a. Repair and Maintenance of INC.

Effective: April 1, 2016

---

INSIDE WIRE, INTRABUILDING CABLE, NETWORK FACILITIES AND ASSOCIATED DEMARCATION POINTS

IV. SPECIAL CONDITIONS (Continued)

B. General (Continued)

12. Frontier will not continue to maintain INC which the property owner has altered, added to, or otherwise tampered with.
13. Availability of Utility personnel for after hours and holiday work for Intrabuilding Cable Services is at the discretion of the Utility.

C. Intrabuilding Network Cable (INC)

1. General

Installation, design and maintenance of INC is available for all types of buildings. The customer under this portion of the Product Guide would be the building owner/landlord/agent who is not necessarily the subscriber to any particular Utility network service.

Arranging for installation, rearrangements, and repair of intrabuilding cable, inside wire, and jacks is not the responsibility of the Utility. A customer may choose a source for installation, rearrangements, and repair other than the Utility. Where there are not other vendors available, such as in rural areas, the Utility will be the provider of last resort.

The Utility is granted the right of access to the customer-owned/provided cable and the right to use pairs in such cable without charge to enable the Utility to provide and maintain the Utility's network services.

If the building owner does not allow the Utility the right to use sufficient pairs in customer-owned/provided cable without charge, or does not request that the Utility install the necessary cable to serve the Utility's subscribers, the Utility is not required to provide network services to reach such subscribers.

The Utility shall charge for installing and rearranging intrabuilding riser and lateral cable. The Utility will provide estimates of charges to applicants.

The Utility shall charge for repair of riser and lateral cable. The Utility is not responsible for the repair of any inside wire, riser and lateral cables which do not meet industry standards as specified in Special Condition IV.B.2.

Effective: April 1, 2016

---

INSIDE WIRE, INTRABUILDING CABLE, NETWORK FACILITIES AND ASSOCIATED DEMARCATION POINTS

IV. SPECIAL CONDITIONS (Continued)

C. Intra-building Network Cable (INC) (Continued)

2. In Place INC

In Place INC is cable installed prior to August 8, 1993.

As of August 8, 1993, the responsibility for maintenance of INC is transferred to the building owner together with its associated protective apparatus, terminal rooms, connecting blocks, and frames in "as is" condition without any representation as to quality or fitness. Further, the "as is" condition is without expressed or implied warranties as to merchantability; fitness for a particular purpose; permanence of right of way, easement, or locations; or any other matter whatsoever.

At the end of the five year amortization, from August 8, 1993, title and ownership of INC and associated protective apparatus and connecting blocks is transferred to the building owner.

Ownership of facilities not detailed in the preceding paragraph such as poles and conduit structure, shall remain with the Utility. Where no longer required by the Utility, these facilities may be priced for sale on an individual case basis.

The Utilities will have until August 31, 1998, to designate the primary INC Demarcation Points in at least a majority (51%) of the buildings and properties with respect to which construction or renovation has been completed prior to August 8, 1993. In the interim, the utilities will assist building owners, at no charge, to designate the primary Demarcation Point. The utilities will designate the primary Demarcation Point for new or renovated buildings or properties upon completion of construction.

All building owner requested rearrangements, changes, and removals required to separate the relinquished facilities from the Utility's network shall be performed by the Utility. Charges for installation and rearrangement of INC are applicable and shall be paid by the customer.

The Utility may further recover any extraordinary costs incurred during any special removal procedures requested by the customer. Costs shall be recovered based on current labor and material prices.

---

INSIDE WIRE, INTRABUILDING CABLE, NETWORK FACILITIES AND ASSOCIATED DEMARCATION POINTS

IV. SPECIAL CONDITIONS (Continued)

D. Demarcation Points

1. The Local Loop Demarcation Point (LLDP)

- a. The purpose of the Local Loop Demarcation Point is to separate the responsibility of the Utility from the responsibility of the building owner/customer by:
  - (1) designating the end of the network facility, thus the end of the local loop
  - (2) defining the beginning of the INC or inside wire provided by either the building owner or the Utility
- b. The Local Loop Demarcation Point may also be referred to as the Minimum Point of Entry (MPOE) or Minimum Point of Presence (MPOP) for the purpose of defining the end of the network facilities provided by the Utility.
- c. The Local Loop Demarcation Point will be located at the minimum point of entry, except as set forth in III.F.4. The Utility will not be required to place LLDPs on more than one floor in a multi-story building.
- d. The LLDP shall be accessible to the Utility at all times (twenty-four hours a day).
- e. Non-Utility installers are not permitted to install (IL-DP) demarcation devices absent an agreement with the Utility.

2. The Intrabuilding Demarcation Point (INCDP)

- a. The purpose of the Intrabuilding Demarcation Point is to separate the respective responsibilities of the building owner for providing INC from the end user's (subscriber's) responsibility for IW, jacks, and customer premises equipment by:
  - (1) designating the end of the INC
  - (2) defining the beginning of simple or complex IW
- b. The INCDP will be located at the distribution terminal on each floor except as set forth in IV.D.4.

3. The Inside Wire Demarcation Point (IWDP)

- a. The purpose of the Inside Wire Demarcation Point is to separate the responsibility of the IW vendor from the responsibility of the CPE vendor by:
  - (1) designating the end of the IW
  - (2) defining the beginning of the CPE facility



Effective: April 1, 2016

---

INSIDE WIRE, INTRABUILDING CABLE, NETWORK FACILITIES AND ASSOCIATED DEMARCATION POINTS

IV. SPECIAL CONDITIONS (Continued)

D. Demarcation Points (Continued)

4. Exceptions to Demarcation Points 1, 2 and 3

a. 911 Service

The Local Loop Demarcation Point will remain at the Utility provided CPE for all new and existing Utility provided E911/911 services. E911/911 services utilizing non-Utility provided CPE will be provisioned as shown in IV.D.1. preceding.

b. Non-Modular Disabled Services

Where non-modular CPE is provided by the Utility in accordance with FCC/CPUC rules, the Local Loop Demarcation Point is located at the CPE.

c. Mobile Home Parks

As defined in the General Exchange Tariff, Schedule D&R, shall not be considered Continuous Property. Instead, the Utility shall provide service to mobile home parks in a manner consistent with the provision of service to residential subdivisions containing detached, single-family homes.

d. Direct Feed Cable

Direct Feed Cable: If a property owner desires an additional Local Loop Demarcation Point at a specified location on a customer's premises for purposes of providing service assurance, safety, security and privacy of data communications over the cable (generally know as "direct feed"), the owner will be required to pay for the additional network cable and network facilities through special construction charges in accordance with the Utility's General Exchange Tariffs or this Product Guide. In particular, additional LLDP's cannot be used to extend any cable pairs served from any Local Loop Demarcation Point from one location to another location, i.e., from one building to another.

e. Fiber Optic Cable

The demarcation points noted shall apply to copper-landline facilities only.

f. Carrier Points of Presence (POP)

This Product Guide section shall not be construed to apply to access services provided to other common carriers, including access services provided to interexchange carriers, local exchange carriers and radio carriers (both private carriers and common carriers as defined by applicable Federal Communication Commission regulations). However, this Product Guide schedule does apply to exchange services provided to utilities, including interexchange carriers, acting in their capacity as end users of access services.

Effective: April 1, 2016

---

INSIDE WIRE, INTRABUILDING CABLE, NETWORK FACILITIES AND ASSOCIATED DEMARCATION POINTS

IV. SPECIAL CONDITIONS (Continued)

D. Demarcation Points (Continued)

4. Exceptions to Demarcation Points 1, 2 and 3 (Continued)

g. Specific Power and/or Space Requirements

Where existing facilities lack sufficient power and/or space to support provisioning of new service, the service will be provisioned as close as practicable to the existing demarcation point.

h. Exception to Continuous Property Provisions

Notwithstanding other provisions in Special Condition G, at the request of a property owner, the Utility may waive the designation of a single Local Loop Demarcation Point for a continuous property if, due to the unique characteristics of the property, a single Local Loop Demarcation Point would create a hardship for the property owner and/or the utility. Examples of such continuous property include (a) national, state and local parks, beaches, highways, harbors and similar publicly owned property and (b) railroad rights of way and extensive privately owned tracts of land with developed communities (e.g., Marina del Rey and similar privately owned property.) The Utility will treat land within the boundaries of privately owned property under (b) above that has the characteristics of continuous property e.g., (a) it is wholly leased by a single individual or entity and (b) it contains or will contain multiple buildings, as continuous property in accordance with all of the continuous property provisions as defined in the General Exchange Tariff, Schedule D&R.

This special condition is not intended in any way to waive the unbundling of INC and NTW in each building, as provided for elsewhere in this Product Guide schedule.

E. Location of Demarcation Points on Continuous Property

1. For new continuous property, regardless of type of use, the location of the Local Loop Demarcation Point will be at the appropriate main distribution terminal as determined by negotiations between the Utility and the property owner. Where no agreement can be reached, the Utility will designate the location of the Local Loop Demarcation Point. The customer must provide adequate termination facilities in accordance with the Product Guide. In the event the property owner does not provide such adequate termination facilities, the Utility will not provide network service to subscribers located on the property of the owner at that location.
2. For existing continuous property, the Utility will designate the main distribution terminal which is the Local Loop Demarcation Point, for each Local Loop serving the property, for purposes of unbundling of INC in each building. Where there is no main distribution terminal on existing Continuous Property, the current serving arrangements will not change unless and until such time as a rearrangement or reinforcement of serving arrangements and/or additional plant is required after August 8, 1993. At that time, the Utility will treat such property as new continuous property.
3. If a continuous property owner desires additional LLDP's or changes in existing LLDP, the owner will be required to pay for the additional network cable and network facilities required to install the additional LLDP through special construction agreements in accordance with the General Exchange Tariff, Schedule D&R, Rule 27. Additional LLDP cannot be used to extend any cable pairs serving from any LLDP from one location to another location. Only one LLDP per property will be provided by the Utility at no charge.

Effective: April 1, 2016

---

INSIDE WIRE, INTRABUILDING CABLE, NETWORK FACILITIES AND ASSOCIATED DEMARCATION POINTS

IV. SPECIAL CONDITIONS (Continued)

F. Relocation of the Minimum Point of Entry (MPOE) / Local Loop Demarcation Point (LLDP) on Continuous Multi-Tenant Property

1. The Utility shall relocate the MPOE/LLDP as requested by the property owner, or his or her agent only, provided that the following conditions are met:
  - a. The property owner agrees, and has the ability, to pay for all relocation expenses reasonably incurred.
  - b. Relocation is technically feasible. (The Utility bears the burden of proving technical infeasibility.)
  - c. Relocation is not prohibited by applicable local, state or federal laws, rules or regulations.
2. The charges for the relocation of the MPOE/LLDP will depend on each individual project. The cost of the project will include the engineering study costs, loaded labor costs, materials, necessary permits, and applicable taxes to complete the project.
3. The property owner, or his or her agent, will be required to pay the Utility's estimated total cost of the construction in advance. These charges are nonrefundable. Any difference between the amount advanced and the actual cost shall be remitted by the customer or refunded by the Utility, as the case may be, within 60 days after the customer is mailed notification of the actual cost or completion of the Utility's construction, respectively.
4. The estimated costs of the construction is valid for a period of 60 days from the date of presentation to the property owner, or his or her agent.
5. To the extent that the relocation of the MPOE/LLDP results in Utility property being transferred to the property owner, the Utility shall charge the property owner the net book value (recorded cost less accumulated depreciation) of the property.

G. Service Provisioning Cross Connects (SPCs)

1. SPCs shall be owned by the facilities-based carrier that provides service to the customer.
2. In the case of customers served by resellers, the underlying facilities-based carrier shall own the SPCs.
3. Utilities shall not remove or disconnect SPCs if it will result in a violation of Public Utilities Code Section 2883.
4. Whenever a Utility removes another carrier's SPCs, it shall do so in a safe manner that causes no harm to another carrier's facilities.
5. There are building configurations that have no building access terminals. In these cases, the inside wire runs from the customer's equipment directly to the Utility network access termination point. No SPC is utilized.

Effective: April 1, 2016

---

INSIDE WIRE, INTRABUILDING CABLE, NETWORK FACILITIES AND ASSOCIATED DEMARCATION POINTS

IV. SPECIAL CONDITIONS (Continued)

H. Serving Arrangements for Property Under Development

The utility will determine serving arrangements for properties under development according to the intended use of the property immediately following completion of construction. Under this condition, parcelized continuous property may be served as if the parcels were individually owned properties. Where the immediate intended use of parcelized continuous property is not clear, the utility may provision each parcel under special construction arrangements. If, within three years after the special construction billing date, the subdivided properties have been sold or held under separate ownership, the utility will reimburse any special construction charges previously paid in connection with such properties. If the subdivided properties have not been sold or held under separate ownership within such three-year period, the utility will not reimburse any special construction charges previously paid in connection with such properties.

I. Access to the Network

1. Responsibility for the protector (and its associated grounding) on the network side of the Local Loop Demarcation Point rests with the Utility. The customer or building owner is responsible for consequences resulting from erroneous wiring or cabling procedures conducted under his or her direction on the INC or IW.
2. Connection of wiring and terminal equipment to the telephone network may be made through a jack conforming to FCC Part 68, Subpart F. Connection of complex inside wiring to the Utility's network shall be in accordance with FCC Part 68, Subpart C of the FCC Rules and Regulations.
3. Access to INC will be accessible to the Utility at all times (twenty-four hours a day).
4. The Utility is granted the right of access to INC and the right to use pairs in such cable without charge to enable the Utility to provide and maintain those Utility Network Services.
5. When practical, the Utility will notify a building owner or landlord if access to INC is necessary.

J. Descriptions of Building Types, Continuous Property and Ownership

The date which determines whether a building is new, existing or fully renovated will be August 8, 1993. (The effective date of the implementation of the unbundling of the INC.)

"Fully Renovated Buildings" are those buildings in which internal wall coverings and existing telephone wiring and/or cable are removed in connection with renovations requiring a building permit. The effective date for determining "fully renovated" status is the date of the Notice of Occupancy issued by the appropriate local agencies.

1. Building Types

- a. Multi-story - A building with more than one floor or level
- b. Multi-unit - A building that has multiple tenants
- c. Single story - A building with one floor or level, excluding basements and garages or other parking facilities

Effective: April 1, 2016

---

INSIDE WIRE, INTRABUILDING CABLE, NETWORK FACILITIES AND ASSOCIATED DEMARCATION POINTS

IV. SPECIAL CONDITIONS (Continued)

J. Descriptions of Building Types, Continuous Property and Ownership (Continued)

2. Building Usage

a. Residential

(1) Single Family: Multi-story and Single story, but not Multi-unit:

A dwelling entirely occupied by one family or individuals functioning as one domestic household. Private garages, caretakers' quarters, and other locations such as private laundries, patios, garden houses, and private swimming pools that are part of the family's domestic establishment and used as part of the single family residence are considered part of the premises where located on the same continuous property.

(2) Multi-family: Multi-unit, Single story, or Multi-story or Both

A dwelling occupied by more than one family or more than one individual functioning as one domestic household. Examples include apartments, condominiums, town houses, and duplexes.

b. Commercial

(1) Single Tenant Commercial: Multi-story and single story, but not Multi-unit:

A building entirely occupied by one business customer.

(2) Multi-Tenant Commercial: Multi-unit, Multi-story, Single Story or Both:

A building occupied by more than one business customer.

c. Mixed Residential and Commercial: Multi-unit, Multi-story or Single Story:

A building occupied by both residential and business customers.

K. Isolation

Where an isolation device (SNI) is present, the Utility shall notify the customer/building owner that to isolate trouble on the customer side of the LLDP, a charge will be applicable. A premises visit charge will not apply if it is determined that the fault is within the Utility's network in accordance with Decision No. 04-05-058.

At the same time the Utility will advise the customer/building owner that they may choose alternatives to this, such as performing the isolation themselves or having another vendor perform the function.

Where no isolation device (SNI) has been installed, there will be no charge for a premises visit <sup>1</sup>, or for isolating the location (inside wire, network or customer premises equipment) of the trouble in accordance with Decision No. 04-05-058.

Effective: April 1, 2016

---

INSIDE WIRE, INTRABUILDING CABLE, NETWORK FACILITIES AND ASSOCIATED DEMARCATION POINTS

IV. SPECIAL CONDITIONS (Continued)

L. INC Service Offerings

1. The Utility may provide the following services for Intrabuilding Cable (INC).
  - a. Consultation and Design For Installation and Rearrangement of INC
  - b. Installation and Rearrangement of INC
  - c. Repair and Maintenance of INC
  - d. Additional Local Loop Demarcation Point (LLDP)
  - e. INC Cable and Diagram Service
  
2. Terms and Conditions
  - a. A firm order for service shall include all necessary information for the Utility to provide and bill for requested service(s). The Utility shall reflect the billing for this work on forms "Instructions for Billing-General and Instructions for Billing-Material". The Utility will provide an estimate of charges for the requested service(s). Once the charges have been accepted, the total charge to the customer will not exceed the estimate by more than 10% unless the additional charges are as a result of changes requested by the customer. After the charges are accepted by the customer, a cancellation fee that will include any cost or expense incurred by the Utility between the time of acceptance of charges and the completion of services ordered, will be the responsibility of the customer. In the event the actual charge is less than the estimate, the customer will be billed the actual amount.
  - b. The applicant is responsible to make suitable arrangements with all affected parties for the Utilities employees to enter and work on INC cable for all services ordered.
  - c. The Utility warrants that its service(s) will be performed in accordance with the standards established in this schedule. The Utility guarantees all parts and equipment against defects, including labor to replace the parts and equipment for a period of one year from the date of installation.
  - d. Other than the warranty set forth above, the Utility disclaims all other warranties, whether expressed or implied, not limited to but including warranties of merchantability and fitness for a particular purpose.
  - e. For the purposes of this Product Guide, INC is limited to copper facilities and associated materials and equipment. Customer requests for other types of facilities, such as fiber or coaxial cable are available on an individual case basis.
  - f. Installation of services are at the rates, terms and conditions found in other schedules of the Utility. Availability of Utility personnel for after hours and holiday work for Intrabuilding Cable Services is at the discretion of the Utility.

Effective: April 1, 2016

---

INSIDE WIRE, INTRABUILDING CABLE, NETWORK FACILITIES AND ASSOCIATED DEMARCATION POINTS

IV. SPECIAL CONDITIONS (Continued)

L. INC Service Offerings (Continued)

3. Consultation and Design Service

a. Consultation and design service may include:

Review and recommendation of designs for initial building telecommunications infrastructure and rearrangements for existing buildings.

Review of design and parameters of the services projected for use at the property.

Review and recommendation of building facilities needed including floor space, power, terminal sizing and access, conduit/supporting structure size and placement, and future growth requirements.

Review and recommendation of cable type, size, and service application.

Review and recommendation of alternative serving arrangements.

Documentation of designs, including architectural cabling plans, cable location drawings, and projected facility transmission parameters.

Development of Request for Proposal (RFP).

b. Charges for Consultation and Design Service will be applied toward the total cost of installation and rearrangement of INC if the customer places a firm order with the Utility for Installation or Rearrangement Service. Charges will be based on an hourly rate per technician, but will be billed on a cumulative hour(s) basis.

4. Installation and Rearrangements of INC

a. The Utility will install new INC cable within a customer's building(s). This cable may be installed in new buildings or to replace or supplement existing cable. The Utility will provide maps documenting the Utility installed cable type, terminal type and location, pair count availability and test parameters upon completion of the installation.

b. The Utility will rearrange INC cable and associated demarcation points within a customer's building(s). The Utility will remove accessible INC cable and its demarcation points as directed by the customer.

c. The Utility will offer a Consultation and Design service for rearrangements as described in IV.L.3.

d. The customer<sup>1</sup> will pay 50% of the estimated installation fee upon the work start date and the remainder after the work is completed. At the Utility's discretion, provisions found in the General Exchange Tariff, Schedule D&R, Rule No. 35, Extended Payment of One-Time Charges for Business Services, may apply. The payment of charges for the services offered under this Product Guide schedule transfers ownership of the installed facilities to the customer.

<sup>1</sup> Government entities as defined in G.0.96A, Section X, are excluded from the advance payment requirement of this paragraph.

Effective: April 1, 2016

---

INSIDE WIRE, INTRABUILDING CABLE, NETWORK FACILITIES AND ASSOCIATED DEMARCATION POINTS

IV. SPECIAL CONDITIONS (Continued)

L. INC Service Offerings (Continued)

4. Installation and Rearrangements of INC (Continued)

- e. The charges for Installation and Rearrangements of INC commence after a customer accepts the charges as specified in this Schedule. Charges will be based on an hourly rate per technician, but will be billed on a cumulative hour(s) basis.
- f. The Utility may install customer provided cable at the Utility's option, provided the cable meets industry standards as specified in Special Condition IV.B.2.

5. Repair and Maintenance

- a. At the request of the building owner, the Utility will provide repair and maintenance service for INC which include common maintenance and restoration for working pairs covered by agreement. Under this agreement, restoration will consist of the necessary repairs up to 10% (each incident) of the capacity of the cable. Necessary repair of cable pairs in excess of 10% will be provided under Repair and Maintenance of INC rates, in III.A.3.a. The maintenance agreement excludes damage caused by catastrophic loss (fire, flood, or other acts of nature) or the willful neglect of the building owner or agent. The Utility will perform restoration services to these damages under its Repair and Maintenance of INC rates in III.A.3.a.
- b. Per visit, repair and maintenance charges will be based on a per hour rate per technician, but will be billed on a cumulative hour(s) basis. The charges for Repair and Maintenance commence after a customer accepts the charges as specified in this schedule. Charges for materials used are in addition to the per hour charge.
- c. A Service Agreement Plan will be offered on a monthly basis at a monthly rate determined by contractual agreement until August 8, 1998. This service can be cancelled by the customer with a one-month (30-day) notice given to the Utility. The account balance will be calculated based on a prorated monthly amount and refunded to the customer. This service is only offered to building owners whose INC meets the accepted industry standards as described in this schedule. Substandard INC must be brought within industry standards by the building owner or by the building owner's request for the Utility to install INC in accordance with III.N.4 of this schedule. Unusual repair requirements and record corrections will be charged at the hourly and material repair and maintenance rates as shown in Section III.A.3.a. The Utility reserves the right to discontinue the service agreement plan upon 30 days written notice.

6. Additional LLDP Locations

The Utility will provide additional LLDPs at the building owner's request at the rates, terms and conditions found in Schedule No. D&R, Rule 27 for Special Construction. The Utility, where feasible, will install an aerial drop from an existing utility pole that supports existing Utility provided telecommunications services to serve a COPT line where the line is located within 25 feet of the pole. The charge for the drop will be included in the premise visit charge found in Product Guide Section 3.



Effective: April 1, 2016

---

INSIDE WIRE, INTRABUILDING CABLE, NETWORK FACILITIES AND ASSOCIATED DEMARCATION POINTS

IV. SPECIAL CONDITIONS (Continued)

L. INC Service Offerings (Continued)

7. INC Cable and Diagram Service

The Utility will provide copies of existing cable maps and diagrams to the customer based on the rates shown in III. Rates and Charges preceding. Charges to the customer for the establishment and design of new cable maps not in existence, are based on rates shown in III. Rates and Charges preceding.

8. INC Cable Maps

- a. Until August 8, 1998, Shareholders shall assume the costs for INC repairs of individual property owners who have requested INC cable maps, but do not receive it within 90 days of the request for owners of continuous property, and within 60 days for owners of all other types of property. Such information shall be limited to requests for cable maps for existing buildings with in-place INC cable installed by Frontier prior to August 8, 1993.
- b. The Utility's liability for repairs shall begin no sooner than 90 days from August 4, 1993 for continuous property or 60 days from August 4, 1993 for all other types of property, notwithstanding the date of the property owner's request. Property owners shall be responsible for demonstrating the date of receipt for their request by using certified mail or other verifiable methods of dating their requests.

Effective: April 1, 2016

---

FRONTIER CALLING PLANS

TABLE OF CONTENTS

	<u>SHEET NO.</u>
I. SPECIAL CONDITIONS	
A. General	1
B. Regulations	1
C. Plan Descriptions	2
1. Sensible Minute	2
2. 5 Cents Plan (Plan M) – Grandfathered as of November 16, 2013	3
3. Regional Toll Call Plan - Business	3
4. Corporate Rewards	4
5. Business Discount Rewards Program – Discontinued as of April 1, 2016	6
6. Discount Callings Plans	7
7. Calling Solutions	9
8. Flat Rate Business Calling Plus Savings Plan	10
II. RATES AND CHARGES	
A. Sensible Minute	12
B. 5 Cents Plan (Plan M) – Grandfathered as of November 16, 2013	12
C. Regional Toll Call Plan - Business	12
D. Corporate Rewards	13
E. Discount Callings Plans	15
F. Calling Solutions	18
G. Flat Rate Business Calling Plus Savings Plan	18

Effective: August 23, 2016

---

FRONTIER CALLING PLANS

I. SPECIAL CONDITIONS

A. GENERAL

1. There is no minimum IntraLATA Toll usage for Frontier Calling Plans.

Exception: A minimum usage charge will apply for Corporate Rewards when qualifying usage revenue aggregated from all qualifying BTNs does not meet the \$200.00 minimum usage threshold.

(T)

2. Frontier Calling Plans are available only where facilities and conditions permit.
3. Calling Solutions, Sensible Minute and 5 Cents Plan (Plan M) <sup>1</sup> are available to residential customers only.
4. Regional Toll Call Plan - Business, Flat Rate Business Calling Plus Savings Plan, Corporate Rewards, Business Discount Rewards Program <sup>2</sup>, and Frontier Client Advantage Program for Regulated Services (VCAP-R) Plan are available to business customers only.
5. No additional discounts apply for night or weekend calling for Calling Solutions-Option C, Sensible Minute, 5 Cents Plan (Plan M), Regional Toll Call Plan - Business, and Flat Rate Business Calling Plus Savings Plan for Business customers.

B. REGULATIONS

1. Sensible Minute, Calling Solutions-Option C and Corporate Rewards usage charges apply only to direct dialed IntraLATA Toll usage. Person-to-person, collect, calling card or any other calls requiring operator handling, are not included. The charges for these operator assisted calls are set forth in Section 20, Operator Services.
2. Regional Toll Call Plan - Business, Flat Rate Business Calling Plus Savings Plan, Calling Solutions – Options A and B and toll discounts apply only to the IntraLATA Toll usage portion of the call. Person-to-person, collect or any other calls requiring operator handling, are included. Operator Surcharges will be applied as set forth in Section 20, Operator Services.
3. A customer may only subscribe to one Frontier Calling Plans package per line.
4. One month minimum billing is required when subscribing to any Frontier Calling Plans package.  
  
Exception: Corporate Rewards does not require one month minimum billing.
5. When a Frontier Calling Plan is established at the same time as the associated primary service line, only the appropriate nonrecurring charges for establishing the primary service will apply. See Section 3, Service Charges.
6. Existing customers who subscribe to Frontier Calling Plans are not required to pay any Nonrecurring Charges from Section 3, Service Charges.

<sup>1</sup> Effective November 16, 2013, 5 Cents Plan (Plan M) is no longer available for purchase. Existing customers of record may retain this service at existing locations in accordance with the terms and conditions described herein. Service is not offered for new installations, moves, changes, or additions.

<sup>2</sup> Frontier is discontinuing the Business Discount Rewards Program. Plan points must be redeemed by July 31, 2016 or they will be forfeited.

Effective: April 1, 2016

---

FRONTIER CALLING PLANS

I. SPECIAL CONDITIONS (Continued)

B. REGULATIONS (Continued)

7. Established rates and charges for other services that the customer subscribes to in addition to the Frontier Calling Plans are applicable for those services.
8. The IntraLata Toll Service usage discounts are applicable to the IntraLATA Toll usage component of the Frontier Calling Plans packages only and do not apply to any other Company offered plan.
9. Corporate Rewards is not available in conjunction with the following types of service:
  - (a) Any local, toll or circuit switched data optional calling plan service
  - (b) Foreign Exchange Service
  - (c) Dormitory Service
  - (d) Enhanced 9-1-1 Service
  - (e) Directory Assistance
  - (f) National Directory Assistance
  - (g) California Relay Service and other Deaf and Disabled Telecommunication Programs
  - (h) Custom Calling Service
  - (i) Any service offered on an Individual Case Basis (ICB)

C. PLAN DESCRIPTIONS

1. Sensible Minute

This plan offers to residential customers a flat rate for all IntraLATA direct dialed calls. All IntraLATA Regional long distance calls will be billed at one rate per minute, 24 hours per day, 7 days per week. This plan is available to all existing and new customers. There are no nonrecurring charges with this calling plan.

Directory Assistance, operator handled, and calling card calls are excluded from this offer. Customers cannot enroll in any other calling plan in conjunction with this plan.

Effective: April 1, 2016

---

FRONTIER CALLING PLANS

I. SPECIAL CONDITIONS (Continued)

C. PLAN DESCRIPTIONS (Continued)

2. 5 Cents Plan (Plan M) <sup>2</sup>

The 5 Cents Plan (Plan M) is an optional plan for direct dialed IntraLATA toll calls. This plan offers flat rate pricing available 24 hours per day, seven days per week to residential customers in Frontier exchanges who subscribe to Frontier Local Package, Frontier Local Package Extra, Frontier Local Package Basic, or Frontier Local Package Prime.

Terms and Conditions

Calls are billed in one-minute increments.

There is no monthly rate or nonrecurring charge associated with this plan.

Directory Assistance, operator handled, and calling card calls are excluded from this service.

This service is available only on the line equipped with Frontier Local Package, Frontier Local Package Extra, Frontier Local Package Basic, or Frontier Local Package Prime. <sup>1</sup>

If the customer cancels subscription to Frontier Local Package, Frontier Local Package Extra, Frontier Local Package Basic, or Frontier Local Package Prime, another optional calling plan may be chosen. If no other optional calling plan is specified, the customer's account will default to the standard IntraLata Toll Service and rates as specified in Section 15, IntraLata Toll Service.

3. Regional Toll Call Plan - Business

Regional Toll Call Plan - Business offers business customers flat rate pricing, available 24 hours a day, 7 days a week for IntraLATA Regional long distance calls. This plan is available on a Month-to-Month option.

Calls will be billed in sub-minute rating, consisting of an initial period of 18 seconds and additional periods of 6 second increments. Each call will be billed an initial 18 second minimum. A fraction of a 6 second increment is rounded up to the next 6 second increment for all messages. There is no monthly recurring charge or nonrecurring charge with the Flat Rate Plan for Business.

The Flat Rate Plan for Business applies to the following calls: <sup>3</sup>

Customer Dialed Direct Station-to-Station  
Customer Dialed Calling Card Station-to-Station  
Operator Assisted Station-to-Station  
Operator Assisted Calling Card Station-to-Station  
Operator Assisted Person-to-Person

<sup>1</sup> See Section 6 of this Product Guide, Bundled/ Packaged Services

<sup>2</sup> Effective November 16, 2013, 5 Cents Plan (Plan M) is no longer available for purchase. Existing customers of record may retain this service at existing locations in accordance with the terms and conditions described herein. Service is not offered for new installations, moves, changes, or additions.

<sup>3</sup> Applicable surcharges still apply to calling cards and operator assisted calls.

---

FRONTIER CALLING PLANS

I. SPECIAL CONDITIONS (Continued)

C. PLAN DESCRIPTIONS (Continued)

4. Corporate Rewards

Corporate Rewards is a billing arrangement that provides business customers an optional calling plan with various discounts.

The various discounts offered by Corporate Rewards consist of the following components:

- a. Qualifying Usage - Uniform rates that do not vary by time of day or day of week, billed on a per minute basis and timed at one second increments, apply to the following types of customer-dialed station-to-station sent paid calls:
  - (1) Local Measured Service (LMS)
  - (2) Zone Usage Measurement (ZUM), including Circuit Switched Data
  - (3) Toll Usage Message Telecommunications Service (MTS), including Circuit Switched Data
- b. Volume Discount Rate - applies to qualifying, monthly usage services based on aggregated usage volumes across all customer Billing Telephone Numbers (BTNs) subscribing to Corporate Rewards. Qualifying usage revenue is based on rating usage at the Corporate Rewards base rate. The discount rate is automatically adjusted should a customer's qualifying revenue vary between Corporate Rewards Tiers. There is a maximum and a minimum qualifying usage threshold that a customer's usage must be within in order to qualify for a volume discount rate.
- c. Centrex Additive - The qualifying Corporate Rewards Tier for customers with Centrex lines is determined by adding together the qualifying usage revenue with the qualifying Centrex Additive revenue. Qualifying Centrex Additive revenue is determined by multiplying the qualifying Centrex lines by the Centrex line additive in II.E.5.
- d. Loyalty Discount - Customers who sign a 12-, 24-, or 36-month term agreement will qualify for a loyalty Discount. The Loyalty discount will apply in the thirteenth month when the Corporate Rewards service application is automatically renewed unless the customer terminates the application in writing. For each consecutive renewal, up to and including the fifth year, a customer will receive an increased loyalty discount. After the fifth year, customers will continue to receive a loyalty discount capped at the fifth year discount level. The loyalty discount will apply to the customer's discounted monthly usage rates and will be applied on a BTN level. Customers that exceed Tier 4 maximum monthly aggregated usage volume will not receive a loyalty discount.
- e. Corporate Rewards is not available in the areas served by the following wire centers: Earp Big River, Havasu Landing, Blythe and Palo Verde.

Effective: April 1, 2016

---

FRONTIER CALLING PLANS

I. SPECIAL CONDITIONS (Continued)

C. PLAN DESCRIPTIONS (Continued)

4. Corporate Rewards (Continued)

- f. Monthly Access Discount - applies to Centrex, Business lines and PBX trunk, PRI Access Interface, and PRI Access Switched Facility System. Customers will receive a fixed dollar discount monthly on eligible access lines. Access lines included in customer specific pricing agreements are ineligible for the access line discount. However, customers with customer specific pricing agreements are eligible to subscribe and receive the benefits of all the other Corporate Rewards components. Customers that exceed Tier 4 maximum monthly aggregated usage volume will not receive access line discounts. Customers that do not exceed Tier 1 maximum monthly usage volume will also not receive access line discounts. Access Line/Service Discounts will apply only for customers qualifying for Tier 2, Tier 3, or Tier 4 who purchase qualifying services from the Company's Product Guide at month-to-month rates (or other shortest term where month-to-month is not available). Exception to this condition applies as follows: PRIs under a term agreement are eligible for the one-year Corporate Rewards discounts. Corporate Rewards Centrex discounts will apply to lines under a Centrex without Toll three-year or less term.
- g. Minimum Usage Threshold - A customer must meet a minimum monthly usage threshold. The minimum monthly usage threshold is \$200.00. Should a customer's actual monthly aggregate qualified usage revenue from all BTN's on the Plan be less than the minimum usage rate threshold, a minimum usage charge will be applied to the customer's main billing telephone number. The minimum usage charge is equal to the difference between the minimum monthly usage threshold and the customer's actual monthly aggregate qualified usage revenue.
- h. Service Application - Customers are required to sign a 12-, 24-, or 36-month service application, and return the service application prior to the service being established. At the end of the term period, the service application will be automatically renewed for an additional term equivalent to the Customer's original term length unless the customer notifies the Utility otherwise. The auto renewal will allow for a 60 day grace period for the subscriber to remove the plan without penalty. Customers will be required to identify a Main BTN in the service application to which any minimum usage charge or termination charge will be applied.
- i. Termination - Customers may terminate participation at any time provided the customer gives a 60-day written notice. Termination will occur on the first day of the full billing period following the 60-day notification period.<sup>1</sup> If a customer chooses to cancel the service or disconnects their main billing telephone number prior to the anniversary date of the term, a termination charge will apply.

In addition, customers who sign a 24- or 36-month service agreement will be required to return all access line discounts received in accordance with their service agreement. Discounts that must be returned will be calculated as follows:

Number of access lines/services X discount amount per access line/service X number of months expired under the service agreement

A customer is exempt from paying a termination charge under the following conditions:

- (1) A customer migrates to another Frontier plan or service of equal or greater value.
- (2) The Company receives written notice prior to the anniversary date of the term that the customer wishes to terminate the plan. The plan will be terminated in the first full billing period following the 60-day written notice or the first full billing period following the anniversary date, whichever is later.

<sup>1</sup> There will be no partial monthly billing by the Company.

Effective: January 19, 2021

---

FRONTIER CALLING PLANS

I. SPECIAL CONDITIONS (Continued)

C. PLAN DESCRIPTIONS (Continued)

5. Business Discount Rewards Program <sup>1</sup>

Beginning August 1, 2012, eligible small business customers may earn points for qualifying purchases of tariffed services that can be redeemed under special Business Discount Rewards Program programs sponsored by Frontier Business Discount Rewards Program programs are programs in which participants may receive points based on qualifying purchases, activities or other factors and redeem points earned for credits or rewards available under the terms of the program.

Regulations

Business Discount Rewards Program is available only to customers who enroll in the Plan. The Plan is available beginning August 1, 2012.

Eligible customers are entities other than residential or government customers 1) whose basic exchange service is provided by Frontier and 2) who have fewer than 20 lines.

The Plan is not available to residence customers, nor does it apply to Customer Owned Pay Telephone (COPT) lines, or certain services provided under contract (including all Individual Case Basis [ICB] arrangements).

Customers may not be enrolled in both Corporate Rewards and Business Discount Rewards Program.

Plan points are awarded for Frontier monthly recurring and nonrecurring charges for local and regional services, and certain enhanced services determined by Frontier. Those enhanced services include Long Distance, High Speed Internet (DSL) and Frontier® FiberOptic Internet. Plan points are awarded monthly after the application of other allowances and discounts and are limited to 500 points per month. Charges for Directory Advertising, enhanced services, late payment, time and material charges, returned check charges, Frontier maintenance service, refund checks, all taxes and surcharges, disputed amounts and any non-Frontier billed local or toll usage are excluded. (C)

The qualifying charges include monthly recurring and nonrecurring charges for Frontier local and regional services, Frontier Communications of America, Inc. (billed by Frontier Enterprise Solutions), Frontier business high speed internet and Frontier® FiberOptic Internet business internet services. (C)

Plan points are calculated monthly as specified in II.F. following, and posted to the enrolled customer's Business Discount Rewards Program Account Summary within ninety (90) days of the date the Plan points were earned. These points can be redeemed for various Company-sponsored redemption options when they are posted to the customer's account.

The Business Discount Rewards Program previously provided for in this section is discontinued. Customers who accrued points under the previous Business Discount Rewards Program that is discontinued on July 31, 2012 will have the choice to either 1) redeem point balances under the program until December 31, 2012 or 2) to have their points transferred to the new Rewards program by registering in the new Rewards program by December 31, 2012. Points that are transferred must be redeemed by July 31, 2013.

<sup>1</sup> Frontier is discontinuing the Business Discount Rewards Program. Plan points must be redeemed by July 31, 2016 or they will be forfeited.



Effective: April 1, 2016

---

FRONTIER CALLING PLANS

I. SPECIAL CONDITIONS (Continued)

C. PLAN DESCRIPTIONS (Continued)

5. Business Discount Rewards Program <sup>3</sup> (Continued)

Terms and Conditions (Continued)

Eligible customers do not need to meet any minimum monthly billing amount to participate in a Rewards program and earn points for qualifying purchases, but customers must register to participate and comply with program rules. Points earned on qualifying purchases will be limited to \$500 per month.

Plan points that are not redeemed within 12 months after the month in which they are posted will be forfeited.

Plan points are not transferable between accounts of the same customer or different customers. Points may not be sold, bartered or assigned to another customer's account. Only eligible business Customers of Record and/or their designated agent(s) may redeem Plan points.

Opportunities for new or existing enrolled customers to receive additional Plan points may occur periodically.

Continued participation in the Plan requires that the customer continues to meet the requirements specified in this guide. If, at any time, the customer fails to meet any of the Plan eligibility requirements, the Company, at its discretion, can terminate Plan participation after customer notification has occurred. Plan points awarded to the customer prior to termination may be used as set forth in the preceding paragraphs.

The Company may modify or terminate all or any part of this Plan, or any of the point redemption offers, at any time. Notice of such changes will be provided to existing customers by the Company at least 30 days prior to their effective dates. In the event of termination of the Plan, customer notification will be provided at least 90 days in advance of the Plan termination date, and will include the date by which all Plan points must be redeemed.

6. Discount Callings Plans

Description

Discount Calling Plans are optional toll calling plans that customers may subscribe to comprised of a monthly recurring charge and discounted usage as follows:

Discount Calling Plan One <sup>1</sup> - Business- \$5.00 monthly with a 15% discount off of day, evening and night calling.

Term Arrangements is available for Discount Calling Plan One.

Regional Toll Call Plan - Business <sup>2</sup>

Regional Toll Call Plan - Business is an optional 1+, 0+, and 0- Intrastate IntraLata Toll Service offered only to business customers.

<sup>1</sup> This service is grandfathered and limited to existing end user customers subscribing to this plan at the same customer premises only as of November 26, 1996.

<sup>2</sup> Regional Toll Call Plan - Business and Regional Toll Call Plan are grandfathered and limited to existing customers at existing locations as of January 13, 2005.

<sup>3</sup> Frontier is discontinuing the Business Discount Rewards Program. Plan points must be redeemed by July 31, 2016 or they will be forfeited.

Effective: April 1, 2016

---

FRONTIER CALLING PLANS

I. SPECIAL CONDITIONS (Continued)

C. PLAN DESCRIPTIONS (Continued)

6. Discount Callings Plans (Continued)

General

- (a) Residence and Business customers may, for the indicated nonrecurring and monthly rates as shown in this Section, receive a discount on select intraLATA message toll charges.
- (b) The service provides an alternate rate treatment for Message Toll Telephone Service calls to exchanges within the customer's designated LATA.
- (c) The service is offered with discounted call detail.
- (d) IntraLata Toll Service is authorized by Decision 94-09-065 as a flexibly priced service. The rates and applicable service charges may be increased (not to exceed the ceiling on file with the Commission) by the Utility upon at least 30 days notice to the CPUC and affected customers. As authorized by Decision 96-03-020, rates may be decreased (not below the rate floor on file with the Commission) by the Utility upon 5 days notice to the CPUC.
- (e) Adjustments in rates, including tiers and thresholds, as a result of flexible pricing described in 4 preceding become effective the first bill date after the effective date of the rate change.
- (f) In Discount Calling Plan Six, each individually directly dialed call is completed on the basis of six second increments with a minimum billing of 18 seconds per message. For all messages, a fraction of a six second increment is rounded up to the next six second increment.

Terms and Conditions

- (a) Person, collect or any other calls requiring operator handling, are included. Discount Calling Plan rates will apply to the message toll portion of the call only. Operator Surcharges will be applied as set forth in this Product Guide.
- (b) These discounts are applicable to the Discount Calling Plans only and do not apply to any other Utility offered plan.
- (c) A customer may only subscribe to one Discount Calling Plan per main billing number.
- (d) Local, EAS and ZUM Zone 3 (as set forth in the General Exchange Tariff, Schedule No. A-1 and Section 5 of this Product Guide) calls do not apply to the Discount Calling Plans.
- (e) One month minimum billing is required when subscribing to any Discount Calling Plan.
- (f) Discount Calling Plans are not available on WATS and 800 Services.
- (g) Discount Calling Plan usage may be aggregated for COPT Providers with a single billed telephone number.

---

FRONTIER CALLING PLANS

I. SPECIAL CONDITIONS (Continued)

C. PLAN DESCRIPTIONS (Continued)

7. Regional Toll Call Plan - Business <sup>1</sup>

(1) Application of Discounts

The discounts are provided to the Utility's business customer only and shall not be used for any purpose for which a payment or other compensation shall be received by the customer from any other person, firm or corporation for such use. Therefore, these plans are not available for resale out of this Product Guide.

Regional Toll Call Plan - Business discount percentages apply to the IntraLata Toll Service portion of the call, the Operator Handled Service Charges, if applicable.

These discounts are applicable to the Regional Toll Call Plan - Business only and do not apply to any other Utility offered plan.

(2) Term Periods for Regional Toll Call Plan - Business

A customer may select a term period for Regional Toll Call Plan - Business. The term periods allow customers to take advantage of higher discount percentages on their toll usage volumes for a one or three year term period.

The customer must specify the term period at the time Regional Toll Call Plan - Business is ordered.

During a term period, the customer may elect to convert to a new term period of the same or different length. Conversion to a new term period will be allowed without penalty if the expiration date of the new term period is greater than the remainder of the original term period.

(3) Early Termination Charges

In the event the Regional Toll Call Plan - Business is terminated by the business customer prior to completion of the term period, the customer shall be liable for the Early Termination Charge. The customer shall be required to make the immediate payment of the following applicable amount:

Early Termination Charge:

One Year Term	\$100.00
Three Year Term	300.00

<sup>1</sup> Regional Toll Call Plan - Business is grandfathered and limited to existing customers at existing locations as of January 13, 2005.

Effective: April 1, 2016

---

FRONTIER CALLING PLANS

I. SPECIAL CONDITIONS (Continued)

C. PLAN DESCRIPTIONS (Continued)

7. Regional Toll Call Plan - Business <sup>1</sup>

(4) Regional Toll Call Plan - Business provides a discount on IntraLata Toll Service Intrastate IntraLATA calls. The discount applies when the customer meets and/or exceeds the required IntraLATA Toll usage dollar amount. There is no monthly rate associated with Regional Toll Call Plan - Business. The Plan includes:

- Business (Direct Dialed)
- Operator Handled

(5) Regional Toll Call Plan - Business does not apply to Local (including Measured-Rate Usage), ZUM, and EAS calls as found in Sections 4 and 5 of this Product Guide.

(6) The minimum service period for Regional Toll Call Plan - Business is one month.

8. Calling Solutions <sup>2</sup>

Calling Solutions are packages of services that allow customers to combine vertical services with IntraLata Toll Service for a discounted monthly rate. There are three options that are available.

(a) Option A

- 15% Discount on IntraLATA Toll
- Inside Wire Maintenance Plan (IWMP)
- Frontier Voice Mail with Individual Message Box
- Call Waiting
- Cancel Call Waiting
- Call Forwarding
- 8 Number Speed Calling
- 3-Way Calling

<sup>1</sup> Regional Toll Call Plan - Business is grandfathered and limited to existing customers at existing locations as of January 13, 2005.

<sup>2</sup> This service is grandfathered and limited to existing end user customers subscribing to this plan at the same customer premises only as of Nov. 26, 1996.

Effective: April 1, 2016

---

FRONTIER CALLING PLANS

I. SPECIAL CONDITIONS (Continued)

C. PLAN DESCRIPTIONS (Continued)

9. Flat Rate Business Calling Plus Savings Plan

Flat Rate Business Calling Plus Savings Plan- Business offers to business customers a flat rate pricing, available 24 hours a day, 7 days a week for IntraLATA Regional long distance calls. The billing options available are a 1 year or 3 year contract. Calls will be billed in sub-minute rating, consisting of an initial period of 18 seconds rated at 3/10 of the per minute rate and additional periods of 6 second increments, rated at 1/10 of the per minute rate. Each call will be billed an initial 18 second minimum. There are no monthly or nonrecurring charges with this billing option.

The Flat Rate Business Calling Plus Savings Plan applies to the following types of calls:

Customer Dialed Direct Station-to-Station

Operator Assisted Station-to-Station

Operator Assisted Person-to-Person

The customer must specify the term period at the time the Plan is ordered. During a term period, the customer may elect to convert to a new term period of the same or different length, or to another Frontier term plan. Conversion to a new term plan or another Frontier term plan will be allowed without penalty if the new term period is greater than the remainder of the original term period.

Early Termination Charges will apply in the event the Flat Rate Plus Plan is terminated by the customer prior to completion of the term period. The customer will be liable for the remainder of the months selected in the Plan.

Early Termination Charge = \$25.00 x the number of months remaining in the term period selected

Effective: April 1, 2016

---

FRONTIER CALLING PLANS

II. RATES AND CHARGES

A. SENSIBLE MINUTE

The following per minute of use rate applies 24 hours per day, 7 days per week.

<u>Rate Per Minute</u>	<u>Monthly Charge</u>
\$ .08	\$5.00

B. 5 Cents Plan (Plan M) <sup>2</sup>

The following per minute of use rate applies 24 hours per day, 7 days per week.

	<u>Rate Per Minute</u>
5 Cents Plan (Plan M) <sup>1</sup>	\$0.05

C. REGIONAL TOLL CALL PLAN - BUSINESS

Sub-minute of Use Charges

	<u>Rate Per Sub-Minute</u>
Month-to-Month	
Initial 18 Seconds	\$ .0270
Each Additional Six Seconds	.0090

<sup>1</sup> Directory assistance, operator handled, and calling card calls are excluded from this service.

<sup>2</sup> Effective November 16, 2013, 5 Cents Plan (Plan M) is no longer available for purchase. Existing customers of record may retain this service at existing locations in accordance with the terms and conditions described herein. Service is not offered for new installations, moves, changes, or additions.

Effective: April 1, 2016

FRONTIER CALLING PLANS

II. RATES AND CHARGES (Continued)

D. CORPORATE REWARDS

The following rates are applicable to Local Measured Service (LMS), Zone Usage Measurement (ZUM) service and Toll Usage Message Telecommunications Service (MTS) and include Circuit Switched Data. Customer must pay a minimum of \$200.00 each month for Qualifying Usage aggregated from all of the customer's Qualifying BTNs.

	<u>LMS</u>	<u>ZUM</u>	<u>Toll</u>	
1. Base Rate, per minute	\$0.040	\$0.050	\$0.1000	
2. Volume Discount Rate, per minute				
Tier 1 - Total qualifying monthly usage from \$ .01 to \$ 999	0.040	0.050	0.1000	
Tier 2 - Total qualifying monthly usage from \$ 1,000 to \$ 9,999	0.016	0.030	0.0430	
Tier 3 - Total qualifying monthly usage from \$ 10,000 to \$ 49,999	0.014	0.028	0.0420	
Tier 4 - Total qualifying monthly usage from \$ 50,000 to 299,999	0.013	0.026	0.0415	
Tier 5 - Total qualifying monthly usage from \$ 300,000 +	0.040	0.050	0.1000	
3. Loyalty Discount, per minute	<u>2nd Yr</u>	<u>3rd Yr</u>	<u>4th Yr</u>	<u>5th Yr</u>
Tier 1	2%	3%	4%	5%
Tier 2	2%	3%	4%	5%
Tier 3	2%	3%	4%	5%
Tier 4	2%	3%	4%	5%
Tier 5 Plus	0%	0%	0%	0%
4. Monthly Access Discount, <sup>1</sup> per line/trunk/service		<u>Monthly Discount</u>		
	<u>12-Month</u>	<u>24-Month</u>	<u>36-Month</u>	
Tier 2				
PRI Access Interface, per service	\$48.00	\$242.00	\$267.00	
PRI Access Switched facility system, per service	48.00	175.00	200.00	
Business Line, per line	1.00	1.00	3.50	
PBX Trunks, per line	1.00	1.00	3.50	
Centrex, per line	2.00	2.00	2.00	
Tier 3				
PRI Access Interface, per service	48.00	267.00	297.00	
PRI Access Switched facility system, per service	48.00	200.00	225.00	
Business Line, per line	1.00	1.50	4.00	
PBX Trunks, per line	1.00	1.50	4.00	
Centrex, per line	2.00	2.00	2.00	
Tier 4				
PRI Access Interface, per service	48.00	297.00	347.00	
PRI Access Switched facility system, per service	48.00	225.00	275.00	
Business Line, per line	1.00	2.00	4.50	
PBX Trunks, per line	1.00	2.00	4.50	
Centrex, per line	2.00	2.00	2.00	

<sup>1</sup> Customers who qualify for Tier 1 or Tier 5 are not eligible for the Monthly Access Discount.

Effective: April 1, 2016

---

FRONTIER CALLING PLANS

II. RATES AND CHARGES (Continued)

D. CORPORATE REWARDS (Continued)

- |  |          |
|--|----------|
| 5. Centrex Additive - monthly per line value | \$ 25.00 |
| 6. Termination Charge                        | 500.00   |

In addition, customers who have signed a 24- or 36-month service agreement will be required to return all access line discounts received in accordance with their service agreement. Discounts that must be returned will be calculated as follows:

Number of access lines/services X discount amount per access line/service X number of months expired under the service agreement.

- |                          |        |
|--------------------------|--------|
| 7. Minimum Use Threshold | 200.00 |
|--------------------------|--------|



Effective: April 1, 2016

FRONTIER CALLING PLANS

II. RATES AND CHARGES (Continued)

E. DISCOUNT CALLING PLANS

DISCOUNT CALLING PLAN ONE

1. BUSINESS <sup>3</sup>

- (a) Monthly Recurring Charge = \$5.00 per main billing number
- (b) Service Order Charges will be applied as set forth in Section 3.
- (c) Usage Charges:

Usage charges for Discount Calling Plan One are designed to provide a discount for Day, Evening, and Night toll usage.

Rates: Day, Evening, Night<sup>1</sup>

	<u>Rate Mileage<sup>2</sup></u>	<u>Initial 1-Minute</u>	<u>Each Additional Minute</u>
<u>Day Rate</u>	0-12	0.0969	0.0595
	13-16	0.0969	0.0595
	17-20	0.0969	0.0595
	21-25	0.1156	0.0969
	26-30	0.1156	0.0969
	31-40	0.1156	0.0969
	41-50	0.1156	0.0969
	51-70	0.1156	0.0969
	71+	0.1156	0.0969
<u>Evening Rate</u>	0-12	0.0775	0.0476
	13-16	0.0775	0.0476
	17-20	0.0775	0.0476
	21-25	0.0925	0.0775
	26-30	0.0925	0.0775
	31-40	0.0925	0.0775
	41-50	0.0925	0.0775
	51-70	0.0925	0.0775
	71+	0.0925	0.0775
<u>Night Rate</u>	0-12	0.0581	0.0357
	13-16	0.0581	0.0357
	17-20	0.0581	0.0357
	21-25	0.0689	0.0581
	26-30	0.0689	0.0581
	31-40	0.0689	0.0581
	41-50	0.0689	0.0581
	51-70	0.0689	0.0581
	71+	0.0689	0.0581

<sup>1</sup> These rates reflect a 15% discount off of IntraLata Toll Service.

<sup>2</sup> Local, EAS and ZUM Zone 3 calls not included.

<sup>3</sup> This service is grandfathered and limited to existing end user customers subscribing to this plan at the same customer premises only as of Nov. 26, 1996.

Effective: April 1, 2016

---

FRONTIER CALLING PLANS

II. RATES AND CHARGES (Continued)

E. DISCOUNT CALLING PLANS (Continued)

REGIONAL TOLL CALL PLAN - BUSINESS <sup>1</sup>

Regional Toll Call Plan - Business is an optional 1+, 0+, and 0- Intrastate IntraLata Toll Service offered only to business customers. The discounts offered with Regional Toll Call Plan – Business are not available with any other Utility offered discount calling plan.

Business customers who subscribe to Regional Toll Call Plan - Business will receive the following discounts on all IntraLATA Toll usage billed for the month when their monthly usage exceeds:

Monthly Frontier IntraLATA Toll Usage	Month-to-Month <u>Discount</u>	1 Year <u>Discount</u>	3 Year <u>Discount</u>
\$ 0 - 4.99	0%	5%	10%
\$ 5.00 - 49.99	10%	12%	15%
\$ 50.00 - 99.99	10%	15%	20%
\$100.00 and over	15%	20%	25%

RESIDENCE DIRECT DISCOUNT PLAN

Directly dialed calls shall receive a 15% discount on the total amount billed over \$5.00.

<sup>1</sup> Charges from Section 3 of this Product Guide are not applicable.

Effective: April 1, 2016

FRONTIER CALLING PLANS

II. RATES AND CHARGES (Continued)

E. DISCOUNT CALLING PLANS (Continued)

BUSINESS DIRECT DISCOUNT PLAN <sup>1</sup>

Directly dialed toll calls shall receive a 20% discount on the total qualified amount billed over \$15.00.

BUSINESS ADVANTAGE 50 <sup>1,2</sup>

	<u>Installation Charge</u>	<u>Monthly Rate</u>
Advantage 50	\$10.00	\$7.50

Option 1

<u>Billed Usage</u>	<u>Discount Rate</u>
\$0.01 - \$300.00	30%
\$300.01+	35%

Option 2

<u>Hourly Rate</u>	<u>Billed Hourly Usage</u>	<u>Discount Rate</u>
\$5.75 per hour of usage	\$0.01 - \$300.00 \$300.01+	30% 35%

BUSINESS ADVANTAGE 1000 <sup>1</sup>

	<u>Installation Charge</u>	<u>Monthly Rate</u>
Advantage 1000	\$10.00	\$30.00

Option 1

<u>Billed Usage</u>	<u>Discount Rate</u>
\$0.01 - \$1,000.00	30%
\$1,000.01 - \$5,000.00	40%
\$5,000.01 +	50%

Option 2

<u>Hourly Rate</u>	<u>Billed Hourly Usage</u>	<u>Discount Rate</u>
\$5.75 per hour of usage	\$0.01 - \$1,000.00 \$1,000.01 - \$5,000.00 \$5,000.01 +	30% 40% 50%

<sup>1</sup> The above discount plan is grandfathered and limited to existing customers in the exchanges listed in Section 5 of this Product Guide, Sheet 3.

<sup>2</sup> Business Advantage 50 Discount Calling Plan is withdrawn as of July 21, 2014. Effective October 18, 2014, this service is also withdrawn at the resale level and no longer available for purchase by resale customers.

Effective: April 1, 2016

FRONTIER CALLING PLANS

II. RATES AND CHARGES (Continued)

F. CALLING SOLUTIONS <sup>2</sup>

	<u>Nonrecurring Charge</u>	<u>Monthly Rate</u>	<u>Frontier IntraLATA Toll</u> <sup>1</sup>
1. Option A	\$7.50	\$17.45 (I)	15%
2. Option B	7.50	23.45	25%
3. Option C	7.50		
Initial Hour - per month		4.98	
Additional Minutes per minute			\$ 0.10

G. FLAT RATE BUSINESS CALLING PLUS SAVINGS PLAN

1. Sub-minute of Use Charge

	<u>Rates Per Sub-Minute</u>	
	<u>Initial 18 Seconds</u>	<u>Each Additional 6 Seconds</u>
1 Year Term	\$.030	\$.010
3 Year Term	.030	.010

2. Early Termination Charge

\$25.00 times the number of months remaining in the term period selected

<sup>1</sup> This percentage represents a discount off of IntraLATA Toll Usage rates. For IntraLATA Toll Usage rates see Section 16 of this Product Guide.

<sup>2</sup> This service is grandfathered and limited to existing end user customers subscribing to this plan at the same customer premises only as of Nov. 26, 1996.

Effective: November 13, 2019

---

OPERATOR SERVICES

TABLE OF CONTENTS

	<u>SHEET NO.</u>	
I. DESCRIPTION		
A. Operator Handled Service	1	
B. Pay Station Service Charge	2	
C. Number Referral Services	2	
D. Live Operator Fee	2	(N)
II. SPECIAL CONDITIONS		
A. Method of Applying Rates	4	
B. Number Referral Services	5	
III. RATES AND CHARGES		
A. Operator Handled Service Charges		
1. Operator Handled Credit/Calling Card Calls	5	
2. Operator Handled Station-to-Station	5	
3. Operator Handled Person-to-Person	5	
B. Pay Station Service Charge	5	
C. Number Referral Services	6	
D. Live Operator Fee	6	(N)

---

OPERATOR SERVICES

I. DESCRIPTION

A. OPERATOR HANDLED SERVICE

Operator Handled Service includes:

Operator Handled Station-to-Station Service (Direct Dialed)  
Operator Handled Station-to-Station Service (Coin)  
Operator Handled Station-to-Station Service (Corrections Collect)  
Operator Handled Person-to-Person Service (Direct Dialed)  
Operator Handled Person-to-Person Service (Coin)  
Customer Owned Pay Telephone (COPT) Service

1. Operator Handled Station-to-Station Service (Direct Dialed)

Operator Handled rates plus the Operator Handled Station-to-Station service charge apply to:

- Station messages billed to the called number, a third telephone number or a calling card where the calling card surcharge shown in III.A.1. does not apply.
- Station messages where the customer requests time and charges quoted.
- Interexchange Receiving Service messages (Enterprise or Zenith).
- Messages to or from a Mobile telephone where dial facilities are not available.

2. Operator Handled Station-to-Station Service (Coin)

Coin Station rates plus the Operator Handled Station-to-Station (Coin) service charge apply to station-to-station messages originating at a public telephone that are paid for by coin deposit.

3. Operator Handled <sup>1</sup> Station-to-Station Service (Corrections Collect Service)

Corrections Collect rates and the Operator Handled Station-to-Station Correction Collect service charges apply to station-to-station messages that originate from a correctional facility and utilize special equipment to restrict calls to victims, witnesses, officers of the court, correctional officers, and others.

4. Operator Handled Person-to-Person Service (Direct Dialed)

Operator Handled rates plus the Operator Handled Person-to-Person service charge apply to:

- Messages for which the person originating the call specifies a particular person to be reached at the called point or a particular station, department, office or branch reached through an attendant at the called point.

When, after the telephone service called has been reached, and while the connection remains established, the person originating the call requests or agrees to talk to any person other than the person specified, or to any other station, department, office or branch to be reached through an attendant, the call remains classified as a person-to-person service call.

<sup>1</sup> Operator is mechanized; live operator is not provided.

Effective: November 13, 2019

---

OPERATOR SERVICES

I. DESCRIPTION (Continued)

A. OPERATOR HANDLED SERVICE (Continued)

5. Operator Handled Person-to-Person Service (Coin)

Coin station rates plus the Operator Handled Person-to-Person (Coin) service charge apply to person-to-person messages originating at a public telephone that are paid for by coin deposit.

6. Customer-Owned Pay Telephone (COPT) Service

- The Operator Handled Person-to-Person service charge (Direct Dialed) applies to person-to-person messages originating at a COPT on a non sent-paid call.

B. PAY STATION SERVICE CHARGE

In addition to the IntraLATA Toll rates (Section 28 of this Product Guide) and any applicable Operator Handled service charge in Rates and Charges III.A., the Pay Station Service Charge III.B. following, applies to each local and intraLATA toll non sent-paid message made over a pay telephone owned by a Company or any other pay telephone provider choosing to impose the charge.

C. NUMBER REFERRAL SERVICES

1. Basic Referral

Basic Referral Service is offered to customers (where facilities permit) who have either moved to a new location or requested a telephone number change. When callers dial the former number they are routed to a prerecorded message which informs the caller of the new number. This service is provided free of charge for an initial period of 30 days for residential customers and for 180 days or the life of the directory, whichever is longer, for business customers. Up to three additional months are available for a one time charge for each month (See Rates and Charges, III.C. following).

D. LIVE OPERATOR FEE

In addition to other operator service charges set forth in this section (or wherever the other operator service charges reside in the tariff), a Live Operator fee is applied when the customer chooses to speak with a live operator. The customer is informed by the automated system of the applicable charges prior to connection to the operator. The charge will be collected at the time of payment processing.

This fee will not apply if:

- The automated payment systems are unavailable due to system outages.
- Customer is requesting a call to an emergency service.
- Call cannot be made by the automated system.

(N)



(N)

Effective: March 1, 2018

---

OPERATOR SERVICES

I. RESERVED FOR FUTURE USE

(T)

(D)

(D)



Effective: October 19, 2016

---

OPERATOR SERVICES

II. SPECIAL CONDITIONS

A. METHOD OF APPLYING RATES

1. Operator Handled Service

(a) Charges for all classes of telephone calls are billed against or collected from the calling telephone number. However, upon request, calls between points within the Frontier Calling Area may be placed on a non sent-paid basis and toll charges may be:

- Billed against or collected from the called telephone number, except a coin telephone number and a COPT telephone number (i.e., charges may be reversed) if the charges are accepted at the called station.
- Billed against or collected from a third telephone number or account, except a coin telephone number and a COPT telephone number anywhere in the United States or Canada where such billing is accepted at the third telephone.
- Exception - California Relay Service calls may only be billed to a third number within California.
- Billed against another telephone company (credit) calling card account when the party requesting such billing is authorized to use such (credit) calling card.

(1) Calling Card Service (Direct Dialed) applies when the originating call is completed without the assistance of an operator, where equipment is available. <sup>1</sup>

(2) This service also applies to calls that require operator assistance <sup>2</sup> which is limited to entering the Calling Card number to complete the call and recording the Calling Card number for billing purposes.

(3) This service also applies to calls that require operator assistance to:

- a. Place a Calling Card operator station service call when equipment capability precludes the foregoing.
- b. Place a Calling Card operator station service call for customers who identify themselves as being handicapped and unable to dial.

<sup>1</sup> This service also applies to calls placed from a public telephone.

<sup>2</sup> Charges are applicable only to calls placed originally as a Direct Dial Calling Card call and not applicable to collect or third number billing on which the "billed-to-number" person accepts the charges, but requests the charges be billed to a Calling Card. The applicable charge for the latter two calls is the Operator Handled Station-to-Station charge.

(L) Item II.A. relocated from Sheet 3.

(L) Item II.B. relocated to Sheet 5.

(L)

(L)

(N)

(N)

OPERATOR SERVICES

II. SPECIAL CONDITIONS (Continued)

B. NUMBER REFERRAL SERVICES

1. Number Referral Services are offered to customers where facilities permit.
2. The disconnected or changed number will be kept dedicated for the customer's selected referral period unless the Company determines it necessary to reassign and use the referred number as specified in the General Exchange Tariff, Schedule D&R, Rule No. 8.
3. If the Company initiates the number change, the number referral service will be provided free of charge only for a period of 30 days.
4. Credit allowance or refunds will only be provided as applicable for an incorrect referral due to the Company's error (such as no referral when one was requested) or for situations in which the Company needs to use a referred number before the customer requested period has been reached. The credited amount will be based on the actual number of days the number referral service was not provided. To determine the credit allowance for a fraction of a month, every month is considered to have 30 days. The limitation of the Company's liability is set forth in Section 2 of this Product Guide.
5. If a telephone number change is initiated due to a high volume of misdirected calls, number referral (Basic Referral) will be provided at no charge for a period of three months.

III. RATES AND CHARGES

A. Operator Handled Service Charges

	<u>Charge Per Call</u>	
1. Operator Handled Credit/Calling Card Calls (Direct Dialed), per message <sup>1</sup>		
(a) Commercial Credit Card <sup>2</sup>	*	(C)
(b) Interexchange Carrier Calling/Credit Card <sup>2</sup>	*	
(c) Local Exchange Carrier Calling Card	*	
2. Operator Handled Station-to-Station		
(a) Direct Dialed	*	
(b) Coin Sent-Paid	*	
(c) Corrections Collect Service, per message <sup>3</sup>	*	
3. Operator Handled Person-to-Person		
(a) Direct Dialed	*	
(b) Coin Sent-Paid	*	

B. Pay Station Service Charge

1. Non Sent-Paid Local or IntraLATA Toll Calls	*	(C)
--	---	-----

\* Services are provided by WiMacTel. Applicable rates can be found at <https://www.wimactel.com/tariffs/>.

<sup>1</sup> This charge is waived for California Relay Service (CRS) customers.

<sup>2</sup> Applicable where contractual arrangement exists between the Company and card issuers.

<sup>3</sup> Operator is mechanized; live operator is not provided.

(N)

Effective: May 26, 2023

---

OPERATOR SERVICES

III. RATES AND CHARGES (Continued)

C. Number Referral Services  
(See Special Conditions II.B.)

1. Basic Referral

Basic Referral is provided free of charge for an initial period of  
Residential - 30 days  
Business - 180 days or life of directory, whichever is longer

	Nonrecurring <u>Charge</u>	
a. Additional Month, or fraction thereof	\$100.00	(l)
b. Additional Two Months, or fraction thereof	100.00	(l)
c. Additional Three Months, or fraction thereof	100.00	(l)

D. Live Operator Fee

Nonrecurring  
Charge

Live Operator Fee, per occurrence

\*

\* Services are provided by WiMacTel. Applicable rates can be found at <https://www.wimactel.com/tariffs/>.

Effective: April 1, 2016

---

DIRECTORY SERVICES

TABLE OF CONTENTS

	<u>SHEET NO.</u>
I. DIRECTORY ASSISTANCE SERVICES	
A. Applicability	2
B. Territory	1
II. DIRECTORY ASSISTANCE CALL COMPLETION (DACC)	3
III. NATIONAL DIRECTORY ASSISTANCE SERVICE	4
IV. RATES AND CHARGES	5
V. TELEPHONE DIRECTORY SERVICE	
A. Applicability	6
B. Territory	6
C. General	6
D. Alphabetical	7
VI. NONLISTED NUMBER SERVICE	12
VII. WHITE PAGE DIRECTORY LISTINGS	12
VIII. RATES AND CHARGES	13
IX. LIST SERVICE	
A. Applicability	14
B. Special Conditions	14
C. Rates and Charges	14
X. SHARED SYSTEM LISTING SERVICE	
A. Special Conditions	15
B. Rates and Charges	15
XI. SUBSCRIBER LISTING INFORMATION	
A. Applicability	16
B. General	16
C. Special Conditions	16
D. Rates and Charges	17
XII. PUBLISHER LISTING FEES	
A. General	18
B. Rates and Charges	18

Effective: April 1, 2016

---

DIRECTORY SERVICES

I. DIRECTORY ASSISTANCE SERVICES

A. APPLICABILITY

Applicable to furnishing a calling party with telephone numbers or other information available from the Company's Directory Assistance records.

B. TERRITORY

Within the exchange areas of all exchanges, as listed in Section 4A, and within Local Access and Transport Areas (LATAs).

The call allowances and charges shown in RATES IV.1 and IV.2 herein only apply to calls placed to Directory Assistance requesting telephone numbers within the calling party's area code (NPA) or Local Access and Transport Area (LATA).

1. Directory Assistance Service provides the calling party with the following type information from the Company's Directory Assistance records:
  - a. The requested telephone number.
  - b. Requested telephone number information cannot be found.
  - c. The Directory Assistance operator will furnish up to a maximum of two items of the type of information above per call.
  - d. The business name and number may be provided after searching by a category or 'type of business' provided by the customer. Up to three business names are furnished from the random search. A maximum of two headings or categories can be searched per call.
    - With a 'type of business' search, the caller is billed for each category searched. The Local Directory Assistance rate applies for both local and national businesses searched.
    - Charges are applicable if no listings are found or if the listings found are non-published.
2. Application of Directory Assistance Service Call Allowance
  - a. Any portion of a Directory Assistance Service call allowance which is unused during a billing period may not be used in another billing period nor can an unused portion be transferred from one account to any other account.
  - b. If Direct Outward Dialing (DOD) or Direct Inward Dialing (DID) are provided with a trunk-line service, the call allowance applies to each trunk furnished.
  - c. The rates and allowances for Directory Assistance Service apply to FX customers who are provided dial tone by this Company.
  - d. Customers who make operator assisted calls to Directory Assistance will be charged the applicable rate for Directory Assistance plus the surcharge for an operator assisted station message, as set forth in Section 20, Operator Services, of this Product Guide.

Effective: April 1, 2016

---

DIRECTORY SERVICES

I. DIRECTORY ASSISTANCE SERVICES (Continued)

B. TERRITORY (Continued)

3. The following are provided an unlimited allowance and are exempt from Directory Assistance charges:
  - a. A person with a physical disability which limits use of a telephone directory may be granted an exemption by the Company by completing a Company provided exemption form.
  - b. A residence service is exempt if the service is used by anyone who is certified to have a physical disability which limits using a telephone directory.
  - c. A business service is exempt if the proprietor of the business and all regular employees of the business have been certified in accordance with 3.a. above, or if the service is provided to an organization established specifically for the purpose of assisting with severe seeing disabilities. Such an organization may employ the services of both certified and non-certified individuals. This exemption does not apply to customers connecting COPTs to the Company's network.
  - d. Certified individuals who make Directory Assistance calls from any telephone and charge the calls to an exempt telephone number or calling card. This exemption does not apply to customers connecting COPTs to the Company's network.
  - e. Customers whose lines are not equipped with Automatic Number Identification (ANI).

Effective: April 1, 2016

---

DIRECTORY SERVICES

II. DIRECTORY ASSISTANCE CALL COMPLETION (DACC)

1. Directory Assistance Call Completion (DACC) provides an incoming Directory Assistance customer requesting an intraLATA number a mechanized announcement offering call completion to the listed number requested. The call is completed on a sent-paid basis (paid for by the calling customer). The DACC charge applies only to calls that are answered.
2. The mechanized announcement will instruct the caller that for an additional charge, the call will be automatically completed by depressing a specific digit on the touch-tone key pad. All completed calls will incur the DACC charge. Customers may request blocking of DACC calls originating from their telephone lines by contacting the Company's business office.
3. DACC charges will be applicable to persons with a visual, physical, or reading handicap.
4. DACC will be furnished only where facilities and operating conditions permit.
5. DACC will not be provided to the following services:
  - 800 Service
  - 976 Service
  - 900 Service
6. This service is furnished solely for the telephone calling purposes of the caller.
7. Provisions concerning limitations of liability and allowance for interruption of service are as set forth in Section 2 of this Product Guide and in the General Exchange Tariff, Schedule D&R Rule No. 21.
8. This offering provides call completion on a Local Access and Transport Area (LATA) basis.
9. DACC is not available with rotary dial service.
10. When a customer elects to have a call automatically completed to the number for which the Directory Assistance Listing was requested DACC, the charge shown under IV.3. Rates and Charges, will apply per completed call. The DACC charge is in addition to any applicable Directory Assistance and/or IntraLATA toll charges. Directory Assistance call allowances, as specified in this section do not apply to DACC
11. Calls will be completed on a sent paid basis. Person-to-person, collect, conference, calling card, third number or any other calls requiring operator handling are not included.
12. The Company assumes no responsibility or liability for any errors in the information furnished. The caller shall indemnify the Company and hold it free and harmless of and from any and all claims, demands or damages that shall arise from the use of the service.

Effective: April 1, 2016

---

DIRECTORY SERVICES

III. NATIONAL DIRECTORY ASSISTANCE SERVICE

1. National Directory Assistance Service is available to business and residence customers who request directory assistance listings outside their Local Access and Transport Area (LATA).
2. A maximum of two requested telephone numbers will be provided for each National Directory Assistance call.
3. Customers who make operator handled calls to National Directory Assistance will be charged the applicable rate for National Directory Assistance plus the service charge for an operator handled station message, as set forth in the Section 20, Operator Services, of this Product Guide.
4. National Directory Assistance Service will be furnished only where facilities and operating conditions permit.
5. Local Directory Assistance call allowances as specified in this Product Guide do not apply to National Directory Assistance. There will be no call allowances associated with National Directory Assistance Service.
6. The Company will not release nonpublished listings except where a listing may be already disclosed in another telephone company published directory or directory database.
7. The Company assumes no responsibility or liability for any errors in the information furnished. The caller shall indemnify the Company and hold it free and harmless of and from any and all claims, demands or damages that shall arise from the use of the service.



DIRECTORY SERVICES

IV. RATES AND CHARGES

	<u>Rate Per Call</u>	
1. Residence Service and California Lifeline Telephone Program, each line <sup>1</sup>	*	(C)
2. Business Service <sup>1</sup>		
a. Individual Line Service, each line	*	
b. Trunk-line Services, each trunk	*	
c. Centrex Service, each station line	*	
d. All Other Services (Marine Service, Mobile, etc.), except connections for COPT vendors, each line	*	
e. COPT Providers (operator assisted calls), each line connecting COPT to network	*	
f. COPT Providers (directly dialed calls), each line connecting COPT to network	*	
3. Directory Assistance Call Completion (DACC), each call completed	*	
4. National Directory Assistance, each call <sup>1</sup>	*	(C)

\* Services are provided by WiMacTel. Applicable rates can be found at <https://www.wimactel.com/tariffs/>.

<sup>1</sup> Callers may request second and third listings by remaining on the line.

Effective: April 1, 2016

---

DIRECTORY SERVICES

V. TELEPHONE DIRECTORY SERVICE

A. APPLICABILITY

Applicable to telephone directory services, composed of Alphabetical Directories, and to Interexchange Carrier (IC) Information Listing in the "dialing instructions" section of the white pages in the telephone directory.

B. TERRITORY

Within the exchange areas of all exchanges, as listed in Section 5 of this Product Guide, Sheets 2 and 3.

C. GENERAL

1. Telephone directories containing alphabetical listings for the local and ZUM areas as set forth in Product Guide, Section 4A (Local Exchange and EAS) shall be provided upon customer request without charge.
2. Tariffs and this Product Guide of the exchange served by a directory shall be applicable to the alphabetical listings appearing therein.
3. Public telephones will not be listed.
4. Under provision of Section 384 of the Penal Code, every telephone directory published and distributed to the general public after September 11, 1957, shall have the following notice:

WARNING

The Penal Code of the State of California provides that any person who shall willfully refuse to immediately relinquish a line when informed that such line is needed for an emergency call, and in fact such line is needed for an emergency call, to a fire department or police department or for medical aid or ambulance service, or any person who shall secure the use of the line by falsely stating that such line is needed for an emergency call, shall be guilty of a misdemeanor. "Emergency" as used above means a situation in which property or human life is in jeopardy and the prompt summoning of aid is essential.

5. A trade name may be used as the name portion of either additional or primary listings. The Company may require the customer to furnish evidence satisfactory to the Company that he is authorized to use the Trade Name described in the listing furnished, and that the business is actually being conducted under that name.  
  
If, upon request of the Company, the customer for any reason does not furnish such evidence, the Company may refuse to list the name or refuse to continue a listing of the name. Acceptance or refusal of the Company to accept a listing is subject to review by the Public Utilities Commission of the State of California.
6. The customer assumes full responsibility concerning the right to use any name, address, or trade name in a directory listing acceptable to the company.
7. The customer assumes full responsibility in determining that any name, address or trade name listed will conform in all respects to all applicable law and all licensing requirements from state or any local licensing authority.

Effective: April 1, 2016

---

DIRECTORY SERVICES

V. TELEPHONE DIRECTORY SERVICE (Continued)

C. GENERAL (Continued)

8. The customer agrees to indemnify and hold the Company harmless from any claims, loss, damage or liability, which arises out of or results from the use by the customer of a listing containing a name, address or trade name or with respect to or related to g. and h. above.
9. Except as otherwise provided in this section, the Company does not undertake to determine the legal, contractual or any other right to the use of a name, address, or trade name. Nor does the Company undertake to determine whether a customer is required to have a valid occupational or business license, permit or registration from the State of California or any local licensing authority in order to engage in the business listed.
10. Nonpublished and Nonlisted telephone numbers may be displayed to customers who subscribe to Calling Number Identification (CNID) Service. Nonpublished and Nonlisted customers may elect to utilize Complete or Selective Blocking (Section 6 of this Product Guide), which will block display of the telephone number to the called party. (See the General Exchange Tariff, Schedule D&R, Rule No. 37.)

D. ALPHABETICAL

1. Listings in the alphabetical sections of the telephone-directories are intended solely for the purpose of identifying customers' telephone numbers as an aid to the use of telephone service.
  - a. One listing will be provided without additional charge for each individual line, each private branch exchange, each telephone answering service, each call receiving service, each Centrex service, or each number in rotary sequence.
  - b. The rate for foreign exchange service includes primary listings, without additional charge, in the directories serving the foreign and local exchanges.
  - c. The rate for a Radio Telephone Company's bonafide mobile radio customers using the telephone number of the Company's base stations, or an individually assigned telephone number shall be that of an additional listing.
2. Rates for listings in other directories, additional listings and lines of information begin the day the listings are entered in the information records. When such listings are included in a directory, the charges will be discontinued only at the end of the publication period for that directory, and then only if notice is received on or before the closing date of the next directory; also, charges will be discontinued if the listed party vacates the customer's premises or subscribes to service of the same class furnished the customer, or if service to the customer or listed party is discontinued.
3. For liability and allowance for listing errors or omissions see Section 2 of this Product Guide and the General Exchange Tariff, Schedule D&R, Rule No. 21.
4. All applications for additional listings and lines of information shall be made by the customer or an authorized agent of the customer, except that reference to the service of another customer shall first be authorized by such other customer. Such authorization may be withdrawn effective at the end of any directory period provided such notice is received by the Company on or before the closing date of the new directory.

Effective: April 1, 2016

---

DIRECTORY SERVICES

V. TELEPHONE DIRECTORY SERVICE (Continued)

D. ALPHABETICAL (Continued)

5. Additional listings in connection with the customer's service must bear the same address and telephone number as the customer's primary listing with the following exceptions:
  - a. No address is included in either of the types of reference listings under VIII. Rates and Charges 2.d and 2.e and no address or telephone number is included in cross reference listings, 2.f.
  - b. Additional listings in connection with service not located on the same premises as the primary service may show the address at which the service is located, except that the address may be omitted from the listing when the customer does not publicly conduct business at the address at which the service is furnished. The name portion of the listing shall include a reference to the name shown in the primary listing.
  - c. Additional listings in connection with Centrex or inward dialing stations may show the address of either the pilot number or the location of the station, but will show the telephone number of that Centrex or inward dialing station.
  - d. Additional listings in connection with foreign exchange service will not be permitted to show the address of an extension station provided only for answering purposes.
  - e. Upon the customer's request, the address may be substituted with one of the following:
    - (1) Post office box address within the same local area.
    - (2) Off premise extension address.
    - (3) Remote Call Forwarding address.
    - (4) The address may be omitted from the directory.
  - f. The rate for an additional line of information is also applicable if address information results in an extra line.
6. A line of information may consist only of descriptive information acceptable to the Company.
7. The number for facsimile/computers used in connection with telephone lines may be listed as such in a caption arrangement upon customer request.
8. Each business listing shall reasonably identify the particular person or firm to whom the service is furnished.

Effective: April 1, 2016

---

DIRECTORY SERVICES

V. TELEPHONE DIRECTORY SERVICE (Continued)

D. ALPHABETICAL (Continued)

9. Business service primary listings consist of a name, designation, address and telephone number in accordance with the following:

(a) Name - The name must be the name under which the customer is publicly conducting business and may be either the name of an individual, firm, company, corporation or association. Listings in an individual's name may include professional titles, abbreviations indicating degrees of profession or scholarship, or abbreviations indicating affiliation with a business or professional group, organization or association. Acceptable titles are those by which a person is commonly addressed or recognized by the general public.

(b) Designation - A designation descriptive of the business or profession may be included in the listing.

(c) Address - The address may be that of the premises on which the primary station, extension station, PBX attendant's position, PBX station, Centrex, telephone answering service, answering line or secretarial line is located, or from which the mobile equipment of the business operates; or the address where calls are forwarded in conjunction with Remote Call Forwarding service. The address may be omitted or a post office box address or the address of a private postal service within the same local service area may be substituted upon the request of the customer, except where the type of business generally involves the removal of appliances, furniture or articles of value from the owner's premises, or where required by law, the address at which the customer is conducting business must be included in the business listing. The address may include a sublocation such as suite number or apartment number.

(d) Telephone Number - The listed telephone number shall be that assigned to the telephone service.

When caption arrangements are used, the main caption listing must fulfill the requirements set forth under 9. above.

10. Business additional listing under VIII.Rates and Charges 2.a and cross- reference listings under VIII.Rates and Charges 2.f may be of the following classification:

(a) Those members of firms, the officers of corporations or the names of employees, departments or branches of the customer's business, etc. Departments or branches will be included under the primary service listing only. A listing may include the name portion of the primary listing and also the same business designation descriptive of the connection with such name.

(b) Other names under which the business of the customer may be known to the public where such name is applicable to identically the same business operation in scope and character as that covered by the primary service listing.

(c) A cross reference listing will include a name and reference to another listing which would carry the telephone number. This type of listing may be furnished at the option of the Company at no charge when it appears necessary in connection with telephone service in general, provided the listing would have no value to the customer.

Effective: April 1, 2016

---

DIRECTORY SERVICES

V. TELEPHONE DIRECTORY SERVICE (Continued)

D. ALPHABETICAL (Continued)

10. Business additional listing under VIII.Rates and Charges 2.a and cross- reference listings under VIII.Rates and Charges 2.f may be of the following classification: (Continued)

(d) A listing under Special Condition 10.(d) will be furnished only where there is sufficient evidence that the business may be known to the public under such name, provided that (1) the listing has not been designed solely to secure preferential location in the alphabetical or classified section; (2) the principles of shared system listing service are not violated; (3) the inclusion of such listing in the telephone directory will aid other telephone customers in locating the customer to the telephone service.

11. Listings and lines of information under VIII.Rates and Charges 2.and 3., are available in connection with listings furnished under VIII.Rates and Charges 1.

12. (1) Residence primary listings or additional listings shall consist of the following:

(a) Name

Individual(s) listed must reside on the premises at which service is furnished and the name(s) shall be that as commonly used by the individual(s) for identification for regular business and social purposes. The Company may require proof that the name requested is the name by which the individual is known and the name that the individual commonly uses.

The name(s) may be:

- That of an individual.
- A combination of names and/or initials of two persons with the same surname.
- Another given name and/or initials for a person known by more than one name.
- For the purpose of identification, a residence listing of a professional customer may include an abbreviation indicating a professional title or scholastic degree.

(b) Address

The address shall be that of the premises at which service is furnished except, upon the customer's request,

- The address may be omitted from the directory.
- The United States post office box address within the same local service area.
- A private postal service address within the same local service area.
- The substitution of a different city name within the same local service area is permitted.

(c) Telephone Number

The listed number shall be that assigned to the telephone service.

Effective: April 1, 2016

---

DIRECTORY SERVICES

V. TELEPHONE DIRECTORY SERVICE (Continued)

D. ALPHABETICAL (Continued)

12. (Continued)

- (2) Residence listings may include a title or abbreviation acceptable to the Company to assist in listing identification when the customer is dealing in medical emergency services.

Residence listings for other than those individuals dealing in medical emergency services may include an abbreviation indicating a professional title or scholastic degree acceptable to the Company.

- (3) Residence additional listing may be those of the customer or members of the customer's domestic establishment residing on the premises on which the customer's service is furnished.
- (4) Listing for Centrex dormitory stations are treated as residence additional listings and are charged for under VIII.Rates and Charges 2.b., following.
- (5) The rate for non-published and non-listed services does not apply to the following:
- (a) Customer with a Published Listing - If a customer has both published and non-published/non-listed listings for the same address and class of service, the non-published/non-listed monthly recurring charge will not apply.
  - (b) Customer with a Non-Published/Non-Listed Listing - If a customer has a non-published/non-listed listing, only one monthly recurring charge will be applied for any non-published and/or non-listed listings for the same customer with the same class of service at the same address. If the customer has a combination of non-published and non-listed listings at the same address, the non-listed monthly recurring charge will apply.
  - (c) Pay Telephone Service
  - (d) Special Reversed Long Distance Service
  - (e) Foreign Exchange/Zone Service
  - (f) Temporary Service (service provided for a period of not more than 30 days)
  - (g) Special services such as teletypewriters or data services provided for customers with impaired hearing having a limited requirement for voice communication.
  - (h) Local Exchange Service for customers living in a hotel, hospital, retirement complex, or boarding house provided the customer is listed under the telephone listing of the establishment.
  - (i) New listings provided to a customer because of unusual circumstances, such as harassing calls, threat, or other acts adversely affecting the health, welfare, security or service of the customer (service provided for a period of not more than 30 days).

Effective: April 1, 2016

---

## DIRECTORY SERVICES

### VI. NONLISTED NUMBER SERVICE

Directory Nonlisted Number Service is an arrangement whereby a subscriber's telephone number is omitted from the telephone directory but is listed with Directory Assistance.

When Directory Nonlisted Number Service is furnished, the customer will hold the Company harmless from any damages which might arise and absolve the Company from any responsibility for the failure of the customer to receive calls because of the nonlisted arrangement.

Subscribers to Directory Nonlisted Number Service will be required to maintain such service until the first issuance of a directory in which a requested change may be published, or until telephone service is discontinued. Billing for such services will be discontinued with the last regular bill dated before the issuance of the directory in which the change is made.

### VII. WHITE PAGE DIRECTORY LISTINGS

White page directories include business listings, local emergency numbers and local government pages.

Residential white pages listings are available free of charge to residential customers upon request. \*You may request the listings, in print form or on CD-ROM, by calling 1-800-888-8448. Once requested, the listings, in addition to periodic updates, will be delivered to you by United States Postal Service until you cancel, move to a new address or make a change to your listing. Upon moving or changing your listing, you must renew your request by calling the number above.

In addition, residential white pages listings are available online at <http://frontier.com/whitepages>.



Effective: April 15, 2024

DIRECTORY SERVICES

VIII. RATES AND CHARGES

	<u>Monthly Rate</u>	
1. Primary service listing in a directory other than that of the serving exchange when furnished at the customer's request, each (Foreign Listing Services)		
a. Business	\$6.50	
b. Residence	\$5.00	
2. Additional listings		
a. Business, each	\$24.00	(I)
b. Residence, each	\$5.50	
c. Guests of hotel, each		
Business	\$5.25	
Residence	\$3.45	
d. Reference to another service of the customer, each		
Business	\$5.25	
Residence	\$3.45	
e. Reference to service of another customer, each		
Business	\$5.25	
Residence	\$3.45	
f. Cross-reference listing, each		
Business	\$5.25	
Residence	\$3.45	
g. Line of information, each		
Business	\$24.00	(I)
Residence	\$5.00	
3. Nonpublished Listing Service	\$4.00	
4. Directory Nonlisted Number Service	\$5.50	

Effective: April 1, 2016

---

DIRECTORY SERVICES

IX. LIST SERVICE

A. APPLICABILITY

Applicable to furnishing telephone numbers in written form from the alphabetical section of telephone directories.

B. SPECIAL CONDITIONS

1. List Service consists of searching for listings and matching telephone numbers to one or more names and addresses supplied by the customer and furnishing such information in written form to the customer. These telephone numbers shall be obtained from listings included in the alphabetical section of the regular telephone directories which are normally available to the Company's operator services personnel. This service contemplates furnishing telephone numbers in effect at the time a request is received only. A request to verify or update telephone number information previously furnished shall be charged for as an initial request for service.
2. One area code charge is applicable for each area code involved in a request for list service for which a telephone number listing is provided.
3. This service is furnished solely for telephone calling purposes of the customer. The customer shall not sell, reprint, lease, rent or permit the use of this information by others.
4. The Company assumes no responsibility or liability for any errors in the information furnished. The customer shall indemnify the Company and hold it free and harmless of and from any and all claims, demands or damages that shall or may arise from the use of this Product Guide.
5. Where a name supplied by a customer is included in a caption listing arrangement and a single telephone number can clearly be associated with it, only that telephone number will be furnished; otherwise all telephone numbers included in that caption arrangement will be furnished at the charge shown above.

C. RATES AND CHARGES

	<u>Nonrecurring Charge</u>
Each Area Code	\$15.90
Each Listing Searched	.25

Effective: April 1, 2016

---

DIRECTORY SERVICES

X. SHARED SYSTEM LISTING SERVICE

A. SPECIAL CONDITIONS

1. Shared System Listing service is an arrangement whereby an individual, firm, corporation or association shares in the use of a customer's telephone service.
2. The rate for a Shared System Listing includes a listing in the alphabetical and classified directories, and applies in addition to rates and charges for other service provided.
3. Shared System Listing service will be billed to the customer of the Company.
4. Shared System Listing service will be provided when an application is made by the customer and any one of the following conditions exists.
  - a. Application is for the use of the customer's service by an individual, firm, company or association doing business under a separate name and occupying jointly, or in part, the premises on which the customer's primary or off premises service is located.
  - b. Application is for the use of the customer's service for another business publicly conducted by the customer and differing in character and in name from the business for which the facilities are furnished.
  - c. Application is for service to be furnished over the facilities utilized in furnishing service to the customer, in the name of another individual, firm, company, corporation, or association represented by the customer and the use of the name to be listed is authorized by the owner of the name.
5. Signatures of the customer of the Company and the Shared System Listing applicant sharing the service are required to establish a Shared System Listing.
6. The minimum charge for Shared System Listing service shall be the monthly rate. If the listing is included in the telephone directory, the charge will continue until the end of the directory period unless:
  - The person(s) sharing the service vacates the customer's premises;
  - The customer's service is discontinued;
  - If, for a business, the business for which the listing service is provided is discontinued at the customer's premises.
7. The Shared System Listing may carry the same telephone number listed for the customer, or; when separate lines, trunks or groups of lines in rotary sequence, or station lines of a DID system are assigned, these numbers may be contained in the listing.
8. Special conditions as set forth in this Section are applicable to Shared System Listing service unless otherwise specified herein.

B. <u>RATES AND CHARGES</u>	<u>Nonrecurring Charge</u>	<u>Monthly Rate</u>
Shared System Listing (SSL) associated with individual line service, and trunk line services, each listing	1	\$ 2.80

<sup>1</sup> Appropriate Service Order Charges in Section 3 of this Product Guide are applicable.

---

DIRECTORY SERVICES

XI. SUBSCRIBER LISTING INFORMATION

A. APPLICABILITY

Applicable to directory publisher access to Utility's Subscriber Listing Information (SLI).

B. GENERAL

1. The Utility will supply Publishers with the names, addresses, telephone numbers and primary advertising classifications (if any) of the Utility's telephone subscribers for locations requested by Publisher and updates to this information.
2. Subscriber Listing Information (SLI) and Updated Subscriber Listing Information (Updated SLI) shall not include information for subscribers whose telephone numbers are unlisted or unpublished.
3. Subscriber Listing Information and Updated Subscriber Listing Information are available by Utility Directory Name, Exchange and NPA/NXX, customer segmentation (e.g., business, residential) and for Updated SLI, by service order type (e.g., installation, change).
4. For distribution purposes only, service addresses are available as a separate chargeable option with the SLI Basefile. Service addresses can be provided with Updated SLI as an option to customers at no extra charge. <sup>1</sup>
5. Charges listed in VIII.Rates and Charges do not include applicable surcharges, sales or similar tax, which will be added.

C. SPECIAL CONDITIONS

1. Information ordered is supplied in either compact disk (CD) or hard copy print-out as selected by Publisher. Updates are also available through Internet access.
2. Updates will be provided on a daily, weekly or monthly basis as elected by the Publisher.
3. Orders for listing information must be submitted in writing (facsimile acceptable) on the Utility order form. Publisher must allow thirty (30) days processing time in advance of the desired date for the information.
4. Requests must specify the date the SLI should be pulled from the directory listings database, and for Updates, the begin and end dates information should be provisioned. Also to be specified are the directory names, exchanges, NPA/NXXs, listing types desired, the medium for provision of the Listing Information, and the address for delivery.
5. The Utility will invoice Publisher subsequent to provision of the listing information. Publisher agrees to pay the invoice within 45 days of receipt.

<sup>1</sup> If a Publisher requests service addresses for unpublished and unlisted subscribers, this will be provided, for the Publisher's directory distribution purposes only, at the same rate as SLI Basefile or Updated SLI, as required, by Decision No. 97-01-042 issued January 24, 1997.

Effective: April 1, 2016

---

DIRECTORY SERVICES

XI. SUBSCRIBER LISTING INFORMATION (Continued)

C. SPECIAL CONDITIONS (Continued)

6. SLI and Updated SLI are provided solely for the purpose of publishing directories. Publisher agrees not to distribute or sell the listing information to any third party, and agrees not to sublicense or assign any right acquired by Publisher under this Product Guide. No right or license is granted or implied under any proprietary rights of the Utility or affiliates that subsist in portions of directories distributed by or for the Utility other than SLI and Updates. Publisher certifies that the listing information shall be used only for the purpose of publishing directories.
7. The Utility's liability shall be limited to direct and actual damages which shall not exceed the fees paid by Publisher for the information provided by the Utility. Under no circumstances shall the Utility be responsible or liable for indirect, incidental, special or consequential damages, including, but not limited to, economic loss or lost business or profits.
8. Listing Information is supplied as is. The Utility makes no warranty of any kind, express or implied, including without limitation warranties of merchantability or fitness for a particular purpose.
9. Publisher agrees to indemnify, defend, and hold harmless the Utility, its affiliates, officers, agents, and contractors (collectively, the "Indemnified Parties") from all losses, claims, demands, damages, expenses, suits, or other actions, or any liability whatsoever, including, but not limited to, costs and attorney's fees, suffered, made, instituted, or asserted by any third party arising from a Publisher's use of the listing information provided as requested.

D. RATES AND CHARGES

Subscriber Listing Information (SLI)

SLI Basefile	\$ 0.04 per listing
Updated SLI	0.06 per listing
Minimum Fee	

There will be a minimum fee of \$100.00 for each Full File Extract listings request fulfilled by Company. The minimum fee of \$100.00 for Service Order Activity is based on the combined monthly fee for each Service Order Activity request.

Effective: April 1, 2016

---

DIRECTORY SERVICES

XII. PUBLISHER LISTING FEES

A. GENERAL

1. A CD-ROM Processing Fee will apply to all full directory listing extracts and service order update requests. CD request fulfillments will be shipped via overnight UPS. Single shipments containing multiple CDs will be charged a single processing fee.
2. A Report Fee will apply to listing extract statistical report(s) requests. Listing Reports will include total listing counts by NPA, NXX, Listing Type and Class of Service. Jobs that require multiple extracts requiring the production of multiple reports may be assessed a separate Report Fee for each extract. Reports are delivered via email.
3. An Expedited Order Fee may apply to full directory listing extracts and service order update requests that require fulfillment in a time frame less than 30 (thirty) days from the request submission date. The fee will apply if the fulfillment of the expedited request requires reprioritization that could jeopardize on-time fulfillment of existing orders, or require employee overtime. Such assessment will be made by Frontier personnel. The Expedited Order Fee will be charged in conjunction with the Minimum Order Fee when a minimum order is requested to be fulfilled in less than thirty (30) days.
4. A Cancellation Fee will apply to full directory listing extracts and service order update orders that are canceled more than seventy two (72) hours after receipt. Cancellation fees will post as a Minimum Charge.
5. The Late Payment fee will be applied to invoices that have not been paid at or within thirty (30) days after the billing date. An interest charge on the unpaid balance will be assessed by Frontier at a rate not to exceed 12% per annum or the highest rate permitted by law, whichever is lower. In the instance that an unpaid invoice is the subject of a bona fide dispute of the billed amount, the customer must notify Frontier of the dispute in writing within sixty (60) days after receipt of the invoice or the dispute shall be waived.

B. RATES AND CHARGES

CD-ROM Process Fee	\$25.00
Report Fee	20.00
Expedited Order Fee	100.00
Cancellation Fee	100.00

Effective: April 1, 2016

---

SERVICES FOR ENHANCED SERVICE PROVIDERS (ESP)

TABLE OF CONTENTS

	<u>SHEET NO.</u>
I. APPLICABILITY	1
II. TERRITORY	1
III. SPECIAL CONDITIONS	
A. Definitions	1
B. General	2
IV. RATES AND CHARGES	6

Effective: April 1, 2016

---

SERVICES FOR ENHANCED SERVICE PROVIDERS (ESP)

I. APPLICABILITY

Applicable to the provision of certain network services, which expand a customer's ability to provide services to clients or which provide benefits directly to the customer.

II. TERRITORY

Within the exchange area of all exchanges, as the exchange areas are listed in Section 5, Sheets 2 and 3.

III. SPECIAL CONDITIONS

A. Definitions

1. Enhanced Service Provider (ESP). A customer of the Company who provides Enhanced Services, which are defined as services, offered over Local Exchange Carrier, i.e., Company, exchange and transmission facilities used in intraLATA communications, which employ computer processing applications that act on the format, content, code, protocol or similar aspects of the subscriber's transmitted information; provide the subscriber additional, different, or restructured information or involve subscriber interaction with stored information. (A customer of an ESP is, in turn and with respect to this section of the guide, a client.)
2. Message Waiting Indication--Audible service sends an identifiable tone (such as a stutter dial-tone) to an ESP's client whenever messages for the client are waiting in storage.
3. Forwarded Call Information--Intraoffice service provides information relating to calls incoming to an ESP client and outgoing from the client to the ESP, if the client's line is arranged for any call forwarding service which forwards calls to an ESP. The information relating to calls includes the client's number, call-forwarded number and the reason (busy or no-answer condition) for calls being forwarded.
4. Data Link service provides the capability to deliver Forwarded Call Information to an ESP.
5. User Transfer service provides a customer subscribing to trunk lines or station lines used in conjunction with an ESP's equipment with the ability to place on hold an established call and originate a second call to a third party. After a call has been transferred, the original line or trunk is cleared for further use.
6. Queuing service is a supplement to rotary service, which places calls in queue while waiting to be answered when all terminals in a hunt group are busy. Queuing service is provided only in conjunction with lines arranged for rotary service.
7. Call Forwarding Busy-Line--Fixed is a permanently activated service which automatically redirects calls placed to a customer's or a customer's (such as an ESP's) client's telephone number to another telephone number subscribed to by the Company's customer, if the caller encounters a normal busy-line condition.
8. Call Forwarding No-Answer--Fixed is a permanently activated service which automatically redirects calls placed to a customer's or a customer's (such as an ESP's) client's telephone number to another telephone number subscribed to by the Company's customer, if the caller encounters a no answer condition after a specified number of rings.



Effective: April 1, 2016

---

SERVICES FOR ENHANCED SERVICE PROVIDERS (ESP)

III. SPECIAL CONDITIONS (Continued)

A. Definitions (Continued)

9. Call Forwarding Busy Line Don't Answer is a permanently activated service which automatically redirects calls placed to a customer or a customer's (such as an ESP's) client's telephone number to another telephone number subscribed to by the Company's customer, if the caller encounters either a no-answer condition after a specified number of rings or a normal busy-line condition.
10. Customer Controllable Ringing (CCR). A service that provides customers with the ability to adjust the number of ring cycles that are used prior to forwarding a call in a No Answers situation. To select the number of rings desired (1-9), the customer will dial a special access code and then input a digit that corresponds to the number of ring cycles desired before the forwarding takes place.
11. Message Waiting Indication - Audible Ring Burst (ARB). A service that provides ringing at a special cadence to signal the customer that a message is waiting. This reminder will be repeated at a specific interval programmed by the Company. This is in addition to the stutter dial tone that normally represents a message waiting.
12. Enhanced Call Transfer. Enhanced Call Transfer allows the user of a 2-way trunk with DID to transfer any incoming call to another line or trunk outside of the system and then to leave the connection without disconnecting the call. Enhanced Call Transfer is offered to customers who have existing digital facilities. Customers requiring additional digital facilities must purchase them separately from the Facilities for Intrastate Access Tariff C-1.
13. Message Waiting Indication-Visual. Message Waiting Indication-Visual is a feature that provides the Enhanced Service Provider with the ability to send an alerting signal in the form of a light to its end user's line. This alerting signal can then be used by the Enhanced Service Provider to inform its end user that a message(s) is waiting.
14. Inter-Switch Voice Messaging (ISVM). Inter-Switch Voice Messaging (ISVM) service is available to Enhanced Service Providers (ESPs) who subscribe to Data Link service and individual-line business service, trunk-line business service, or Centrex service. Data Link service operates on an intra-switch basis only. This service, combined with ISVM service, enables voice mail and call answering capabilities to be extended via intra- and inter-switch connectivity, thereby allowing the ESP to serve clients within a Local Access Transport Area (LATA).

B. General

1. Customers are responsible for the payment of rates and charges associated with establishing, continuing, and discontinuing or disconnecting services ordered on behalf of themselves and their clients.
2. The Company will not provide instructions for operating services of customers. Instructing clients is the responsibility of the customer.
3. The Company is not required to notify a customer (such as an ESP) when the Company disconnects a service subscribed to by another customer who is also the customer's (ESP's) client.
4. The Company will not disconnect or discontinue the services subscribed to by a customer who is also a client of another customer (such as an ESP) because of nonpayment of charges billed to the other customer. The Company will discontinue or disconnect services billed directly to a customer for nonpayment in accordance with the terms and conditions of the Company's Product Guide. The Company is not responsible for harm or damages to a customer or its clients resulting from services disconnected in accordance with the terms and conditions of this Product Guide.

Effective: April 1, 2016

---

SERVICES FOR ENHANCED SERVICE PROVIDERS (ESP)

III. SPECIAL CONDITIONS (Continued)

B. General (Continued)

5. Each customer and each customer's client shall indemnify, defend, protect, and save harmless the Company against any and all losses, claims, suits, demands, causes of action, damages, costs, or liability in law or in equity or every kind and nature whatsoever, including attorney's fees, arising directly or indirectly from the services provided in accordance with this product guide or in connection therewith, including but not limited to any loss, damage, expense, or liability resulting from any infringement or claim of infringement of any patent, trademark, or copyright, or resulting from any claim of libel or slander.
6. Each customer, not the Company, has responsibility and control over the content, quality, and characteristics of the services provides and conversations conducted over its equipment. The Company is not responsible for quality of, defects in, or content of the services which a customer provides its clients. The customer is responsible for complying with law, with rules and regulations of governmental agencies, and with the terms and conditions of the Company's product guide.
7. A customer may neither use the Company's name, signs, symbols, or markings nor implicate, implicitly or explicitly, the Company in any other way as a participant, promoter, or co-promoter, in sales media or other publicity, of services provided wholly by the ESP or jointly by the ESP and the Company, unless the customer first obtains written permission from the Company for each advertisement, announcement, or other informational media to be released.
8. Customers must agree to subscribe to a sufficient number of lines to maintain an average level of service, whereby no more than one call out of each one hundred call attempts will be blocked during the average busy hour of the busy week or the busy season, as measured at the Company's office.
9. Each customer subscribing to User Transfer service is responsible for the payment of applicable local calling, ZUM calling, or Message Toll calling charges for each completed call forwarded from its line to another line.
10. User Transfer (Call Transfer) is part of the standard Centrex services. Therefore, User Transfer rates from this section are not billed to Centrex customers.
11. Queuing is available to Centrex customers in accordance with the rates, charges, and conditions of Section 8 of this Product Guide.
12. Each customer, such as an ESP, ordering services from the Company on behalf of its customers (the customer's clients) is responsible for payment of all rates and charges associated with the services ordered. Should a client dispute the customer's authority, the customer will be held responsible for orders involving clients for whom no agency agreement exists.
13. A subsequent order charge, as specified for business and residence customers in Section 3 of this Product Guide for Frontier Calling Services, will be billed to the customer whenever services associated with a client's line and subscribed to by the customer on behalf of the customer's client are established.

Effective: April 1, 2016

---

SERVICES FOR ENHANCED SERVICE PROVIDERS (ESP)

III. SPECIAL CONDITIONS (Continued)

B. General (Continued)

14. The customer is responsible for placing orders for disconnecting or discontinuing services subscribed to on behalf of clients. Should a customer's client's telephone service be discontinued or disconnected for any reason, the Company will continue billing the customer for services subscribed to on behalf of the client until the customer requests that the service be disconnected or discontinued.
15. Customers ordering services on behalf of clients will not be charged for a subsequent order record charge for changing the customer's record.
16. Each customer and each client, directly or indirectly subscribing to a call forwarding service, is responsible for the payment of applicable local calling, ZUM calling, or Message Toll calling charges for each completed call forwarded from its line to another line.
17. Services available to Centrex customers from Section 11 of this Product Guide will be billed in accordance with the rates, charges, and conditions included in that section.
18. Centrex customers subscribing to CENPAC--Basic Control Package are not charged for changing the number of rings before calls are forwarded.
19. Each Call Forward service, each Message Waiting Indication service, and each Forwarded Call Information service and each package containing any of these services must be associated with a specific individual line, with a specific DID trunk-line telephone number, or with a specific Centrex station line from which calls are forwarded and to which calls are forwarded and to which is subscribed by a customer or a customer's client.
20. A customer must specify which services are to be associated with each client's telephone service.
21. Each customer providing voice message services must subscribe to either individual-line business services, trunk-line business services, or Centrex service for access to the Company's switched network. The network connection will be used to pass messages to and from the ESP's voice mail system.
22. Enhanced Call Transfer is available where facilities and conditions permit.
23. Inter-Switch Voice Messaging (ISVM)
  - a. ISVM is offered as an optional enhancement only to the Data Link service.
  - b. Customers subscribing to ISVM must also subscribe to Data Link service.
  - c. ISVM is offered subject to the availability of both Data Link and ISVM facilities.
  - d. The Company will determine which central office and transmission facilities are used to provide service.
  - e. Customers are entirely responsible for the compatibility of their terminating equipment to handle calls and call-related data.

Effective: April 1, 2016

---

SERVICES FOR ENHANCED SERVICE PROVIDERS (ESP)

III. SPECIAL CONDITIONS (Continued)

B. General (Continued)

23. Inter-Switch Voice Messaging (ISVM) (Continued)

- f. Signaling control and data communication protocols are defined by the Company and the Company retains the right to change these protocols.
- g. ISVM is available to compatible and suitably-equipped Centrex customers.
- h. The Company assumes no liability for the loss of stored messages or other information attributed to a failure of its facilities and equipment.
- i. The integrity of the customer's database information is solely the responsibility of the customer. The Company assumes no liability for any errors, misdirected calls, or misdirected message waiting indications resulting from problems with the customer's database. The Company will bill time and material charges to the customer to correct a condition on client's line as a result of the customer's incorrect database information.
- j. The Company assumes no liability for the loss of stored messages or other information attributed to a failure of its facilities and equipment.
- k. The integrity of the customer's database information is solely the responsibility of the customer. The Company assumes no liability for any errors, misdirected calls, or misdirected message waiting indications resulting from problems with the customer's database. The Company will bill time and material charges to the customer to correct a condition on client's line as a result of the customer's incorrect database information.

Effective: April 1, 2016

---

SERVICES FOR ENHANCED SERVICE PROVIDERS (ESP)

IV. RATES AND CHARGES

	<u>Nonrecurring Charge</u>	<u>Monthly Rate</u>
A. Message Waiting Indication--Audible, Per client line or DID number	1	\$0.50
B. Forwarded Call Information--Intraoffice, Per client line or DID number	1	1.00
C. Data Link, Per Data Link	\$1000.00	300.00
D. User Transfer, Per customer individual line or trunk line	1	1.75
E. Queuing, Per customer individual line or trunk line	1	1.50
F. Call Forwarding Busy Line--Fixed, Per client line or DID number	2	2
G. Call Forwarding No Answer--Fixed, Per client line or DID number	2	2
H. Call Forwarding Busy Line Don't Answer, Per client line or DID number	2	2

<sup>1</sup> See Section 3, Service Charges for nonrecurring charges.

<sup>2</sup> See Section 7, Custom Calling Services for monthly rates, and Section 3 of this Product Guide, Service Charges, for nonrecurring charges.

Effective: April 1, 2016

SERVICES FOR ENHANCED SERVICE PROVIDERS (ESP)

IV. RATES AND CHARGES (Continued)

	<u>Nonrecurring Charge</u>	<u>Monthly Rate</u>
I. Customer Controllable Ringing (CCR), Per client line or DID number	--	\$1.00
J. Message Waiting Indication - Audible Ring Burst (ARB), Per client line or DID number	--	1.50
K. Three-Service Package - Includes Call Forwarding Busy Line Don't Answer, Message Waiting Indication, and Forwarded Call Information, Per line or DID number	1	2.00
L. Five-Service Package - Includes Call Forwarding Busy Line Don't Answer, Message Waiting Indication, Forwarded Call Information - Intraoffice, Message Waiting Indication - Audible Ring Burst (ARB), and Customer Controllable Ringing (CCR)	--	2.75
M. Enhanced Call Transfer		
(1) per customer <sup>2</sup>	\$25.00	--
(2) per trunk	--	19.00
N. Message Waiting Indication - Visual, Per line or DID number	--	.50
O. Inter-Switch Voice Messaging (ISVM), <sup>3</sup> Each arrangement	2,000.00	3,000.00

<sup>1</sup> See Section 7, Custom Calling Services for monthly rates, and Section 3 of this Product Guide, Service Charges for nonrecurring charges.

<sup>2</sup> Non-recurring charges from Section 3 of this Product Guide may be applicable in addition to this rate.

<sup>3</sup> See Special Condition B.23.b.

Effective: April 1, 2016

---

EMPLOYEES SERVICES

TABLE OF CONTENTS

	<u>SHEET NO.</u>
I. APPLICABILITY	1
II. TERRITORY	1
III. RATES AND CHARGES	
A. Each Nonmanagement Employee's Residence Service	1
B. Each Management Employee's Residence Service	1
IV. SPECIAL CONDITIONS	1

Effective: April 1, 2016

---

EMPLOYEES SERVICES

I. APPLICABILITY

Applicable to residence telephone service provided to regular employees and retired employees of the Company receiving a pension under the Company's established pension plan.

II. TERRITORY

Within the exchange area of all exchanges as defined on maps as part of this Product Guide.

III. RATES AND CHARGES

A. Each Nonmanagement Employee's Residence Service

1. One local access line, including service connection and nonrecurring charges associated therewith, at 50% concession.
2. All other services, including usage, will be provided at regular filed rates.
3. Selected residence Custom Calling Services, offered from time to time and for periods of time to be determined at the Company's discretion, at 100% concession.

B. Each Management Employee's Residence Service except as provided in Special Condition 2

1. One local access line, including service connection and nonrecurring charges associated therewith, at 100% concession.
2. All other services including usage, will be provided at regular filed rates, except as provided for in Special Condition 2.
3. Selected residence Custom Calling Services, offered from time to time and for periods of time to be determined at the Company's discretion, at 100% concession.

IV. SPECIAL CONDITIONS

1. The preceding rate treatment does not apply to directory listings except as reflected in Special Condition 2.
2. The Company may provide primary service including supplemental service, directory listings, local and zone usage allowance and all required service connection and nonrecurring charges at 100% concession to management employees who are required to make regular use of their residence service line for business of the Company.
3. Under this schedule "regular employees" means those persons permanently employed by the Company on a full or part-time basis, including those persons on military leave of absence who were receiving "Employee's Service#" at the beginning of their official leave.
4. The rate treatment applicable to an employee's service prior to military leave may be extended by the Company during the period of military leave.
5. The rate treatment applicable to employees retired prior to June 1, 1968 will be extended to service of these employees following retirement whether or not they are receiving a pension from the Company.
6. Employees who retire after June 1, 1968 must be receiving a pension from the Company to be eligible for continuance of rate treatment under this schedule.



Effective: April 1, 2016

---

VIDEO CONNECTION SERVICE

TABLE OF CONTENTS

	<u>SHEET NO.</u>
I. APPLICABILITY	1
II. TERRITORY	1
III. ABBREVIATIONS	1
IV. GENERAL	
A. Definitions	1
B. Description	2
V. TERMS AND CONDITIONS	
A. Responsibility of the Company	7
B. Limitations/Availability	7
VI. APPLICATION OF RATES	
A. Rate Elements Apply to Video Connection Service	8
B. Video Digital Transport Access Line	10
C. Video Digital Transport Access Port	11
D. Video Digital Transport	12
E. Video Digital Transport Utilization	13
F. Video Digital Transport Premium Services	13
G. General Rate Terms and Conditions	14
VII. RATES AND CHARGES	
A. Video Transport Access Line	15
B. Video Digital Transport Access Port	16
C. Video Digital Transport	16
D. Video Digital Transport Utilization	17
E. Video Digital Transport Premium Services	17

Effective: April 1, 2016

---

VIDEO CONNECTION SERVICE

I. APPLICABILITY

This Product Guide contains the description, terms, conditions, and rates applicable to Video Connection Service furnished by the Company where facilities and conditions permit.

II. TERRITORY

Within all exchange areas as those areas are defined by maps as part of this Product Guide.

III. ABBREVIATIONS

ATM	-	Asynchronous Transfer Mode
COD	-	Video Coder Decoder
DCC	-	Digital Cross Connect
Kbps	-	Kilobits per second
Mbps	-	Megabits per second
MCU	-	Video Multipoint Control Unit
MRC	-	Monthly Recurring Charge
NRC	-	Nonrecurring Charge
NTSC	-	National Television Systems Committee
SPOT	-	Switched Point of Termination
SWC	-	Serving Wire Center
VCAL	-	Video Digital Transport Access Line

IV. GENERAL

A. Definitions

Asynchronous Transfer Mode (ATM) - A very high speed, cell based, switched, broadband transmission technology based on a fixed-length 53 byte cell.

Cell - The smallest unit of transport associated with the cell relay network. A cell is composed of 53 bytes.

Code - A piece of equipment for Coding and DECoding analog video signals to or from digital. The Code is the demarcation point between the Company's network and any customer premises equipment.

Kilocell - One thousand cells.

Gigacell - One billion cells.

Switched Point of Termination (SPOT) - The location at which the video session terminates (i.e. VCAL or Port), and as such may vary from session to session.

Video Multi Point Control Unit (MCU) - A piece of equipment that enables switching of video signals from site to site.

---

VIDEO CONNECTION SERVICE

IV. GENERAL (Continued)

B. Description

1. Video Connection Service is the movement, management, and control of moving pictures or video frames of information along with associated audio.
2. Video Connection Service is available in several transmission/ quality levels which correspond to varying customer requirements for video services. These are:

Broadcast Quality  
Commercial Quality  
Business Quality

(a) Broadcast Quality

Video Digital Transport Broadcast Quality service provides transmission capability which supports a picture quality that meets or exceeds performance requirements. Broadcast Quality transmits from one to four associated audio signals along with the video signal. Customers may select channel interface options to meet their specific requirements. Broadcast Quality may employ one of two types of network facilities to complete the customer circuit: Type I (analog) and Type II (digital).

- (1) Type I service uses high quality analog transmit and receive units, however, the lack of industry standards still requires that units on each end of the video path be compatible with each other's proprietary signaling algorithms. Type I service includes two audio channels with up to 15 KHz bandwidth.
- (2) Type II service uses high quality CODs with a digital interface of 44.736 Mbps to support NTSC baseband video along with up to four associated audio channels with 15 KHz bandwidth. Because there is no industry standard algorithm for digitally encoding Broadcast Quality Type II television signals, the COD must decode the proprietary algorithm used by the transmit COD.

(b) Commercial Quality

Video Digital Transport Commercial Quality service provides for transmission facilities which support a picture quality that is near the performance requirements of NTCS video but is not of as high a quality as Broadcast Quality video. A Commercial Quality service may employ one of two types of network facilities to complete the customer circuit: Type I (analog) and Type II (digital).

- (1) Type I service employs analog transmit and receive units along with analog network facilities to support the video signals and two associated audio channels with 12 KHz bandwidth.
- (2) Type II service employs high quality CODs with a digital interface of 44.736 Mbps and digital network facilities to support the video signals and up to four audio channels with up to 15 KHz bandwidth.

Because there are no industry standard algorithms for the transmission of analog or digitally encoded video signals, the CODs on each end of a video circuit must be compatible with each other's proprietary signaling protocol.

---

VIDEO CONNECTION SERVICE

IV. GENERAL (Continued)

B. Description (Continued)

2. Video Connection Service is available in several transmission/ quality levels which correspond to varying customer requirements for video services. (Continued)

(c) Business Quality

Video Digital Transport Business Quality service provides transmission facilities which utilize compressed video transmission techniques capable of transmitting good picture quality. A single audio channel with a frequency response to 7 KHz is provided with each video circuit. Business Quality video is suitable for teleconferencing between two geographically separate locations. Two types of Business Quality service are offered, Type I and Type II. Both types utilize digital facilities to provide two-way, two-point service.

(1) Type I service uses a transmission bandwidth of 384 Kbps which supports picture quality that is visually comparable to commercial quality video, but has less stringent technical parameters. Type I service has a noticeable motion impairment.

(2) Type II service uses a transmission bandwidth of 1.544 Mbps to support a picture quality that is visually comparable to commercial quality video, but has less stringent technical parameters.

3. Customer Provided Equipment

By subscription to a Video Digital Transport Access Thine (VCAL), the customer is provided with circuit equipment and outside plant facilities from the serving wire center (SWC) to the designated customer's location and a Code at the designated location. The customer must provide all customer premises equipment at each end of the network, such as cameras, monitors, audio and graphics equipment.

4. Rate Elements

- (a) The Video Connection Service is composed of the following basic rate elements:

Video Digital Transport Access Line (VCAL)  
Video Digital Transport Access Port  
Video Digital Transport  
Video Digital Transport Utilization  
Video Digital Transport Premium Services

Video Connection Service offers two different methods to reach the Video Digital Transport resources that provide transport, and in some cases, management and control of a video call. One, the Video Digital Transport Access Line (VCAL) includes video-enabling equipment along with circuit and outside plant facilities to access the customer's SWC. The other, Video Digital Transport Access Port does not include the video-enabling equipment as part of the network service.

- (b) Each Video Digital Transport interconnection between customer locations requires that at least one of the locations be served by a VCAL, to provide video transmission and/or reception and to allow the Company to monitor and meet the technical parameters of the service.

---

VIDEO CONNECTION SERVICE

IV. GENERAL (Continued)

B. Description (Continued)

4. Rate Elements (Continued)

- (c) Video Digital Transport includes transport and termination of the interoffice transmission of the customer's transmission Video Digital Transport signals. Applications include video transport between a customer's SWC and the associated Video Multipoint Control Unit (MCU) and video transport between SWCs.
- (d) Video Digital Transport Utilization includes high and low level video switching elements, video network control elements and trunking facilities. High and low level video switching elements refer to the use of Video Multipoint Control Units (MCU), Digital Cross Connect Units (DCC), or Asynchronous Transfer Mode (ATM) facilities. These switching facilities are included in the basic video network as required to meet the service requirements for Type II Broadcast and Commercial Quality Video Connection Services within the LATA
- (e) Video Digital Transport Premium Services are optional services that are not part of a basic video interconnection between customer locations. Video Digital Transport Premium Services currently include Quad Split and Still Frame. Quad Split allows one customer location to view the video transmissions from up to three other locations a multipoint connection on a single monitor over a single Video Digital Transport Access Line (VCAL). Still Frame provides for the transmission of a still frame (such as a graphics overhead) and the motion video image over a single VCAL.

5. Ordering Service

- (a) When Video Connection Service is ordered, the customer selects a VCAL or Port with consideration to the customer's specific video communications requirements. These requirements include, but are not limited to, the transmission parameters, the Video Digital Transport Premium Services that are available with that type of access line and whether or not the desired service is a fixed point-to-point service or a switched service.
- (b) Each form of Video Connection Service is a type of Video Connection Service. The identification of a type of service as Broadcast, Commercial or Business Quality is not intended to limit a customer's use of that of VCAL or Port and the associated utilization and/or transport. The type nomenclature is intended to provide general guidance as to the quality of video transmission and its typical use. So long as the components of Video Connection Service are utilized in the transmission, a customer can transmit any signals that the customer premises equipment (CPE) will support. For example, if the customer's CPE is capable of transmitting voice over a subscribed Video Connection Services there is no restriction against doing so provided that the components of the Video Connection Service are used in the transmission. The Company does not warrant such alternative uses of the service nor guarantee that changes will not be made in the service that may negate these uses.

---

VIDEO CONNECTION SERVICE

IV. GENERAL (Continued)

B. Description (Continued)

6. Service Elements

(a) Video Digital Transport Access Line (VCAL)

The Video Digital Transport Access Line (VCAL) rate applies for each customer designated location at which a VCAL is terminated. The charge will apply even if the customer designated location and the SWC are co-located in a Company building. The applicable VCAL rate is determined by the type of Video Connection Service that the customer orders and receives at the Customer's designated location. This VCAL rate provides for the Video Connection Service connection between the network demarcation point at the customer's premises and the Company's SWC. The Video Connection Service connection includes the appropriate video access line interface arrangement, circuit equipment and outside plant facilities. The standard video access line interface arrangement defines the technical characteristics associated with the type of facilities with which the video service will interconnect with at its Point of Termination (POT) and the type of signaling capability, if any. The VCAL includes any video encoding device that may be required to provide the service if any is required.

(b) Video Digital Transport Access Port

The Video Digital Transport Access Port rate applies for each Video Digital Transport Access Port provided by the Company for the use of the customer. The Video Digital Transport Access Port provides the customer with point of entry to the Company's switched video network in those instances where a Video Digital Transport Access Line cannot be provided. A Video Digital Transport Access Port may be located at any Video MCU. For example, a customer who has a customer designated location (CDL) outside of the LATA of service or not within a Company serving area within the LATA of service may use a Video

Video Digital Transport Access Port as a point of entry to the Company's switched video network. This would allow that CDL to make video connections with other customers who have Video Connection Service through the Company's switched video network in that LATA. The customer must obtain the appropriate video and/or private line transport from their CDL to the Company's Video Digital Transport Access Port and must present signals that are compatible with interface requirements of the VCALs to which they want to connect.

The Video Digital Transport Access Port includes a standard video access interface arrangement defining the technical characteristic associated with the type of facilities to which the video service is connected to and the type of signaling capability, if any. The Video Digital Transport Access Port does not include any video encoding devices but may include devices to control and monitor the video service.

(c) Video Digital Transport

The Video Digital Transport rate applies for video transport that may be required to provision Video Connection Service. The Video Digital Transport rate is specific to the type of Video Connection Service to which the customer subscribes.

In the case of an access line providing for point-to-point service, this rate applies for interoffice transport in those instances where the points of the point-to-point service are not served from the same SWC. In those instances where a point-to-point Video Connection Service has a CDL outside of the LATA or outside of the Company's serving area, this rate applies for transport from the Company's serving wire center (SWC) to a point of interconnection with non-Company facilities.

---

VIDEO CONNECTION SERVICE

IV. GENERAL (Continued)

B. Description (Continued)

6. Service Elements (Continued)

(c) Video Digital Transport (Continued)

The termination and transport rates applicable for point-to-point type video service that are not found in this schedule (as in the case of Business Quality Connect) must be ordered from the appropriate Private Line Product Guide. A customer using Business Quality Connect point-to-point services would order Video Digital Transport Access Lines from this schedule and appropriate Private Line Services for interoffice network transport and termination of their video signals.

In the case of access lines which are interconnected via the Company's switched video network, this rate will apply to interoffice transport from the SWC to the tending MCU in those instances when there is no MCU at the customer's SWC. Similarly this rate applies for transport from a point of interconnection with non-Company facilities to a Video Digital Transport Access Port.

(d) Video Digital Transport Utilization

The Video Digital Transport Utilization rate applies to Type II Broadcast and Commercial Quality Access Lines and Access Ports on a per access line or per port basis for usage of the Company's intraLATA interoffice switched video network. Video Digital Transport charges may apply in addition to these Utilization charges. In those instances where a video MCU is not located at the customer's SWC the Video Digital Transport rate will apply for the interoffice transport required to reach the Video MCU tending that SWC.

(e) Video Digital Transport Premium Services

The Video Digital Transport Premium Services, Quad Split and Still Frame, are optional services that are not part of a basic video interconnection between customer locations. The rate for these optional services applies to each access line for which they are ordered. Quad Split allows one customer location to view the video transmissions from up to three other locations of a multipoint connection on a single monitor over a single Video Digital Transport Access Line. Still Frame provides for the transmission of a still frame (such as a graphics overhead) and the motion video image over a single Video Digital Transport Access Line.

(f) Special Construction

Special Construction charges will apply in those instances where the customer orders Video Connection Service and suitable facilities are not available. If the customer orders video services not provided for in this schedule, Special Assembly rates and charges will apply.

Effective: April 1, 2016

---

VIDEO CONNECTION SERVICE

V. TERMS AND CONDITIONS

A. Responsibility of the Company

1. The Company's responsibility will be limited to the furnishing of Video Digital Transport facilities suitable for the Video Digital Transport Connection. The Company is not responsible for the installation, operation or maintenance of any equipment provided by the customer.
2. The Company reserves the right to temporarily interrupt Video Connection Service to maintain the video equipment. Maintenance will be performed during hours that will minimize the impact of disruptions to the customers. In addition, negotiated unscheduled or emergency situations may necessitate additional interruption time.

B. Limitations/Availability

1. Video Connection Service will only be offered where Company facilities and/or equipment permit. Special Construction charges may apply.
2. Video Connection Service is available only between customer locations within the same LATA. The customer may obtain appropriate private line or video services from an Interexchange Carrier to interconnect point-to-point Video Connection Services to video service locations not within the same LATA. Similarly, customers utilizing Type II Broadcast Quality Connect Services (Transceive) or Type II Commercial Quality Connect Services can obtain access to a locations outside of the Company's serving area or outside of the LATA by interconnecting such locations to Video Digital Transport Access Ports. Video Digital Transport is utilized between Ports and points of interconnection with non-Company facilities.
3. A Video Digital Transport Access Port can only be used to interconnect to a customer location that is not located in the Company's serving area (within the LATA) or that is outside of the LATA.
4. Video Digital Transport (interoffice) for Broadcast Quality Connect Type I and Commercial Quality Connect Type I is limited to a maximum of 25 airline miles.
5. The cable route distance between the customer's CDL and the Company's SWC cannot exceed 12,000 feet when Business Quality Connect Type I is utilized. This distance quality limitation does not apply to other types of VCALS.
6. The minimum service period is one year except as specified elsewhere within this Section.



Effective: April 1, 2016

---

VIDEO CONNECTION SERVICE

VI. APPLICATION OF RATES

A. The following rate elements apply to Video Connection Service:

1. Video Digital Transport Access Line (VCAL)

Broadcast Quality Connect

Type I

Transmit

Receive

Type II Transceive

Transmit Only

Receive Only

Transceive

Commercial Quality Connect

Type I

Transmit

Additional Transmit

Receive

Additional Receive

Type II Transceive

Business Quality Connect

Type I Transceive

Type II Transceive

2. Video Digital Transport Access Port

Broadcast Quality Connect

Type II

Commercial Quality Connect

Type II

Effective: April 1, 2016

---

VIDEO CONNECTION SERVICE

VI. APPLICATION OF RATES (Continued)

A. The following rate elements apply to Video Connection Service: (Continued)

3. Video Digital Transport

Broadcast Quality Connect  
Type I (Per Airline Mile)  
Type II (Per Airline Mile)

Commercial Quality Connect  
Type I (Per Airline Mile)  
Type II (Per Airline Mile)

Business Quality Connect  
Type I  
Transport (Fractional T-1 Transport)  
Termination (Fractional T-1 Termination)  
Type II  
Transport (DS-1 Transport)  
Termination (DS-1 Termination)

4. Video Digital Transport Utilization

Broadcast Quality Connect  
Type II  
Commercial Quality Connect  
Type II

5. Video Digital Transport Premium Services

Quad Split  
Still Frame

Effective: April 1, 2016

---

VIDEO CONNECTION SERVICE

VI. APPLICATION OF RATES (Continued)

B. Video Digital Transport Access Line

1. Broadcast Quality Connect Type I

The Type I Broadcast Quality Connect Video Digital Transport Access Line is a one way facility. The customer must order a Transmit access line in order to be able to transmit video signals over the Company's network facilities. Similarly the customer must order a Receive access line in order to be able to receive video signals over the Company's facilities. If the customer requires both transmit and receive capability at the premises then the customer must order both a Transmit access line and a Receive access line.

2. Broadcast Quality Connect Type II

The Type II Broadcast Quality Connect Video Digital Transport Access Line may be ordered as a transmit only, receive only or as bidirectional transceive facility. This type of access line may be ordered as a point-to-point service or in the case of the transceive facility it may alternatively be ordered as switched service. When Type II service is ordered as a switched service, the customer is provided with a facility capable of providing simultaneous transmission and reception of video signals to and from a switched point of termination (SPOT). The SPOT will be either another Type II Broadcast Quality Connect Video Digital Transport Access Line within the same LATA or a Video Digital Transport Access Port within the same LATA.

3. Commercial Quality Connect Type I

The Type I Commercial Quality Connect Video Digital Transport Access Line is a one way facility. The customer must order a Transmit access line in order to be able to transmit video signals over the Company's network facilities. Similarly, the customer must order a Receive access line in order to be able to receive video signals over the Company's facilities. If the customer requires both transmit and receive capability at the same premises then the customer must order both a Transmit access line and a Receive access line. The first Transmit or the first Receive access line that the customer orders for a customer designated location (CDL) will be provided at the "First System" rate. Subsequent Transmit or Receive access lines that the customer orders for the same CDL will be provided at the "Additional System" rate unless the total access lines (systems) should exceed sixteen. If the total number of access lines should exceed sixteen then seventeenth and every subsequent seventeenth access line will be rated as a "First System" with the others rated as "Additional Systems".

4. Commercial Quality Connect Type II

The Type II Commercial Quality Connect Video Digital Transport Access Line is a bidirectional (transceive) facility. This type of access line may be ordered as a point-to-point service or alternatively as switched service. The customer ordering this type of access line will be provided with a facility capable of providing simultaneous transmission and reception of video signals to and from a switched point of termination (SPOT). The SPOT will be either another Type II Commercial Quality Connect Video Digital Transport Access Line within the same LATA or a Video Digital Transport Access Port within the same LATA.

Effective: April 1, 2016

---

VIDEO CONNECTION SERVICE

VI. APPLICATION OF RATES (Continued)

B. Video Digital Transport Access Line (Continued)

5. Business Quality Connect Type I

The Type I Business Quality Connect Video Digital Transport Access Line is a bidirectional facility. The customer ordering this type of access line will be provided with a facility capable of providing simultaneous transmission and reception of video signals to and from another such access line or similar facility over Fractional T-1 Private Line facilities.

6. Business Quality Connect Type II

The Type II Business Quality Connect Video Digital Transport Access Line is a bidirectional facility. The customer ordering this type of access line will be provided with a facility capable of providing simultaneous transmission and reception of video signals to and from another such access line or similar facility over DS-1 Private Line facilities.

C. Video Digital Transport Access Port

1. Broadcast Quality Connect Type II

The Type II Broadcast Quality Connect Video Digital Transport Access Port is a bidirectional facility. A customer may only order this type of access to the Company's switched video transport facilities in order to terminate transport of compatible video signals from outside of the Company's serving area within the LATA or from outside of the LATA. This facility may not be ordered in lieu of a Video Digital Transport Access Line (VCAL) under circumstances where the Company has authority to provide a VCAL.

2. Commercial Quality Connect Type II

The Type II Commercial Quality Connect Video Digital Transport Access Port is a bidirectional facility. A customer may only order this type of access to the Company's switched video transport facilities in order to terminate transport of compatible video signals from outside of the Company's serving area within the LATA or from outside of the LATA. This facility may not be ordered in lieu of a Video Digital Transport Access Line (VCAL) under circumstances where the Company has authority to provide a VCAL.

Effective: April 1, 2016

---

VIDEO CONNECTION SERVICE

VI. APPLICATION OF RATES (Continued)

D. Video Digital Transport

1. Broadcast Quality Connect Type I

Type I Broadcast Quality Connect Transport provides for the transport and interoffice termination of signals originating from and/or terminating to Type I Broadcast Quality Connect VCALS. The monthly charge (MRC) for the Transport rate element is assessed on a per airline mile basis. Fractional parts of miles are rounded to the next higher mile before making the rate computation. The transport distance is limited to a maximum of 25 airline miles.

2. Broadcast Quality Connect Type II

Type II Broadcast Quality Connect Transport provides for the transport and interoffice termination of signals originating from and/or terminating to Type II Broadcast Quality Connect VCALS or Access Ports. The monthly charge (MRC) for the Transport rate element is assessed on a per airline mile basis. Fractional parts of miles are rounded to the next higher mile before making the rate computation.

3. Commercial Quality Connect Type I

Type I Commercial Quality Connect Transport provides for the transport and interoffice termination of signals originating from and/or terminating to Type I Commercial Quality Connect VCALS. The monthly charge (MRC) for the Transport rate element is assessed on a per airline mile basis. Fractional parts of miles are rounded to the next higher mile before making the rate computation. The transport distance is limited to a maximum of 25 airline miles.

4. Commercial Quality Connect Type II

Type II Commercial Quality Connect Transport provides for the transport and interoffice termination of signals originating from and terminating to Type II Commercial Quality Connect Video Digital Transport Access Lines (VCALS) or Access Ports. The monthly charge (MRC) for the Transport rate element is assessed on a per airline mile basis. Fractional parts of miles are rounded to the next higher mile before making the rate computation.

5. Business Quality Connect Type I

Type I Business Quality Connect Transport provides for the transport and interoffice termination of signals originating from and terminating to Type I Business Quality Connect VCALS. Type I Business Quality Connect Transport is provided by Fractional T-1 Service which is provided from the Facilities for Intrastate Access Tariff C-1.

6. Business Quality Connect Type II

Type II Business Quality Connect Transport provides for the transport and interoffice termination of signals originating from or terminating to Type II Business Quality Connect VCALS. Type II Business Quality Connect Transport is provided by DS-1 Service which is provided from the Facilities for Intrastate Access Tariff C-1.

Effective: April 1, 2016

---

VIDEO CONNECTION SERVICE

VI. APPLICATION OF RATES (Continued)

E. Video Digital Transport Utilization

1. Broadcast Quality Connect Type II

Type II Broadcast Quality Connect Utilization provides for the switching and interoffice trunking of signals originating from and terminating to Type II Broadcast Quality Connect VCALs or Access Ports utilizing the Company's switched video network. The Video Digital Transport Utilization MRC is applied each month to the gigacells of network utilization that result from the customer's connect time during each monthly billing period. The accumulated usage in gigacells is rounded to the nearest one thousandth of a gigacell (kilocell) prior to the application of the rate.<sup>1</sup>

2. Commercial Quality Connect Type II

Type II Commercial Quality Connect Utilization provides for the switching and interoffice trunking of signals originating from and terminating to Type II Commercial Quality Connect VCALs or Access Ports utilizing the Company's switched video network. The Video Digital Transport Utilization MRC is applied each month to the gigacells of network utilization that result from the customer's connect time during each monthly billing period. The accumulated usage in gigacells is rounded to the nearest one thousandth of a gigacell prior to the application of the rate.<sup>1</sup>

F. Video Digital Transport Premium Services

1. Quad Split

Quad Split is an optional enhancement to Type II Commercial Quality Connect Video Connection Service (Transceive) when it is provided as a switched service. The Quad Split MRC is applied each month to the gigacells of network utilization that result from the customer's connect time with the Quad Split feature during each monthly billing period. The accumulated usage in gigacells is rounded to the nearest one thousandth of a gigacell (kilocell) prior to the application of the rate. This rate applies in addition to the regular VCAL or Port rate, the Utilization rate and the Transport (if required) rate.<sup>1</sup>

2. Still Frame

Still Frame is an optional enhancement to standard Business Quality Connect Type I and Type II Services. The Still Frame rate is applied on a per Video Digital Transport Access Line (VCAL) basis. This rate applies in addition to the regular VCAL rate.

<sup>1</sup> Until the Company's network and billing system become capable of measuring and billing gigacell usage, the customer's Utilization will be assessed an assumed usage of 36.91 gigacells per month for each VCAL or Access Port.

---

VIDEO CONNECTION SERVICE

VI. APPLICATION OF RATES (Continued)

G. General Rate Terms and Conditions

1. Moves

When a customer requests a move or relocation of a VCAL or Access Port and/or a rearrangement of the Transport associated with the VCAL or Access Port, this move, relocation and/or rearrangement will be treated as a termination of the existing VCAL or Access Port service and the establishment of a new service for the application of all charges.

2. Cancellation or Change in Application for Service

When an application for service is cancelled or changed in whole or in part:

After the completion of installation, but prior to the establishment of service, the customer is required to pay the nonrecurring and minimum charges which would apply if the service has been established.

Prior to the completion of installation, the customer may be required to pay the costs incurred by the Company but not exceeding the amount that would be charged above.

3. Custom Payment Plans

At the request of a customer the Company may, at its option, offer a Custom Payment Plan that provides a payment schedule with a net present value equal to the net present value of the Nonrecurring Charges (NRCs) and Monthly Recurring Charges (MRCs) that would otherwise be payable under the contract period selected. The net present value computations shall be made utilizing the Company's Authorized Rate of Return. The nonrecurring Charge associated with a Custom Payment Plan may never be less than twenty-five percent (25%) of the nonrecurring charge. Custom Payment Plan methodology may be used to provide a Custom Payment Plan with a nonrecurring charge and a zero MRC. In any instance, the Custom Payment Plan provides only for service during the specified contract period and does not give the customer ownership of or equity in the facilities that the Company provides in the provision of the service(s).

4. Expiration of Contract Period

If the customer's contract period expires and the customer has not cancelled his service or established a new contract with the Company, the customer's service shall be continued under a month-to-month contract at the monthly rate(s) specified in the Product Guide for the contract term that just expired. This procedure will continue the customer's service with no change in monthly contract rates except in those instances when the expired contract was under a Custom Payment Plan.

When one contract period ends and a new one begins, the customer begins paying the MRC for the new contract period. The nonrecurring charge is not accessed again unless the customer has required the Company to change the service in some way or unless service has been discontinued between the expiration of the old contract and the initiation of the new contract.

Effective: April 1, 2016

VIDEO CONNECTION SERVICE

VII. RATES AND CHARGES

The following rates and charges apply for Video Connection Service.

	<u>Nonrecurring Charge</u>	<u>1 Year MRC</u>	<u>3 Year MRC</u>	<u>5 Year MRC</u>	<u>7 Year MRC</u>
A. Video Digital Transport Access Line Access Line					
Broadcast Quality Connect					
Type I					
Transmit	\$1,300.00	\$1,280.00	\$1,180.00	\$1,060.00	\$ 940.00
Receive	1,300.00	1,280.00	1,180.00	1,060.00	940.00
Type II					
Transmit Only	1,300.00	1,670.00	1,600.00	1,550.00	1,400.00
Receive Only	1,300.00	1,670.00	1,600.00	1,550.00	1,400.00
Transceive	2,500.00	2,400.00	2,300.00	2,200.00	2,100.00
Commercial Quality Connect					
Type I (per system)					
Transmit - 1st	900.00	1,150.00	1,070.00	1,000.00	900.00
Transmit - Addnl	400.00	560.00	525.00	500.00	440.00
Receive - 1st	900.00	1,150.00	1,070.00	1,000.00	900.00
Receive - Addnl	400.00	560.00	525.00	500.00	440.00
Type II					
Transceive	1,800.00	2,060.00	1,940.00	1,800.00	1,600.00
Business Quality Connect					
Type I Transceive	2,800.00	1,630.00	1,550.00	1,450.00	1,270.00
Type II Transceive	2,800.00	1,810.00	1,660.00	1,510.00	1,350.00



Effective: April 1, 2016

VIDEO CONNECTION SERVICE

VII. RATES AND CHARGES (Continued)

	<u>Nonrecurring Charge</u>	<u>1 Year MRC</u>	<u>3 Year MRC</u>	<u>5 Year MRC</u>	<u>7 Year MRC</u>
B. Video Digital Transport Access Port					
Broadcast Quality Connect Type II	\$ 100.00	\$ 100.00	\$ 100.00	\$ 100.00	\$ 100.00
Commercial Quality Connect Type II	100.00	100.00	100.00	100.00	100.00
C. Video Digital Transport					
Broadcast Quality Connect Type I (Per Mile)	None	37.50	37.50	37.50	37.50
Type II (Per Mile)	None	55.75	55.75	55.75	55.75
Commercial Quality Connect Type I (Per Mile)	None	37.50	37.50	37.50	37.50
Type II	None	55.75	55.75	55.75	55.75
Business Quality Connect Type I <sup>1</sup>					
Type II <sup>2</sup>					

<sup>1</sup> See the Facilities for Intrastate Access Tariff C-1, Fractional T-1 Services.

<sup>2</sup> See the Facilities for Intrastate Access Tariff C-1, Private Line Services for DS-1, High Capacity Services.

Effective: April 1, 2016

VIDEO CONNECTION SERVICE

VII. RATES AND CHARGES (Continued)

	<u>Nonrecurring Charge</u>	<u>1 Year MRC</u>	<u>3 Year MRC</u>	<u>5 Year MRC</u>	<u>7 Year MRC</u>
D. Video Digital Transport Utilization					
Broadcast Quality Connect					
Type II (Per Gigacell)	\$ None	\$ 20.50	\$ 20.50	\$ 20.50	\$ 20.50
Commercial Quality Connect					
Type II (Per Gigacell)	None	20.50	20.50	20.50	20.50
E. Video Digital Transport Premium Services					
Quad Split <sup>1</sup>					
(Per Gigacell)	None	40.00	40.00	40.00	40.00
Still Frame					
Business Quality					
Type I	150.00	275.00	275.00	275.00	275.00
Type II	150.00	275.00	275.00	275.00	275.00

<sup>1</sup> Commercial Type II Transceive - Switched Service only.

Effective: April 1, 2016

---

RADIO TELEPHONE SERVICE

TABLE OF CONTENTS

SHEET NO.

SERVICE THROUGH RADIO TELEPHONE UTILITIES

I. Applicability	1
II. Special Conditions	1

MARITIME RADIO TELEPHONE SERVICE

I. Applicability	2
II. Territory	2
III. Special Conditions	2
IV. Rates and Charges	3

Effective: April 1, 2016

---

RADIO TELEPHONE SERVICE

SERVICE THROUGH RADIO TELEPHONE UTILITIES

I. APPLICABILITY

Applicable to service through Radio Telephone Utilities located within the indicated exchange areas as these exchanges are defined on maps as part of the General Exchange Tariff, Schedule AB, furnished or made available by the Company by connection with mobile radio facilities of the following companies:

<u>Name</u>	<u>Territory</u>
Chalfont Communications Palm Desert and Palm Springs Exchanges	Banning-Beaumont
Radio Dispatch Corp.	Pomona and Ontario Exchanges
Radiocall Corporation	Redondo Exchange
Valley Mobile Communications Inc.	Lancaster Exchange

II. SPECIAL CONDITIONS

1. The Company's portion of service between mobile stations of a Radio Telephone Utility and stations outside the local service area(as defined in Section 5 of this Product Guide) of the Company's serving exchange is furnished from the point of connection at rates and special conditions set forth in Section 28 of this Product Guide, Message Toll Telephone Service.

Effective: April 1, 2016

---

RADIO TELEPHONE SERVICE

MARITIME RADIO TELEPHONE SERVICE

I. APPLICABILITY

Applicable to Maritime Radio Telephone Service made available to ships equipped for this service when within the service area of this VHF coastal station through which such service is furnished.

II. TERRITORY

VHF maritime coastal station service area consists of the principal exchange listed below, any extended local service area of the exchange as specified in Section 5 of this Product Guide and that area extending seaward and within the service area as defined on the map as part of this Product Guide.

A. Principle exchanges of the VHF maritime coastal stations:

Los Gatos  
Santa Barbara

III. SPECIAL CONDITIONS

1. VHF Maritime Service is a communication service through a coastal station between a wire line or mobile telephone and a ship station or between two ship stations.

VHF Maritime Service is furnished between a coastal station and

- a. A ship station in range of the coastal station, to provide a portion of facilities for telecommunication with other telephones, or
  - b. Two ship stations in range of the coastal station, to provide facilities for telecommunication between such ship stations.
2. VHF Maritime Service is available to ship equipped for this service when in range of a coastal station through which such service is furnished and subject to transmission, atmospheric, and like limitations.
  3. Where the message is between two ships served through the coastal station, the Rate in A.1. following will be applied to each ship.
  4. No additional charge applies to ship originated calls to any telephone located within the service area as defined under territory.
  5. For service with ships of foreign registry served through coastal stations, in addition to the charge specified in this Product Guide, the ships station charge specified in the List of Ship Stations, published by the International Telecommunication Convention of Geneva (1959) shall apply.

Effective: April 1, 2016

---

RADIO TELEPHONE SERVICE

MARITIME RADIO TELEPHONE SERVICE (Continued)

IV. RATES AND CHARGES

A. VHF Maritime Service

1. The station charge to each ship on the connection which is served through the maritime coastal station is:

- |   |        |
|---|--------|
| a. For the initial period of three minutes<br>or fraction thereof | \$2.55 |
| b. For each additional minute of fraction<br>thereof              | .85    |

2. Message outside of the coastal station service area

Regular filed operator station-to-station or person-to-person message toll rates apply in addition to the station charge in A.1. above.

Effective: April 1, 2016

---

N11 DIALING SERVICE

TABLE OF CONTENTS

	<u>SHEET NO.</u>
I. DESCRIPTION	1
II. DEFINITIONS	1
III. TERMS AND CONDITIONS	2
A. General	2
B. Customer Responsibility	2
C. Liability	2
IV. APPLICABILITY	3
V. RATES AND CHARGES	5

Effective: April 1, 2016

---

## N11 DIALING SERVICE

### I. DESCRIPTION

N11 refers to a nationally assigned three digit abbreviated dialing code. The Federal Communications Commission (FCC) has ordered that certain N11 numbers be assigned for national purposes and specific uses. The following abbreviated dialing codes, the uses for the code and classification of Customer permitted to use such numbers and purchase the Company's N11 Dialing Service(s) are listed below:

211 - Access to non-emergency community information and referral services. This code is only assignable to authorized community and social service providers of information and referrals.

311 - Access to non-emergency state or local government services. This code is only assignable to local or state government agencies.

511 - Access to travel information services. This code is only assignable to federal, state or local government transportation agencies.

N11 Dialing Service ("Service") is optional, intraLATA, local voice grade exchange communications service that allows Company's telephone exchange end-user subscribers or other calling parties that have local exchange service from Company's central office switched dial tone, to reach the N11 Customer by dialing an abbreviated telephone number. (This includes end-user subscribers of Company's local exchange service as well as calling parties served by Company's local exchange services resold by other local exchange service providers.)

### II. DEFINITIONS

Company - Frontier California Inc. (Frontier)

Customer or N11 Customer - For purposes of Company's N11 Dialing Service, Customer (also "N11 Customer") is the entity authorized by law and relevant governmental agency action to purchase the N11 Dialing Service for the permitted governmental purpose(s) described above. Customer may not resell the N11 Dialing Service nor use it for any commercial purpose.

Customer Call Center - A N11 Customer location where N11 Calls are to be routed and answered.

End-User - A Company subscriber of local exchange service.

Routing Telephone Number - A valid seven or ten digit telephone number within the Public Switched Telephone Network used to route and terminate an N11 abbreviated dialing code to the N11 Customer call center.



Effective: April 1, 2016

---

N11 DIALING SERVICE

III. TERMS AND CONDITIONS

A. General

1. N11 Dialing Service is an optional Service provided on a month to month basis. A minimum service period of one month applies for this Service.
2. N11 Dialing Service is provided solely for the benefit of the N11 Customer. Company's provision of such Service shall not be interpreted, construed or regarded, directly or indirectly, as being for the benefit of or creating any obligation toward, or any right of action on behalf of, any third person or other legal entity.
3. The Company will make every effort to route N11 calls to the appropriate N11 Customer call center, however, Company will not be held responsible for routing mistakes or errors.
4. The provisioning of N11 Dialing Service does not include the inspection or constant monitoring of facilities to discover Service errors, defects, and malfunctions, nor does the Company undertake such responsibility. The N11 Customer shall make such operational tests as, in the judgment of the N11 Customer, are required to determine whether the Company's facilities are functioning properly for Customer's use. The N11 Customer shall promptly notify the Company in the event the Company's facilities are not functioning properly.

B. Customer Responsibility

1. The N11 Dialing Service Customer is responsible for obtaining all necessary permissions, licenses, written consents, waivers and releases and all other rights from all persons or entities whose information, work or services are used in connection with the Service.
2. The N11 Customer shall comply with applicable FCC orders, rules and regulations pertaining to the N11 Dialing Service.
3. The N11 Customer will subscribe to adequate telephone facilities, both initially and subsequently as required in the judgment of the Company, to handle calls to the N11 Customer without impairing the Company's general telephone service or telephone plant.

C. Liability

In addition to the Limitation of Liability as set out in the Product Guide, the following additional provisions apply to N11 Dialing Service:

1. The Company has no liability for claims, losses or damages of any kind under any theory, including but not limited to, personal injury or damage to real or tangible personal property, attributable to or caused by the acts or omissions of the N11 Customer or any third party.
2. The Company has no liability for claims of any kind, including claims for bodily injury or damage to real or tangible personal property, by end-users.
3. Claims by an end-user, who is a business subscriber of Company's local exchange service, directly related to the local exchange service provided by Company to the end-user shall be governed by the Section 2, General Terms and Conditions, of this Product Guide.
4. Claims by an end-user, who is a residential subscriber of Company's local exchange service, directly related to the local exchange service provided by Company to the subscriber/end-user shall be governed by the Company's Intrastate General Exchange Tariff, Schedule D & R.

Effective: April 1, 2016

---

N11 DIALING SERVICE

IV. APPLICABILITY

1. The Company can only make the N11 number code available to end-users located in Company local telephone service exchanges. To establish access to the N11 number code for use by end-users in non-Company local exchanges, the N11 Customer must make appropriate arrangements with the local exchange service provider companies serving those local exchanges. The N11 Customer must also independently make arrangements with wireless and voice over internet protocol service providers in order for the N11 number code to function within the networks of such service providers.
2. The N11 Customer shall make written application to Company for the N11 Dialing Service desired specifying which Company local exchange(s) are to be routed to the N11 Customer's call center and confirming their eligibility as a N11 Customer. The N11 Customer is also responsible for informing Company and all other relevant service providers that the N11 Customer has established an N11 call center in the designated area.
3. Only calls originating within an operational N11 Dialing service area will be routed to a N11 Customer's call center. End-users dialing the relevant N11 number code outside an operational N11 Dialing Service area will receive a recorded message that the call cannot be completed as dialed.
4. There can be only one N11 Customer (one for each type of abbreviated dialing code set out above) in each designated geographic area. N11 Dialing Service areas may not overlap. As requests are submitted by qualifying entities for N11 number assignment for use with Company's N11 Dialing Service, the Company will provide such Services on a first come, first service basis.
5. N11 Dialing Service will not provide calling number information in real time to the N11 Customer. If the N11 Customer needs this type of information, the N11 Customer must separately subscribe to a compatible Calling Number Identification service. Company is not liable for any claims based on incorrect or unavailable calling number information.
6. End-user N11 calls are not permitted where local calling is restricted (e.g. prisons).
7. The N11 Customer may designate only one RTN per N11 Dialing Service area but may designate different RTNs for different N11 Dialing Service areas as described below.
  - If the N11 Customer utilizes more than one N11 RTN, it must designate the specific serving office or NPA-NXX to be served by each RTN.
  - The Company will route N11 calls originating from an end-user on Company's local exchange network whether the end-user purchases local exchange service directly from the Company or from another local exchange service provider who provides services to the end-user by utilizing Company's local exchange dial tone service.
  - All RTNs shall be local in nature and shall not result in intraLATA toll, interLATA long distance or pay-per-call charges to Company end-users. Where the N11 Customer's call center is not located within the Company's relevant local exchange service area, then the N11 Customer shall separately establish Foreign Exchange Service, Remote Call Forwarding Service or supply the Company with a toll free telephone number so that Company end-user calls to the Customer's N11 Dialing Code remain local in nature.

Effective: April 1, 2016

---

N11 DIALING SERVICE

IV. APPLICABILITY (Continued)

8. If the Company, for any reason, can not route N11 calls from the calling party's NPA-NXX, the Company will default route the call based on the caller's serving Central Office.
9. Local measured or message rate service charges will apply for Company end-users, subscribing to measured or message rate service, for calls such end-users place to an N11 number
10. The Company will route N11 calls based on its relevant central office. If a central office services one or more exchanges areas or multiple states, the Company will route the N11 call based on the originating NPA-NXX. The Company is not responsible or liable in any way for claims arising due to physical N11 call routing boundaries not matching the boundaries of end-user or N11 caller's requested service area.
11. A calling party dialing N11 from a Company payphone served by one of the offices in the N11 Dialing Service calling area may be charged for such calls. Such charges to calling parties are separate and apart for charges covered under this service.
12. N11 Dialing Service provided pursuant to individual case basis contracts
  - References to "Tariff" or "tariff" in such existing contracts shall be replaced with, and shall now mean this "Product Guide" including but not limited to the portion of the Product Guide for N11 Dialing Service.
  - N11 Dialing Service provided pursuant to in-service, currently effective individual case basis contracts, shall continue until such contracts expire or are terminated pursuant to the specific terms of the applicable contract. Existing N11 Customers wanting to continue service would purchase N11 Dialing Service pursuant to the rates, terms and conditions of this Product Guide using Company's established ordering procedures.

Effective: April 1, 2016

---

N11 DIALING SERVICE

V. RATES AND CHARGES

The following rates are applicable for only the N11 number codes identified in this N11 Dialing Service section of the Product Guide.

	<u>Nonrecurring Charge</u>	<u>Monthly Rate</u>
Service Establishment Charge, per N11 Service Configuration, per Customer	\$1,700.00	-0-
N11 System Configuration per N11 Code, per Customer	-0-	\$ 60.00
Initial Programming Charge per Company Central Office	150.00	-0-
Subsequent changes to Routing Telephone Number (RTN) per each RTN, per occurrence	25.00	-0-

The rates above are in addition to charges for other applicable services required for transporting and terminating messages at the N11 Customer's Call Center (e.g., Dial Tone lines, PBX trunks, Centrex services lines, Foreign Exchange service, 800 number types' service, etc.).

N11 Customers continuing N11 Dialing Service pursuant to this Product Guide, after the expiration of their individual case basis contract, shall not be subject any nonrecurring charges provided there are no changes required to conform to N11 Dialing Services, or lapse in, the continuing Service. If changes are required, all applicable non recurring charges shall apply.

Effective: April 1, 2016

---

CUSTOM ROUTING SERVICE <sup>1</sup>

TABLE OF CONTENTS

	<u>SHEET NO.</u>
I. APPLICABILITY	1
II. TERRITORY	1
III. GENERAL	1
IV. DEFINITION OF TERMS	1
V. DESCRIPTION OF FEATURES	2
VI. DESCRIPTION OF SERVICE	3
VII. SPECIAL CONDITIONS	4
VIII. APPLICATION OF RATES AND CHARGES	4
IX. RATES AND CHARGES	
A. Group Redirect	6
B. Flexible Call Forwarding	8

<sup>1</sup> Effective December 15, 2005, Custom Routing Service is grandfathered and limited to existing customers at existing locations. No moves, changes or additions to existing service will be permitted.

Effective: April 1, 2016

---

CUSTOM ROUTING SERVICE<sup>1</sup>

I. APPLICABILITY

This Product Guide contains the description, terms, conditions, and rates applicable to Custom Routing Service furnished by the Company where facilities and conditions permit.

II. TERRITORY

Within all exchange areas as those areas are defined by maps as part of this Product Guide.

III. GENERAL

Custom Routing Service (CRS) is an optional network service that enables the subscribing customer to redirect all or a portion of incoming voice and data calls to other telephone numbers of the customer's choice. CRS offers options to automatically bulk transfer groups of lines to another location or multiple locations as well as redirect calls on an individual line basis. Customers may define up to three configurations for the purpose of customizing their network.

Customers may reroute calls by using local, intraLATA or interLATA facilities. Utilizing Advanced Intelligent Network (AIN) Service and Service Control Point (SCP) capabilities to provide the rerouting functions, Custom Routing Service is available only where Company facilities and conditions permit.

IV. DEFINITION OF TERMS

**Advanced Intelligent Network (AIN)** - AIN is a telecommunications network designed with intelligence located in computer nodes called Service Control Points (SCPs). SCPs are distributed throughout the network and allow for rapid service creation and deployment.

**Group** - A set of customer telephone numbers that are redirected in the same manner. For example: when redirection of incoming calls is required, all telephone numbers within a "group" will be redirected at the same time and to the same option. However, the actual individual telephone numbers within the group may be directed to different destinations. There is no maximum number of telephone numbers in a group; however, the maximum number of groups allowed to a customer is fifty.

**Main Number** - The customer's directory number that has Custom Routing Service. The customer determines routing information based on this number.

**Service Control Point (SCP)** - The Service Control Point (SCP) is a component of an intelligent network that stores customer data and service logic.

**Supergroup** - The combining of two or more groups for the purpose of redirecting calls of more than one group in a single transaction. This allows the customer to activate Customer Routing Service for the entire Supergroup rather than for each group individually.

**Type I Lines** - Individual exchange access lines, Centrex Station Line and Direct-Inward-Dial (DID) numbers (other than the main DID number) that are either an individual line or in a two-line hunt group.

**Type II Lines** - PBX trunks (DID and non-DID Systems), DID main numbers and associated terminals, and both exchange access lines and Centrex Station Lines terminating in hunting arrangements of three or more lines.

<sup>1</sup> Effective December 15, 2005, Custom Routing Service is grandfathered and limited to existing customers at existing locations. No moves, changes or additions to existing service will be permitted.

---

CUSTOM ROUTING SERVICE <sup>1</sup>

V. DESCRIPTION OF FEATURES

**Basic Redirect** - Basic Redirect is a feature offered under Group Redirect Service. It allows the customer to redirect incoming calls to as many as three sets of telephone numbers. Basic Redirect can be used in one, two or all three customer defined configurations. There is no additional charge for Basic Redirect. However, Incoming Number Identification, Percentage Redirecting, and/or Time-of-Day/Day-of-Week Redirection can be purchased for an additional charge in lieu of Basic Redirect.

**Incoming Number Identification Redirection** - An optional Group Redirect feature that allows the customer to redirect an incoming call based upon the originating telephone number, NPA-NXX, or NPA of the incoming caller. If the incoming caller's number is on a predesignated list, the call will be redirected to a preselected telephone number. If the incoming caller's number is not on the list, the call will be completed as dialed or routed to a default number (selected by the customer).

The customer may have as many telephone numbers as desired on the list. The customer will be billed for each 100 numbers or any fraction thereof. Incoming Number Identification Redirection may be used in one, two or all three customer defined configurations.

Incoming Number Identification Redirection may NOT be used to pass the calling party's number to the customer.

**Percentage Redirecting** - This optional Group Redirect feature allows the customer to redirect incoming calls based on percentages. The customer may choose up to five different percentages but all percentages must total 100 percent. For example: 33 percent of incoming calls may be redirected to one destination, 33 percent to another and the remaining 34 percent may be redirected to still another destination. This feature may be used in one, two or all three customer defined configurations and an optional feature charge will be incurred for each configuration selected.

**Time-of-Day/Day-of-Week Redirection** - This optional feature allows the customer to redirect incoming calls to another location at predesignated times of the day and/or different days of the week. The system will automatically route calls until the customer changes the specifications. This option may be used in one, two or all three customer defined configurations when selected for Group Redirect; it may be used in both customer defined configurations when selected with Flexible Call Forwarding. A charge is incurred for each time the customer chooses this option for a customer defined configuration.

<sup>1</sup> Effective December 15, 2005, Custom Routing Service is grandfathered and limited to existing customers at existing locations. No moves, changes or additions to existing service will be permitted.

Effective: April 1, 2016

---

CUSTOM ROUTING SERVICE<sup>1</sup>

VI. DESCRIPTION OF SERVICE

Custom Routing Service consists of two main options, Group Redirect and Flexible Call Forwarding.

**Group Redirect** - An option which allows the customer to create groups of directory telephone numbers and control whether the incoming calls made to members of the group will arrive as dialed or be redirected elsewhere. The customer has a choice of up to three different routing configurations for each group of directory numbers. Each routing option chooses an alternate destination based on one or up to three of the following routing features:

- Basic Redirect
- Incoming Number Identification
- Percentage Distribution
- Time-of-Day/Day-of-Week

Each member of a group can have up to five different redirect destinations (telephone numbers) for each of the three possible routing options. Group Redirect is available with both Type I and Type II lines.

**Flexible Call Forwarding** - An option which allows a customer's individual line the capability to separately forward calls to another telephone number. The user can activate Flexible Call Forwarding from a remote location if desired. The following call forwarding choices are available:

- to a default destination. The default destination is assigned at the time the customer orders this service. Changes in the assigned destination must be performed by the Company and service charges from Section 3 of this Product Guide will apply.
- to an override destination. This feature is controlled by the customer after the Customer Routing Service system has been established. When flexible call forwarding has been activated and the destination has been entered, this feature overrides the default destination.
- Either of two predefined forwarding schedules which can determine the destination according to Day-of-Week /Time-of-Day.

If a line/station has the Flexible Call Forwarding option and is also a member of a Group Redirect group, the Flexible Call Forwarding option takes precedence when both options are activated. Flexible Call Forwarding is available with Type I Service only.

**Service Activation** - The customer activates Custom Routing Service (CRS) by dialing into the Company network controller using a touchtone telephone. Upon reaching the network controller, the customer must enter a personal identification number (PIN) to access the system.

After entering the system, the customer may redirect calls for the desired group(s). A group may be a floor, department, building, or even the whole organization. A supergroup can be pre-assigned and used to redirect calls for two or more groups. These groups (Supergroup or Group) must be preassigned upon establishment of the service.

The customer may call into the system as frequently as required to control incoming calls.

<sup>1</sup> Effective December 15, 2005, Custom Routing Service is grandfathered and limited to existing customers at existing locations. No moves, changes or additions to existing service will be permitted.



Effective: April 1, 2016

---

CUSTOM ROUTING SERVICE<sup>1</sup>

VII. SPECIAL CONDITIONS

1. Custom Routing Service (CRS) is available where Company facilities and conditions permit.
2. Customer must have touchtone capability.
3. Group Redirect Type I must be purchased for a minimum of five (5) lines. Group Redirect Basic Type II must be purchased for a minimum of one (1) trunk. There is no maximum number of lines or trunks that the customer must have for subscription to CRS.
4. The Type I or Type II charges apply for each line having the capability of completing a call.
5. Each group may have a maximum of three redirect customer defined configurations.
6. Flexible Call Forwarding may only be ordered for Type I lines.
7. The minimum service period for CRS is 6 months.
8. See Section 2 of this Product Guide for termination liability terms and conditions.
9. If calls are redirected to an IntraLATA long distance number or to an InterLATA carrier, long distance charges apply to each call redirected beyond the local calling area of the main number.

VIII. APPLICATION OF RATES AND CHARGES

Message Charges

When calls are redirected outside of the local calling area of an exchange, the applicable local measured usage rates for measured calls and/or toll charges will apply in addition to the rates for Custom Routing Service.

Service Establishment Charge

The Service Establishment Charge will apply only for the initial order for Basic Custom Routing Service (CRS), in addition to the applicable nonrecurring charges in Section 3 of this Product Guide. Other nonrecurring charges associated with other options (such as, Time-of-Day/Day-of-Week, Percentage Redirecting, etc.) are in addition to the Service Establishment Charge.

Unless the customer cancels service and reestablishes CRS at a later date, the service charge will not apply again for the same customer.

When CRS is ordered for both Type I and Type II services at the same time, the Service Establishment Charge will only apply once and the higher charge will apply. This is also applicable when two Type I services are ordered at the same time.

<sup>1</sup> Effective December 15, 2005, Custom Routing Service is grandfathered and limited to existing customers at existing locations. No moves, changes or additions to existing service will be permitted.

Effective: April 1, 2016

---

CUSTOM ROUTING SERVICE<sup>1</sup>

VIII. APPLICATION OF RATES AND CHARGES (Continued)

Monthly Rates

The monthly rates per line are determined on the total number of lines or trunks equipped with Custom Routing Service (CRS). For example: a customer with 350 lines with CRS is billed for all 350 lines at the monthly rate for 101-500 lines. Later if the same customer adds 200 lines, the monthly rate for 501-1000 lines will be applied to the new total of 550 lines. The monthly rate per line will be based on the number of telephone numbers with CRS. In addition to the monthly rate, a nonrecurring charge will apply to each number installed.

A nonrecurring charge applicable to each CRS rearrangement performed by the Company. Rearrangements include changing the telephone number to which a line is redirected, moving a line/trunk from one Group to another Group, and the addition of a line/trunk. Rearrangement charges are in addition to applicable nonrecurring charges in Section 3 of this Product Guide. Rearrangement charges include a per system charge and an incremental charge based on the number of lines in the system rearranged

Personal Identification Number (PIN) Change

This charge applies each time the customer requests the Company to change the PIN after the initial service establishment. A service order will be generated after the initialization takes place and a PIN change charge will apply. This charge is applicable to both Group Redirect and Flexible Call Forwarding.

Group Charges

There will be no additional charges for the first group ordered. A nonrecurring charge will apply to each additional group.

Optional Features

Incoming Number Identification Redirection

A monthly charge and a nonrecurring charge will apply to each 100 telephone numbers, or fraction thereof, listed for Incoming Number Identification Redirection which can be used in one, two, or all three customer defined configurations. For changes made by the Company on behalf of the customer, rearrangement charges will apply. The monthly rate is based on the number of options in which the feature is used. This optional feature is available for Group Redirect only.

Percentage Redirecting

A nonrecurring charge will apply at the time of the establishment of this feature. In addition to a flat monthly rate, a charge per telephone number to be redirected will apply. For changes made by the Company on behalf of the customer, rearrangement charges will apply. The monthly rate is based on the number of options in which the feature is used. This optional feature is available for Group Redirect only.

Time-of-Day/Day-of-Week

A nonrecurring charge will apply at the time of the establishment of this feature. In addition to a flat monthly rate, a charge per telephone number to be redirected will apply. For changes made by the Company on behalf of the customer, rearrangement charges will apply. The monthly rate is based on the number of options in which the feature is used. This optional feature is available for both Group Redirect and Flexible Call Forwarding.

<sup>1</sup> Effective December 15, 2005, Custom Routing Service is grandfathered and limited to existing customers at existing locations. No moves, changes or additions to existing service will be permitted.

Effective: April 1, 2016

CUSTOM ROUTING SERVICE <sup>1</sup>

IX. RATES AND CHARGES

A. Group Redirect

	<u>Nonrecurring Charge</u> <sup>2</sup>	<u>Monthly Rate</u> <sup>3</sup>
1. Type I		
Service Establishment	\$197.00	-
Per Line or DID Number <sup>4</sup>		
2 - 50	2.35	\$3.00
51 - 100	2.35	2.70
101 - 500	2.35	2.40
501 - 1000	2.35	2.10
1001 Plus	2.35	1.75
Rearrangements		
- System Charge, per Rearrangement	92.00	-
- Per Number Changed/Moved or Added	2.35	-
2. Type II		
Service Establishment	245.00	-
Per Trunk <sup>4</sup>		
2 - 10	5.30	8.25
11 - 50	5.30	8.00
51 - 100	5.30	7.75
101 - 250	5.30	7.50
251 - 500	5.30	7.25
501 Plus	5.30	7.00
Rearrangements		
- System Charge, per Rearrangement	102.00	-
- Per Trunk Changed/Moved or Added	5.30	-

<sup>1</sup> Effective December 15, 2005, Custom Routing Service is grandfathered and limited to existing customers at existing locations. No moves, changes or additions to existing service will be permitted.

<sup>2</sup> Nonrecurring charges in Section 3 of this Product Guide are applicable in addition to these charges.

<sup>3</sup> In addition to applicable Basic Exchange Access Line charges in Section 5 of this Product Guide, General Exchange Tariff, Schedule No. A-1 and/or the Centrex Line charges in Section 11 of this Product Guide.

<sup>4</sup> A termination liability is applicable.

Effective: April 1, 2016

CUSTOM ROUTING SERVICE <sup>1</sup>

IX. RATES AND CHARGES (Continued)

A. Group Redirect (Continued)

	<u>Nonrecurring Charge</u> <sup>2</sup>	<u>Monthly Rate</u> <sup>3</sup>
3. Group Charges		
First Group		NO EXTRA CHARGE
Each Additional Group or Supergroup	\$20.00	-
4. Optional Features		
(a) Incoming Number Identification Redirecting (Each 100 Numbers) Per Number	86.00 -	- \$0.30
(b) Percentage Redirecting, Per option Per Number	20.00 -	- 0.30
(c) Time-of-Day/Day-of-Week Redirection, per option Per Number	20.00 -	- 0.40

<sup>1</sup> Effective December 15, 2005, Custom Routing Service is grandfathered and limited to existing customers at existing locations. No moves, changes or additions to existing service will be permitted.

<sup>2</sup> Nonrecurring charges in Section 3 of this Product Guide are applicable in addition to these charges.

<sup>3</sup> In addition to applicable Basic Exchange Access Line charges in Section 5 of this Product Guide, General Exchange Tariff, Schedule No. A-1 and/or the Centrex Line charges in Section 11 of this Product Guide.

Effective: April 1, 2016

CUSTOM ROUTING SERVICE <sup>1</sup>

IX. RATES AND CHARGES (Continued)

	<u>Nonrecurring Charge</u> <sup>2</sup>	<u>Monthly Rate</u> <sup>3</sup>
B. Flexible Call Forwarding		
1. Type I		
Service Establishment	\$220.00	-
Per Line or DID Number <sup>4</sup>		
5 - 50	2.35	\$3.00
51 - 100	2.35	2.70
101 - 500	2.35	2.40
501 -1000	2.35	2.10
1001 Plus	2.35	1.75
2. Rearrangements		
- System Charge, per Rearrangement	92.00	-
- Per Number Changed, Moved or Added	2.35	-
3. Time-of-Day/Day-of-Week Redirection, per option		
Per Number	20.00 -	- .35
4. PIN Number Change (per occasion)		
	28.00	-

<sup>1</sup> Effective December 15, 2005, Custom Routing Service is grandfathered and limited to existing customers at existing locations. No moves, changes or additions to existing service will be permitted.

<sup>2</sup> Nonrecurring charges in Section 3 of this Product Guide are applicable in addition to these charges.

<sup>3</sup> In addition to applicable Basic Exchange Access Line charges in Section 5 of this Product Guide, General Exchange Tariff, Schedule No. A-1 and/or the Centrex Line charges in Section 11 of this Product Guide.

<sup>4</sup> A termination liability is applicable.

Effective: April 1, 2016

---

INTRALATA TOLL SERVICE

TABLE OF CONTENTS

	<u>SHEET NO.</u>
I. SPECIAL CONDITIONS	
A. Description	1
B. Terms and Conditions	1
C. Method of Applying Rates	2
II. RATES AND CHARGES	
A. Business Rate Schedule	10
B. Residence Rate Schedule	11
C. Calling Card Rate Schedule	12
D. Operator Handled Rate Schedule	14
E. Corrections Collect Rate Schedule	16
F. Coin Station Rate Schedule	17

Effective: April 1, 2016

---

INTRALATA TOLL SERVICE

I. SPECIAL CONDITIONS

A. Description

A toll telephone message is a completed call or telephonic communication between two exchange stations located in different local service areas, the rates for which are applicable in accordance with the provisions of this section.

B. Terms and Conditions

1. The toll service charges specified in this section are in payment for all service furnished between the calling and the called stations.
2. Toll service is classified and rated as either:
  - Business/Residence (Direct Dialed)
  - Calling Card
  - Operator Handled
  - Corrections Collect Service
  - Coin Station
3. Use of Service for Unlawful Purposes
  - Legal requirements for refusal or discontinuance of service are set forth in the General Exchange Tariff, Schedule D&R, Rule No. 10.
4. California relay service calls may not be placed to:
  - 976 or 900 numbers
  - Time or weather recorded messages
  - Other informational recordings
5. A credit per line for the amount charged by the Company will be issued to customers for the IntraLATA Primary Interexchange Carrier (IPIC) change charge when changing their IPIC to Frontier. This credit may be issued directly to the customer.

Effective: April 1, 2016

---

INTRALATA TOLL SERVICE

I. SPECIAL CONDITIONS (Continued)

C. Method of Applying Rates

1. Toll rates between points (cities, towns or localities) are based on the airline distance between rate centers. In general, each point is designated as a rate center; certain small towns or localities are assigned adjacent rate centers with which they are closely associated for communication purposes.
2. Determination of Airline Mileage
  - (a) Where a point is divided into district areas, the rate distance is the mileage between the rate center of the district area and the rate center of the other point. When such mileage exceeds 40 miles, the rate distance is the airline mileage between the exchange rate center and the rate center of the other point with a minimum of 41 miles.
  - (b) If both points are divided into district areas, the rate airline distance is the mileage between the rate centers of the district areas, except that when such mileage exceeds 40 miles the rate airline distance is the mileage between the exchange rate centers with a minimum of 41 miles.
  - (c) The information contained in the Toll Rate Guide in Pacific Bell's tariff Schedule Cal. P.U.C. No. A6.2.7.B. for the State of California, is used in conjunction with other rate quoting material to determine rates and charges.
  - (d) The Toll Rate Guide contains lists of rate centers, localities, central offices, hereinafter generally referred to as "points", Local Access and Transport Areas (LATAs), and Frontier Calling Areas, within the State of California with V&H (vertical and horizontal) coordinates for use in determining airline mileages for intraLATA toll services over the lines of the Company and of the companies with which it connects.
  - (e) The material is arranged as follows:
    - (1) Rate Centers are listed alphabetically in Pacific Bell's tariff.
    - (2) Localities are listed in alphabetically in Pacific Bell's tariff and are cross-referenced to the rate center with which they are associated.
    - (3) Central Offices are listed numerically by NPA (Numbering Plan Area) in Pacific Bell's tariff and are cross referenced to the rate center with which they are associated.
    - (4) Local Access and Transport Areas are listed numerically in Pacific Bell's tariff.
  - (f) The columns headed "LATA", "NPA" and "Central Office" in Pacific Bell's tariff contain the local access and transport area, numbering plan area and central office codes for each rate center.
  - (g) The columns headed "V" and "H" in Pacific Bell's tariff contain the vertical and horizontal coordinates for each rate center.
  - (h) The column headed "ID" in Pacific Bell's tariff contains an identifier when the vertical and horizontal coordinates are to be used only for a particular type of service.



Effective: April 1, 2016

---

INTRALATA TOLL SERVICE

I. SPECIAL CONDITIONS (Continued)

C. Method of Applying Rates (Continued)

2. Determination of Airline Mileage (Continued)

(i) Basis for V&H Coordinates

For the purpose of determining airline mileages, vertical and horizontal grid lines have been established across the United States. The spacing between adjacent vertical grid lines represents a distance of one coordinate unit. This unit is the square root of 0.1, expressed in statute miles. A four-digit vertical (V) and a four-digit horizontal (H) coordinate is computed for each rate center from its latitude and longitude location by use of appropriate map-projection equations. A pair of V&H coordinates locates a rate center for determining airline mileages at a particular intersection of an established vertical grid line with an established horizontal grid line. The distance between any two rate centers is the airline mileage computed as explained in C.2.(j) following.

To determine the V&H coordinates for a point, refer to Pacific Bell's tariff for the point in the column headed "Exchange-Rate Center". If the point is not listed, look for the name in the column headed "Locality" in Pacific Bell's tariff, determine the rate center and locate the latter in Pacific Bell's tariff. Central office codes listed in Pacific Bell's tariff may also be used to determine rate centers for use in determining rate distances for intraLATA toll services.

(j) Calculation of Airline Mileages

To determine the rate distance between any two rate centers, proceed as follows:

Step 1: Obtain the "V" and "H" coordinates for each rate center.

Step 2: Obtain the difference between the "V" coordinates of the two rate centers. Obtain the difference between the "H" coordinates.

The difference is always obtained by subtracting the smaller coordinate from the larger coordinate.

Step 3: Divide each of the differences obtained in Step 2. by three, rounding each quotient to the nearer integer.

Step 4: Square these two integers and add the two squares.

If the sum of the squares is greater than 1777, divide the integers obtained in Step 3. by three and repeat Step 4. Repeat this process until the sum of the squares obtained in Step 4 is less than 1778.

Effective: April 1, 2016

---

INTRALATA TOLL SERVICE

I. SPECIAL CONDITIONS (Continued)

C. Method of Applying Rates (Continued)

2. Determination of Airline Mileage (Continued)

(j) Calculation of Airline Mileages (Continued)

Step 5: The number of successive divisions by three in Steps 3. and 4. determines the value of "N". Multiply the final sum of the two squares obtained in Step 4. by the multiplier specified in the following table for this value of "N" preceding:

<u>N</u>	<u>MULTIPLIER</u>	<u>MINIMUM RATE MILEAGE</u>
1	0.9	-
2	8.1	41
3	72.9	121
4	656.1	361

Step 6: Obtain the square root of the product in Step 5. and with any resulting fraction, round up to the next higher integer. This is the message rate except when the mileage so obtained is less than the minimum rate mileage shown in Step 5. the minimum rate mileage corresponding to the "N" value is applicable.

Example:

The message rate distance is required between Los Angeles and San Francisco.

V      H

Step 1: Los Angeles    9213    7878  
San Francisco    8492    8719

Step 2: difference      721      841

Step 3a: dividing each difference by three and rounding to nearer integer = 240 and 280.

Effective: April 1, 2016

---

INTRALATA TOLL SERVICE

I. SPECIAL CONDITIONS (Continued)

C. Method of Applying Rates (Continued)

2. Determination of Airline Mileage (Continued)

(j) Calculation of Airline Mileages (Continued)

Step 4a: squaring integers and adding,  $240 \times 240 = 57,600$   
 $280 \times 280 = \underline{78,400}$   
sum of squared integers 136,000

sum of squared integers is greater than 1777, so divide integers in Step 3a. by three and repeat Step 4a.

Step 3b: dividing integers in Step 3a. by three and rounding = 80 and 93

Step 4b: squaring integers and adding,  $80 \times 80 = 6,400$   
 $93 \times 93 = \underline{8,649}$   
sum of squared integers = 15,049

sum of squared integers is greater than 1777, so divide integers in Step 3b. by three and repeat Step 4b.

Step 3c: dividing integers in Step 3b. by three and rounding = 27 and 31

Step 4c: squaring integers and adding,  $27 \times 27 = 729$   
 $31 \times 31 = \underline{961}$   
sum of squared integers = 1,690

This sum of squared integers is less than 1778 and was obtained after three successive divisions by three; therefore, "N" = 3.

Step 5: Multiply final sum of squared integers by factor 72.9 (corresponding to "N" = 3)

$1,690 \times 72.9 = 123,201.00$

Step 6: Square root of 123,201 = 351 miles. The 351 miles is larger than the minimum of 121 rate miles applicable when "N" = 3, so the message rate mileage is 351 miles.

INTRALATA TOLL SERVICE

I. SPECIAL CONDITIONS (Continued)

C. Method of Applying Rates (Continued)

3. Determination of Appropriate Rate

Opposite the mileage step which includes the mileage determined as in C.2. preceding will be found the rates for direct dial station-to-station and coin station-to-station service; initial periods and rates for additional minutes for all classes of service between the rate centers involved.

4. Rate Periods

<u>Hours</u>	<u>Rate</u>	
<u>Monday thru Friday</u>	8:00 am to 4:59:59 pm	Day
5:00 pm to 10:59:59 pm	Evening	
11:00 pm to 7:59:59 am	Night/Weekend	
<u>Saturday and Sunday</u>		
All	Night/Weekend	

5. Holidays

Night/Weekend rates apply on the following holidays:

New Year's Day	January 1
Washington's Birthday	3rd Monday in February
Independence Day	July 4
Labor Day	
Thanksgiving Day	
Christmas Day	December 25

6. Discounts for Certified Handicapped TDD Users

(a) Message telecommunications service rate periods and rate discount for households of certified handicapped TDD users as specified in the General Exchange Tariff, Schedule No. A-2 are as follows.

<u>Hours</u>	<u>Discount From</u>	
<u>Day Rate</u>		
<u>Monday thru Friday</u>	8:00 am to 4:59:59 pm	30%
5:00 pm to 10:59:59 pm	60%	
11:00 pm to 7:59:59 am	75%	
<u>Saturday, Sunday and Holidays<sup>1</sup></u>	All	75%

(b) TDD customers may obtain additional discounts in addition to the discounts listed above when subscribing to Discount Calling Plans.

<sup>1</sup> See C.5. preceding.

Effective: April 1, 2016

---

INTRALATA TOLL SERVICE

I. SPECIAL CONDITIONS (Continued)

C. Method of Applying Rates (Continued)

7. Business/Residence (Direct Dialed)

Business/Residence Direct Dial rates apply to:

Sent-Paid messages dialed and completed by the customer from a residence or business telephone without the assistance of a Company operator.

Sent-Paid placed with the assistance of an operator where:

- Dial completion facilities are not available.
- Equipment or circuit conditions cause unsuccessful dial attempts.
- The customers identify themselves as being handicapped and unable to dial.
- The Company operator must identify the calling number where automatic recording equipment is not available.
- The Company operator reestablishes the connection after a service failure on a customer dialed call.
- The California Relay Service communication assistant completes a call between a TDD and a non-TDD telephone.

8. Calling Card Service (Direct Dialed)

Direct Dial Calling Card Service applies to station-to-station calls where the originating call is completed without the assistance of an operator, where equipment is available. This service applies to calls that require operator assistance which is limited to an operator entering the Calling Card number to complete the call and recording the Calling Card number for billing purposes. <sup>1</sup> Frontier will accept Local Exchange Calling Cards, Interexchange Carrier Calling Cards, and/or Commercial Credit Cards where a contractual arrangement exists between the Company and card issuer.

- Dials the operator and places a Calling Card operator station service call when the equipment capability precludes either of the foregoing, or
- The customers identify themselves as being handicapped and unable to dial. Local coin sent-paid calls from a paystation are provided free of charge for California Relay Service customers.

9. Operator Handled Service

Operator Handled Services are provided from Section 18 of this Product Guide.

<sup>1</sup> This service includes calls made from a public telephone.

Effective: April 1, 2016

---

INTRALATA TOLL SERVICE

I. SPECIAL CONDITIONS (Continued)

C. Method of Applying Rates (Continued)

10. Corrections Collect Service

Operator Handled <sup>1</sup> Station-to-Station Service is for originating calls from a correctional facility utilizing special equipment to restrict calls to victims, witnesses, officers of the court, correctional officers, and others.

11. Collection of Charges

Charges for all classes of telephone calls are billed against or collected from the calling telephone number. However, upon request, calls between points within the Frontier Calling Area may be placed on a non sent-paid basis and long distance charges may be:

- Billed against or collected from the called telephone number, except a coin telephone number and a COPT telephone number (i.e., charges may be reversed) if the charges are accepted at the called station.
- Billed against or collected from a third telephone number or account, except a coin telephone number and a COPT telephone number anywhere in the United States or Canada where such billing is accepted at the third telephone.
- Exception - California Relay Service calls may only be billed to a third number within California
- Billed against another telephone company (credit) calling card account when the party requesting such billing is authorized to use such (credit) calling card.
- Exception - California Relay Service calls may only be billed to a calling card issued within California.

12. Time of Day and Day of Week

The rate applicable is determined by the day and time (standard or daylight savings) at the rate center of the calling station when the connection is established.

<sup>1</sup> Operator is mechanized; live operator is not provided.

Effective: March 1, 2018

---

INTRALATA TOLL SERVICE

I. SPECIAL CONDITIONS (Continued)

C. Method of Applying Rates (Continued)

13. Initial Period and Additional Minutes

Rates are quoted in terms of initial period and additional minutes.

Initial Minute:

Initial Minute rates shown II.RATES following are for connections of one minute or any fraction thereof.

- Business/Residence (Direct Dialed)
- Calling Card (Direct Dialed)
- Operator Handled
- Corrections Collect
- California Relay Service

Initial 3 Minute Period rates shown in II.E following are for connections of three minutes or any fraction thereof.

- Coin Station Service

Additional Minutes:

All additional minute rates as shown in II.A through II.E following, are for each additional minute or any fraction thereof that the connection continues beyond the initial period.

14. Timing of Messages - Chargeable Time

- Chargeable time for calls placed on a Direct Dialed Station-to-Station, Direct Dialed Calling Card, Operator Handled Station-to-Station, Operator Handled Corrections Collect, Operator Handled Coin Station-to-Station, Coin Station-to-Station, or California Relay Service basis begins when connection is established between the calling station and the called station.
- Chargeable time for calls placed on an Operator Handled Person-to-Person or Operator Handled Coin Person-to-Person basis begins when connection is established between the person calling and the particular person called, or another party acceptable to the person calling.
- Chargeable time for all messages ends when the calling station "hangs up" thereby releasing the network connection. If the called station "hangs up" but the calling station does not, chargeable time ends when the network connection is released either by automatic timing equipment in the telephone network or by the Company operator.

(D)  
(D)

15. The accumulated initial period charges and additional minute charges will be rounded to the nearest whole cent for each billed message.

(T)

Effective: April 1, 2016

---

INTRALATA TOLL SERVICE

II. RATES AND CHARGES

A. BUSINESS RATE SCHEDULE

1. Day Rates

<u>Initial Minute Rate Mileage</u>	<u>Each Additional (Direct Dialed)</u>	<u>Minute</u>
13-16	0.1900	0.1900
17-20	0.1900	0.1900
21-25	0.1900	0.1900
26-30	0.1900	0.1900
31-40	0.1900	0.1900
41-50	0.1900	0.1900
51-70	0.1900	0.1900
71 +	0.1900	0.1900

2. Evening Rates

<u>Initial Minute Rate Mileage</u>	<u>Each Additional (Direct Dialed)</u>	<u>Minute</u>
13-16	0.1900	0.1900
17-20	0.1900	0.1900
21-25	0.1900	0.1900
26-30	0.1900	0.1900
31-40	0.1900	0.1900
41-50	0.1900	0.1900
51-70	0.1900	0.1900
71 +	0.1900	0.1900

3. Night and Weekend Rates

<u>Initial Minute Rate Mileage</u>	<u>Each Additional (Direct Dialed)</u>	<u>Minute</u>
13-16	0.1900	0.1900
17-20	0.1900	0.1900
21-25	0.1900	0.1900
26-30	0.1900	0.1900
31-40	0.1900	0.1900
41-50	0.1900	0.1900
51-70	0.1900	0.1900
71 +	0.1900	0.1900



Effective: April 1, 2016

---

INTRALATA TOLL SERVICE

II. RATES AND CHARGES (Continued)

B. RESIDENCE RATE SCHEDULE

1. Day Rates			
Initial Minute		Each Additional	
<u>Rate Mileage</u>		<u>(Direct Dialed)</u>	<u>Minute</u>
13+		\$0.16	\$0.16
2. Evening Rates			
<u>Rate Mileage</u>		Initial Minute	Each Additional
13+		<u>(Direct Dialed)</u>	<u>Minute</u>
		\$0.13	\$0.13
3. Night and Weekend Rates			
<u>Rate Mileage</u>		Initial Minute	Each Additional
13+		<u>(Direct Dialed)</u>	<u>Minute</u>
		\$0.10	\$0.10

Effective: April 1, 2016

INTRALATA TOLL SERVICE

II. RATES AND CHARGES (Continued)

C. CALLING CARD RATE SCHEDULE <sup>1</sup>

1. Business

Day Rates	Initial Minute	Each Additional
<u>Rate Mileage</u>	<u>(Direct Dialed)</u> <sup>2</sup>	<u>Minute</u>
0-12	0.1700	0.1700
13-16	0.1700	0.1700
17-20	0.1700	0.1700
21-25	0.1700	0.1700
26-30	0.1700	0.1700
31-40	0.1700	0.1700
41-50	0.1700	0.1700
51-70	0.1700	0.1700
71 +	0.1700	0.1700

Evening Rates	Initial Minute	Each Additional
<u>Rate Mileage</u>	<u>(Direct Dialed)</u> <sup>2</sup>	<u>Minute</u>
0-12	0.1700	0.1700
13-16	0.1700	0.1700
17-20	0.1700	0.1700
21-25	0.1700	0.1700
26-30	0.1700	0.1700
31-40	0.1700	0.1700
41-50	0.1700	0.1700
51-70	0.1700	0.1700
71 +	0.1700	0.1700

Night and Weekend Rates	Initial Minute	Each Additional
<u>Rate Mileage</u>	<u>(Direct Dialed)</u> <sup>2</sup>	<u>Minute</u>
0-12	0.1700	0.1700
13-16	0.1700	0.1700
17-20	0.1700	0.1700
21-25	0.1700	0.1700
26-30	0.1700	0.1700
31-40	0.1700	0.1700
41-50	0.1700	0.1700
51-70	0.1700	0.1700
71 +	0.1700	0.1700

<sup>1</sup> The Pay Station Service Charge applies in addition to the Calling Card rate (see Section 20 for applicable rate).

<sup>2</sup> In addition to the Direct Dialed Rate, per message charges for Direct Dial Calling Card are applicable (see Section 20 of this Product Guide for applicable rates).

Effective: April 1, 2016

---

INTRALATA TOLL SERVICE

II. RATES AND CHARGES (Continued)

C. CALLING CARD RATE SCHEDULE <sup>1</sup> (Continued)

2. Residence

Day Rates

<u>Initial Minute (Direct Dialed)</u> <sup>2</sup>	<u>Each Additional Minute</u>
\$0.16	\$0.16

Evening Rates

<u>Initial Minute (Direct Dialed)</u> <sup>2</sup>	<u>Each Additional Minute</u>
\$0.13	\$0.13

Night and Weekend Rates

<u>Initial Minute (Direct Dialed)</u> <sup>2</sup>	<u>Each Additional Minute</u>
\$0.10	\$0.10

<sup>1</sup> The Pay Station Service Charge applies in addition to the Calling Card rate (see Product Guide Section 20 for applicable rates).

<sup>2</sup> In addition to the Direct Dialed Rate, per message charges for Direct Dial Calling Card are applicable (see Product Guide Section 20 for applicable rates).

Effective: April 1, 2016

INTRALATA TOLL SERVICE

II. RATES AND CHARGES (Continued)

D. OPERATOR HANDLED RATE SCHEDULE <sup>1</sup>

1. Business

Day Rates	Initial Minute	Each Additional
<u>Rate Mileage</u>	<u>(Direct Dialed)</u> <sup>2</sup>	<u>Minute</u>
0-12	0.1700	0.1700
13-16	0.1700	0.1700
17-20	0.1700	0.1700
21-25	0.1700	0.1700
26-30	0.1700	0.1700
31-40	0.1700	0.1700
41-50	0.1700	0.1700
51-70	0.1700	0.1700
71 +	0.1700	0.1700

Evening Rates	Initial Minute	Each Additional
<u>Rate Mileage</u>	<u>(Direct Dialed)</u> <sup>2</sup>	<u>Minute</u>
0-12	0.1700	0.1700
13-16	0.1700	0.1700
17-20	0.1700	0.1700
21-25	0.1700	0.1700
26-30	0.1700	0.1700
31-40	0.1700	0.1700
41-50	0.1700	0.1700
51-70	0.1700	0.1700
71 +	0.1700	0.1700

Night and Weekend Rates	Initial Minute	Each Additional
<u>Rate Mileage</u>	<u>(Direct Dialed)</u> <sup>2</sup>	<u>Minute</u>
0-12	0.1700	0.1700
13-16	0.1700	0.1700
17-20	0.1700	0.1700
21-25	0.1700	0.1700
26-30	0.1700	0.1700
31-40	0.1700	0.1700
41-50	0.1700	0.1700
51-70	0.1700	0.1700
71 +	0.1700	0.1700

<sup>1</sup> The Pay Station Service Charge applies in addition to the Operator Handled rate (see Section 20 of this Product Guide for applicable rate).

<sup>2</sup> In addition to the Direct Dialed Rate, per message charges for Operator Station-to-Station or Operator Person-to-Person Service are applicable (see Section 20 for applicable rates).

Effective: April 1, 2016

---

INTRALATA TOLL SERVICE

II. RATES AND CHARGES (Continued)

D. OPERATOR HANDLED RATE SCHEDULE <sup>1</sup> (Continued)

2. Residence

Day Rates <u>Rate Mileage</u>	Initial Minute <u>(Direct Dialed)</u> <sup>2</sup>	Each Additional <u>Minute</u>
	\$0.16	\$0.16
Evening Rates	Initial Minute <u>(Direct Dialed)</u> <sup>2</sup>	Each Additional <u>Minute</u>
	\$0.13	\$0.13
Night and Weekend Rates	Initial Minute <u>(Direct Dialed)</u> <sup>2</sup>	Each Additional <u>Minute</u>
	\$0.10	\$0.10

<sup>1</sup> The Pay Station Service Charge applies in addition to the Calling Card rate (see Product Guide Section 20 for applicable rates).

<sup>2</sup> In addition to the Direct Dialed Rate, per message charges for Direct Dial Calling Card are applicable (see Product Guide Section 20 for applicable rates).

Effective: April 1, 2016

INTRALATA TOLL SERVICE

II. RATES AND CHARGES (Continued)

E. CORRECTIONS COLLECT RATE SCHEDULE <sup>1</sup>

1. Business Day Rates

<u>Rate Mileage</u>	<u>Initial Minute</u>	Each Additional <u>Minute</u>
0-12	0.0700	0.0700
13-16	0.0700	0.0700
17-20	0.0700	0.0700
21-25	0.2000	0.2000
26-30	0.2000	0.2000
31-40	0.2000	0.2000
41-50	0.2000	0.2000
51-70	0.2000	0.2000
71 +	0.2000	0.2000

Evening Rates

<u>Rate Mileage</u>	<u>Initial Minute</u>	Each Additional <u>Minute</u>
0-12	0.0700	0.0700
13-16	0.0700	0.0700
17-20	0.0700	0.0700
21-25	0.2000	0.2000
26-30	0.2000	0.2000
31-40	0.2000	0.2000
41-50	0.2000	0.2000
51-70	0.2000	0.2000
71 +	0.2000	0.2000

Night and Weekend Rates

<u>Rate Mileage</u>	<u>Initial Minute</u>	Each Additional <u>Minute</u>
0-12	0.0700	0.0700
13-16	0.0700	0.0700
17-20	0.0700	0.0700
21-25	0.2000	0.2000
26-30	0.2000	0.2000
31-40	0.2000	0.2000
41-50	0.2000	0.2000
51-70	0.2000	0.2000
71 +	0.2000	0.2000

<sup>1</sup> In addition to the above usage rates, Pay Station Service Charges and Corrections Collect Service Charges are also applicable (see Section 20 of this Product Guide).

Effective: April 1, 2016

INTRALATA TOLL SERVICE

II. RATES AND CHARGES (Continued)

F. COIN STATION RATE SCHEDULE

1. Day Rates

<u>Rate Mileage</u>	Initial 3-Minute Period (Sent Paid)	Each Additional Minute
13-16	0.3000	0.0500
17-20	0.3000	0.0500
21-25	0.4000	0.1000
26-30	0.4000	0.1000
31-40	0.4000	0.1000
41-50	0.4500	0.1500
51-70	0.4500	0.1500
71 +	0.5000	0.1500

Evening Rates

<u>Rate Mileage</u>	Initial 3-Minute Period (Sent Paid)	Each Additional Minute
13-16	0.2500	0.0500
17-20	0.2500	0.0500
21-25	0.3000	0.1000
26-30	0.3000	0.1000
31-40	0.3000	0.1000
41-50	0.3500	0.1000
51-70	0.3500	0.1000
71 +	0.4000	0.1000

Night and Weekend Rates

<u>Rate Mileage</u>	Initial 3-Minute Period (Sent Paid)	Each Additional Minute
13-16	0.2000	0.0500
17-20	0.2000	0.0500
21-25	0.2500	0.0500
26-30	0.2500	0.0500
31-40	0.2500	0.0500
41-50	0.2500	0.1000
51-70	0.2500	0.1000
71 +	0.3000	0.1000

Effective: April 1, 2016

---

CUSTOMER OWNED PAY TELEPHONE (COPT) SERVICE

TABLE OF CONTENTS

	<u>SHEET NO.</u>
I. GENERAL	
A. Special Conditions	1
B. Optional Features	6
C. Compensable Call Tracking Report (CCT)	6
II. RATES AND CHARGES	
A. COPT Service	7
B. Call Restriction Services	7
C. Optional Features	7
D. Billing and Collecting of Pay Station Service Charge	7
E. Compensable Call Tracking Report (CCT)	7
III. COIN LINE SERVICE	
A. Definitions and Requirements	8
B. Features	8
C. Responsibility of the Subscriber	9
D. Rate Conditions	9
E. Rates and Charges	9



Effective: April 1, 2016

---

CUSTOMER OWNED PAY TELEPHONE (COPT) SERVICE

I. GENERAL

A. SPECIAL CONDITIONS

1. Connection of Customer-Owned Pay Telephones to the Company's Public Switched Network
  - a. A Customer-Owned Pay Telephone may be connected to the Company's public switched network. A line connecting a customer-owned pay telephone set is a business class service.
  - b. COPT providers who connect COPTs to the Company's network must comply with the terms and conditions of Decision No. 85-11-057 of November 13, 1985, Decision No. 86-01-059 of January 23, 1986, and Decision 90-06-018 of June 6, 1990. Copies of the CPUC's rules and regulations regarding the aforementioned decisions may be obtained from the Company.
2. Screening/Blocking
  - a. Call screening and blocking are the responsibility of the COPT provider. Subscription to Call Restriction Option II and Call Restriction Option IV and Option V of Section 5, General Services, Custom Calling Services or Billed Number Screening of this section, is optional. The Company recommends when connecting a customer-owned pay telephone to the switched network that the customer subscribe to Call Restriction Option II and Call Restriction Option V or Billed Number Screening in exchanges in which those services can be provided. Coin Line Service includes the cost for providing call screening.
  - b. If Billed Number Screening or Call Restriction Option II and Call Restriction Option V are not available in an exchange in which a customer wants to connect a customer-owned pay telephone or if the customer chooses not to subscribe to these services, the pay telephone may be connected, but the Company will not refund or credit the customer for calls made from the customer's line or other calls billed to the customer's line.
3. Refunds/Credits

The Company will not offer refunds/credits to either customer or clients (end users) of customers with individual line service connected to a customer-owned pay telephone set.

Effective: April 1, 2016

---

CUSTOMER OWNED PAY TELEPHONE (COPT) SERVICE

I. GENERAL (Continued)

A. SPECIAL CONDITIONS (Continued)

4. Responsibility of the COPT Provider

- a. The COPT provider will be responsible for payment of appropriate charges for 411 Directory Assistance Service. Directory Assistance Service will be billed to the subscriber in accordance with the rates and conditions set forth in Section 19, Directory Services.
- b. Rating of calls made from a COPT is the responsibility of the provider.
- c. The COPT provider will be responsible for installing in a well-lighted location adjacent to each COPT a clearly legible, permanently printed sign indicating the following:
  - (1) Toll free telephone number and address of COPT.
  - (2) Dialing instructions.
    - Dialing Sequence
    - Dial O to reach LEC operator
    - Access to long distance operator (00)
    - 1+ and 0+ instructions
  - (3) Rates for local calls.
  - (4) Time limits of local calls.
  - (5) Telephone number to dial to obtain rates for non-local calls.
  - (6) 711 is a free call to TRS/CRS.
  - (7) Placement of local calls by use of 101XXXX, Calling Card or Operator Handled Services may be more expensive than directly dialing the number.
  - (8) Restrictions to or blocking of incoming calls.
  - (9) The name, address, and telephone number of the owner/operator and the repair service telephone number and refund telephone number.
  - (10) Procedures for registering complaints and requesting refunds.
  - (11) No charge telephone numbers (611, 711, 911, COPT vendor provided number for refunds, repair and complaints).
  - (12) The name of the provider of operator services.
  - (13) The name of the long-distance provider (optional).
  - (14) Telephone number/or identification and address of pay telephone.
- d. Each COPT Provider shall permit the following at no cost to the end users:
  - (1) Access to the Company's operators for emergency purposes or zero-minus calling.
  - (2) Access to 911 Emergency Service, where available.
  - (3) Access to 611 repair service.
  - (4) Access to 711 Telecommunications Relay Service.
  - (5) 950-XXXX calling, where facilities permit.
  - (6) 101XXXX calling, if available.
  - (7) 800-XXX-XXXX type calling (i.e., 855, 866, 877, 888).
  - (8) Access to 0+ and IntraLATA and InterLATA.

Effective: April 1, 2016

---

CUSTOMER OWNED PAY TELEPHONE (COPT) SERVICE

I. GENERAL (Continued)

A. SPECIAL CONDITIONS (Continued)

4. Responsibility of the COPT Provider (Continued)

e. COPT Providers may program a COPT to:

- (1) allow local calls of unlimited duration, or
- (2) limit call duration to no less than fifteen minutes or to require coin deposits after each fifteen-minute interval for a local call.

f. COPT providers must comply with CPUC General Order 107-B, Rules and Regulations concerning the Privacy of Telephone Communications.

g. COPT providers must submit a new application form to the Company upon transferring the ownership of, relocating, or replacing a COPT. Service may be terminated for violation of any of the Product Guide conditions.

h. The COPT provider will be responsible for payment of local and ZUM usage rates and Company and interexchange carrier toll rates for all sent-paid calls originated from the COPT. In addition, COPT providers (including COPT Coin Line Service) are responsible for payment of the following monthly rates per line:

(1) Public Policy Payphone Program Fee	\$0.00
(2) Operator Services Zero-Minus Cost Fee	0.00

The sum of the monthly fees plus the amounts equal to the monthly rates for blocking and screening services shall not exceed \$9.00 per month.

i. Before connection of a COPT for public use, the COPT provider must complete and submit an application form to the Company.

j. COPT providers are eligible to subscribe to Discount Calling Plans where technology is feasible. Discount Calling Plan usage may be aggregated for a single billed telephone number as described in Section 17, Frontier Calling Plans.

5. All conditions of Section 19, Directory Services, apply to customers connecting customer-owned pay telephone sets to an individual-line business service.

6. All appropriate charges in Section 3, Service Charges apply, except as shown below:

a. Supersedures will be charged \$12.26 per line.

b. All other record-type only changes will be charged \$11.11 per line. See Section 3 for Subsequent Order Special Conditions.

---

CUSTOMER OWNED PAY TELEPHONE (COPT) SERVICE

I. GENERAL (Continued)

A. SPECIAL CONDITIONS (Continued)

7. An Inside Wire Maintenance Plan (IWMP) is not available to a COPT provider connecting a COPT to the Company's network.
8. COPT instruments for public use may not be connected to a Centrex line. COPT lines may only be aggregated behind a PBX if the PBX/COPT configuration allows identification of the geographical origin of emergency calls to the same extend currently allowed for more conventional telephones. This limit does not apply to Inmate Service. It is the COPT provider's responsibility to ensure that the configuration complies with this requirements. COPT Coin Line Service may not be connected behind a PBX.
9. Boothing associated with COPTs must comply with all applicable Federal, State, and Local laws, rules, and regulations concerning use of COPTs by disabled and hearing impaired persons.
10. COPTs must return coins deposited if a call is not completed. The COPT provider must make refunds available to the caller if the COPT fails to return coins, the quality of the transmission is poor, disconnection is premature, or service is affected by other problems.
11. The terms and conditions of this section apply to coin-operated and coinless COPTs.
12. The Company will not provide operator assistance for coin sent-paid calls originating from a COPT due to technical limitations.
13. Calls placed from a coinless COPT may be routed in the following manner: from the instrument to the Company's central office via a business line established for COPT Service, to the COPT provider's processor from the Company's central office via an additional line or other exchange facility, and back to the Company's central office via exchange facilities. IntraLATA 101XXXX, Calling Card and Operator Handled calls will then be completed by the LEC, Intra- or interexchange carrier (IC) of the customer's choice. IntraLATA 0- calls will be routed to the LEC's Operator until 7/1/95. IntraLATA 1+ calls will be completed over the Company's network.
14. Each coinless COPT which is connected to the Company's central office, when activated by a commercial credit card, may be programmed to automatically dial a number associated with a Company access facility (e.g., Feature Group B) purchased from the Company by an IC designated by the COPT provider providing the coinless, commercial credit-card-activated telephone. Calls will be routed from the COPT to the Company's central office via a business line and from the Company's central office to the IC via the access facility. Calls will then be routed to the COPT provider's processor via a connection to be arranged between the COPT provider and the IC. InterLATA calls may be routed from the customer's processor back to the IC for completion. IntraLATA calls must be routed to the Company's central office for completion.
15. In the configuration described in I.A.13 preceding, the COPT provider understands and agrees that access charges will apply, and will be payable by the IC designated by the COPT provider to the Company, for all calls directed to the IC's customer designated location (CDL) from the COPT, including the intraLATA calls.

Effective: April 1, 2016

CUSTOMER OWNED PAY TELEPHONE (COPT) SERVICE

I. GENERAL (Continued)

A. SPECIAL CONDITIONS (Continued)

16. The COPT provider may connect a call processor to the Company's central office via a business line established for COPT service. Line charges as shown in Section 4, Local Exchange Service of this Product Guide, apply for these connections in addition to the business line charge for a connection of a COPT to the Company's central office.
17. A direct connection from a COPT to an IC or to a remote call processor and then to an IC is not permitted.
18. Audits
  - a. The COPT provider is responsible for the cost of an initial audit of the remote call processor software to ensure intraLATA calls are routed to the Company's transmission facilities. These audits shall be conducted by an independent auditor acceptable to both the Company and the COPT provider. The Company will not provide the auditor with the instructions to govern the audit.
  - b. Subsequent audits of the remote call processor software and billing data may be conducted by an independent auditor whenever the Company has reason to believe that intraLATA calls are not routed properly. The cost of these audits shall be shared equally between the Company and the COPT provider.
19. The Company will allow consolidated billing of COPT Services provided by a single COPT owner. If one COPT service among those consolidated for billing is not paid, then only that COPT service may be disconnected for non-payment. The COPT provider is responsible for letting the Company know about discrepancies.
20. COPT Providers are required to true up their coin toll rates to match the Company's rates that are in effect on January 1 of each year. This reconciliation is to be done by February 1 of each year.
21. Access to sent-paid and non-sent-paid calling, and local, IntraLATA toll, and InterLATA calling, requirements by type of pay phone:

	<u>LOCAL</u>		<u>INTRALATA</u>	<u>TOLL / INTERLATA</u>
	<u>Sent Paid</u>	<u>Non-Sent Paid</u>	<u>Sent Paid</u>	<u>Non-Sent Paid</u>
Coin- Single Denomination	X	X		X
Coin-Multiple Denomination	X	X	X	X
Non-Coin		X		X
Universal Coin/Credit	X	X	X	X

Effective: April 1, 2016

---

CUSTOMER OWNED PAY TELEPHONE (COPT) SERVICE

I. GENERAL (Continued)

A. SPECIAL CONDITIONS (Continued)

22. Billing and Collecting of Pay Station Service Charge  
(See Section 20, Operator Services)

- a. The Company will process call information recorded by the Company.
- b. The Company will bill and collect the Pay Station Service Charge, as authorized in D.90-06-018, for customers connecting a COPT to the Company's network, as specified in this section.
- c. The Company will bill and collect only for zero-plus (0+) non-sent-paid calls and will not bill and collect for zero-minus (0-) calls.
- d. Billing and Collecting Service will be provided for calls which originate and terminate within the same LATA.
- e. The Company will bill and collect only a Pay Station Service Charge as specified in Section 20, Operator Services.
- f. The back billing limitations specified in the General Exchange Tariff, Schedule D&R, Rule No. 9 apply to billing and collection of the Pay Station Service Charge.

B. OPTIONAL FEATURES

1. Answer Supervision

Answer Supervision is the line side functionality that provides an electrical signal to the calling end of a switched telephone connection when the called line goes off-hook. COPT Answer Supervision will be provided for use with COPT Service as specified in this section to assist in determining when billing for a specific call should commence.

2. Billed Number Screening (BNS) is an interactive operator screening service which disallows other calling parties to bill collect or third-party calls to a telephone number in the BNS database tables. BNS alerts an operator to restrict billing of incoming calls to the payphone line.

C. COMPENSABLE CALL TRACKING REPORT (CCT)

The Compensable Call Tracking (CCT) Report provides a tracking mechanism for Independent Payphone Providers (IPPs) to utilize in tracking compensable calls. This report reflects the number of call attempts made on a carrier's network, segmented into four duration categories: 0-14 seconds, 15-29 seconds, 30-44 seconds, and 45 seconds and up. This report does not identify whether calls are completed.

The CCT Report is available to all IPPs who lease access lines through the Company and is provided on a quarterly basis. Charges are applicable on a per pay phone basis.

Effective: April 1, 2016

CUSTOMER OWNED PAY TELEPHONE (COPT) SERVICE

II. RATES AND CHARGES

	<u>Nonrecurring Charge</u>	<u>Monthly Rate</u>
A. COPT Service <sup>1, 2, 3</sup>		\$ 24.89
COPT Service <sup>1, 2, 4</sup>		29.75
B. Call Restriction Services		
1. Option II	5	1.99
2. Option IV		1.99
3. Option V	5	
4. Billed Number Screening	\$ 11.11 <sup>6</sup>	.31
C. Optional Features		
1. Answer Supervision, per line		3.94
D. Billing and Collecting of Pay Station Service Charge (See Section 18, Operator Services)		
E. Compensable Call Tracking Report (CCT)	<u>Nonrecurring Charge Per Pay Phone</u>	
One Time Set-Up Charge		
1 - 100 Pay Phones, per Pay Phone	\$ 1.00	
101 - 999 Pay Phones, per Pay Phone	.75	
1000 - plus Pay Phones, per Pay Phone	.50	
		<u>Quarterly Rate</u>
Quarterly Recurring Charge, per Pay Phone		.25

<sup>1</sup> Plus Extended Area Service increments as identified in Section 4, Local Exchange Service.

<sup>2</sup> The COPT Surcharge (I.A.4.h) is also applicable.

<sup>3</sup> Rates are applicable to customers in exchanges listed in Section 5, Sheet 2.

<sup>4</sup> Rates are applicable to customers in exchanges listed in Section 5, Sheet 3.

<sup>5</sup> Applicable rates are set forth in Section 7 of this Product Guide.

<sup>6</sup> Rate is applicable only if service is added on Subsequent Order after line is initially installed.

Effective: April 1, 2016

---

CUSTOMER OWNED PAY TELEPHONE (COPT) SERVICE

III. COIN LINE SERVICE

A. DEFINITIONS AND REQUIREMENTS

1. Customer-Owned Pay Telephone (COPT) Coin Line Service is a coin voice grade exchange line that provides switch based dial tone first (DTF) coin line functionalities for non-local Exchange Company customer-owned pay telephones.
2. COPT Coin Line Service is provided at the request of a COPT provider that provides pay telephone service with switch based coin line functionalities to the public on a resale basis.
3. A COPT Coin Line subscriber must use a separate COPT Coin Line for each pay telephone instrument installed and will be billed the rate in this section for each line. Off-premise extensions to a COPT Coin Line are not permitted.
4. Where COPT Coin Line Service is provided, any type or grade of residence or business service offered regularly at that location may also be furnished, provided such residence or business service is confined to locations solely for use by the particular establishment.
5. The Company shall not be liable for shortages of coins deposited and/or collected from the COPT Coin Line subscriber's equipment.
6. The Company shall not be liable for end-user fraud associated with failure of the subscriber's equipment to perform.
7. COPT Coin Line Service will be provided from central offices where facilities are available.

B. FEATURES

1. Service is provided in equal access Stored Program Control (SPC) central offices where coin line control equipment is available.
2. Service is provided on a one-way or a two-way basis at the customer's option.
3. Coin signaling, including coin collect and coin return, is provided by the network. Coin collect identifies when a call is completed. Coin return occurs when a no answer or busy signal is encountered.
4. Billed Number Screening (BNS) is provided for the automatic blocking via validation data bases of third number billing, collect billing, or both to the line.
5. Selective Class of Call Screening is provided to alert operator services systems (live and mechanical) that a call is originating from a COPT Coin Line which may require special handling and billing treatment.
6. Central office 900 and 976 blocking is provided.
7. Standard recorded announcements used for calls from the Company's Public Telephone Service pay telephones are used for calls that originate from a COPT Coin Line.
8. Coin Line Service includes rating of calls, but sent-paid local calls may be rated by the COPT Coin Line subscriber. End user charges for coin sent-paid calls and directory assistance are deregulated pursuant to FCC Decision CC Docket 96-128, XXX XX,XX.



Effective: March 1, 2018

---

CUSTOMER OWNED PAY TELEPHONE (COPT) SERVICE

III. COIN LINE SERVICE (Continued)

C. RESPONSIBILITY OF THE SUBSCRIBER

1. The subscriber is subject to the requirements for COPT Service as set forth in I.A.
2. The subscriber is responsible for the payment of all charges for outgoing sent-paid local calls and message toll telephone service calls.
3. Special billing and coin sharing arrangements between a COPT Coin Line Subscriber and another carrier are the responsibility of the COPT Coin Line subscriber.
4. It is the subscriber's responsibility to ensure instruments used in conjunction with the COPT Coin Line Service are compatible with the Company's network.

D. RATE CONDITIONS

1. No charge will be imposed for incoming calls.
2. Sent-paid local calls will be rated by the Central Office.
3. Operator assisted sent-paid local calls will be rated to the end-user at the appropriate additive operator service charges as specified in Section 20, Operator Services. Non-sent paid local calls will be rated to the end-user at the appropriate additive operator service charges as specified in Section 18, Operator Services.
4. Operator assisted sent-paid IntraLATA toll calls will be rated to the end-user at the IntraLATA toll rate, plus the appropriate additive operator service charges as specified in Section 18, Operator Services. Non-sent paid IntraLATA toll calls will be rated to the end-user at the IntraLATA toll rate, plus the appropriate additive operator service charges as specified in Section 20, Operator Services.
5. The appropriate Service Order Activity, Central Office Activity, and/or Premises Visit Charge as specified in Section 3, Service Charges, are applicable for each COPT Coin Line installed, moved, or changed, except as shown below:
  - a. Supersedures will be charged \$12.26 per line.
  - b. All other record-type only changes will be charged \$11.11 per line. See Section 3, Service Charges for Subsequent Order Special Conditions.

(D)

E. RATES AND CHARGES

1. COPT Coin Line Service is provided on a Fixed Rate basis. The following monthly rate is applicable for COPT Coin Line Service on a per-line basis.

	<u>MONTHLY RATE</u>
(a) Coin Line, per line	\$26.45

Effective: April 1, 2016

---

WIDE AREA TELECOMMUNICATIONS (WATS) AND 800 SERVICES<sup>1,2,3</sup>

TABLE OF CONTENTS

	<u>SHEET NO.</u>
I. APPLICABILITY	1
II. TERRITORY	1
III. SPECIAL CONDITIONS	
A. General	1
B. WATS	10
C. Dedicated 800 Service	12
D. Business/Residence Line 800 Service	17
IV. RATES AND CHARGES	
A. WATS	20
B. Dedicated 800 Service	21
C. Business/Residence Line 800 Service	23
D. Ancillary Services	26

<sup>1</sup> Intrastate intraLATA Wide Area Telecommunications Service (WATS) is grandfathered and limited to existing customers at existing locations as of January 13, 2005.

<sup>2</sup> Effective November 3, 2012 moves, additions or changes to business subscribers' existing service are not permitted. Intrastate intraLATA Wide Area Telecommunications Service (WATS) continues to be available for resale until February 16, 2013, on which date the foregoing terms shall be effective for resale.

<sup>3</sup> Effective November 3, 2012, 800 Services are grandfathered and limited to existing business customers at existing locations. Moves, additions or changes to business subscribers' existing service are not permitted. 800 Services continue to be available for resale until February 16, 2013, on which date the foregoing terms shall be effective for resale.

Effective: April 1, 2016

---

WIDE AREA TELECOMMUNICATIONS (WATS) AND 800 SERVICES<sup>1, 2, 3</sup>

I. APPLICABILITY

Applicable to intrastate intraLATA Wide Area Telecommunications Service (WATS) and 800 Services, furnished or made available over facilities by Frontier hereinafter referred to as the Company, and in conjunction with any interexchange carrier which elects to offer interLATA service on the basis hereinafter set forth.

Special Note:

Rates, charges and conditions shown herein include all network facilities on the Company's side of the Local Loop Demarcation Point (LLDP). The purpose of the LLDP is to separate responsibility of the Company from the responsibility of the building owner/customer.

The Company will provide WATS and Dedicated 800 Service in conjunction with an Interexchange Carrier using a common access line. The Company will provide the intraLATA portion and the Interexchange Carrier will provide the interLATA portion. The access line will be owned by the Company.

II. TERRITORY

Within the exchange areas of all exchanges as said areas are defined on maps as part of this Product Guide.

III. SPECIAL CONDITIONS

A. GENERAL

1. Description

(a) WATS Service is a dedicated access line arranged to allow outgoing calls to a specified geographical subscription area, at volume discounted toll usage rates.

(b) Dedicated 800 Service is provisioned on a dedicated access line arranged to allow incoming calls from a specific subscription area, at no charge to the calling party.

(c) Business/Residence Line 800 Service allows a customer to terminate an 800/888 Service on a regular business, PBX, or Centrex line, thereby eliminating the need for a dedicated line.

<sup>1</sup> Intrastate intraLATA Wide Area Telecommunications Service (WATS) is grandfathered and limited to existing customers at existing locations as of January 13, 2005.

<sup>2</sup> Effective November 3, 2012, moves, additions or changes to business subscribers' existing Intrastate intraLATA Wide Area Telecommunications Service (WATS) are not permitted. Intrastate intraLATA Wide Area Telecommunications Service (WATS) continues to be available for resale until February 16, 2013, on which date the foregoing terms shall be effective for resale.

<sup>3</sup> Effective November 3, 2012, 800 Services are grandfathered and limited to existing business customers at existing locations. Moves, additions or changes to business subscribers' existing service are not permitted. 800 Services continue to be available for resale until February 16, 2013, on which date the foregoing terms shall be effective for resale.

Effective: April 1, 2016

---

WIDE AREA TELECOMMUNICATIONS (WATS) AND 800 SERVICES<sup>1, 2, 3</sup>

III. SPECIAL CONDITIONS (Continued)

A. GENERAL (Continued)

2. Terms and Conditions

(a) Advance Payments

- (1) Applicants for service may be required to make an advance payment at the time of application, equal to the installation charges, if applicable, and the rate for one month for the service desired.
- (2) The amount of the advance payment is credited to the customer's account as applying to any indebtedness for the service furnished.

(b) Allowance For Interruptions

An allowance for interruptions applies to each WATS, or Dedicated 800 Service access line as set forth in (1) thru (4) below:

- (1) When a line is interrupted for a period of less than two hours, no credit applies.
- (2) When a line is interrupted for a period of 2 to 24 hours, and for each additional 24 hour period, a credit of one day, per 24 hour period as covered in III.A.2.(j). following applies.
- (3) No credit allowances will be made for:
  - Non-completion of messages due to busy network conditions.
  - Interruption of service due to customer-provided equipment or systems.
  - Interruption of service due to wire or standard jacks on the customer's side of the Company's local loop demarcation point.
  - Interruption of service due to the negligence of the customer.
  - Interruption of service during any period in which the Company is not afforded access to the premises at which the access line is terminated.
  - Interruption of service during any period when the customer has released the access line to the Company for maintenance purposes, or implementation of a customer order for a change in service arrangement.
- (4) IntraLata Toll Service furnished at a customer's request when their service is interrupted is charged at the IntraLata Toll Service rates contained in Section 16 of this Product Guide.

<sup>1</sup> Intrastate intraLATA Wide Area Telecommunications Service (WATS) is grandfathered and limited to existing customers at existing locations as of January 13, 2005.

<sup>2</sup> Effective November 3, 2012, moves, additions or changes to business subscribers' existing Intrastate intraLATA Wide Area Telecommunications Service (WATS) are not permitted. Intrastate intraLATA Wide Area Telecommunications Service (WATS) continues to be available for resale until February 16, 2013, on which date the foregoing terms shall be effective for resale.

<sup>3</sup> Effective November 3, 2012, 800 Services are grandfathered and limited to existing business customers at existing locations. Moves, additions or changes to business subscribers' existing service are not permitted. 800 Services continue to be available for resale until February 16, 2013, on which date the foregoing terms shall be effective for resale.

Effective: April 1, 2016

---

WIDE AREA TELECOMMUNICATIONS (WATS) AND 800 SERVICES <sup>1, 2, 3</sup>

III. SPECIAL CONDITIONS (Continued)

A. GENERAL (Continued)

2. Terms and Conditions (Continued)

(c) Applications

Applications for new service, moves or changes of existing service that are cancelled, modified or deferred by the applicant or customer, shall be subject to those provisions shown in the General Exchange Tariff, Schedule D&R, Rule No. 2.

(d) Area of Service

All WATS and Dedicated 800 Service access lines and additional terminations must be located in the same LATA for which the access line is arranged.

(e) Chargeable Time (Timing of Messages)

- (1) Chargeable time begins when connection is established between a telephone station associated with the access line and the calling or called station.
- (2) Chargeable time ends when the calling station "hangs up" thereby releasing the network connection. If the called station "hangs up" but the calling station does not, chargeable time ends when the network connection is released by automatic timing equipment in the telecommunications network.
- (3) Charges for messages beginning in one time period and completing in another time period, are determined by applying the appropriate rate for the portion of the message occurring in each period.
- (4) Elapsed time is measured separately for each message and accumulated in increments of one-tenth minute with fractions of a tenth-minute rounded to the next higher tenth minute. Minutes and tenths of minute are summed by rate period and chargeable hours determined rounded to the nearest tenth hour.

(f) Customer-Provided Equipment

Customer provided equipment or protective circuitry may be connected at the Company's local loop demarcation point to WATS or 800 Service in accordance with provisions of the California Public Utilities Commission's Certification Program or the Federal Communications Commission's Registration Program as are now in effect or may become effective. The customer-provided equipment shall be interconnected in accordance with the provisions set forth in the General Exchange Tariff, Schedule D&R, Rule No. 34.

<sup>1</sup> Intrastate intraLATA Wide Area Telecommunications Service (WATS) is grandfathered and limited to existing customers at existing locations as of January 13, 2005.

<sup>2</sup> Effective November 3, 2012, moves, additions or changes to business subscribers' existing Intrastate intraLATA Wide Area Telecommunications Service (WATS) are not permitted. Intrastate intraLATA Wide Area Telecommunications Service (WATS) continues to be available for resale until February 16, 2013, on which date the foregoing terms shall be effective for resale.

<sup>3</sup> Effective November 3, 2012, 800 Services are grandfathered and limited to existing business customers at existing locations. Moves, additions or changes to business subscribers' existing service are not permitted. 800 Services continue to be available for resale until February 16, 2013, on which date the foregoing terms shall be effective for resale.

Effective: April 1, 2016

---

WIDE AREA TELECOMMUNICATIONS (WATS) AND 800 SERVICES<sup>1,2,3</sup>

III. SPECIAL CONDITIONS (Continued)

A. GENERAL (Continued)

2. Terms and Conditions (Continued)

(g) Defacement of Premises

The Company is not liable for any defacement of or damage to the premises of a customer resulting from the existence of Company facilities on such premises or by the installation or removal thereof, when such defacement or damage is not the result of negligence of the Company.

(h) Denial and Discontinuance of Service

Service to applicants may be denied and service of customers may be discontinued in accordance with the provisions of the General Exchange Tariff, Schedule D&R, Rule No. 10.

(i) Deposits

An applicant for service may be required to make a deposit in accordance with requirements of the General Exchange Tariff, Schedule D&R, Rule No. 6.

(j) Fractional Periods (Other than Usage)

The charge for a fractional part of a month will be a proportionate part of the monthly recurring charge based on the actual number of days the service is provided.

For the purpose of administering this regulation with respect to the determination of the charge for a fractional part of a month, every month is considered to have 30 days.

(k) Limitations of Service

(1) Dial-Type Service

WATS and 800 Service calls must be dialed and completed without the assistance of a Company operator except when facilities or conditions do not allow customer dial completion.

(2) Local Directory Assistance Service (WATS) - Calls to Directory Assistance (normally accessed by dialing 411) are denied.

(3) Calls on WATS to California 900, California 976 and 900 IEC programs are denied except in those central offices where blocking is not technically feasible.

<sup>1</sup> Intrastate intraLATA Wide Area Telecommunications Service (WATS) is grandfathered and limited to existing customers at existing locations as of January 13, 2005.

<sup>2</sup> Effective November 3, 2012, moves, additions or changes to business subscribers' existing Intrastate intraLATA Wide Area Telecommunications Service (WATS) are not permitted. Intrastate intraLATA Wide Area Telecommunications Service (WATS) continues to be available for resale until February 16, 2013, on which date the foregoing terms shall be effective for resale.

<sup>3</sup> Effective November 3, 2012, 800 Services are grandfathered and limited to existing business customers at existing locations. Moves, additions or changes to business subscribers' existing service are not permitted. 800 Services continue to be available for resale until February 16, 2013, on which date the foregoing terms shall be effective for resale.

Effective: April 1, 2016

---

WIDE AREA TELECOMMUNICATIONS (WATS) AND 800 SERVICES<sup>1, 2, 3</sup>

III. SPECIAL CONDITIONS (Continued)

A. GENERAL (Continued)

2. Terms and Conditions (Continued)

(l) Minimum Service Period

The minimum service period for Wide Area Telecommunications Service<sup>1</sup> is one day.

(m) Fraudulent Use

A WATS or 800 Service call may be not be made in response to an uncompleted long distance call placed to send information and to avoid the Long Distance Service Charge.

(n) Indemnity

The Company shall be indemnified and saved harmless by the customer against claims for libel, slander or the infringement of copyright arising directly or indirectly from the material transmitted over the facilities or the use thereof, against claims for infringement of patents arising from combining with, or using in conjunction with, facilities furnished by the Company, apparatus and systems of the customer; and against all other claims arising out of any act or omission of the customer in connection with the services and facilities provided by the Company.

(o) Maintenance and Repairs

All ordinary expense of maintenance and repair of facilities provided by the Company up to and including its local loop demarcation point is borne by the Company. In case of damage to or destruction of facilities of the Company due to the negligence of the customer and not to ordinary wear and tear, or in the case of theft of such facilities, the customer is responsible for the cost of replacing the facilities destroyed or stolen or for the cost of restoring the facility to its original condition. Customers may not rearrange, disconnect, remove or attempt to repair any facilities installed by the Company on the Company's side of the local loop demarcation point or permit others to do so, except upon the written consent of the Company.

(p) Payment for Service

The customer is required to pay all rates and charges for service in accordance with the Company's regular billing and collection practices as covered in the General Exchange Tariff, Schedule D&R, Rule No. 9.

<sup>1</sup> Intrastate intraLATA Wide Area Telecommunications Service (WATS) is grandfathered and limited to existing customers at existing locations as of January 13, 2005.

<sup>2</sup> Effective November 3, 2012, moves, additions or changes to business subscribers' existing Intrastate intraLATA Wide Area Telecommunications Service (WATS) are not permitted. Intrastate intraLATA Wide Area Telecommunications Service (WATS) continues to be available for resale until February 16, 2013, on which date the foregoing terms shall be effective for resale.

<sup>3</sup> Effective November 3, 2012, 800 Services are grandfathered and limited to existing business customers at existing locations. Moves, additions or changes to business subscribers' existing service are not permitted. 800 Services continue to be available for resale until February 16, 2013, on which date the foregoing terms shall be effective for resale.

Effective: April 1, 2016

---

WIDE AREA TELECOMMUNICATIONS (WATS) AND 800 SERVICES<sup>1, 2, 3</sup>

III. SPECIAL CONDITIONS (Continued)

A. GENERAL (Continued)

2. Terms and Conditions (Continued)

(q) Power Supply

When Company equipment installed on the premises of a customer requires power for its operation, the customer is required to provide such power.

(r) Subscription Area

(1) Each WATS and Dedicated 800 Service access line for Metro, LATA, Half State and Full State is arranged for one subscription area, as requested by the customer. Specific subscription areas available are in III.B.2.(e) and III.C.2.(a) following.

(2) Rate centers and central office codes for each LATA are found in Pacific Bell's Schedule Cal. P.U.C. No. A6.2.7.B Message Toll Telephone Service - Toll Rate Guide for the State of California.

(s) Service Components (Facilities)

WATS and 800 Services are furnished only if the necessary service components are available.

(t) Service used for Dataphone Transmission

WATS and 800 Service is available for use with data transmission and receiving equipment (including telewriter equipment) and teletypewriter equipment for the transmission and reception of data signals. Data Transmission and Receiving equipment will be provided by the customer.

(u) Set-Up Charge

On WATS, Metro, LATA, Half State and Full State 800 Service all messages will be billed a set-up charge as shown in IV.B.2.(a), Rates and Charges. Northern California Half State, Southern California Half State, Full State and Dedicated 800 bills with a minimum of 100 hours usage in a monthly billing period are not assessed the Set-up charge as shown in IV.B.2.(a), Rates and Charges.

(v) Transmission Quality

Satisfactory transmission cannot be assured on the customer's side of the Company's local loop demarcation point where the dedicated access line is connected to other Company services or the customer-provided equipment or services.

<sup>1</sup> Intrastate intraLATA Wide Area Telecommunications Service (WATS) is grandfathered and limited to existing customers at existing locations as of January 13, 2005.

<sup>2</sup> Effective November 3, 2012, moves, additions or changes to business subscribers' existing Intrastate intraLATA Wide Area Telecommunications Service (WATS) are not permitted. Intrastate intraLATA Wide Area Telecommunications Service (WATS) continues to be available for resale until February 16, 2013, on which date the foregoing terms shall be effective for resale.

<sup>3</sup> Effective November 3, 2012, 800 Services are grandfathered and limited to existing business customers at existing locations. Moves, additions or changes to business subscribers' existing service are not permitted. 800 Services continue to be available for resale until February 16, 2013, on which date the foregoing terms shall be effective for resale.



Effective: April 1, 2016

---

WIDE AREA TELECOMMUNICATIONS (WATS) AND 800 SERVICES<sup>1, 2, 3</sup>

III. SPECIAL CONDITIONS (Continued)

A. GENERAL (Continued)

2. Terms and Conditions (Continued)

(w) WATS/800 Service Terminations

- (1) The terminating point of a dedicated-access line is a standard network interface (SNI). One termination is the dedicated access line. All other terminations on the same line are additional terminations. Such terminations must be within the same LATA as the original termination point.

Terminal equipment, e.g., customer provided multi-line terminating systems or a communication system on the customer's premises, may be connected on the customer's side of the network interface.

- (2) The dedicated access line may also terminate in one of the following:

- Switching equipment in the Company central office.
- Other Common Carrier (OCC) Central Office Connecting Facility (COCF) channels in the Company central office.

(x) Subscription Area Changes

Service Charges are applicable as specified in Section 3 of this Product Guide.

(y) Use of the Service by the Customer

The service is provided only for communications in which the customer has direct interest and shall not be used for any purpose for which a payment or other direct compensation shall be received by them from any other person, firm or corporation for such use, or in the collection, transmission or delivery of any communication for others, including personal communications of employees of the customer, except when WATS is used:

- (1) For public telegram message service or for overseas data message service.
- (2) By message forwarding service in receiving and forwarding messages for its transient clients. However, WATS cannot be used to establish a connection between two parties, neither of whom is the WATS customer.
- (3) By composite data service vendor for sending data (non-voice) communications for its customers.

<sup>1</sup> Intrastate intraLATA Wide Area Telecommunications Service (WATS) is grandfathered and limited to existing customers at existing locations as of January 13, 2005.

<sup>2</sup> Effective November 3, 2012, moves, additions or changes to business subscribers' existing Intrastate intraLATA Wide Area Telecommunications Service (WATS) are not permitted. Intrastate intraLATA Wide Area Telecommunications Service (WATS) continues to be available for resale until February 16, 2013, on which date the foregoing terms shall be effective for resale.

<sup>3</sup> Effective November 3, 2012, 800 Services are grandfathered and limited to existing business customers at existing locations. Moves, additions or changes to business subscribers' existing service are not permitted. 800 Services continue to be available for resale until February 16, 2013, on which date the foregoing terms shall be effective for resale.

Effective: April 1, 2016

---

WIDE AREA TELECOMMUNICATIONS (WATS) AND 800 SERVICES<sup>1,2,3</sup>

III. SPECIAL CONDITIONS (Continued)

A. GENERAL (Continued)

2. Terms and Conditions (Continued)

(z) Four-Wire Terminating Arrangement

(1) Provision of Four-Wire Terminating Arrangements

- Four-wire terminating arrangements on dedicated lines may be provided at Rates and Charges shown in IV.D.2.c. up to and including the Company's local loop demarcation point. This charge is in addition to the access line monthly rate and applies to each access line so arranged.
- In addition to the rates and charges above, the access line installation charge, as shown in Section 3 of this Product Guide applies to each access line so arranged.

(2) Change To or From Four-Wire Terminating Arrangement

- From a two-wire access line to a four-wire terminating arrangement at the Company's local loop demarcation point, the charge for each arrangement is the same as that for a new installation of an access line and a four-wire terminating arrangement. This charge applies to each access line so arranged.
- From a four-wire terminating arrangement to a two-wire access line up to and including the Company's local loop demarcation point, the charge for each access line is the same as that for a new installation of an access line.

(aa) Hunting Rearrangement

Service Charges as shown in Section 3 of this Product Guide apply to:

- (1) Separating an existing Dedicated 800 Service group into two or more hunting arrangements which contain the same 800 Service access lines as the original hunting arrangement, and a new hunting arrangement is being established.
- (2) Combining two or more Dedicated 800 Service hunting arrangements containing the same Dedicated 800 Service access lines.

<sup>1</sup> Intrastate intraLATA Wide Area Telecommunications Service (WATS) is grandfathered and limited to existing customers at existing locations as of January 13, 2005.

<sup>2</sup> Effective November 3, 2012, moves, additions or changes to business subscribers' existing Intrastate intraLATA Wide Area Telecommunications Service (WATS) are not permitted. Intrastate intraLATA Wide Area Telecommunications Service (WATS) continues to be available for resale until February 16, 2013, on which date the foregoing terms shall be effective for resale.

<sup>3</sup> Effective November 3, 2012, 800 Services are grandfathered and limited to existing business customers at existing locations. Moves, additions or changes to business subscribers' existing service are not permitted. 800 Services continue to be available for resale until February 16, 2013, on which date the foregoing terms shall be effective for resale.

Effective: April 1, 2016

---

WIDE AREA TELECOMMUNICATIONS (WATS) AND 800 SERVICES<sup>1,2,3</sup>

III. SPECIAL CONDITIONS (Continued)

A. GENERAL (Continued)

2. Terms and Conditions (Continued)

(bb) Signaling - See Section 3 of this Product Guide for rates.

(1) Signaling Operation Changes

Change of method of signaling operation on the access line from loop start to ground start or from ground start to loop start. (These terms refer to the method of obtaining dial tone.)

(2) Signal Power Level Adjustments

Basis for Charge

- Work is associated with acoustic or inductive connection of an access line or additional termination (access line extension) to customer provided terminal equipment.
- Customer changes equipment at a specified location.
- Visit to the customer's premises by Company personnel is needed to coordinate the necessary adjustments and testing.

(3) All wire, cable, jacks and equipment beyond the Company's local loop demarcation point are the customer's responsibility.

<sup>1</sup> Intrastate intraLATA Wide Area Telecommunications Service (WATS) is grandfathered and limited to existing customers at existing locations as of January 13, 2005.

<sup>2</sup> Effective November 3, 2012, moves, additions or changes to business subscribers' existing Intrastate intraLATA Wide Area Telecommunications Service (WATS) are not permitted. Intrastate intraLATA Wide Area Telecommunications Service (WATS) continues to be available for resale until February 16, 2013, on which date the foregoing terms shall be effective for resale.

<sup>3</sup> Effective November 3, 2012, 800 Services are grandfathered and limited to existing business customers at existing locations. Moves, additions or changes to business subscribers' existing service are not permitted. 800 Services continue to be available for resale until February 16, 2013, on which date the foregoing terms shall be effective for resale.

Effective: April 1, 2016

---

WIDE AREA TELECOMMUNICATIONS (WATS) AND 800 SERVICES<sup>1,2,3</sup>

III. SPECIAL CONDITIONS (Continued)

B. WATS

1. Description

The WATS customer is furnished a WATS access line arranged for outward calling only. WATS provides for directly dialed telephone calling from a WATS termination by way of the WATS access line and the public switched network to other locations in the same subscription area as that in which the access line terminates.

2. Terms and Conditions

(a) Area of Service

A WATS message must originate and terminate in the WATS subscription area for which the access line is arranged.

(b) Rate Structure

- (1) Monthly usage charges for a service group are computed on an average usage per line basis according to a tapered schedule. There is no minimum monthly usage requirement. Hourly rates for each hour of use decrease at defined levels of use called taper points.
- (2) This schedule requires a separate monthly charge for each access line in a service group independent of usage.
- (3) In addition to the charges described elsewhere, a Set-Up charge applies to each message, whether dialed by the customer or Company operator as provided in III.A.2., Limitations of Service, preceding.

(c) Service Group

The term "Service Group", as used in connection with WATS, denotes one or more access lines for the same subscription area appearing in the same multiline system terminating on the customer's side of the Company's local loop demarcation point.

<sup>1</sup> Intrastate intraLATA Wide Area Telecommunications Service (WATS) is grandfathered and limited to existing customers at existing locations as of January 13, 2005.

<sup>2</sup> Effective November 3, 2012, moves, additions or changes to business subscribers' existing Intrastate intraLATA Wide Area Telecommunications Service (WATS) are not permitted. Intrastate intraLATA Wide Area Telecommunications Service (WATS) continues to be available for resale until February 16, 2013, on which date the foregoing terms shall be effective for resale.

<sup>3</sup> Effective November 3, 2012, 800 Services are grandfathered and limited to existing business customers at existing locations. Moves, additions or changes to business subscribers' existing service are not permitted. 800 Services continue to be available for resale until February 16, 2013, on which date the foregoing terms shall be effective for resale.

Effective: April 1, 2016

---

WIDE AREA TELECOMMUNICATIONS (WATS) AND 800 SERVICES<sup>1,2,3</sup>

III. SPECIAL CONDITIONS (Continued)

B. WATS (Continued)

2. Terms and Conditions (Continued)

(d) Usage Charges

Method of determining usage charges for WATS:

- (1) Note the total actual hours to be billed for the service group.
- (2) Determine the chargeable hours rounded to the nearest tenth (one decimal place) for the service group. See III.B.2.(c). preceding.
- (3) Determine the number of access lines in the service group in service during the month. Access lines in service for a fraction of a month are based on the number of days in service divided by 30 days. The result is rounded to the nearest hundredth (two decimal places).
- (4) Determine the average hours of use per line in the service group by dividing the chargeable hours in (2) above, by the number of access lines in (3) above. The result is rounded to the nearest hundredth of an hour.
- (5) Determine the usage charge per line by multiplying the hourly rate for the appropriate taper(s) by the number of hours used in each taper and then totaling these charges. The result is rounded to the nearest cent.
- (6) Determine the total usage charge for the service group by multiplying the usage charge per access line in (5) above by the number of access lines in (3) above. The result is rounded to the nearest cent.

<sup>1</sup> Intrastate intraLATA Wide Area Telecommunications Service (WATS) is grandfathered and limited to existing customers at existing locations as of January 13, 2005.

<sup>2</sup> Effective November 3, 2012, moves, additions or changes to business subscribers' existing Intrastate intraLATA Wide Area Telecommunications Service (WATS) are not permitted. Intrastate intraLATA Wide Area Telecommunications Service (WATS) continues to be available for resale until February 16, 2013, on which date the foregoing terms shall be effective for resale.

<sup>3</sup> Effective November 3, 2012, 800 Services are grandfathered and limited to existing business customers at existing locations. Moves, additions or changes to business subscribers' existing service are not permitted. 800 Services continue to be available for resale until February 16, 2013, on which date the foregoing terms shall be effective for resale.

Effective: April 1, 2016

---

WIDE AREA TELECOMMUNICATIONS (WATS) AND 800 SERVICES<sup>1,2,3</sup>

III. SPECIAL CONDITIONS (Continued)

B. WATS (Continued)

2. Terms and Conditions (Continued)

(e) Subscription Area

California has the following WATS Subscription Areas:

LATA<sup>2</sup>

California Northern Half State<sup>2</sup>: 209-408-415-707-916

California southern Half State<sup>2</sup>: 213-310-619-714-805-818

Full State<sup>3</sup>: All of the above NPAs

- (f) Frontier Calling Services may be arranged to work with WATS service where facilities and conditions permit. Service will be administered and provisioned as set forth in Section 7 and 8 of this Product Guide.

C. DEDICATED 800 SERVICE

1. Description

- (a) 800 Service Customer - The Dedicated 800 Service customer is furnished a dedicated access line arranged for inward calling only. The Dedicated 800 Service customer is furnished an 800 number that when dialed from within the subscribed area(s), calls are routed via the public switched network to the terminating access line(s) associated with the 800 number at no charge to the calling party.

<sup>1</sup> Intrastate intraLATA Wide Area Telecommunications Service (WATS) is grandfathered and limited to existing customers at existing locations as of January 13, 2005.

<sup>2</sup> LATA WATS service is only available where facilities and conditions permit.

<sup>3</sup> Calls dialed with the incorrect NPA will be routed to intercept.

<sup>4</sup> Effective November 3, 2012 moves, additions or changes to business subscribers' existing service are not permitted. Intrastate intraLATA Wide Area Telecommunications Service (WATS) continues to be available for resale until February 16, 2013, on which date the foregoing terms shall be effective for resale.

<sup>5</sup> Effective November 3, 2012, 800 Services are grandfathered and limited to existing business customers at existing locations. Moves, additions or changes to business subscribers' existing service are not permitted. 800 Services continue to be available for resale until February 16, 2013, on which date the foregoing terms shall be effective for resale.

Effective: April 1, 2016

---

WIDE AREA TELECOMMUNICATIONS (WATS) AND 800 SERVICES <sup>1,2,3</sup>

III. SPECIAL CONDITIONS (Continued)

C. DEDICATED 800 SERVICE (Continued)

2. Terms and Conditions

Area of Service

- (1) A Dedicated 800 Service message must originate and terminate in the 800 Service subscription area for which the Dedicated 800 Service access line is arranged.
- (2) Metro 800 Service access lines are provided for intraLATA only 800 Service calling <sup>1</sup>. The Metro 800 Service offering is limited to the following LATAs.

Northern California <sup>2</sup>  
LATA #1 (San Francisco)  
NPA 415, 510 and 707

Southern California <sup>2</sup>  
LATA #5 (Los Angeles)  
NPA 213, 310, 714, 818

- (3) Subscription Area - California has the following Dedicated 800 Service Subscription Areas:

Metro 800: See IV.C.2.(a)(2). preceding  
California Northern Half State <sup>2</sup>: 209-408-415-707-916  
California Southern Half State <sup>2</sup>: 213-310-619-714-  
805-818  
Full State <sup>6</sup>: All of the above NPAs

- (b) Directory Listings - Directory Listings for Dedicated 800 Service lines will be provided at rates applicable for business additional listings as covered in Section 19 of this Product Guide.
- (c) Line Hunt Service - The rate for each Dedicated 800 Service Line arranged for line hunt service will be as set forth in Section 4 of this Product Guide
- (d) Calling Party Identification - Calling party identification is not available on Dedicated 800 service.

<sup>1</sup> NPA 408 in Northern California and NPAs 619 and 805 in Southern California are not included in this offering. Metro 800 Service can be purchased in these NPA areas; however, calls originating within NPAs 408, 619 and 805 cannot be received in their respective LATAs.

<sup>2</sup> Calls dialed with the incorrect NPA will be routed to intercept.

<sup>3</sup> Intrastate intraLATA Wide Area Telecommunications Service (WATS) is grandfathered and limited to existing customers at existing locations as of January 13, 2005.

<sup>4</sup> Effective November 3, 2012 moves, additions or changes to business subscribers' existing service are not permitted. Intrastate intraLATA Wide Area Telecommunications Service (WATS) continues to be available for resale until February 16, 2013, on which date the foregoing terms shall be effective for resale.

<sup>5</sup> Effective November 3, 2012, 800 Services are grandfathered and limited to existing business customers at existing locations. Moves, additions or changes to business subscribers' existing service are not permitted. 800 Services continue to be available for resale until February 16, 2013, on which date the foregoing terms shall be effective for resale.

Effective: April 1, 2016

---

WIDE AREA TELECOMMUNICATIONS (WATS) AND 800 SERVICES<sup>1, 2, 3</sup>

III. SPECIAL CONDITIONS (Continued)

C. DEDICATED 800 SERVICE (Continued)

2. Terms and Conditions (Continued)

(3) Subscription Area - California has the following Dedicated 800 Service Subscription Areas: (Continued)

(e) Denial and Discontinuance of Service

Dedicated 800 Service is furnished upon the condition that the customer obtain adequate service to permit the use of the service without injurious effect upon it or any other service rendered by the Company. The Company may terminate or refuse to furnish 800 Service to any customer, without incurring any liability, if the use of the service would interfere with or impair WATS<sup>1</sup> or any other service rendered by the Company. In the case of a termination of service, at least five days must elapse following written notification to the customer by mail or in person of the Company's intention to terminate the service for such cause. This notice need not be given by the Company in the case of any emergency which, in the judgment of the Company renders immediate discontinuance of service.

(f) Impairment of Service

(1) A Dedicated 800 Service customer must subscribe to and make use of a sufficient number of access lines so that use of the service does not interfere with another customer's service or proper operation of the public switched network.

(2) Any arrangement permitting customer control of the number of messages completed to a Dedicated 800 Service access line is not permitted.

(g) Service Group

The term "Service Group" as used in connection with Dedicated 800 Service, denotes the access lines for the same subscription area arranged in central office equipment furnished by the Company as part of a given hunting arrangement. (The term "hunting arrangement" denotes a grouping of Dedicated 800 Service access lines arranged for the completion of a given call or arranged for overflow to or from another access line or group of access lines.)

<sup>1</sup> Intrastate intraLATA Wide Area Telecommunications Service (WATS) is grandfathered and limited to existing customers at existing locations as of January 13, 2005.

<sup>2</sup> Effective November 3, 2012 moves, additions or changes to business subscribers' existing service are not permitted. Intrastate intraLATA Wide Area Telecommunications Service (WATS) continues to be available for resale until February 16, 2013, on which date the foregoing terms shall be effective for resale.

<sup>3</sup> Effective November 3, 2012, 800 Services are grandfathered and limited to existing business customers at existing locations. Moves, additions or changes to business subscribers' existing service are not permitted. 800 Services continue to be available for resale until February 16, 2013, on which date the foregoing terms shall be effective for resale.



Effective: April 1, 2016

---

WIDE AREA TELECOMMUNICATIONS (WATS) AND 800 SERVICES<sup>1, 2, 3</sup>

III. SPECIAL CONDITIONS (Continued)

C. DEDICATED 800 SERVICE (Continued)

2. Terms and Conditions (Continued)

- (h) Rates Periods - Rates applicable to Dedicated 800 Service are based on the time of day or day of week as follows:

Rate Group

Northern California Half State, Southern California  
Half State, Full State Metro, LATA and Dedicated 800

Business day period

9:00am to 9:00pm<sup>1</sup> Monday through Friday

Discount Period

All other hours

Calls completed on any Holiday listed in Section 16 of this Product Guide are billed at discount period rates.

(i) Telephone Numbers

- (1) Telephone Number Change - When changing a Dedicated 800 Service telephone number to a different number at the request of the customer, service charges are applicable as specified in Section 3 of this Product Guide.

- (2) Telephone Number Retention - Customers may retain the same 800 Service telephone number when moving to another location.

(j) Usage Charges

Method of determining usage charge for Half State, Full State, or Metro 800 service:

- (1) Determine the total actual hours to be billed for each rate period for each service group.
- (2) Determine the chargeable hours rounded to the nearest tenth (one decimal place) for each rate period for each service group. See III.B.2.(e). preceding.
- (3) Determine the total usage charge by multiplying the hourly rate for the appropriate rate period by the number of chargeable hours in each rate period and then totaling these charges. The applicable hourly rate for Northern California Half State, Southern California Half State, Full State, or Metro 800 is dependent upon whether or not the minimum requirement of 100 hours of usage in a monthly billing period has been met.

<sup>1</sup> To, but not including.

<sup>2</sup> Intrastate intraLATA Wide Area Telecommunications Service (WATS) is grandfathered and limited to existing customers at existing locations as of January 13, 2005.

<sup>3</sup> Effective November 3, 2012 moves, additions or changes to business subscribers' existing service are not permitted. Intrastate intraLATA Wide Area Telecommunications Service (WATS) continues to be available for resale until February 16, 2013, on which date the foregoing terms shall be effective for resale.

<sup>4</sup> Effective November 3, 2012, 800 Services are grandfathered and limited to existing business customers at existing locations. Moves, additions or changes to business subscribers' existing service are not permitted. 800 Services continue to be available for resale until February 16, 2013, on which date the foregoing terms shall be effective for resale.

Effective: April 1, 2016

---

WIDE AREA TELECOMMUNICATIONS (WATS) AND 800 SERVICES<sup>1,2,3</sup>

III. SPECIAL CONDITIONS (Continued)

C. DEDICATED 800 SERVICE (Continued)

2. Terms and Conditions (Continued)

(k) Optional Features on a Dedicated 800 Service Line

(1) The following optional features available with Centrex service, may be arranged with the specific associated restrictions, for use in conjunction with 800 Service.

- Call Pick Up
- Call Transfer (to another Station Line in the same Centrex System)
- Call Forwarding - Don't Answer (to another Station line in the same Centrex System)
- Call Forwarding - Variable (forward calls only within the Centrex system)

Descriptions, special conditions, charges and rates are set forth in Section 11 of this Product Guide apply.

(2) Frontier Calling Services may be arranged to work with Dedicated 800 Services where facilities and conditions permit. Service will be administered and provisioned as set forth in Section 7 and 8 of this Product Guide.

(l) Rate Structure

(1) The usage rate structure for Dedicated 800 Service is on a fixed rate per hour basis with a reduced rate for discount period. A reduced business day period rate is also applied to Northern California Half State, Southern California Half State, Pull State and Metro 800 bills with a minimum of 100 hours usage on a monthly bill.

(2) Monthly usage charges for a service group are computed on a total usage basis according to a fixed schedule. There is no minimum monthly usage charge.

(3) This schedule requires a separate monthly charge for each access line in a service group independent of usage.

(4) For Half State, Full State and Metro in addition to the charges described preceding, a set up charge described in IV.B.2.(a) applies to each message, whether dialed by a caller or the Company operator as provided for in III.A.2.(k), Limitations of Service, Northern California Half State, Southern California Half State, Pull State and Metro 800 bills with a minimum of 100 hours usage in a monthly billing period are not assessed the set up charge.

<sup>1</sup> Intrastate intraLATA Wide Area Telecommunications Service (WATS) is grandfathered and limited to existing customers at existing locations as of January 13, 2005.

<sup>2</sup> Effective November 3, 2012 moves, additions or changes to business subscribers' existing service are not permitted. Intrastate intraLATA Wide Area Telecommunications Service (WATS) continues to be available for resale until February 16, 2013, on which date the foregoing terms shall be effective for resale.

<sup>3</sup> Effective November 3, 2012, 800 Services are grandfathered and limited to existing business customers at existing locations. Moves, additions or changes to business subscribers' existing service are not permitted. 800 Services continue to be available for resale until February 16, 2013, on which date the foregoing terms shall be effective for resale.

Effective: April 1, 2016

---

WIDE AREA TELECOMMUNICATIONS (WATS) AND 800 SERVICES <sup>1, 2, 3</sup>

III. SPECIAL CONDITIONS (Continued)

D. BUSINESS/RESIDENCE <sup>4</sup> LINE 800 SERVICE

1. Description

- (a) Business/Residence Line 800 Service allows a customer to terminate an 800/888 service on a regular, PBX, or Centrex business line, thereby eliminating the need for a dedicated line. This service provides for directly dialed telephone calling via the public switched network from other locations within the same subscription area as that in which the business line terminates. Business/Residence Line 800 charges will be in addition to the applicable line or trunk rate.
- (b) When a customer subscribes to additional service areas, the Company will provide Business/Residence Line 800 Service in conjunction with an Interexchange Carrier. The Company will provide the intraLATA portion and the Interexchange Carrier will provide the interLATA portion. For the interLATA service which the Interexchange Carrier provides, the nonrecurring charges and monthly recurring charges of the Interexchange Carrier will apply.
- (c) Rates within this section are applicable only to dial type telecommunications from stations within the LATA to a station associated with an 800/888 termination point within the same LATA.
- (d) Dial type telecommunication is a call dialed and completed to Business/Residence Line 800 Service without the assistance of a Company operator or placed with an operator where facilities are not available for dial completion or where, for other service reasons, operator assistance in completion of the call is necessary.
- (e) Discount Plans are available for customers who sign up for one, two, or three years of service. Nonrecurring charges and usage will be discounted as specified in the rates section. Customers who sign a term agreement for one, two, or three years of service will also receive a unique ringing signal at no additional charge. The unique ringing signal will enable the customer to distinguish if the incoming call was placed by dialing the 800/888 number or the customer's local exchange number. This will be provided on only one termination and only where facilities and conditions permit.
- (f) Termination Liability - If a customer terminates service prior to the expiration date of the agreement, the customer's agreement period to date usage will be re-rated at the month-to-month rate, up to a maximum of twelve months, and the payments made to date shall be deducted from the re-rated total. The customer's termination liability would be the difference between these two figures.

<sup>1</sup> Intrastate intraLATA Wide Area Telecommunications Service (WATS) is grandfathered and limited to existing customers at existing locations as of January 13, 2005.

<sup>2</sup> Effective November 3, 2012 moves, additions or changes to business subscribers' existing service are not permitted. Intrastate intraLATA Wide Area Telecommunications Service (WATS) continues to be available for resale until February 16, 2013, on which date the foregoing terms shall be effective for resale.

<sup>3</sup> Effective November 3, 2012, 800 Services are grandfathered and limited to existing business customers at existing locations. Moves, additions or changes to business subscribers' existing service are not permitted. 800 Services continue to be available for resale until February 16, 2013, on which date the foregoing terms shall be effective for resale.

<sup>4</sup> Effective November 16, 2013, Residence Line 800 Services is no longer available for purchase. Existing customers of record may retain these services at existing locations in accordance with the terms and conditions described herein. Service is not offered for new installations, moves, changes, or additions.

Effective: April 1, 2016

---

WIDE AREA TELECOMMUNICATIONS (WATS) AND 800 SERVICES<sup>1,2,3</sup>

III. SPECIAL CONDITIONS (Continued)

D. BUSINESS/RESIDENCE<sup>4</sup> LINE 800 SERVICE (Continued)

1. Description (Continued)

- (g) Conversions - During an agreement period, the customer may elect to convert to a new agreement period of the same or different length. Conversion to a new agreement period will be allowed without penalty if the expiration date of the new agreement period is greater than the remainder of the original agreement period.
- (h) Variable Call Destination (VCD) - provides for multiple terminations of an IntraLATA 800 Number when the customer has requested termination of that number in more than one LATA or within the same LATA. All charges associated with the VCD will be charged to the subscriber of the Business/Residence Line 800 Service.

2. Terms and Conditions

- (a) This section contains specific conditions related to Business/Residence Line 800 Service. These conditions apply in addition to general terms and conditions applicable to WATS and Dedicated 800 Service unless otherwise indicated.
- (b) Business/Residence Line 800 Service calls may not be terminated to dedicated 800/888 access lines.
- (c) Only one 800/888 number will be assigned to terminate calls on any given exchange telephone service facility.
- (d) Business/Residence Line 800 Service is not available with semi-public, public, or public access line service.
- (e) Custom calling features, as shown in Section 7 and 8 of this Product Guide, for Frontier Calling Services are available where facilities and operating conditions permit.
- (f) Directory Listings for Business/Residence Line 800 Service will be provided at rates applicable for business additional listings as covered in Section 21 of this Product Guide.
- (g) Customers who change from Dedicated 800 Service to Business/Residence Line 800 Service are subject to applicable charges as shown in Section IV.C., Rates and Charges, in lieu of the Nonrecurring charges in Section 3 of this Product Guide.
- (h) Variable Call Destination is a Business/Residence Line 800 Service optional feature which provides for multiple terminations of an 800 Number when the customer has requested termination of that number in more than one LATA or within the same LATA.

<sup>1</sup> Intrastate intraLATA Wide Area Telecommunications Service (WATS) is grandfathered and limited to existing customers at existing locations as of January 13, 2005.

<sup>2</sup> Effective November 3, 2012 moves, additions or changes to business subscribers' existing service are not permitted. Intrastate intraLATA Wide Area Telecommunications Service (WATS) continues to be available for resale until February 16, 2013, on which date the foregoing terms shall be effective for resale.

<sup>3</sup> Effective November 3, 2012, 800 Services are grandfathered and limited to existing business customers at existing locations. Moves, additions or changes to business subscribers' existing service are not permitted. 800 Services continue to be available for resale until February 16, 2013, on which date the foregoing terms shall be effective for resale.

<sup>4</sup> Effective November 16, 2013, Residence Line 800 Services is no longer available for purchase. Existing customers of record may retain these services at existing locations in accordance with the terms and conditions described herein. Service is not offered for new installations, moves, changes, or additions.

Effective: April 1, 2016

---

WIDE AREA TELECOMMUNICATIONS (WATS) AND 800 SERVICES<sup>1,2,3</sup>

III. SPECIAL CONDITIONS (Continued)

D. BUSINESS/RESIDENCE<sup>4</sup> LINE 800 SERVICE (Continued)

2. Terms and Conditions (Continued)

- (i) All charges associated with Variable Call Destination will be billed to the Business/Residence Line 800 Number.
- (j) Customers routing calls to different terminating locations have an option of selecting from the following parameters:
  - Time of Day
  - Day of the Week
  - Originating Area Code, Area Code and Prefix, or Service Area
  - Specific date (within the next 12 months)
  - Allocation to terminating location by percentage of calls
  - Multiple Carriers

3. Determination of Charges

- (a) Determine the chargeable hours rounded to the nearest tenth (one decimal place) for each rate period for each 800/888 number. See III.A.2.(e). preceding.
- (b) The chargeable hours within each rate period determines the appropriate rate.
- (c) Determine the total usage charge by multiplying the hourly rate for the appropriate rate period by the number of chargeable hours in each rate period and then totaling these charges.
- (d) Add the monthly rate (per 800/888 number) to the total usage charge calculated above to obtain the total overall charge for Business/Residence Line 800 Service on a single 800/888 number.
- (e) Repeat steps 1 through 4 for each additional 800/888 number.
- (f) Rates for changes to existing Business/Residence Line 800 Service are found in Section 3 of this Product Guide, Subsequent Order Additions Charge.

4. Charges for Business/Residence Line 800 Service are determined on a per 800/888 number basis. Usage on separate 800/888 numbers may not be aggregated.

<sup>1</sup> Intrastate intraLATA Wide Area Telecommunications Service (WATS) is grandfathered and limited to existing customers at existing locations as of January 13, 2005.

<sup>2</sup> Effective November 3, 2012 moves, additions or changes to business subscribers' existing service are not permitted. Intrastate intraLATA Wide Area Telecommunications Service (WATS) continues to be available for resale until February 16, 2013, on which date the foregoing terms shall be effective for resale.

<sup>3</sup> Effective November 3, 2012, 800 Services are grandfathered and limited to existing business customers at existing locations. Moves, additions or changes to business subscribers' existing service are not permitted. 800 Services continue to be available for resale until February 16, 2013, on which date the foregoing terms shall be effective for resale.

<sup>4</sup> Effective November 16, 2013, Residence Line 800 Services is no longer available for purchase. Existing customers of record may retain these services at existing locations in accordance with the terms and conditions described herein. Service is not offered for new installations, moves, changes, or additions.

Effective: April 1, 2016

WIDE AREA TELECOMMUNICATIONS (WATS) AND 800 SERVICES <sup>1, 5, 6</sup>

IV. RATES AND CHARGES

A. WATS

1. Access Line	<u>Monthly Rate</u>
Access Line, each: <sup>5, 6, 7</sup>	
- Northern Cal. Half State	\$35.00
- Southern Cal. Half State	35.00
- Full State	35.00
- LATA	35.00

2. Usage Charges

Usage Charges apply to intraLATA outward calls placed over a WATS access line.

(a) Set-up Charge	<u>Charge</u>
- Per Message	\$.05

(b) The hourly rates apply to the average use of the access lines within a service group rounded to the nearest tenth of an hour. <sup>7</sup>

<u>Average Hours of Use</u>	<u>Rate Group</u>	<u>Rate</u>
0-5	1	\$5.30
15.1 - 30	3	4.60
Over 30	4	4.20

<sup>1</sup> Intrastate intraLATA Wide Area Telecommunications Service (WATS) is grandfathered and limited to existing customers at existing locations as of January 13, 2005.

<sup>2</sup> Service Charges for installation of a WATS access line are shown in Section 3 of this Product Guide.

<sup>3</sup> For Four Wire Terminating Arrangement option, see III.A.2.(z). preceding.

<sup>4</sup> For WATS access line service provided in conjunction with an Interexchange Carrier, see the Facilities for Intrastate Access Tariff C-1.

<sup>5</sup> Effective November 3, 2012 moves, additions or changes to business subscribers' existing service are not permitted. Intrastate intraLATA Wide Area Telecommunications Service (WATS) continues to be available for resale until February 16, 2013, on which date the foregoing terms shall be effective for resale.

<sup>6</sup> Effective November 3, 2012, 800 Services are grandfathered and limited to existing business customers at existing locations. Moves, additions or changes to business subscribers' existing service are not permitted. 800 Services continue to be available for resale until February 16, 2013, on which date the foregoing terms shall be effective for resale.

<sup>7</sup> See III.B.2.(d). preceding.

Effective: April 1, 2016

WIDE AREA TELECOMMUNICATIONS (WATS) AND 800 SERVICES <sup>4, 5, 6</sup>

IV. RATES AND CHARGES (Continued)

B. DEDICATED 800 SERVICE

800 Service served by the Company will be provided within the same LATA as the customer location.

1. Dedicated 800 Service Access Line	Monthly <u>Rate</u>
Access Line, each: <sup>1,2,3</sup>	
- Northern Cal. Half State	\$30.00
- Southern Cal. Half State	30.00
- Full State	30.00
- Metro	30.00

2. Usage Charges

Usage charges apply to intraLATA inward calls placed over a Dedicated 800 access line.

(a) Set Up Charge

	<u>Charge</u>
Per completed message on Metro	\$.05
- Per completed message on Northern Cal. - Half State, Southern Cal. – Half State, and Full State 800 bills with less than 100 hours of usage in a monthly billing period	.05
- Per completed message on Northern Cal. - Half State, Southern Cal. – Half State, and Full State 800 bills with a minimum of 100 hours of usage in a monthly billing period	None

<sup>1</sup> Service Order Charges as shown in Section 3 of this Product Guide are applicable for installation of a Dedicated 800 Service Access Line.

<sup>2</sup> For four wire terminating arrangement option see III.A.2.(z). preceding.

<sup>3</sup> For Dedicated 800 access line service provided in conjunction with an interexchange carrier, see the Facilities for Intrastate Access Tariff C-1.

<sup>4</sup> Intrastate intraLATA Wide Area Telecommunications Service (WATS) is grandfathered and limited to existing customers at existing locations as of January 13, 2005.

<sup>5</sup> Effective November 3, 2012 moves, additions or changes to business subscribers' existing service are not permitted. Intrastate intraLATA Wide Area Telecommunications Service (WATS) continues to be available for resale until February 16, 2013, on which date the foregoing terms shall be effective for resale.

<sup>6</sup> Effective November 3, 2012, 800 Services are grandfathered and limited to existing business customers at existing locations. Moves, additions or changes to business subscribers' existing service are not permitted. 800 Services continue to be available for resale until February 16, 2013, on which date the foregoing terms shall be effective for resale.

Effective: April 1, 2016

WIDE AREA TELECOMMUNICATIONS (WATS) AND 800 SERVICES <sup>4, 5, 6</sup>

IV. RATES AND CHARGES (Continued)

B. DEDICATED 800 SERVICE (Continued)

2. Usage Charges (Continued)

(b) Hours of Usage <sup>1</sup>

The hourly rate applies to the actual use of the access lines within a service group rounded to the nearest tenth of an hour <sup>2</sup>

Messages placed on any of the holidays listed in Section 28 of this Product Guide are rated in the discount period following.

	<u>Rate Period</u>
- Monday thru Friday, 9:00 a.m. to 9:00 p.m. <sup>3</sup>	1
- Discount Period, All Other Hours	2

	<u>Rate Period</u>	
	1	2
- Northern or Southern Cal. Half State		
- bills with less than 100 hours, Per hour	\$6.74	\$5.09
- bills with a minimum of 100 hours, Per hour	5.24	3.94
- Full State		
- bills with less than 100 hours, Per hour	6.74	5.09
- bills with a minimum of 100 hours, Per hour	5.24	3.94
- Metro, Per hour	6.74	5.09

<sup>1</sup> Charges for messages beginning in one time period and completing in the other time period are determined by applying the appropriate rate for the portion of the message occurring in each period.

<sup>2</sup> See III.C.2.(h). following.

<sup>3</sup> To, but not including.

<sup>4</sup> Intrastate intraLATA Wide Area Telecommunications Service (WATS) is grandfathered and limited to existing customers at existing locations as of January 13, 2005.

<sup>5</sup> Effective November 3, 2012 moves, additions or changes to business subscribers' existing service are not permitted. Intrastate intraLATA Wide Area Telecommunications Service (WATS) continues to be available for resale until February 16, 2013, on which date the foregoing terms shall be effective for resale.

<sup>6</sup> Effective November 3, 2012, 800 Services are grandfathered and limited to existing business customers at existing locations. Moves, additions or changes to business subscribers' existing service are not permitted. 800 Services continue to be available for resale until February 16, 2013, on which date the foregoing terms shall be effective for resale.



WIDE AREA TELECOMMUNICATIONS (WATS) AND 800 SERVICES <sup>3, 4, 5.</sup>

IV. RATES AND CHARGES (Continued)

C. BUSINESS/RESIDENCE LINE 800 SERVICE

	<u>Nonrecurring Charge</u> <sup>1</sup>	<u>Monthly Rate</u>
1. Business Line 800 Service		\$15.00
Month-to-Month	\$10.00	
One Year Agreement	5.00	
Two Year Agreement	3.00	
Three Year Agreement	0.00	
2. Residence Line 800 Service <sup>6</sup>		10.00
Month-to-Month	10.00	
One Year Agreement	5.00	
Two Year Agreement	3.00	
Three Year Agreement	0.00	
3. Optional Features		
Variable Call Destination- Rates per termination	-	5.00 <sup>2</sup>
<p>Variable Call Destination provides for multiple terminations, within one LATA of the 800/888 number assigned in conjunction with Business- Residence Line 800 Service.</p>		

<sup>1</sup> Nonrecurring charges as set forth in Section 3 of this Product Guide are applicable in lieu of the Business/Residence Line 800 nonrecurring charges when Business/Residence Line 800 Service is ordered by a customer requesting new telephone service. When Business/Residence Line 800 Service is added to existing service, only the nonrecurring charges for Business/Residence Line 800 are applicable, the charges in Section 3 of this Product Guide do not apply.

<sup>2</sup> Nonrecurring charges as set forth in Section 3 of this Product Guide apply when Variable Call Destination is added at a different time than Business/Residence Line 800 Service. There is no additional nonrecurring charge for Variable Call Destination when added at the same time as Business/Residence Line 800 Service.

<sup>3</sup> Intrastate intraLATA Wide Area Telecommunications Service (WATS) is grandfathered and limited to existing customers at existing locations as of January 13, 2005.

<sup>4</sup> Effective November 3, 2012 moves, additions or changes to business subscribers' existing service are not permitted. Intrastate intraLATA Wide Area Telecommunications Service (WATS) continues to be available for resale until February 16, 2013, on which date the foregoing terms shall be effective for resale.

<sup>5</sup> Effective November 3, 2012, 800 Services are grandfathered and limited to existing business customers at existing locations. Moves, additions or changes to business subscribers' existing service are not permitted. 800 Services continue to be available for resale until February 16, 2013, on which date the foregoing terms shall be effective for resale.

<sup>6</sup> Effective November 16, 2013, Residence Line 800 Services is no longer available for purchase. Existing customers of record may retain these services at existing locations in accordance with the terms and conditions described herein. Service is not offered for new installations, moves, changes, or additions.

Effective: April 1, 2016

WIDE AREA TELECOMMUNICATIONS (WATS) AND 800 SERVICES <sup>3, 4, 5</sup>

IV. RATES AND CHARGES (Continued)

C. BUSINESS/RESIDENCE LINE 800 SERVICE (Continued)

4. Usage - per hour

The hourly rate applies to the actual use of the 800/888 number rounded to the nearest tenth of an hour.

<u>Rate Periods</u>	<u>Hours</u>	<u>Rate Period</u>		
Monday thru Friday	8:00 am to 5:00 pm <sup>1</sup>	1		
	5:00 pm to 11:00 pm <sup>1</sup>	2		
	11:00 pm to 8:00 am	3		
Saturday, Sunday, and Holidays <sup>2</sup>	All	3		
		3		
		<u>Rate Periods</u>	<u>Per Hour</u>	
		<u>1</u>	<u>2</u>	<u>3</u>
(a) Month-to-Month				
- Less than 24.9 hours	\$8.10	\$7.25	\$6.45	
- Minimum 25 hours	7.35	6.60	5.90	
- Minimum 50 hours	7.00	6.30	5.60	
- Minimum 100 hours	6.60	5.95	5.30	
- Minimum 200 hours	6.25	5.60	5.00	
- Minimum 500 hours	5.90	5.30	5.00	
(b) One Year Contract				
- Less than 24.9 hours	7.80	7.00	6.35	
- Minimum 25 hours	7.05	6.35	5.80	
- Minimum 50 hours	6.70	6.05	5.50	
- Minimum 100 hours	6.20	5.70	5.20	
- Minimum 200 hours	5.85	5.35	4.90	
- Minimum 500 hours	5.50	5.05	4.90	

<sup>1</sup> To, but not including.

<sup>2</sup> See Section 16 of this Product Guide.

<sup>3</sup> Intrastate intraLATA Wide Area Telecommunications Service (WATS) is grandfathered and limited to existing customers at existing locations as of January 13, 2005.

<sup>4</sup> Effective November 3, 2012 moves, additions or changes to business subscribers' existing service are not permitted. Intrastate intraLATA Wide Area Telecommunications Service (WATS) continues to be available for resale until February 16, 2013, on which date the foregoing terms shall be effective for resale.

<sup>5</sup> Effective November 3, 2012, 800 Services are grandfathered and limited to existing business customers at existing locations. Moves, additions or changes to business subscribers' existing service are not permitted. 800 Services continue to be available for resale until February 16, 2013, on which date the foregoing terms shall be effective for resale.

Effective: April 1, 2016

WIDE AREA TELECOMMUNICATIONS (WATS) AND 800 SERVICES <sup>1,2,3</sup>

IV. RATES AND CHARGES (Continued)

C. BUSINESS/RESIDENCE LINE 800 SERVICE (Continued)

4. Usage - per hour (Continued)

		<u>Rate Periods</u>	
		<u>Per Hour</u>	
	<u>1</u>	<u>2</u>	<u>3</u>
(c) Two Year Contract			
- Less than 24.9 hours	\$7.65	\$6.95	\$6.15
- Minimum 25 hours	6.90	6.30	5.60
- Minimum 50 hours	6.55	6.00	5.30
- Minimum 100 hours	6.00	5.65	5.00
- Minimum 200 hours	5.65	5.30	4.70
- Minimum 500 hours	5.30	5.00	4.70
(d) Three Year Contract			
- Less than 24.9 hours	7.30	6.90	6.10
- Minimum 25 hours	6.55	6.25	5.55
- Minimum 50 hours	6.20	5.95	5.25
- Minimum 100 hours	5.70	5.60	4.95
- Minimum 200 hours	5.35	5.25	4.65
- Minimum 500 hours	5.00	4.95	4.65

<sup>1</sup> Intrastate intraLATA Wide Area Telecommunications Service (WATS) is grandfathered and limited to existing customers at existing locations as of January 13, 2005.

<sup>2</sup> Effective November 3, 2012 moves, additions or changes to business subscribers' existing service are not permitted. Intrastate intraLATA Wide Area Telecommunications Service (WATS) continues to be available for resale until February 16, 2013, on which date the foregoing terms shall be effective for resale.

<sup>3</sup> Effective November 3, 2012, 800 Services are grandfathered and limited to existing business customers at existing locations. Moves, additions or changes to business subscribers' existing service are not permitted. 800 Services continue to be available for resale until February 16, 2013, on which date the foregoing terms shall be effective for resale.

Effective: April 1, 2016

---

WIDE AREA TELECOMMUNICATIONS (WATS) AND 800 SERVICES <sup>1, 2, 3</sup>

IV. RATES AND CHARGES (Continued)

D. ANCILLARY SERVICES

1. Additional Terminations

- (a) When a WATS/800 access line terminates, it is designated as the access line. Any other terminations of the same access line are designated as additional terminations.
- (b) Additional terminations are provided only within the same LATA in which the access line terminates.
- (c) Rates and Charges - refer to the Facilities for Intrastate Access Tariff C-1.
  - (1) Special Access Lines (Additional line terminations)
  - (2) Special Transport and Special Transport Termination

2. Four-Wire Terminating Arrangements

- (a) Four-Wire Terminating Arrangements are used in connection with Wide Area Telecommunications Service.
- (b) The Four-Wire Terminating Arrangement permits terminating equipment that is designed to use four-wire terminations to be connected to the Company's services. While this offering contemplates the use of four-wire facilities, between the local serving central office and the premises terminating equipment, two-wire facilities may be used. Transmission performance that meets the established standards of the Company will be obtained over facilities connected to a Four-Wire Terminating Arrangement. If a customer requires additional special equipment for which provision is not included herein, additional installation charges and monthly rates will be incurred based upon the total cost of the equipment furnished or of the special work required, subject to the review of such charges by the Public Utilities Commission of the State of California.
- (c) Rates and Charges

The rates and charges following are for the Four-Wire Terminating Arrangement only and are in addition to the applicable rates and charges for the WATS 1/800 access line with which it is associated.

	Installation Charge <sup>4</sup>
- When installed coincident with the associated access line WATS Service	\$184.75
800 Service	179.08
- When installed subsequent to the associated WATS access line	82.46

<sup>1</sup> Intrastate intraLATA Wide Area Telecommunications Service (WATS) is grandfathered and limited to existing customers at existing locations as of January 13, 2005.

<sup>2</sup> Effective November 3, 2012 moves, additions or changes to business subscribers' existing service are not permitted. Intrastate intraLATA Wide Area Telecommunications Service (WATS) continues to be available for resale until February 16, 2013, on which date the foregoing terms shall be effective for resale.

<sup>3</sup> Effective November 3, 2012, 800 Services are grandfathered and limited to existing business customers at existing locations. Moves, additions or changes to business subscribers' existing service are not permitted. 800 Services continue to be available for resale until February 16, 2013, on which date the foregoing terms shall be effective for resale.

<sup>4</sup> In addition to any applicable Service Charges as set forth in Section 3 of this Product Guide (for example: Service Order Activity, Central Office Activity and/or Premise Visit - any or all of these charges may be applicable).

Effective: April 1, 2016

---

FACILITIES BASED SERVICES  
(LOCAL, INTRASTATE ACCESS AND INTRALATA TOLL)

TABLE OF CONTENTS

	<u>SHEET NO.</u>
I. GENERAL	
A. Applicability	1
B. Definitions	1
C. Maps	2
II. LIST OF SERVICES	
A. Local Services	3
B. Intrastate Access Services	4
C. IntraLATA Toll Services	4
III. TERMS AND CONDITIONS	5
IV. PROVISIONING	6
V. RATES AND CHARGES	
A. Local Services	33
B. Intrastate Access Services	51
C. IntraLATA Toll Services	77

Effective: April 1, 2016

---

FACILITIES BASED SERVICES  
(LOCAL, INTRASTATE ACCESS AND INTRALATA TOLL)

I. GENERAL

A. APPLICABILITY

This Product Guide schedule is applicable to areas in which Frontier, acting as a Competitive Local Exchange Carrier (CLEC) out of franchise, will provide Facilities Based Services (Local, Access and IntraLATA Toll) to customers as outlined in D. 95-07-054 and Limited Facilities Based Services to customers as outlined in D. 02-02-011. These areas are defined in the MAPS section (I.C) of this Product Guide.

Frontier Voice Mail, Voice Messaging Services and Message Manager are available to end users of a CLEC when the end user's service is provided on a resold line of Frontier. Service may be ordered by an end user or by a CLEC acting as the agent of the end user. See Section 5 of this Product Guide for descriptions, terms, conditions and rates.

B. DEFINITIONS

1. **Facilities Based Service Provider** - A provider of telecommunications services, within defined service areas, that directly owns, controls, operates, or manages conduits, ducts, poles, wires, cables, instruments, switches, appurtenances, or appliances in connection with, or to provide, local exchange communications within its defined service areas and between service areas of other local exchange providers within California. A facilities based service provider may own, control, operate, or manage conduits, ducts, poles, wires, cables, instruments, switches, appurtenances or appliances in only a part of its defined service area.
2. **Non-Facilities Based Resale Service Provider** - A provider of telecommunications services within defined service areas that does not directly own, control, operate, or manage conduits, ducts, poles, wires, cables, instruments, switches, appurtenances, or appliances in connection with, or to provide, local exchange communications within its defined service areas and between service areas of other local exchange providers within California.
3. **Optical Networking (SONET) Facilities**
  - a. **Central Office Node (CO Node)** - A central office that is equipped with a fiber optic terminal in which the customer requests the ability to add/drop traffic to a customer designated location (CDL).
  - b. **Mileage Calculation** - Mileage between Utilities' Points of Presence (POPs) where services are offered is calculated based on V&H coordinates reflected in NECA Tariff FCC No. 4.

The calculation of airline mileage between Company network terminal offices is performed as follows:

- (1) Obtain the V&H coordinates for each POP.
- (2) Obtain the difference between the V coordinates and between the H coordinates for each POP.
- (3) Square each difference from (2) above.
- (4) Add the square of the V difference to the square of the H difference from (3) above.
- (5) Divide the sum of the squared numbers by 10. Round to the next higher whole number.
- (6) Obtain the square root of the number obtained in (5) above. Round to the next higher whole number. This is the airline mileage figure.
- (7) If calculating quarter (1/4) miles, obtain the square root of the result obtained in (6) above. This is the rate distance in miles. Fractional miles are rounded to the next higher mile. The rate for each quarter mile is 25% of the rate per mile, rounded to the nearest cent.

Effective: April 1, 2016

---

FACILITIES BASED SERVICES  
(LOCAL, INTRASTATE ACCESS AND INTRALATA TOLL)

I. GENERAL (Continued)

B. DEFINITIONS (Continued)

3. **Optical Networking (SONET) Facilities** (Continued)

- c. **Network Downtime** - Network downtime is defined as the number of minutes from a customer-reported outage, not determined to be the fault of the customer, until the customer accepts a cleared outage report. Network downtime is calculated in minutes, and subtracted from total monthly minutes. Total monthly minutes are determined by multiplying the number of days in a month by 1,440. The percentage figure obtained by dividing the number of minutes of total network availability by the total monthly minutes is used to determine monthly network availability.

C. MAPS

1. Frontier California Inc. concurs in all of the Maps as filed as part of Southwestern Bell Communications (SBC) Network and Exchange Services tariff, Schedule Cal. P.U.C. No. A5.



Effective: April 1, 2016

---

FACILITIES BASED SERVICES  
(LOCAL, INTRASTATE ACCESS AND INTRALATA TOLL)

I. GENERAL (Continued)

C. MAPS (Continued)

2. Frontier concurs in all of the maps as filed as part of Roseville Telephone Company's tariff.

II. LIST OF SERVICES

Terms and conditions applicable to the services listed are set forth in the corresponding Tariff schedules or Product Guide sections as shown.

<u>Service</u>	<u>Terms and Conditions</u>
A. Local Services	
1. Local Usage	
a. Measured Rate Service	General Exchange Tariff, Schedule No. A-9
b. Zone Usage Measurement Service (ZUM)	Product Guide Section 5
2. ISDN	Product Guide Section 13
a. Basic Rate Interface (BRI)	
b. Primary Rate Interface (PRI)	
3. Digital Network Services	Product Guide Section 14
a. Digital Channel Service	
b. Customer Network Control	
4. Centrex Service	Product Guide Section 11
5. Custom Calling Service	Product Guide Section 7
6. Discount Calling Plans	Product Guide Section 19
a. Flat Rate Calling Plan	
b. 5 Cents Plan (Plan M)	
c. Regional Toll Call Plan - Business	
d. Corporate Rewards	
e. Calling Solutions	
f. Flat Rate Business Calling Plus Savings Plan- Business	
7. Service Provider Number Portability (SPNP) Service	General Exchange Tariff, Schedule No. K-3
8. Local Network Interconnection	Individual Case Basis (ICB)
9. Directory Services	Product Guide Section 21
10. Inside Wire, Intra-building Network Cable (INC), Network Facilities and Associated Demarcation Points	Product Guide Section 19



Effective: March 1, 2018

---

FACILITIES BASED SERVICES  
(LOCAL, INTRASTATE ACCESS AND INTRALATA TOLL)

II. LIST OF SERVICES (Continued)

<u>Service</u>	<u>Terms and Conditions</u>
A. Local Services (Continued)	
11. Advanced Data Services	Product Guide Section 15
a. Videoconnect	
b. Asynchronous Transfer Mode (ATM) Cell Relay Service (CRS)	
c. Frame Relay Service	Product Guide Sections 15 and 32
d. Dedicated Sonet Ring (DSR)	
e. Dedicated Wave Length Ring (DWR)	
f. INTEGRATED OPTICAL SERVICES (IOS)	
g. Transparent Lan Service (TLS)	
h. Custom Connect Service	
B. Intrastate Access Services	
1. High Capacity Facilities	Facilities for Intrastate Access Tariff C-1
a. Digital DS1	
b. Fractional T1 (FT1)	
c. Digital DS3	
d. Digital DS3C	
C. IntraLATA Toll Services	
1. IntraLata Toll Service	Product Guide Section 28
a. Rate Schedules	
(1) Business and Residence	
(2) Operator Handled	
(3) Corrections Collect	
(4) Coin Station	
b. Operator Handled Service Charges	Product Guide Section 20
(1) Operator Handled Station-to-Station Service (Direct Dialed)	
(2) Operator Handled Station-to-Station Service (Coin)	
(3) Operator Handled Station-to-Station Service (Corrections Collect)	
(4) Operator Handled Person-to-Person Service (Direct Dialed)	
(5) Operator Handled Person-to-Person Service (Coin)	
(6) Pay Station Service Charge	
(7) Basic Number Referral Services	
2. Discount Calling Plans	Product Guide Section 19
a. Discount Calling Plan One	
b. Residence Direct Discount Plan	
c. Calling Solutions	
d. Regional Toll Call Plan - Business	

(D)  
(T)

Effective: April 1, 2016

---

FACILITIES BASED SERVICES  
(LOCAL, INTRASTATE ACCESS AND INTRALATA TOLL)

III. TERMS AND CONDITIONS

Terms and conditions applicable to the individual service offerings found in this Product Guide are set forth in the corresponding tariff schedules or Product Guide sections specified for each service as reflected in Section II, List of Services. Corresponding tariffs and Product Guide also identify where service connection charges from Section 3 of this Product Guide are applicable.

A. D&R Applications

In addition to the terms and conditions applicable to individual service offerings, all terms and conditions relating to Frontier service, such as disputed bill procedure, deposit policies, and procedures for termination service (as described in the General Exchange Tariff, Schedule No. D&R and Section 2 of this Product Guide), are also applicable, with the following exceptions:

1. **Deposit Refunds** - The requirements as described on the back of the deposit receipt are waived for customers receiving service under this Product Guide. Deposits will be refunded, with interest (see III.A.3, below), within 30 days after discontinuance of service or after 12 months of service, whichever comes first.
2. **Deposits** - Additional deposits as described in the General Exchange Tariff, Schedule D&R, Rule No. 6, are not required from customers under this Product Guide that owe a balance to a previously serving Utility. For customers receiving service under this Product Guide, Frontier will not refuse a deposit to establish credit for service. Deposits shall be no greater than twice the estimated average monthly bill for the class of service applied for.
3. **Interest** - The calculation of interest for deposits as described in the General Exchange Tariff, Schedule No. D&R, Rule No. 7, will be calculated using the 3-month commercial paper rate published by the Federal Reserve Board. No interest shall be given if the customer has received a minimum of two discontinuance of service notices in a 12-month period.
4. **Application for Service** - Frontier shall, on request, provide each applicant for service or customer under this Product Guide schedule the following:
  - a. The CPUC identification number of its registration to operate as a telecommunications corporation within California.
  - b. The address and telephone number of the CPUC to verify its authority to operate.
  - c. A copy of the Consumer Protection Regulations as set forth in D.95-07-054.
  - d. A toll-free number to call for service or billing inquiries, along with an address where the customer may write Frontier.
  - e. A full disclosure of all fictitious (i.e., "DBA") names.
  - f. The names of billing agents it uses in place of performing the billing function itself.
  - g. Rate information as required by D.95-07-054, Rule 6(A).

B. Facilities Based Services are available where technically feasible.

Effective: April 1, 2016

---

FACILITIES BASED SERVICES  
(LOCAL, INTRASTATE ACCESS AND INTRALATA TOLL)

III. TERMS AND CONDITIONS (Continued)

- C. Solicitations by Frontier, or its agents, of customer authorization for termination of service with an existing carrier and the subsequent transfer to Frontier will include current rate information on Frontier and information regarding the terms and conditions of the service with Frontier and will conform with PU Code, Section 2889.5.
- D. Frontier is liable for both the unauthorized termination of service and the subsequent unauthorized transfer to its service. Frontier is responsible for the actions of its agents that solicit unauthorized service termination and transfers. In the instance of such unauthorized solicitation, Frontier will:
  - 1. restore the end user's service without charge;
  - 2. refund all billings during the unauthorized service period to the end user; and
  - 3. provide reimbursement for reestablishing service at the Product Guide rate of the authorized Company.
- E. All intrastate end user telecommunications services provided by certificated telecommunications companies will be subject to surcharges for programs required by statute. Programs for which surcharges will apply include:

Program

Universal Lifeline Telephone Service  
California Relay Services and Communication Devices Fund  
Public Utilities Commission Reimbursement Fee  
California High Cost Fund A  
California High Cost Fund B  
California Teleconnect Fund

IV. PROVISIONING

A. Intrastate Access Services

1. Optical Networking (SONET) Facilities

a. General

This section contains the terms and conditions pertaining to the provisioning of SONET Service. The rates, terms and conditions specified herein are in addition to the applicable rates, terms and conditions specified in other sections of this Product Guide and other Company tariffs.

This service supports asynchronous bandwidth capacities at 1.5 Mbps and 45 Mbps in addition to synchronous Optical Carrier (OC) bandwidth capacities at OC-3 and OC-12 Mbps. The SONET add/drop multiplexer aggregates lesser bit speed services onto the dedicated SONET ring or the two-point SONET circuit configuration.

The customer is responsible for providing all facilities and cabling necessary to connect customer equipment to this interface.

Effective: April 1, 2016

---

FACILITIES BASED SERVICES  
(LOCAL, INTRASTATE ACCESS AND INTRALATA TOLL)

IV. PROVISIONING (Continued)

A. Intrastate Access Services (Continued)

1. Optical Networking (SONET) Facilities (Continued)

a. General (Continued)

Customer Facility Assignment (CFA) is controlled by the Company, in all access customer serving wire centers on the Interoffice Facility (IOF) and extends to the terminating CDL. Should the customer require control of the facility assignment and order multiplexing on the IOF, the services from the multiplexer to the end user serving wire center will be ordered from V. Rates and Charges B.2.b following.

It is the customer's responsibility to ensure that the customer's equipment provides industry standard electrical signals compatible with Optical Networking transport transmission. Technical specifications are contained in the following publications:

Bellcore Document GR-253-CORE, Issue 2, April, 1996  
Bellcore Document GR-1400-CORE, Issue 1, March, 1994  
Bellcore Document GT-1374-CORE, Issue 1, March, 1994  
American National Standard, ANSI T1.105-1996  
American National Standard, ANSI T1.102-1993

The Company will work cooperatively with the customer during a planning session to insure that the customer orders sufficient Optical Networking bandwidth capacity to satisfy the customer's requirements as well as other applicable Optical Networking services. This planning session must take place prior to the customer's placement of an initial Optical Networking service order.

b. Availability of Service

Service is available where technically feasible and is limited to within 1/2-mile of existing facilities and the 1/2-mile limit may not be in addition to any other 1/2-mile addition to existing facilities.

c. Service Credit

Customers will receive a credit for network downtime (as specified in I. General B.3.c.) greater than 30 minutes.

d. Description

Optical Networking is comprised of high speed SONET based technology providing connectivity at, and transport between, two or more CDLs.

Effective: April 1, 2016

---

FACILITIES BASED SERVICES  
(LOCAL, INTRASTATE ACCESS AND INTRALATA TOLL)

IV. PROVISIONING (Continued)

A. Intrastate Access Services (Continued)

1. Optical Networking (SONET) Facilities (Continued)

e. Service Elements

(1) Connect

The Connect service element provides the platform for customer access to the Company's Optical Network which provides the link between the CDL and the service wire center of the CDL.

There are two types of Connect:

(a) Custom Connect

Custom Connect provides a connection between the Company's Optical Network and an access customer's CDL. Custom Connect is comprised of four service elements: Central Office (CO) Nodes, CDL Links, Transport and Riders. Each Custom Connect must consist of a minimum of two CDLs, one of which must be a CDL Link.

1) Central Office (CO) Node

A CO Node is defined as each central office equipped with a fiber optic terminal in which the customer requests the ability to add/drop traffic to a CDL. If the customer wants to drop traffic below a DS3 at the CO Node, the customer must request a minimum DS1 interface and appropriate special access lines from V.B.2.a. The appropriate multiplexing and access lines and transport rates from V.B.2.b will apply in addition to the CO Node and appropriate rider charges. The CO Node may be ordered at an OC3 or OC12 bandwidth capacity. The CO Node may be ordered for a one year, three year, five year, or seven year term period.

A CO Node may be ordered when a customer requires OC level multiplexing on the Custom Connect service element.

CO Nodes may only be ordered from wire centers with Optical Networking capabilities.

Effective: April 1, 2016

---

FACILITIES BASED SERVICES  
(LOCAL, INTRASTATE ACCESS AND INTRALATA TOLL)

IV. PROVISIONING (Continued)

A. Intrastate Access Services (Continued)

1. Optical Networking (SONET) Facilities (Continued)

e. Service Elements (Continued)

(1) Connect (Continued)

(a) Custom Connect (Continued)

2) CDL Link

The CDL Link service element is defined as a route to each CDL to which the customer requests the ability to add/drop traffic. The CDL Link is offered as a Single Route, Diverse Route, or Ring Route and may be ordered with or without Company provided electronics as OC3 or OC12 bandwidth capacity. Only one CDL Link per Custom Connect may be ordered without electronics.

If more than two CDL Links or CO Nodes are ordered on the same order, the CDL Link may be ordered as a Ring Route CDL Link. A Custom Connect ordered via a ring topology will be provided with an out-of-service credit as specified in IV.A.1.c.

The CDL Link may be ordered as OC3c<sup>1</sup> or OC12c Single Route or Diverse Route with Company provided electronics. OC3c and OC12c rider charges are included in the monthly rate for OC3c and OC12c CDL Links.

The CDL Link may be ordered under a one year, three year, five year, or seven year term period.

3) CDL Link with Optical Cross Connect

The CDL Link with Optical Cross Connect provides the communications path between the Company's serving wire center end of a CDL Link and an IXC's or ISP's transmission equipment and facilities collocated in the Company's serving wire center. This service element includes the CDL Link from the fiber optic terminal and the optical jumpers that facilitate the cross connect to the IXC's or ISP's transmission equipment and facilities, located within the Company wire center.

The CDL Link with Optical Cross Connect will be provided as a single route without Company provided electronics as OC3, OC3c, OC12 or OC12c as ordered by the customer.

<sup>1</sup> "c" is defined as Concatenated and denotes the linking together of various data structures; e.g., two bandwidths joined to form a single bandwidth.

Effective: April 1, 2016

---

FACILITIES BASED SERVICES  
(LOCAL, INTRASTATE ACCESS AND INTRALATA TOLL)

IV. PROVISIONING (Continued)

A. Intrastate Access Services (Continued)

1. Optical Networking (SONET) Facilities (Continued)

e. Service Elements (Continued)

(1) Connect (Continued)

(a) Custom Connect (Continued)

3) CDL Link with Optical Cross Connect (Continued)

In addition to the rate for the CDL Link with Optical Cross Connect, the appropriate CDL Link rate is applicable from the CDL to the serving wire center, and the appropriate Dedicated Transport rate is applicable between serving wire centers.

The CDL Link with Optical Cross Connect may be ordered as a one year, three year, five year, or seven year term period.

Rates for the CDL Link with Optical Cross Connect are shown in V.B.2.c.(5).(a) will apply in addition to other charges specified in this section.

4) Transport

Transport may be ordered as shared or dedicated transport. Shared Transport is transport between CO Nodes or between CO Nodes and Links ordered at different bandwidth levels. Dedicated Transport is transport between CO Nodes or between CO Nodes and Links of the same bandwidth level. Shared Transport may be ordered in bandwidths of DS1, DS3/STS1, OC3, OC3c, OC12 or OC12c. Dedicated Transport may be ordered in bandwidths of OC3, OC3c, OC12 or OC12c.

Transport is mileage sensitive and will be calculated based on the V&H coordinates of the wire centers comprising each segment of the connection. The mileage calculation is specified in I.B.3.b.

Transport is provided at a monthly recurring charge, per airline mile.

5) Rider

A Rider provides specified bandwidth level for the customer's service(s) traversing the CDL Link. Riders may be provided at DS1, DS3, OC3c, OC12c, or STS1 bandwidth levels as required by the customer.

A Rider is provided at a flat-rated monthly recurring charge which includes add/drop multiplexing and is applicable per rider circuit with the exception of OC3c and OC12c CDL Links.

Effective: April 1, 2016

---

FACILITIES BASED SERVICES  
(LOCAL, INTRASTATE ACCESS AND INTRALATA TOLL)

IV. PROVISIONING (Continued)

A. Intrastate Access Services (Continued)

1. Optical Networking (SONET) Facilities (Continued)

e. Service Elements (Continued)

(1) Connect (Continued)

(b) Express Connect

Express Connect service provides a connection to the Company's Optical Networking wire center(s) via a ring topology consisting of three nodes, one of which must be a Company wire center. When two of the nodes are CDLs, at least one of the CO Nodes must be electrical. Express Connect is provided at a bandwidth of OC3 or OC12 and may be ordered for a one year, three year, five year, or seven year term period.

Express Connect is comprised of five service elements: a First System, Additional System(s), Additional CDL Nodes, Additional CO Nodes and Transport.

1) First System

The customer may order the "First System" of OC3 or OC12 bandwidth.

2) Additional System

The customer may order up to three "Additional Systems" of OC3 or OC12 bandwidth, not to exceed OC12 or OC48 bandwidth capacity respectively.

3) Additional CDL Node

The Additional CDL Node service element is each CDL to which the customer requests the ability to add/drop traffic. The Additional CDL Node may be ordered at an OC3 or OC12 bandwidth capacity.

4) Additional CO Node

The Additional CO Node service element is each central office equipped with a fiber optic terminal in which the customer requests the ability to add/drop traffic to a CDL. If the customer wants to drop traffic below a DS3 at the CO Node, the customer must request a minimum DS1 interface and appropriate special access lines from V.B.2.a. The appropriate multiplexing and access lines and transport rates from V.B.2.a and V.B.2.b will apply in addition to the Additional CO Node charge. The Additional CO Node may be ordered at an OC3 or OC12 bandwidth capacity.



Effective: April 1, 2016

---

FACILITIES BASED SERVICES  
(LOCAL, INTRASTATE ACCESS AND INTRALATA TOLL)

IV. PROVISIONING (Continued)

A. Intrastate Access Services (Continued)

1. Optical Networking (SONET) Facilities (Continued)

e. Service Elements (Continued)

(1) Connect (Continued)

(b) Express Connect (Continued)

5) Transport

Transport may be ordered as shared or dedicated. Shared Transport is transport between CO Nodes or between CO Nodes and Links ordered at different bandwidth levels. Dedicated Transport is transport between CO Nodes or between CO Nodes and Links of the same bandwidth level. Shared Transport may be ordered in bandwidths of DS1, DS3/STS1, OC3, OC3c, OC12 or OC12c. Dedicated Transport may be ordered in bandwidths of OC3, OC3c, OC12 or OC12c.

Transport is mileage sensitive and will be calculated based on the V&H coordinates of the wire centers comprising each segment of the connection. The mileage calculation is specified in I.B.3.b.

Transport is provided at a monthly recurring charge, per airline mile (see V.B.2).

The Transport service element applies when Express Connect has more than one CO Node in the ring. The appropriate Custom Connect Shared Transport rates from V.B.2.c.(7) will apply in addition to all other Express Connect rates.

6) Rider

A Rider provides specified bandwidth level for the customer's service(s) traversing the CDL Link. Riders may be provided at DS1, DS3, OC3c, OC12c, or STS1 bandwidth levels as required by the customer.

A Rider is provided at a flat-rated monthly recurring charge which includes add/drop multiplexing and is applicable per rider circuit with the exception of OC3c and OC12c CDL Links.

Rider charges are included in the monthly rates for Express Connect First or Additional Systems.

Effective: April 1, 2016

---

FACILITIES BASED SERVICES  
(LOCAL, INTRASTATE ACCESS AND INTRALATA TOLL)

IV. PROVISIONING (Continued)

A. Intrastate Access Services (Continued)

1. Optical Networking (SONET) Facilities (Continued)

f. Rate Terms and Conditions

(1) General

Optical Networking may be ordered under a one year, three year, five year, or seven year term period. Any term commitment for these services is subject to the Termination Liability Charge.

When ordered together, the term commitment applies to Connects and Additional Nodes.

(2) Termination Liability

See Section 2 of this Product Guide for termination liability terms and conditions.

g. Off-Net Wire Center

Off-Net wire center is a wire center not designated as an Optical Networking wire center office. The customer may order a DS1 or DS3 to the Off-Net wire center. Associated transport mileage charges will be determined based on airline miles to the nearest On-Net wire center at the transport rates.

Circuits connected to the Off-Net wire center will be billed at existing Product Guide rates.

2. TRANSPARENT LAN SERVICE (TLS)

a. Definitions

In addition to definitions set forth else where in this Product Guide, the following definitions apply:

Domain - a Virtual Local Area Network (VLAN) or a collection of circuits that belong to one closed user group.

Gigabit Per Second (Gbps.) - the speed where data is being transferred in the network, where one Gigabit per second equals to the transfer rate of 1 billion bits of data in 1 second.

Megabit Per Second (Mbps.) - the speed of data being transferred in the network, where one Megabit Per Second equals to the transfer rate of 1 million bits of data in 1 second.

Nanometers (nm) - wavelength frequency equivalent to 1 billionth of a meter.

Effective: April 1, 2016

---

FACILITIES BASED SERVICES  
(LOCAL, INTRASTATE ACCESS AND INTRALATA TOLL)

IV. PROVISIONING (Continued)

A. Intrastate Access Services (Continued)

2. TRANSPARENT LAN SERVICE (TLS) (Continued)

b. Description

Transparent LAN Service (TLS) is a high speed data service which uses a shared fiber network to allow for the interconnection of Local Area Networks (LANs) across selected metropolitan areas in the same Local Access Transport Area (LATA).

TLS delivers an interface of 10 Mbps, 100 Mbps, 1000 Mbps and 10 Gbps from the customer's LAN to the shared network. TLS creates a network with the ability to function as a shared public network, and protects shared data privacy by using specialized screening software that permits subscribers to access only their data.

TLS is available in two service types: Ethernet Multipoint Service (EMS) or Ethernet Relay Service (ERS). The customer must select either (EMS) or (ERS) as the service type for each domain:

**Ethernet Multipoint Service (EMS)** - a connection-less Ethernet TLS service that allows connectivity among multiple customer designated locations within a LATA.

With the EMS service type, Ethernet TLS protects data privacy by using closed user groups (CUGs), also known as virtual LANs. CUGs or virtual LANs are used to provide traffic separation, privacy and security between customers on the shared switch and backbone. Subscribers in a CUG can only access their own data. An EMS domain is comprised of any number of access lines designated by the customer to be included in a closed user group (CUG) or virtual LAN. EMS provides multipoint-to-multipoint connectivity among all of the customer's access lines within a given domain. TLS may be used to access shared networks. In such cases, subscribers in a CUG can only access their own data.

**Ethernet Relay Service (ERS)** - a connection-oriented Ethernet TLS service that allows for point-to-point connectivity between customer designated locations within a LATA.

With the ERS service type, an Ethernet Virtual Circuit (EVC) establishes a virtual LAN or CUG. An ERS domain is comprised of any number of virtual LANs designated by the customer to be included in the ERS Standard domain. ERS provides point-to-point connectivity between pairs of customer's access lines and shared network services within a given domain.

A customer may have more than one domain within a LATA, but connections between domains are not permitted. TLS may be used to access shared networks. In such cases, subscribers in a CUG can only access their own data.

With ERS service type, an Ethernet Virtual Private – Local Area Network (EVP-LAN) can be established with EVP-LAN EVCs. An EVP-LAN is a multipoint Virtual LAN comprised of a CUG of two or more EVCs. EVP-LAN EVCs are designated by the Customer within an ERS Premier domain.

Effective: April 1, 2016

---

FACILITIES BASED SERVICES  
(LOCAL, INTRASTATE ACCESS AND INTRALATA TOLL)

IV. PROVISIONING (Continued)

A. Intrastate Access Services (Continued)

2. TRANSPARENT LAN SERVICE (TLS) (Continued)

b. Description (Continued)

Six EVC service classes are available for use with the ERS service type:

ERS Standard (ERS-Std), ERS Basic (ERS-B) and EVP-LAN Basic (EVPLAN-B) are designed for customer applications that do not require a Committed Information Rate (CIR) or low delay, where CIR = 0 and Excess Information Rate (EIR) = # of Mbps of the selected ERS-Std/ERS-B or EVPLAN-B EVC service class.

ERS-Priority Data (ERS-PD) is designed for customer applications which do not require low delay, but require a CIR, where CIR = # of Mbps of the selected ERS-PD EVC service class and EIR = # of Mbps of the selected ERS-PD EVC service class.

ERS Real Time (ERS-RT) and EVP-LAN Real Time (EVPLAN-RT) are designed for customer applications which require a CIR and low delay for some portion of their traffic, where CIR = # of Mbps of the selected ERS-RT or EVPLAN-RT EVC service class and EIR = 0. EVPLAN-RT is not available for 10 Gbps UNI Speed.

An ERS EVC can include up to three service classes (ERS-B, ERS-PD and ERS-RT) as described above within each EVC. An EVP-LAN EVC can include one service class (either EVPLAN-B or EVPLAN-RT) as described above within each EVC. The customer will be required to identify the Basic, PD and RT Class of Service Ethernet frames by one of the following choices:

- setting the VLAN Class of Service (CoS) ID (for 802.1q tagged Ethernet Frames); or
- setting the DiffServ Code Point (DSCP) (for tagged or untagged Ethernet frames); or
- setting the VLAN ID (for tagged or untagged Ethernet frames), appropriately.

c. Special Conditions

- (1) A TLS network will be limited to central offices in a specific geographic location. Customers gain access to the shared TLS network via a switch, node or other Company equipment delivering service through a shared fiber path or network infra-structure and deployed in the customer's serving central office (TLS equipped central office) deployed in leased space near the Customer's location, or deployed at the Customer's location. At subscription, the Customer has an option of selecting access lines at speeds of 10 Mbps, 100 Mbps, 1000 Mbps or 10 Gbps.
- (2) TLS is available to Customers whose serving central office is a TLS equipped central office and when the customer is located within the maximum allowable range of the serving central office. The maximum allowable fiber range is determined by the dB loss rate, so the actual distance between the TLS equipped central office and the customer's location may vary due to facility used in each serving arrangement.

Effective: April 1, 2016

---

FACILITIES BASED SERVICES  
(LOCAL, INTRASTATE ACCESS AND INTRALATA TOLL)

IV. PROVISIONING (Continued)

A. Intrastate Access Services (Continued)

2. TRANSPARENT LAN SERVICE (TLS) (Continued)

c. Special Conditions (Conditions)

- (3) If the Customer's serving central office is not a TLS equipped central office, the Customer may obtain service by paying the Interoffice Mileage charge in addition to TLS changes. The dB loss cannot exceed the maximum allowable range.
- (4) The standard Customer connectivity model for UNI Port and Access includes direct fiber or existing transport facilities between the Customer's location and the TLS equipped central office. Customers requesting Protected Access Line service will have two standby fibers provisioned in addition to the primary direct fiber. Customer may select to have their UNI Port and Access provisioned over an optical transport system. If so, the customer must choose one of the following UNI Port with Access arrangements:
  - Protected Non-Diverse: Customer connectivity is provisioned over an optical transport system as a survivable service with an alternate (non diverse) facility between the Customer's location and the TLS equipped central office. The optical protected interoffice charge is applicable to 1000 Mbps speed when interoffice facilities are required.
  - Protected Diverse: Customer connectivity is provisioned over an optical transport system as a survivable service with an alternate and diverse fiber path between the Customer's location and the TLS equipped central office. The optical protected interoffice charge is applicable to 1000 Mbps speed when interoffice facilities are required. Dual entrance at the customer premises and company wire centers are not considered a standard feature of this option, but may be provided through special construction charges, where facilities are available.
  - Protected Private: Customer connectivity is provisioned over a dedicated private ring which the customer has already obtained from the Telephone Company. At least one node of the private ring must be located in a TLS equipped central office.

Effective: April 1, 2016

---

FACILITIES BASED SERVICES  
(LOCAL, INTRASTATE ACCESS AND INTRALATA TOLL)

IV. PROVISIONING (Continued)

A. Intrastate Access Services (Continued)

2. TRANSPARENT LAN SERVICE (TLS) (Continued)

c. Special Conditions (Conditions)

(5) Provision of Service

TLS service consists of the following components:

- Network Interface Device (NID) at the customer's premises to terminate the fiber pair, or other optical transport.
- Optical Transport from the customer's premises to the serving central office.
- Network management including fault monitoring and diagnostics, performance and network configuration applications and manual monitoring when necessary.
- User Network Interface (UNI) Port with Access Line Connection.
- Ethernet Virtual Circuit (EVC), where applicable.
- Optional Features
- Customer Service Management (CSM) <sup>1</sup>
- Dedicated port on the switch.
- Interoffice Mileage, where applicable

(6) Availability of Service

TLS will be provided seven days a week, 24 hours a day, from Frontier central offices equipped to provide this service and where optical transport facilities exist.

ERS Service, including Premier Access Lines and ERS-Std, ERS-B, ERS-PD, ERS-RT, EVPLAN-B and EVPLAN-RT EVCs, as defined in section IV.A.2.b., will only be available from Central Offices equipped to support ERS service.

TLS is available where facilities and conditions permit. Special construction charges as referenced in this Product Guide may apply.

<sup>1</sup> Effective February 7, 2011 CSM is grandfathered and no longer available to new Customers. Moves, additions or changes to subscribers' existing service will not be permitted.

Effective: April 1, 2016

---

FACILITIES BASED SERVICES  
(LOCAL, INTRASTATE ACCESS AND INTRALATA TOLL)

IV. PROVISIONING (Continued)

A. Intrastate Access Services (Continued)

2. TRANSPARENT LAN SERVICE (TLS) (Continued)

c. Special Conditions (Conditions)

(7) Connections

The network interface device (NID) is the LAN interface on the TLS equipment at the customer's premises. The interfaces are as follows: 10 Mbps Ethernet RJ45,, 100 Mbps Ethernet RJ45, 1000 Mbps or 10,000 Mbps Ethernet multi-mode optical Connector.

The customer is responsible for any inside wire required in connecting the LAN to the TLS equipment.

The customer is also responsible for the installation, operation and maintenance of any customer-provided equipment.

The Company has the service responsibility up to and including the network interface device (NID).

(8) Limitations

The Customer's location must be within the maximum allowable range of the TLS equipped central office.

(9) Maintenance Window

To meet the customer's requirements, occasional network upgrades must be performed. These network upgrades are needed to provide improved performance and new features. Generally these upgrades will be performed between the hours of 11:00 PM and 6:00 AM. Network upgrades are planned to provide customers reasonable and timely notification in order to minimize any impact on the customer's service.

(10) Technical Specifications

The technical specifications for TLS are delineated in IEEE802.3-2000.

(11) Transmission Mode

The transmission mode supported is dependent on the access rate. The supported transmission mode for 10 Mbps access is half duplex and full duplex. Full duplex 10 Mbps access is available only where conditions and facilities permit. The supported transmission mode for 100 Mbps access, 1000 Mbps, or 10 Gbps.

Effective: April 1, 2016

---

FACILITIES BASED SERVICES  
(LOCAL, INTRASTATE ACCESS AND INTRALATA TOLL)

IV. PROVISIONING (Continued)

A. Intrastate Access Services (Continued)

2. TRANSPARENT LAN SERVICE (TLS) (Continued)

d. Application of Rates and Charges

(1) The following rate elements are applicable to TLS:

- UNI Port with Access Line Connection
- Domain/LAN Extension Equipment Changes
- Ethernet Virtual Circuit (EVC)
- Interoffice Mileage
- Optional Features
- Customer Service Management (CSM) <sup>1</sup>

(a) UNI Port with Access Line Connection

A monthly rate applies on a per line basis based on the speed of the access connection (i.e., 10 Mbps, 100 Mbps, 1000 Mbps or 10 Gbps). A nonrecurring charge will apply for the installation of the TLS Access Line when a customer subscribes to the Month-to-Month Option. The Access Line is offered as a Month-to-Month Option, or as a 3 or 5 Year Term Commitment Plan.

i. Standard Access Line (available for EMS or ERS Service Type)

A monthly rate applies on a per line basis, based on the speed of the access connection (i.e. 10 MBPS, 100 MBPS, 1000 MBPS or 10Gbps). The Standard Access Line is offered on a Month-to-Month basis, or as a 3 or 5 Year Term Commitment Plan. A nonrecurring charge applies to the installation of Standard Access Lines provided on a Month-to-Month basis. Besides the standard connectivity model, Standard Access Lines is offered with three other type of UNI Port with Access Line Connections, where facilities exist. (10 Gbps is not available for these Protected options.)

- (1) Protected Non-Diverse
- (2) Protected Diverse
- (3) Protected Private

ii. Protected Access Line (available for EMS Service Type) <sup>2</sup>

Protected Access Lines are provisioned as a survivable service with an alternate fiber pair between the central office and the customer premises. Protected Access Line allows the Company to recover from a detected failure by moving the customer's data to an alternate fiber pair in less than one second. Both fiber pairs must be served by the same central office and must have the same access speed. The second fiber pair will be routed over a diverse fiber path when possible.

<sup>1</sup> Effective February 7, 2011 CSM will no longer be available to new customers.

<sup>2</sup> Effective November 19, 2010, this service will no longer be available to new customers.



Effective: April 1, 2016

---

FACILITIES BASED SERVICES  
(LOCAL, INTRASTATE ACCESS AND INTRALATA TOLL)

IV. PROVISIONING (Continued)

A. Intrastate Access Services (Continued)

2. TRANSPARENT LAN SERVICE (TLS) (Continued)

d. Application of Rates and Charges (Continued)

(1) The following rate elements are applicable to TLS: (Continued)

(a) UNI Port with Access Line Connection (Continued)

ii. Protected Access Line (available for EMS Service Type) <sup>1</sup> (Continued)

A monthly rate applies on a per line basis, based on the speed of the access connection (i.e. 10 Mbps, 100 Mbps or 1000 Mbps). The Protected Access Line is offered on a Month-to-Month Option, or as a 3 or 5 Year Term Commitment Plan. Protected Access Line is only offered with a direct fiber UNI Port with Access Line Connection, where facilities exist. A nonrecurring charge will apply to the installation of a Protected Access Line provided on a Month-to-Month basis.

iii. Premier Access Line (available for ERS Service Type only)

A monthly rate applies on a per-line basis, based on the speed of the access line (i.e., 10 Mbps, 100 Mbps, 1000 Mbps). A Premier Access Line must be purchased in conjunction with some combination of ERS-B, ERS-PD, and/or ERS-RT, EVPLAN-B and/or EVPL-RT EVC service classes, which are described in section IV.A.2.b. The Premier Access Line is offered on a Month-to-Month basis or as a 3 or 5 Year Term Commitment Plan. A nonrecurring charge applies to the installation of the UNI provided on a Month-to-Month basis. A customer cannot mix Premier UNI Ports with any other UNI port type.

The percentage of each Premier Access Line UNIs allowed for EVC bandwidth is limited, where connections must comply with each of the following threshold requirements:

ERS-B less than or = 500% of UNI Speed  
ERS-PD less than or = 100% of UNI Speed  
ERS-RT less than or = 100% of UNI Speed  
ERS-PD + ERS-RT less than or = 100% of UNI Speed  
ERS-B + ERS-PD + ERS-RT less than or = 500% of UNI Speed  
EVPLAN-B less than or = 20 Gbps of the EVP-LAN CUG  
EVPLAN-RT less than or = 1 Gbps of the EVP-LAN CUG

Besides the standard connectivity model, Premier Access Line is offered with three other type of UNI Port with Access Line Connections, where facilities exist.

- (1) Protected Non-Diverse
- (2) Protected Diverse
- (3) Protected Private

<sup>1</sup> Effective November 19, 2010, this service will no longer be available to new customers.

Effective: April 1, 2016

---

FACILITIES BASED SERVICES  
(LOCAL, INTRASTATE ACCESS AND INTRALATA TOLL)

IV. PROVISIONING (Continued)

A. Intrastate Access Services (Continued)

2. TRANSPARENT LAN SERVICE (TLS) (Continued)

d. Application of Rates and Charges (Continued)

(1) The following rate elements are applicable to TLS: (Continued)

(a) UNI Port with Access Line Connection (Continued)

iv. EMS – Real Time (EMS-RT) Access Line

A monthly rate applies on a per-line basis, based on the speed of the access connection (i.e., 100 MBPS, 1000 MBPS or 10 Gbps). This enhanced service class configures a fixed portion of the UNI to be configured for Real Time Traffic, where each 100 MBPS UNI has CIR = 5 MBPS with EIR = 0 with each 1000 MBPS UNI has CIR = 10 MBPS with EIR = 0, and with each 10 Gbps UNI has CIR = 50Mbps with EIR = 0. The remainder of the UNI can be used for CIR = 0 and EIR = 0 traffic. The EMS-RT Access Line is offered on a Month-to-Month basis or as a 3 or 5 Year Term Commitment Plan. A nonrecurring charge applies to the installation of the EMS-RT Access Line provided on a Month-to-Month basis. A customer cannot mix an EMS-RT Access Line with the ERS Service type, but may mix EMS-RT Access Line with EMS Access Lines. Besides the standard connectivity model, Premier Access Line is offered with three other type of UNI Port with Access Line Connections, where facilities exist. (10 Gbps is not available for these Protected options.)

- (1) Protected Non-Diverse
- (2) Protected Diverse
- (3) Protected Private

v. Ethernet Virtual Circuit (EVC)

For customers who order the ERS Service Type with a Standard Access Line, a monthly rate will apply on a per EVC bandwidth basis. ERS Standard is the only EVC class available with the Standard Access Line. The EVC bandwidth must be equal to the bandwidth of the lowest speed of the end points it is connecting. ERS Standard EVCs are purchased on a Month-to-Month basis. A nonrecurring setup charge will apply per ERS Standard EVC.

For customers who order the Premier Access Line, a monthly rate will apply on a service class and EVC bandwidth basis. Premier Access Line customers have the choice of combining ERS-Basic, ERS-Priority Data, and/or ERS-Real Time bandwidth or combining EVPLAN-Basic and EVPLAN Real time bandwidth on an EVC. A nonrecurring setup charge will apply per ERS EVC. EVCs are purchased on a Month-to-Month basis. A customer may have more than one service class on the EVC, but will only pay one EVC nonrecurring setup charge.

Effective: April 1, 2016

FACILITIES BASED SERVICES  
(LOCAL, INTRASTATE ACCESS AND INTRALATA TOLL)

IV. PROVISIONING (Continued)

A. Intrastate Access Services (Continued)

2. TRANSPARENT LAN SERVICE (TLS) (Continued)

d. Application of Rates and Charges (Continued)

(1) The following rate elements are applicable to TLS: (Continued)

(a) UNI Port with Access Line Connection (Continued)

v. Ethernet Virtual Circuit (EVC) (Continued)

The number of EVCs permitted on each Standard Access Line and/or Premier Access Line are limited as follows :

- 10 Mbps less than or = 5 EVCs
- 100 Mbps less than or = 16 EVCs
- 1000 Mbps less than or = 205 EVCs.
- 10 Gbps less than or = 750 EVCs

ERS –Basic, ERS-Priority Data and ERS-Real Time EVC bandwidth is limited to a maximum Mbps per Service Class per EVC, and must comply with each of the following maximum limits :

EVC Service Class	10 Mbps UNI Max/EVC	100 Mbps UNI Max/EVC	1000 Mbps UNI Max/EVC	10 Gbps UNI Max/EVC
ERS-B (or) EVPLAN-B	10 Mbps	100 Mbps	1000 Mbps	1000 Mbps
ERS-PD	10 Mbps	100 Mbps	500 Mbps	500 Mbps
ERS-RT (or) EVPLAN-RT	10 Mbps	100 Mbps	100 Mbps	100 Mbps
	10 Mbps	50 Mbps	50 Mbps	N/A

(b) Domain/LAN Extension Equipment Changes

Customer requests for changes in EMS Domain and replacement of LAN extension equipment will be charged a nonrecurring charge per location, per change.

(c) Interoffice Mileage

The Interoffice Mileage charge is based on the Per Mile charge multiplied by the distance between the Customers's serving central office and the nearest TLS equipped central office (a central office equipped with a switch, node or other Company equipment capable of delivering service, via a shared fiber path or network infra-structure). This interoffice distance is measured in airline miles, based upon latitude and longitude of each central office. The mileage measurement is calculated as specified by NECA Tariff FCC No. 4.

Effective: April 1, 2016

---

FACILITIES BASED SERVICES  
(LOCAL, INTRASTATE ACCESS AND INTRALATA TOLL)

IV. PROVISIONING (Continued)

A. Intrastate Access Services (Continued)

2. TRANSPARENT LAN SERVICE (TLS) (Continued)

d. Application of Rates and Charges (Continued)

(1) The following rate elements are applicable to TLS: (Continued)

(c) Interoffice Mileage (Continued)

The mileage rate applies on a per mile basis. This charge applies in addition to the applicable rates and charges for the TLS Access Line. Optical protected mileage interoffice transport is available for the 1000M UNI speed. The protected transport option for 10/100Mbps, Protected Non-Diverse and Protected Diverse, UNI speeds includes optical protected interoffice transport when needed.

(d) Optional Features

Customer Service Management (CSM) <sup>1</sup>

Customer Service Management (CSM) is an optional feature that provides customers with web-based reports. These reports give customers the ability to extract read-only network traffic information regarding their networks, thereby allowing customers to monitor and manage their network performance. CSM reports are provided per customer Domain/VLAN.

The Utility reserves the right to temporarily interrupt CSM for maintenance, software upgrades, and in emergency situations.

A monthly rate and a nonrecurring charge apply for each CSM arrangement. The customer will be charged on a per Domain/VLAN basis. The nonrecurring charge applies to the initial installation in addition to all other applicable service charges.

(2) Minimum Period

The minimum subscription period for TLS under the Month-to-Month Option is nine months. Terms and conditions applicable to TLS provided under a Term Commitment Plan.

(3) Term Commitment Plans

The Standard Access Line, Protected Access Line <sup>1</sup>, Premier Access Line and/or EMS Real Time Access Line are offered under a 3 or 5 Year Term Commitment Plan.

<sup>1</sup> Effective February 7, 2011 is grandfathered and no longer available to new Customers. Moves, additions or changes to subscribers' existing service will not be permitted.

Effective: April 1, 2016

---

FACILITIES BASED SERVICES  
(LOCAL, INTRASTATE ACCESS AND INTRALATA TOLL)

IV. PROVISIONING (Continued)

A. Intrastate Access Services (Continued)

2. TRANSPARENT LAN SERVICE (TLS) (Continued)

d. Application of Rates and Charges (Continued)

(4) Moves and Changes

When the customer requests a move or relocation of a Standard Access Line, Protected Access Line, or EMS Real Time Access Line to a different address and/or different building, the move or relocation will be treated as a termination of the existing service and the establishment of a new service with the application of all charges.

When the Customer requests an upgrade in service speed, or change in service type, at an existing address, the upgrade in service speed/change in service type will be treated as a termination of the existing service and the establishment of a new service for the application of all charges.

Customer requests for changes in Domains and replacement of LAN extension equipment will be charged a nonrecurring charge per location per change.

(5) Termination Liability

In the event TLS is terminated by the customer prior to completion of the Term Commitment Plan, termination liability charges, as set forth in Section 2.B.15 of this Product Guide, will apply.

A change in TLS service type will be considered a change to another service for purposes of determining Termination Liability charges.

(6) Service Level Agreements (SLAs)

Service Level Agreements (SLAs) provide TLS customers with Service Response Credits (SRCs) applied to their Frontier bill if the Company fails to meet certain operational and network thresholds. SLAs are available at no additional charge or fee to the customer.

A customer is eligible for the SLA SRC given the customer adheres to the conditions stated within this section. The SLA specifies performance criteria against which actual performance for TLS will be compared on a monthly basis.

<sup>1</sup> Effective November 19, 2010, this service will no longer be available to new customers.

Effective: April 1, 2016

---

FACILITIES BASED SERVICES  
(LOCAL, INTRASTATE ACCESS AND INTRALATA TOLL)

IV. PROVISIONING (Continued)

A. Intrastate Access Services (Continued)

2. TRANSPARENT LAN SERVICE (TLS) (Continued)

d. Application of Rates and Charges (Continued)

(6) Service Level Agreements (SLAs) (Continued)

The TLS SLA includes the following measurements:

- Operational SLAs
- Mean Time to Repair (MTTR)
- Network Availability
- Network Performance SLAs
- Ethernet Virtual Circuit (EVC) Class of Service (CoS) Performance
- Data Delivery Ratio (DDR)
- Round Trip Delay (RTD)
- Jitter

The SLA SRC will apply to the following TLS elements:

- UNI Port with Access Line Connection
- Ethernet Virtual Circuit (EVC) Bandwidth, excluding EVPLAN EVCs

To receive SRCs on eligible rate elements, the customer must have the eligible rate elements listed in the initial subscription based on the established customer of record, or have ordered the eligible rate elements subsequent to the initial subscription. The Company reserves the right to change, alter or discontinue the optional SRC plan at its discretion.

All service performance and provisioning measurements are conducted using the Company monitoring systems and procedures. The Company may change these systems and procedures at its sole discretion. In performing measurements of overall Mean Time To Repair (MTTR) and Network Availability, the Company shall include data measured throughout the territories covered by this Product Guide.

To receive credit, the Company must receive from the customer a written request for credit within thirty (30) calendar days of the end of the monitoring period that the SRC is referencing. The customer's request for credit must be submitted to the appropriate Company entity (office or interface) in a manner prescribed by Company. The request must include a list of all impacted circuit/connection identification numbers and the type of SRC requested for each circuit/connection. The SRC monitoring period is based on a calendar month.

Effective: April 1, 2016

---

FACILITIES BASED SERVICES  
(LOCAL, INTRASTATE ACCESS AND INTRALATA TOLL)

IV. PROVISIONING (Continued)

A. Intrastate Access Services (Continued)

2. TRANSPARENT LAN SERVICE (TLS) (Continued)

d. Application of Rates and Charges (Continued)

(6) Service Level Agreements (SLAs) (Continued)

a. Operational Service Level Agreements (SLAs) (Continued)

- (1) Mean Time to Repair (MTTR) - MTTR is the average mean time for the Company to repair customer reported interruptions for service that is within the Company's network. A TLS service is interrupted when it becomes unusable to the customer because of a failure of a facility component within the Company's network that is used to furnish service under this Product Guide.

MTTR Measurement - Under the MTTR SLA, the Company will measure the average Time to Repair (TTR) for customer-reported interruptions in the services with respect to TLS Access Lines. To be measured under this SLA, the customer must report any interruption to a Company-designated entity for the opening of a trouble ticket. The TTR is measured from the date and time a trouble ticket is opened by the Company and the date and time when such ticket is closed by the Company. In measuring the TTR, any stop clock time or adjusted duration time associated with the trouble shall be subtracted from such measurement.

For purposes of this measurement, stop clock time refers to

- (a) periods when the customer testing is occurring;
- (b) periods when the Company is awaiting the customer's authorization to commence work on a TLS Access Line;
- (c) periods when the Company is denied access to the customer's premises or facilities as necessary to diagnose, repair or test;
- (d) periods following a repair of a TLS Access line when the ticket is held open by the customer to ensure the trouble is resolved; and,
- (e) any time period during which any of the listed occurrences existed, as set forth in d. SLA Exclusions following.

The SLA shall not apply to cases of trouble where no trouble was found or repeated cases of trouble for the same interruption. The MTTR SLA shall be measured on a calendar month basis and shall be calculated by adding the TTR for all interruptions and dividing that sum by the total number of trouble tickets opened for interruptions for the customer during that month.

MTTR SRCs - If the MTTR is greater than four (4) hours over the calendar month, then 50% of the one month TLS Access Line monthly charge shall be given as a MTTR SRC for those Access Lines which have been out of service for longer than four (4) hours and have been reported by the customer via a trouble ticket to the Company. The MTTR SRC credit excludes and is not applicable to scheduled maintenance, scheduled downtimes or delays resulting from an event of force majeure.

Effective: April 1, 2016

---

FACILITIES BASED SERVICES  
(LOCAL, INTRASTATE ACCESS AND INTRALATA TOLL)

IV. PROVISIONING (Continued)

A. Intrastate Access Services (Continued)

2. TRANSPARENT LAN SERVICE (TLS) (Continued)

d. Application of Rates and Charges (Continued)

(6) Service Level Agreements (SLAs) (Continued)

a. Operational Service Level Agreements (SLAs) (Continued)

(2) Network Availability

Network Availability refers to the percentage of time during a calendar month that the TLS is available for use by the customer.

Network Availability Measurement

The Company threshold for Network Availability is 99.90%. Network Availability is calculated on a per TLS Port Connection basis as follows:

$$\frac{(24 \times \text{Number of Days in Month} \times \text{Number of TLS Port Connections}) - (\text{Number of Hours Out of Service during Month})}{24 \times \text{Number of Days in Month} \times \text{Number of TLS Port Connections}}$$

The Company will not round up the calculation to reach the 99.90% threshold. This SLA is only available for outages reported by the customer via a trouble ticket to the Company.

Network Availability SRCs

If the overall Network Availability measurement is less than the threshold of 99.90% for a calendar month, the Company will provide a credit equal to ten percent (10%) of the associated monthly charge for any individual TLS port connection that did not meet such threshold during such calendar month.

b. Network Performance SLA

Network Performance SLA applies to all customers subscribing to an EVC Class of Service (CoS) within a local network consisting of the following types:

- Real Time EVC bandwidth CoS, and
- Priority Data EVC bandwidth CoS.
- All other EVCs do not qualify for Network Performance SLA, including EVPLAN EVCs

The performance SLA is hierarchical in nature and statistically-based. Conformance is determined on a Met or Missed basis, first on a per-hour basis and then on a per-month conformance basis.



Effective: April 1, 2016

---

FACILITIES BASED SERVICES  
(LOCAL, INTRASTATE ACCESS AND INTRALATA TOLL)

IV. PROVISIONING (Continued)

A. Intrastate Access Services (Continued)

2. TRANSPARENT LAN SERVICE (TLS) (Continued)

d. Application of Rates and Charges (Continued)

(6) Service Level Agreements (SLAs) (Continued)

b. Network Performance SLA (Continued)

**Per-Hour Conformance** - For each hour in the month, a determination is made as to whether the performance objectives are 'Met' for the CoS attributes related to the CoS instance on a given EVC. For a given Hour (e.g., H1), the overall performance objective is 'Met' if the performance objectives for each of the Data Delivery Ratio (DDR), Round Trip Delay (RTD), and Jitter, attributes are 'Met'. If any of the attribute objectives are 'Missed', then the overall performance objective for Hour (H1) is determined to be 'Missed'.

**Per-Month Conformance** - For the month, a determination is made as to the percentage of hours that the overall performance objective is 'Met'. So, for a given Month (e.g., M1), the monthly performance guarantee is 'Met' if the % of hours 'Met' for the month meet or exceed the monthly objective.

EVC Class of Service Network Performance SLA shall be based on the following Ethernet frame traffic criteria:

(1) Data Delivery Ratio (DDR)

DDR is defined as the ratio of service frames successfully received from the network relative to the number of service frames offered to the network. The DDR definition is restricted to service frames that are compliant to the subscribed Committed Information Rate (CIR) profile. Interruptions caused by MTTR activity shall be excluded from the measurement of DDR.

Real Time EVC Bandwidth - Data Delivery Ratio - The Company threshold for Data Delivery Ratio is 99.5% in a calendar month.

Real Time EVC Bandwidth - Data Delivery SRCs - If the overall Data Delivery measurement does not meet the per month conformance, the Company shall provide an SRC equal to ten percent (10%) of the monthly charge for any individual EVC that did not meet such threshold during such calendar month.

Priority Data EVC Bandwidth - Data Delivery Ratio - The Company threshold for Data Delivery Ratio is 99% in a calendar month.

Priority Data EVC Bandwidth - Data Delivery SRCs - If the overall Data Delivery measurement does not meet the per month conformance, the Company shall provide an SRC equal to ten percent (10%) of the monthly charge for any individual EVC that did not meet such threshold during such calendar month.

Effective: April 1, 2016

---

FACILITIES BASED SERVICES  
(LOCAL, INTRASTATE ACCESS AND INTRALATA TOLL)

IV. PROVISIONING (Continued)

A. Intrastate Access Services (Continued)

2. TRANSPARENT LAN SERVICE (TLS) (Continued)

d. Application of Rates and Charges (Continued)

(6) Service Level Agreements (SLAs) (Continued)

b. Network Performance SLA (Continued)

(2) Round Trip Delay (RTD)

RTD is defined as the time (in milliseconds) it takes for a service frame to be sent from one UNI to another UNI and back again (includes link insertion delays, propagation delays and queuing delays in the network). The RTD calculation includes only the time the packet is in the network, i.e., the processing time spent in devices attached to the UNI are factored out of the definition. The RTD definition is restricted to service frames that are compliant to the subscribed CIR profile.

Real Time EVC Bandwidth - Delay Measurement - The Company threshold for Delay is 20 milliseconds.

Real Time EVC Bandwidth - Delay SRCs - If the overall delay measurement does not meet the per month conformance, the Company shall provide an SRC equal to ten percent (10%) of the monthly charge for any individual EVC that did not meet such threshold during such calendar month.

Priority Data EVC Bandwidth - Delay Measurement - The Company threshold for Delay is 50 milliseconds.

Priority Data EVC Bandwidth - Delay SRCs - If the overall delay measurement does not meet the per month conformance, the Company shall provide an SRC equal to ten percent (10%) of the monthly charge for any individual EVC that did not meet such threshold during such calendar month.

(3) Jitter

Jitter is defined as the variance in frame delay (in milliseconds) between two service frames as measured at the ingress and egress UNIs. The jitter definition is restricted to service frames that are compliant to the subscribed CIR profile.

Real Time EVC Bandwidth - Jitter Measurement - The Company threshold for Delay is 5 milliseconds.

Real Time EVC Bandwidth - Jitter SRC - If the overall jitter measurement does not meet the per month conformance, the Company shall provide an SRC equal to ten percent (10%) of the monthly charge for any individual EVC that did not meet such threshold during such calendar month.

---

FACILITIES BASED SERVICES  
(LOCAL, INTRASTATE ACCESS AND INTRALATA TOLL)

IV. PROVISIONING (Continued)

A. Intrastate Access Services (Continued)

2. TRANSPARENT LAN SERVICE (TLS) (Continued)

d. Application of Rates and Charges (Continued)

(6) Service Level Agreements (SLAs) (Continued)

c. Validation for Operational and Network Performance SLAs

(1) Customer Validation

Operational SLAs:

The customer must submit in writing a list of all rate elements, impacted circuit/connection identification numbers and the type of SRC requested for each circuit/connection. The written request for credit must be submitted to the appropriate Company entity in the manner prescribed by the Company.

Network Performance SLAs:

The customer must request SRCs for Network Performance SLAs and may submit in support of such request its own measurements made by industry-standard network performance measuring equipment. Such equipment shall be subject to prior approval by the Company and be capable of the following:

**For the DDR SLA**, the equipment must be capable of determining the number of actual packets sent and successfully received between two (2) customer locations.

**For the RTD SLA**, the equipment must be capable of measuring the transmission of a series of 128-byte time-stamped packets to a measurement system from one customer location to another customer location. The measurement systems must be time-synchronized by using a network based timing source that uses Greenwich Mean Time (GMT).

**For the Jitter SLA**, the equipment must be capable of measuring the transmission of a series of at least fifty (50), 128-byte time stamped packets at a fixed interval between each packet from one customer location to a measurement system at another customer location. The measurement systems must be time-synchronized by using a network based timing source that uses Greenwich Mean Time (GMT).

All equipment must be capable of measuring from edge to edge (Customer Premises Equipment (CPE) to CPE) and to make the measurement every five (5) minutes per hour for four (4) hours total per day, for a total of two-hundred and forty (240) measures per day. In order to be considered, such measurements must include at least seven consecutive days' worth of measurements for four (4) hours per day.

Effective: April 1, 2016

---

FACILITIES BASED SERVICES  
(LOCAL, INTRASTATE ACCESS AND INTRALATA TOLL)

IV. PROVISIONING (Continued)

A. Intrastate Access Services (Continued)

2. TRANSPARENT LAN SERVICE (TLS) (Continued)

d. Application of Rates and Charges (Continued)

(6) Service Level Agreements (SLAs) (Continued)

c. Validation for Operational and Network Performance SLAs (Continued)

(2) Company Validation

The Company will research and validate the customer-submitted SRC in accordance with its own procedures and systems. The Company may, at its discretion, use either the customer-provided data or its own measurement data (or above mentioned formulas) to evaluate and assess whether SRCs are warranted.

d. SLA Exclusions

SLAs do not apply to the extent that any of the following reasons prevented the Company from meeting such SLAs:

- (1) The acts of the customer or other party authorized by the customer to use the TLS circuit/connection, including but not limited to customer's negligence, customer's refusal to grant the Company reasonable access to its premises for testing/repair, customer's refusal to release the TLS circuit/connection for testing and/or repair, customer's maintenance activities or its rearrangement of the TLS circuit/connection or where the customer has exceeded the purchased EVC bandwidth;
- (2) Subsequent reports (i.e., additional customer inquiries) while the trouble is pending;
- (3) Service troubles closed due to the customer's action;
- (4) Service troubles repaired by the Company prior to its receipt of a trouble report;
- (5) Service trouble caused by the customer's CPE or facilities on its side of the demarcation point or any power, equipment, service or systems not provided by the Company;
- (6) An Interruption related to the provisioning of a new TLS Access Line or Access Lines in service for less than a month;
- (7) Scheduled maintenance and downtimes;
- (8) Unavailability of network monitoring or management equipment or reporting;
- (9) Any other reason outside the control of the Company.

Effective: April 1, 2016

---

FACILITIES BASED SERVICES  
(LOCAL, INTRASTATE ACCESS AND INTRALATA TOLL)

IV. PROVISIONING (Continued)

A. Intrastate Access Services (Continued)

2. TRANSPARENT LAN SERVICE (TLS) (Continued)

d. Application of Rates and Charges (Continued)

(6) Service Level Agreements (SLAs) (Continued)

e. Limitations on SRCs

The combined total of any SRCs applied to the customer's TLS service for a calendar month must meet the following conditions:

- (1) For any calendar year, the total SRCs shall not exceed ten percent (10%) of the total annual revenue of the prior calendar year billed to the customer for qualifying service elements, or \$200,000 per customer, whichever is less. For any calendar year in which the customer had less than twelve (12) full months of revenue for qualifying service elements in the prior calendar year, the SRCs may not exceed \$20,000 per customer for TLS Network.
- (2) To receive an SRC, the customer must request such SRC in writing within thirty (30) calendar days of the end of the monitoring period of the referenced SRC. The request must include a list of all impacted EVC identification numbers and the type of SRC requested for each EVC.

Effective: April 1, 2016

FACILITIES BASED SERVICES  
(LOCAL, INTRASTATE ACCESS AND INTRALATA TOLL)

V. RATES AND CHARGES

A. Local Services

1. Basic Exchange Access Line Services

a. Business Service

	<u>Monthly Rate</u>
Measured-Rate Service, Each individual line or trunk line	\$19.22

b. PBX Trunk Service

Each individual trunk	24.05
-----------------------	-------

c. Direct Inward Dialing (DID) Service <sup>1, 2</sup>

(1) DID Station Numbers

	<u>Nonrecurring Charge</u>	
20 Stations	\$160.20	\$ 66.00
40 Stations	176.00	132.00
100 Stations	440.00	330.00

(2) Each Additional Block of DID Station Numbers

20 Stations	160.20	66.00
40 Stations	176.00	132.00
100 Stations	160.20	200.00

d. Rotary Service

(1) Each individual line or PBX trunk line, including foreign exchange service, arranged for rotary service.	--	1.50
--	----	------

(2) Each rotary number reserved	--	1.50
---------------------------------	----	------

<sup>1</sup> Equipment arrangement in the central office is necessary to provide in-dialing from the exchange and message toll network directly to dial switching equipment installed on the customer premises.

<sup>2</sup> Rates are in addition to the rates for other services and facilities including PBX rates. When this service is provided from a foreign exchange, rates for foreign exchange trunk lines and foreign exchange mileage rates are applicable.

Effective: April 1, 2016

---

FACILITIES BASED SERVICES  
(LOCAL, INTRASTATE ACCESS AND INTRALATA TOLL)

V. RATES AND CHARGES (Continued)

A. Local Services (Continued)

2. Local Usage-Business Service

	<u>First Minute Or Portion Thereof</u>	<u>Additional Minute Or Portion Thereof</u>
a. Measured Rate Service		
(1) Monday Through Friday		
8:00 A.M. to 5:00 P.M. <sup>1</sup>	\$.040	\$.010
5:00 P.M. to 11:00 P.M. <sup>1</sup>	.028	.007
11:00 P.M. to 8:00 A.M. <sup>1</sup>	.016	.004
(2) Saturday, Sunday, Holiday		
All Hours	.016	.004
b. Zone Usage Measurement Service (ZUM)		

**Rates** - See Section 5 of this Product Guide, Rates C.2.b, for rates applicable to calls terminating in Zone 3. No additional charges apply for calls terminating in Zone 1 and Zone 2, as these charges are included in the local calling area charges.

**Exchanges** - See Pacific Bell's Schedule Cal. P.U.C. No. A5 for a list of applicable exchanges and corresponding Zones.

<sup>1</sup> To, but not including.

Effective: April 1, 2016

FACILITIES BASED SERVICES  
(LOCAL, INTRASTATE ACCESS AND INTRALATA TOLL)

V. RATES AND CHARGES (Continued)

A. Local Services (Continued)

3. Integrated Services Digital Network (ISDN)

a. ISDN - Basic Rate Interface Services (BRI) <sup>1</sup>

	<u>Nonrecurring Charges</u>	<u>Monthly Rates</u>
(1) Basic Rate Interface Line	2	3
(2) ISDN Access - Single User	--	ICB
(3) ISDN Multipoint Access - Multiple User	--	ICB
(4) Central Office Services, per channel		
B Voice	--	ICB
B Circuit Switched Data (CSD) <sup>4</sup>	--	ICB
B Voice/CSD <sup>4</sup>	--	ICB
B Packet, per packet <sup>5</sup>	--	ICB
D Packet, per packet <sup>5</sup>	--	ICB
(5) Additional Telephone Numbers, each number	2	ICB
(6) Package Services		
Centrex Feature Packages		
Centrex 1000, 2000, 3000	--	6
ISDN Basic Station Service	ICB	ICB
ISDN Deluxe Station Service	ICB	ICB
CO Attendant Service	ICB	ICB
Data 1000, 2000 <sup>3</sup>	ICB	ICB
X.25 Basic, per channel <sup>5</sup>	--	--
X.25 Deluxe, per channel <sup>5</sup>	ICB	ICB

<sup>1</sup> Service is limited to business customers only with eight lines or more.

<sup>2</sup> Service ordering charges are applicable.

<sup>3</sup> See Section V.A.1 for rates applicable to Basic Exchange Access Line Services, and Section V.A.2 for Local Usage.

<sup>4</sup> All data calls are measured and usage charges are applicable except data calls within the same customer group.

<sup>5</sup> X.25, B Packet and D Packet services are grandfathered and limited to existing customers as of XXX XX, 2003, and subsequently, will no longer be provided after December 31, 2006. However, Frontier will continue to provide support for these services up until December 31, 2006.

<sup>6</sup> See monthly Rates and Charges in IV.D.1.



Effective: April 1, 2016

---

FACILITIES BASED SERVICES  
(LOCAL, INTRASTATE ACCESS AND INTRALATA TOLL)

V. RATES AND CHARGES (Continued)

A. Local Services (Continued)

3. Integrated Services Digital Network (ISDN) (Continued)

a. ISDN - Basic Rate Interface Services (BRI) <sup>1</sup> (Continued)

	<u>Nonrecurring Charges</u>	<u>Monthly Rates</u>
(7) Individual Services, per channel		
Data Direct Connect	--	ICB
Data Closed User Group	--	ICB
6-Way Conference	--	ICB
(8) Data Base Change, Per hour or portion thereof	ICB	--
(9) Individual Line Loop Extension <sup>2</sup>		
Basic Rate Interface <sup>3</sup>	ICB	ICB
Single Line <sup>4</sup>	ICB	ICB
(10) Exception Provisioning <sup>2</sup>		
Provisioning <sup>5</sup>	--	ICB
Special Transport Mileage, per airline mile <sup>6</sup>	--	ICB

<sup>1</sup> Service is limited to business customers only with eight lines or more.

<sup>2</sup> These rates apply in addition to the rates for Basic Rate Interface.

<sup>3</sup> Applies to BRI Single User and Multiple User.

<sup>4</sup> Applies to ISDN Business and Residence Single Line.

<sup>5</sup> There is no additional charge for Special Transport Termination.

<sup>6</sup> This rate applies on a per-line basis.

Effective: April 1, 2016

FACILITIES BASED SERVICES  
(LOCAL, INTRASTATE ACCESS AND INTRALATA TOLL)

V. RATES AND CHARGES (Continued)

A. Local Services (Continued)

3. Integrated Services Digital Network (ISDN) (Continued)

b. ISDN-Primary Rate Interface Service (PRI)

ISDN-PRI Service is available on a month-to-month basis. The minimum subscription period for this service is one month. ISDN-PRI Service can be provided from a customer's serving central office or from an alternative central office. If service is provided from an alternative central office, additional Switched Facility charges as specified in V.A.3. will apply.

	<u>Nonrecurring Charge</u>	<u>Monthly Rate</u>
(1) <u>Month-to-Month Option</u>		
(a) PRI Access Interface, per Central Office Termination	1	\$500.00 <sup>2</sup>
(b) Switched Facility (Customer's Premises to Local Central Office)		
1) Option 1		
High Capacity Digital Facility	3	3
Special Transport, per air line mile	--	3
2) Option 2		
Alternate High Capacity Digital Facilities	4	4
(c) B Channel Configurations		
1) Circuit Switched Data	1	6.00 <sup>5</sup>
2) DID/DOD Service		
First telephone number for each channel activated	1	4.00
Additional telephone numbers	1	0.40
3) Intermediary Customer Services, each	1	30.00 <sup>6</sup>
4) 800 Service	1	8.00 <sup>7</sup>
5) OutWATS Service	1	8.00 <sup>7</sup>
6) Call-by-Call Trunk	1	5.00 <sup>7, 8</sup>

<sup>1</sup> See Database Configuration, V.A.3.

<sup>2</sup> The FCC End User Common Line monthly rate and FCC ISDN Line Port monthly rates are applicable as specified in Frontier Operating Companies Tariff FCC No. 14 and Frontier Operating Companies Tariff FCC No. 13.

<sup>3</sup> See Section V.A.12 for Local High Capacity Digital Facilities rates.

<sup>4</sup> DS1, DS3 or any other compatible High Capacity Digital Facility that meets specifications determined by the Company and offered on a month-to-month basis may be utilized in lieu of the Switched Facility specified in Option 1. See appropriate Company tariff or Product Guide for applicable rates and terms.

<sup>5</sup> This rate is in addition to Local Usage charges as specified in V.A.2 for all originating data calls.

<sup>6</sup> This rate applies only to ISDN-PRI facilities that extend from the ISDN-PRI serving central office to the Intermediary Customer. In order to send calls to the Intermediary Customer, local loop access from the customer's premises to the customer's ISDN-PRI service central office is also needed (e.g., Centrex, DID/DOD trunk, or Call-by-Call trunk).

<sup>7</sup> This rate is addition to the applicable rates for 800 Service/OutWATS Service as specified in Section 26 of this Product Guide. Charges assessed by Intermediary Customer Services providers will also apply.

<sup>8</sup> Call-by-Call Trunk supports Circuit Switched Data and DID/DOD Service.

Effective: April 1, 2016

FACILITIES BASED SERVICES  
(LOCAL, INTRASTATE ACCESS AND INTRALATA TOLL)

V. RATES AND CHARGES (Continued)

A. Local Services (Continued)

3. Integrated Services Digital Network (ISDN) (Continued)

b. ISDN-Primary Rate Interface Service (PRI)

	<u>Nonrecurring Charge</u>	<u>Monthly Rate</u>
(1) <u>Month-to-Month Option</u> (Continued)		
(d) Database Configuration		
1) Initial and Subsequent Service Order,		
a) PRI Access Interface, each	\$200.00	--
b) B Channel, per type	200.00	--

(e) Foreign Exchange (Alternative Central Office)

If ISDN-PRI Service is provided from an alternative central office, the following additional charges are applicable:

1) Switched Facility (Local Central Office to ISDN-PRI Capable Central Office)

a) Option 1		
1. High Capacity Digital Facility	1	1
2. Special Transport, per airline mile	--	1
- or -		
Metro Ethernet Special Transport	--	1
b) Option 2		
1. Alternate High Capacity Digital Facilities	2	2

4. Digital Channel Service

a. Nonrecurring Charges

(1) Service Establishment Charge	
Initial	ICB
Subsequent	ICB
(2) Service Change Charge	
Per Digital Channel Capacity, Per 24 channel increment	ICB
(3) Configuration Charge, Per Occurrence	ICB
(4) Premises Visit Charge, Per Visit	ICB

<sup>1</sup> See Section V.A.12 for Local High Capacity Digital Facilities rates. In Metro Ethernet designated serving areas, the Metro Ethernet Special Transport rate specified in Section V.A.12.c may be used in lieu of the rate for Special Transport.

<sup>2</sup> DS1, DS3 or any other compatible High Capacity Digital Facility that meets specifications determined by the Company and offered on a month-to-month basis may be utilized in lieu of the Switched Facility specified in Option 1. See appropriate Company tariff or Product Guide for applicable rates and terms.

Effective: April 1, 2016

FACILITIES BASED SERVICES  
(LOCAL, INTRASTATE ACCESS AND INTRALATA TOLL)

V. RATES AND CHARGES (Continued)

A. Local Services (Continued)

4. Digital Channel Service (Continued)

b. Digital Channel Capacity

	<u>Nonrecurring Charge</u>	<u>Monthly Rate</u>
(1) Per System		
24 Digital Channels	ICB	ICB
48 Digital Channels	ICB	ICB
72 Digital Channels	ICB	ICB
96 Digital Channels	ICB	ICB
120 Digital Channels	ICB	ICB
144 Digital Channels	ICB	ICB
192 Digital Channels	ICB	ICB
240 Digital Channels	ICB	ICB
288 Digital Channels	ICB	ICB
384 Digital Channels	ICB	ICB
480 Digital Channels	ICB	ICB
576 Digital Channels	ICB	ICB
672 Digital Channels	ICB	ICB
1344 Digital Channels	ICB	ICB
2016 Digital Channels	ICB	ICB
(2) Digital Interoffice Transport	ICB	ICB
c. Digital Channel Activation, Per Digital Channel Activated <sup>1</sup>	ICB	ICB
d. Service Activations, Per Network Service		
(1) Analog Service		
Exchange Line / Trunk	ICB	ICB
Centrex Station Line	ICB	ICB
(2) Foreign Exchange, Off Premises Extension, Private Line, Tie Line, Intrastate Wats <sup>2</sup> /800	ICB	ICB

<sup>1</sup> Does not apply to DS1 Service.

<sup>2</sup> Wide Area Telecommunications Service (WATS) is grandfathered and limited to existing customers at existing locations as of January 13, 2005.

Effective: April 1, 2016

FACILITIES BASED SERVICES  
(LOCAL, INTRASTATE ACCESS AND INTRALATA TOLL)

V. RATES AND CHARGES (Continued)

A. Local Services (Continued)

4. Digital Channel Service (Continued)

d. Service Activations, Per Network Service (Continued)

	<u>Nonrecurring Charge</u>	<u>Monthly Rate</u>
(3) Digital Data Service 2.4 Kbps, 4.8 Kbps, 9.6 Kbps, 19.2 Kbps	ICB	ICB
(4) Digital Data Service 56 Kbps	ICB	ICB
(5) DS1 Service 1.544 Mbps	ICB	ICB
(6) Switched Data Service <sup>1</sup>	ICB	ICB

e. Measured Rate Service - Local Usage

Applies to Service Activations - Analog Service. Refer to V.A.2 for usage rates.

f. Customer Premises Channelization - Company Provided on Customer Premises

(1) Digital Channel Capacity	<u>Nonrecurring Charge</u>	<u>Monthly Rate</u>
24 Digital Channels	--	ICB
48 Digital Channels	--	ICB
72 Digital Channels	--	ICB
96 Digital Channels	--	ICB
120 Digital Channels	--	ICB
144 Digital Channels	--	ICB
192 Digital Channels	--	ICB
240 Digital Channels	--	ICB
288 Digital Channels	--	ICB
384 Digital Channels	--	ICB
480 Digital Channels	--	ICB
576 Digital Channels	--	ICB
672 Digital Channels	--	ICB
1344 Digital Channels	--	ICB
2016 Digital Channels	--	ICB

<sup>1</sup> Network Usage rates will be billed in accordance with rates and conditions for Local and ZUM calls as specified in Section V.A.2, and for IntraLATA Toll calls as set forth in Section IV.C.

Effective: April 1, 2016

FACILITIES BASED SERVICES  
(LOCAL, INTRASTATE ACCESS AND INTRALATA TOLL)

V. RATES AND CHARGES (Continued)

A. Local Services (Continued)

4. Digital Channel Service (Continued)

f. Customer Premises Channelization - Company Provided on Customer Premises (Continued)

(2) Service Activation, Per Channel

	<u>Nonrecurring Charge</u>	<u>Monthly Rate</u>
(a) Analog Service Exchange Line / Trunk	ICB	ICB
Centrex Station Line	ICB	ICB
(b) Foreign Exchange, Off Premises Extension, Private Line, Tie Line, Intrastate Wats 1/800	ICB	ICB
(c) Digital Data Service 2.4 Kbps, 4.8 Kbps, 9.6 Kbps	ICB	ICB
(d) Digital Data Service 56 Kbps	ICB	ICB
(e) Switched Data Service	ICB	ICB

5. Centrex Service - Newport Beach Exchange Only

The rates, terms and conditions set forth in Section 8 of this Product Guide shall apply to Centrex Service provided in the Newport Beach exchange.

6. Custom Calling Service - Newport Beach Exchange Only

The rates, terms and conditions set forth in Section 6 of this Product Guide shall apply to Custom Calling Service provided in the Newport Beach exchange.

7. Discount Calling Plans - Newport Beach Exchange Only

Residential Value Cents

Per line	See Section 19 of this Product Guide for rates
Per minute	See Section 19 of this Product Guide for rates

<sup>1</sup> Wide Area Telecommunications Service (WATS) is grandfathered and limited to existing customers at existing locations as of January 13, 2005.

FACILITIES BASED SERVICES  
(LOCAL, INTRASTATE ACCESS AND INTRALATA TOLL)

V. RATES AND CHARGES (Continued)

A. Local Services (Continued)

8. Service Provider Number Portability (SPNP) Service

The rates, terms and conditions set forth in the General Exchange Tariff, Schedule No. K-3 shall apply to Service Provider Number Portability.

9. Local Network Interconnection

Interconnection to Frontier's Local Network will be provided via negotiated agreement on a case by case basis.

10. Telephone Directory Service - Newport Beach Exchange Only

- a. Additional Listings - Residence See Section 21 of this Product Guide for rates
- b. Nonpublished Listing Services See Section 21 of this Product Guide for rates

11. Inside Wire Maintenance

a. Intrabuilding Network Cable (INC)

(1) Consultation and Design For New Installation and Rearrangements

	<u>Rate</u>	
	<u>Technician</u>	<u>Professional Engineer</u>
(a) Each hour or fraction thereof		
Weekdays (Weekdays, except holidays 8:00 a.m. to 5:00 p.m.)	\$60.00	\$120.00
After Hours (Weekdays 5:00 p.m. to 8:00 a.m. and Saturdays, except holidays)	90.00	180.00
Sundays and Holidays	120.00	240.00
(b) Charges for Design Materials / Drawings		
Company provided material price <sup>1</sup>		<u>Rate</u> ICB

<sup>1</sup> Includes two copies of design. Minimum charge is \$50.00.

Effective: April 1, 2016

---

FACILITIES BASED SERVICES  
(LOCAL, INTRASTATE ACCESS AND INTRALATA TOLL)

V. RATES AND CHARGES (Continued)

A. Local Services (Continued)

11. Inside Wire Maintenance (Continued)

a. Intrabuilding Network Cable (INC) (Continued)

Rate

(2) Installation and Rearrangements of INC

(a) Each hour or fraction thereof

Weekdays

(Weekdays, except holidays 8:00 a.m. to 5:00 p.m.)

\$75.00

After Hours

(Weekdays 5:00 p.m. to 8:00 a.m. and Saturdays, except holidays)

112.00

Sundays and Holidays

150.00

(b) Company Provided Material Prices

ICB

(3) Repair and Maintenance of INC

(a) Each hour or fraction thereof

Weekdays

(Weekdays, except holidays 8:00 a.m. to 5:00 p.m.)

75.00

After Hours

(Weekdays 5:00 p.m. to 8:00 a.m. and Saturdays, except holidays)

112.00

Sundays and Holidays

150.00

(b) Company Provided Material Prices

ICB



Effective: April 1, 2016

FACILITIES BASED SERVICES  
(LOCAL, INTRASTATE ACCESS AND INTRALATA TOLL)

V. RATES AND CHARGES (Continued)

A. Local Services (Continued)

11. Inside Wire Maintenance (Continued)

a. Intra-building Network Cable (INC) (Continued)

(3) Repair and Maintenance of INC (Continued)

(c) Service Agreement Plan <sup>1</sup>

1) Basic Repair Service

Basic Repair During Office Hours - An annual rate of 1.5 percent of the capital value of the Intra-building Network Cable (INC) infrastructure or a minimum of \$80.00 per year.

2) Intra-building Cable - Capital Value Prices <sup>2</sup>

Cable Length (ft.)	Up to 50 <u>Pair</u>	100 <u>Pair</u>	200 <u>Pair</u>	300 <u>Pair</u>	400 <u>Pair</u>	600 <u>Pair</u>	900 <u>Pair</u>
Up to 100	\$ 1,349	\$ 1,468	\$ 1,659	\$ 2,666	\$ 2,896	\$ 3,287	\$ 4,178
101 - 300	2,867	3,067	3,465	5,470	5,904	6,625	8,379
301 - 500	4,354	4,656	5,261	8,264	8,902	9,951	12,626
501 - 1000	8,457	8,941	10,061	15,890	17,038	18,964	24,046
1001 - 1500	12,495	13,179	14,818	23,514	25,172	27,972	35,464
1501 & longer	16,532	17,418	19,574	31,139	33,307	36,982	46,883

Rate

(4) Additional Local Loop Demarcation Point (LLDP) Charge

3

(5) Charge for Copies of INC Charts and Diagrams

Company Provided Material Prices

ICB

<sup>1</sup> ICB rates are applicable for customers with greater than 900 pairs or for customers who require fixed term contracts for greater than one year.

<sup>2</sup> Prices listed reflect standard installation procedures and conditions for 24 gauge INC cable and apparatus only. Special applications, including but not limited to armored cable, poles, coax, Company-owned duct structure, etc., will be provided and priced on an Individual Case Basis (ICB).

<sup>3</sup> See the General Exchange Tariff, Schedule D&R No. 27, Aerial Service Connection Facilities, or Underground Service Connections.

Effective: April 1, 2016

FACILITIES BASED SERVICES  
(LOCAL, INTRASTATE ACCESS AND INTRALATA TOLL)

V. RATES AND CHARGES (Continued)

A. Local Services (Continued)

11. Inside Wire Maintenance (Continued)

a. Intrabuilding Network Cable (INC) (Continued)

(6) Flexible Rates

This section contains flexible rates for services listed below.

The rates set forth in V.A.11.a.(1), (2) and (3) may be raised (not to exceed the maximum) or lowered by the Company with at least 30 days prior notice to the C.P.U.C. before the effective date. The current rates will be set forth on the following basis.

	<u>Maximum</u>		<u>Rate</u>	<u>Minimum</u>
(a) Installation, Rearrangement and Repair of INC				
1) Each hour or fraction thereof				
Weekdays	\$ 75.00			\$ 70.00
After hours	112.00			105.00
Sundays & Holidays	150.00			140.00
			<u>Rate</u>	
(b) Service Agreement Plan			1	
	<u>Professional Technician</u>		<u>Engineer</u>	
	<u>Max</u>	<u>Min</u>	<u>Max</u>	<u>Min</u>
(c) Consultation and Design				
Each hour or fraction thereof				
Weekdays	\$60.00	\$55.00	\$120.00	\$110.00
After hours	90.00	83.00	180.00	165.00
Sundays & Holidays	120.00	110.00	240.00	220.00

b. Complex Inside Wire

Complex Inside Wire is deregulated and is not subject to the provisions of this Product Guide.

<sup>1</sup> Refer to V.A.11.a.(3).(c) for Rates and Charges.

Effective: April 1, 2016

FACILITIES BASED SERVICES  
(LOCAL, INTRASTATE ACCESS AND INTRALATA TOLL)

V. RATES AND CHARGES (Continued)

A. Local Services (Continued)

11. Inside Wire Maintenance (Continued)

c. Inside Wire Maintenance (IWM) - Newport Beach Exchange Only

	<u>Rate</u>
(1) Simple Inside Wire Maintenance	
(a) Residential Service, each line	1
(b) Business Service, each line	1
(c) Centrex Service, each line	1

12. High Capacity Facilities

	<u>Nonrecurring Charge</u>	<u>Monthly Rate</u>
a. DS1 Service		
(1) Special Transport Termination		
High Capacity Digital DS1 (1.544 Mbps), Per Termination		ICB
(2) Special Transport Facility		
High Capacity Digital DS1 (1.544 Mbps), Per Airline Mile		ICB
(3) Special Access Line (SAL)		
(a) First System		
End User Location	ICB	ICB
IC POP Location	ICB	
Each .15 facility mile or fraction thereof, up to and including .675 facility mile		ICB
Over .675 facility mile		ICB
(b) Each Additional System		
End User Location	ICB	ICB
IC POP Location	ICB	
Each .15 facility mile or fraction thereof, up to and including .675 facility mile		ICB
Over .675 facility mile		ICB

<sup>1</sup> See Section 6 of the Product Guide for rates.

Effective: April 1, 2016

FACILITIES BASED SERVICES  
(LOCAL, INTRASTATE ACCESS AND INTRALATA TOLL)

V. RATES AND CHARGES (Continued)

A. Local Services (Continued)

12. High Capacity Facilities (Continued)

	Nonrecurring <u>Charge</u>	Monthly <u>Rate</u>
a. DS1 Service (Continued)		
(4) Special Access Line (SAL), Optional Payment Plan		
(a) First System SAL		
Month to Month	--	ICB
One Year Term	--	ICB
Three Year Term	--	ICB
Five Year Term	--	ICB
b. DS3 Service		
All arrangements	ICB	ICB
c. Metro Ethernet Service		
Special Transport, per DS1 or DS3	--	ICB

Effective: April 1, 2016

FACILITIES BASED SERVICES  
(LOCAL, INTRASTATE ACCESS AND INTRALATA TOLL)

V. RATES AND CHARGES (Continued)

A. Local Services (Continued)

13. Advanced Data Services

a. Frame Relay Service <sup>1</sup>

	<u>Nonrecurring Charge</u>	<u>Monthly Rate</u>
(1) Frame Relay Port, each <sup>2</sup>		
56 Kbps		
Month-to-Month	\$250.00	\$70.00
One Year Term	250.00	65.00
Three Year Term	250.00	60.00
Five Year Term	250.00	55.00
128 (2 x 64) Kbps		
Month-to-Month	350.00	80.00
One Year Term	350.00	75.00
Three Year Term	350.00	70.00
Five Year Term	350.00	68.00
256 (4 x 64) Kbps		
Month-to-Month	350.00	115.00
One Year Term	350.00	110.00
Three Year Term	350.00	105.00
Five Year Term	350.00	100.00
384 (6 x 64) Kbps		
Month-to-Month	350.00	145.00
One Year Term	350.00	140.00
Three Year Term	350.00	135.00
Five Year Term	350.00	130.00
1.544 Mbps		
Month-to-Month	450.00	240.00
One Year Term	450.00	235.00
Three Year Term	450.00	230.00
Five Year Term	450.00	225.00

<sup>1</sup> This service is withdrawn effective February 20, 2005.

<sup>2</sup> Rate includes one PVC but does not include the access line rate.

Effective: April 1, 2016

FACILITIES BASED SERVICES  
(LOCAL, INTRASTATE ACCESS AND INTRALATA TOLL)

V. RATES AND CHARGES (Continued)

A. Local Services (Continued)

13. Advanced Data Services (Continued)

a. Frame Relay Service <sup>1</sup> (Continued)

	<u>Nonrecurring Charge</u>	<u>Monthly Rate</u>
(2) Frame Relay Port and Access Line, each <sup>2</sup>		
56 Kbps		
Month-to-Month	\$850.00	\$175.00
One Year Term	850.00	170.00
Three Year Term	250.00	165.00
Five Year Term	250.00	160.00
128 (2 x 64) Kbps		
Month-to-Month	950.00	550.00
One Year Term	950.00	535.00
Three Year Term	350.00	520.00
Five Year Term	350.00	505.00
384 (6 x 64) Kbps		
Month-to-Month	950.00	550.00
One Year Term	950.00	535.00
Three Year Term	350.00	520.00
Five Year Term	350.00	505.00
1.544 Mbps		
Month-to-Month	1,050.00	900.00
One Year Term	1,050.00	870.00
Three Year Term	450.00	850.00
Five Year Term	450.00	830.00
(3) Data Link Connection Identifier (DLCI), each		
2 to 10 PVCs	10.00	8.00
11 to 20 PVCs	10.00	7.00
21 or more PVCs	10.00	6.00
(4) Customer Network Management (CNM)	60.00	10.00
(5) Subsequent Activity Charge, per port	10.00	--

<sup>1</sup> This service is withdrawn effective February 20, 2005.

<sup>2</sup> Rate includes one PVC and the access line.

Effective: April 1, 2016

FACILITIES BASED SERVICES  
(LOCAL, INTRASTATE ACCESS AND INTRALATA TOLL)

V. RATES AND CHARGES (Continued)

A. Local Services (Continued)

13. Advanced Data Services (Continued)

b. BaseT Ethernet Digital Connect Switch Service

	<u>Nonrecurring Charge</u>	<u>Monthly Rate</u>
(1) SMDS Connection, per port		
(a) 1.544 Mbps		
1) With Access Line	\$1,000.00	\$700.00
2) Without Access Line <sup>2</sup>	25.00	575.00
(b) Class 1 (4 Mbps)		
1) With Access Line	1,000.00	2,600.00
2) Without Access Line <sup>2</sup>	25.00	1,050.00
(c) Class 2 (10 Mbps)		
1) With Access Line	1,000.00	2,800.00
2) Without Access Line <sup>2</sup>	25.00	1,250.00
(2) Subsequent Activity Charge, per SNI affected	25.00	
(3) Optional Features		
(a) Group Address Creation, per list	50.00	
(b) Customer Network Management (CNM) <sup>3</sup>	40.00	19.00

<sup>1</sup> This service is grandfathered and limited to existing customers only as of March 25, 2002.

<sup>2</sup> For customers requiring a digital high capacity special access line, rates, terms and conditions for that service are applicable.

<sup>3</sup> Customer Network Management (CNM) is available only where facilities and conditions permit.

Effective: April 1, 2016

FACILITIES BASED SERVICES  
(LOCAL, INTRASTATE ACCESS AND INTRALATA TOLL)

V. RATES AND CHARGES (Continued)

B. Intrastate Access Services

1. Switched Access Services

Frontier California Inc., (Frontier) concurs in the conditions and regulations in Frontier's Facilities for Intrastate Access Tariff C-1 including amendments and successive issues of such tariff. The Company hereby makes itself a party to the provisions of such tariff or Product Guide until this authority is revoked by cancellation of this adoption notice. By making itself a party, the Company furnishes facilities for intrastate access service originating or terminating at a point of the Company.

a.	<u>Switched Access Installation and Ordering Charges</u>	<u>Nonrecurring Charge</u>
(1)	Switched Access Ordering Charge - Per ASR	\$46.00
(2)	Design Change Charge - Per ASR/Per Occurrence	21.75
b.	<u>Switched Transport</u>	
(1)	Tandem-Switched Transport - Facility Per Airline Mile	<u>Per Access Minute</u>
	Zone 1	0.00004300
	Zone 2	0.00004300
	Zone 3	0.00004300
(2)	Tandem-Switched Transport - Termination Per Termination	
	Zone 1	0.0002700
	Zone 2	0.0002700
	Zone 3	0.0002700
(3)	Tandem Switching Rate	
	Zone 1	0.0009940
	Zone 2	0.0009940
	Zone 3	0.0009940
(4)	Network Interconnection Rate	
	Zone 1	0.0044880
	Zone 2	0.0044880
	Zone 3	0.0044880



Effective: April 1, 2016

---

FACILITIES BASED SERVICES  
(LOCAL, INTRASTATE ACCESS AND INTRALATA TOLL)

V. RATES AND CHARGES (Continued)

B. Intrastate Access Services (Continued)

1. Switched Access Services (Continued)

b. Switched Transport (Continued)

(5)	Direct-Trunked Transport Facility-Voiceband Per Airline Mile	<u>Monthly Rate</u>
	Zone 1	\$3.71
	Zone 2	3.71
	Zone 3	3.71
(6)	Direct-Trunked Transport-Facility-DS1 Per Airline Mile	
	Zone 1	14.19
	Zone 2	14.42
	Zone 3	14.66
	Direct-Trunked Transport-Termination-DS1	
	Zone 1	56.19
	Zone 2	61.00
	Zone 3	66.21
(7)	Direct-Trunked Transport-Facility-DS3 Per Airline Mile	
	Zone 1	41.33
	Zone 2	41.33
	Zone 3	41.33
	Direct-Trunked Transport-Termination-DS3	
	Zone 1	472.90
	Zone 2	520.18
	Zone 3	567.47

FACILITIES BASED SERVICES  
(LOCAL, INTRASTATE ACCESS AND INTRALATA TOLL)

V. RATES AND CHARGES (Continued)

B. Intrastate Access Services (Continued)

1. Switched Access Services (Continued)

b. Switched Transport (Continued)

(8) Entrance Facility - 2-Wire & 4-Wire Voiceband	<u>Per Entrance Facility</u>
Service Installation Charge	\$0.00
Entrance Facility - 2-Wire Voiceband	<u>Monthly Rate</u>
Zone 1	\$28.37
Zone 2	28.37
Zone 3	28.37
Entrance Facility - 4-Wire Voiceband	
Zone 1	\$41.61
Zone 2	41.61
Zone 3	41.61
(9) Entrance Facility – DS1	<u>Service Installation</u>
First System	\$599.16
Each Additional System	283.74
Entrance Facility - DS1	<u>Monthly Rate</u>
First System	
Zone 1	\$117.28
Zone 2	127.68
Zone 3	137.14
Each Additional System	
Zone 1	117.28
Zone 2	127.68
Zone 3	137.14

FACILITIES BASED SERVICES  
 (LOCAL, INTRASTATE ACCESS AND INTRALATA TOLL)

V. RATES AND CHARGES (Continued)

B. Intrastate Access Services (Continued)

1. Switched Access Services (Continued)

b. Switched Transport (Continued)

(10)	Entrance Facility - DS3	<u>Service Installation</u>
	Electrical Interface	\$3073.82
	Optical Interface	2128.03
		<u>Monthly Rate</u>
	Electrical Interface	
	Zone 1	\$2364.48
	Zone 2	2364.48
	Zone 3	2364.48
	Optical Interface	
	Zone 1	1560.55
	Zone 2	1560.55
	Zone 3	1560.55
(11)	Multiplexing	<u>Service Installation</u>
	DS1 to Voice	\$0.00
	DS3 to DS1	0.00
		<u>Monthly Rate</u>
	DS1 to Voice	
	Zone 1	\$236.45
	Zone 2	260.09
	Zone 3	283.74
	DS3 to DS1	
	Zone 1	307.38
	Zone 2	331.03
	Zone 3	354.67

Effective: April 1, 2016

---

FACILITIES BASED SERVICES  
(LOCAL, INTRASTATE ACCESS AND INTRALATA TOLL)

V. RATES AND CHARGES (Continued)

B. Intrastate Access Services (Continued)

1. Switched Access Services (Continued)

c. End Office Services

(1)	End Office Switching - Bundled Per Access Minute	.0019010
(2)	Basic and Premium 800 Database Query Per Query	.004530

d. Network Blocking Charge

Applies to FGB, FGD, and SAC Access Service Per Call	\$ .03
---	--------

e. 500 NXX Translation Nonrecurring Charge

(1)	Initial NXX Per End Office	\$154.16
(2)	Subsequent NXX Per End Office (on the same ASR)	139.98

f. Carrier Identification Parameter (CIP)

Per CIC, Per End Office Direct Trunk	<u>Nonrecurring Charge</u> \$80.00
---	---------------------------------------

Per CIC, Per Access Tandem Direct Trunk	1,120.00
--	----------

	<u>Monthly Rate</u>
Per Trunk	\$0.46

FACILITIES BASED SERVICES  
(LOCAL, INTRASTATE ACCESS AND INTRALATA TOLL)

V. RATES AND CHARGES (Continued)

B. Intrastate Access Services (Continued)

2. High Capacity Facilities

	<u>Nonrecurring Charges</u>	<u>Monthly Rate</u>
a. High Capacity Digital DS1 (1.544 Mbps) Facilities <sup>1</sup>		
(1) Standard Arrangements		
(a) Special Access Line, First and Additional Systems		
One Year Term	--	\$ 210.00
Three Year Term	--	175.00
Five Year Term	--	150.00
(b) Special Transport Termination	--	25.00
(c) Special Transport, per airline mile	--	10.00
(d) Clear Channel	--	35.00
b. High Capacity Digital DS3 (44.736 Mbps) Facilities - Three System <sup>1</sup>		
(1) Protected DS3 - Electrical Interface		
(a) Special Access Line, First and Additional Systems <sup>2</sup>		
One Year Term	--	2,130.00
Three Year Term	--	1,735.00
Five Year Term	--	1,575.00
(b) Special Transport Termination	--	262.00
(c) Special Transport, per airline mile	--	28.00
(d) M1/3 Multiplexing	--	295.00

<sup>1</sup> Out of Franchise DS1 and DS3 Services are limited to Los Angeles County.

Effective: April 1, 2016

FACILITIES BASED SERVICES  
(LOCAL, INTRASTATE ACCESS AND INTRALATA TOLL)

V. RATES AND CHARGES (Continued)

B. Intrastate Access Services (Continued)

2. High Capacity Facilities (Continued)

	<u>Nonrecurring Charges</u>	<u>Monthly Rate</u>
c. Optical Networking (SONET) Facilities		
(1) Custom Connect CO Node		
(a) <u>OC3</u>		
One Year Term	\$1,500.00	\$900.00
Three Year Term	1,500.00	870.00
Five Year Term	1,500.00	825.00
Seven Year Term	1,500.00	775.00
(b) <u>OC12</u>		
One Year Term	3,000.00	2,150.00
Three Year Term	3,000.00	2,025.00
Five Year Term	3,000.00	1,975.00
Seven Year Term	3,000.00	1,925.00
(2) Custom Connect CDL Link - Single Route		
(a) Carrier Electronics		
1) <u>OC3</u>		
<u>With Carrier Electronics</u>		
One Year Term	3,000.00	950.00
Three Year Term	3,000.00	900.00
Five Year Term	3,000.00	875.00
Seven Year Term	3,000.00	825.00
<u>Without Carrier Electronics</u>		
One Year Term	1,500.00	620.00
Three Year Term	1,500.00	595.00
Five Year Term	1,500.00	570.00
Seven Year Term	1,500.00	545.00

FACILITIES BASED SERVICES  
(LOCAL, INTRASTATE ACCESS AND INTRALATA TOLL)

V. RATES AND CHARGES (Continued)

B. Intrastate Access Services (Continued)

2. High Capacity Facilities (Continued)

	<u>Nonrecurring Charges</u>	<u>Monthly Rate</u>
c. Optical Networking (SONET) Facilities (Continued)		
(2) Custom Connect CDL Link - Single Route (Continued)		
(a) Carrier Electronics (Continued)		
2) OC3c		
<u>With Carrier Electronics</u>		
One Year Term	\$6,000.00	\$3,050.00
Three Year Term	6,000.00	2,950.00
Five Year Term	6,000.00	2,800.00
Seven Year Term	6,000.00	2,750.00
3) OC12		
<u>With Carrier Electronics</u>		
One Year Term	6,000.00	2,450.00
Three Year Term	6,000.00	2,250.00
Five Year Term	6,000.00	2,050.00
Seven Year Term	6,000.00	1,900.00
<u>Without Carrier Electronics</u>		
One Year Term	1,500.00	1,100.00
Three Year Term	1,500.00	1,050.00
Five Year Term	1,500.00	1,020.00
Seven Year Term	1,500.00	995.00
4) OC12c		
<u>With Carrier Electronics</u>		
One Year Term	6,000.00	6,400.00
Three Year Term	6,000.00	6,150.00
Five Year Term	6,000.00	5,950.00
Seven Year Term	6,000.00	5,850.00

Effective: April 1, 2016

FACILITIES BASED SERVICES  
(LOCAL, INTRASTATE ACCESS AND INTRALATA TOLL)

V. RATES AND CHARGES (Continued)

B. Intrastate Access Services (Continued)

2. High Capacity Facilities (Continued)

	<u>Nonrecurring Charges</u>	<u>Monthly Rate</u>
c. Optical Networking (SONET) Facilities (Continued)		
(3) Custom Connect CDL Link - Diverse Route		
(a) Carrier Electronics		
1) OC3		
<u>With Carrier Electronics</u>		
One Year Term	\$3,000.00	\$1,675.00
Three Year Term	3,000.00	1,595.00
Five Year Term	3,000.00	1,545.00
Seven Year Term	3,000.00	1,490.00
<u>Without Carrier Electronics</u>		
One Year Term	3,000.00	1,190.00
Three Year Term	3,000.00	1,100.00
Five Year Term	3,000.00	1,055.00
Seven Year Term	3,000.00	1,020.00
2) OC3c		
<u>With Carrier Electronics</u>		
One Year Term	6,000.00	3,800.00
Three Year Term	6,000.00	3,550.00
Five Year Term	6,000.00	3,300.00
Seven Year Term	6,000.00	3,150.00
3) OC12		
<u>With Carrier Electronics</u>		
One Year Term	6,000.00	3,050.00
Three Year Term	6,000.00	2,725.00
Five Year Term	6,000.00	2,575.00
Seven Year Term	6,000.00	2,400.00
<u>Without Carrier Electronics</u>		
One Year Term	3,000.00	2,200.00
Three Year Term	3,000.00	2,100.00
Five Year Term	3,000.00	2,050.00
Seven Year Term	3,000.00	1,995.00



FACILITIES BASED SERVICES  
(LOCAL, INTRASTATE ACCESS AND INTRALATA TOLL)

V. RATES AND CHARGES (Continued)

B. Intrastate Access Services (Continued)

2. High Capacity Facilities (Continued)

	<u>Nonrecurring Charges</u>	<u>Monthly Rate</u>
c. Optical Networking (SONET) Facilities (Continued)		
(3) Custom Connect CDL Link - Diverse Route (Continued)		
(a) Carrier Electronics (Continued)		
4) OC12c		
<u>With Carrier Electronics</u>		
One Year Term	\$6,000.00	\$7,200.00
Three Year Term	6,000.00	7,000.00
Five Year Term	6,000.00	6,800.00
Seven Year Term	6,000.00	6,575.00
(4) Custom Connect CDL Link - Ring Route		
(a) Carrier Electronics		
1) OC3		
<u>With Carrier Electronics</u>		
One Year Term	3,000.00	2,590.00
Three Year Term	3,000.00	2,400.00
Five Year Term	3,000.00	2,325.00
Seven Year Term	3,000.00	2,250.00
<u>Without Carrier Electronics</u>		
One Year Term	3,000.00	2,100.00
Three Year Term	3,000.00	1,990.00
Five Year Term	3,000.00	1,875.00
Seven Year Term	3,000.00	1,775.00

Effective: April 1, 2016

FACILITIES BASED SERVICES  
(LOCAL, INTRASTATE ACCESS AND INTRALATA TOLL)

V. RATES AND CHARGES (Continued)

B. Intrastate Access Services (Continued)

2. High Capacity Facilities (Continued)

	<u>Nonrecurring Charges</u>	<u>Monthly Rate</u>
c. Optical Networking (SONET) Facilities (Continued)		
(4) Custom Connect CDL Link - Ring Route		
(a) Carrier Electronics		
2) OC12		
<u>With Carrier Electronics</u>		
One Year Term	\$6,000.00	\$4,100.00
Three Year Term	6,000.00	3,875.00
Five Year Term	6,000.00	3,675.00
Seven Year Term	6,000.00	3,500.00
<u>Without Carrier Electronics</u>		
One Year Term	3,000.00	3,300.00
Three Year Term	3,000.00	3,150.00
Five Year Term	3,000.00	3,050.00
Seven Year Term	3,000.00	2,950.00
(5) Custom Connect CDL Link - Single Route		
(a) Optical Cross Connect		
1) OC3/OC3c		
<u>With Optical Cross Connect</u>		
One Year Term	1,000.00	715.00
Three Year Term	1,000.00	690.00
Five Year Term	1,000.00	675.00
Seven Year Term	1,000.00	650.00
2) OC12/OC12c		
<u>With Optical Cross Connect</u>		
One Year Term	2,500.00	1,640.00
Three Year Term	2,500.00	1,590.00
Five Year Term	2,500.00	1,550.00
Seven Year Term	2,500.00	1,500.00

Effective: April 1, 2016

FACILITIES BASED SERVICES  
(LOCAL, INTRASTATE ACCESS AND INTRALATA TOLL)

V. RATES AND CHARGES (Continued)

B. Intrastate Access Services (Continued)

2. High Capacity Facilities (Continued)

	<u>Nonrecurring Charges</u>	<u>Monthly Rate</u>
c. Optical Networking (SONET) Facilities (Continued)		
(6) Custom Connect - Rider		
DS1	--	\$75.00
DS3	--	250.00
STS1	--	240.00
OC3c	--	750.00
OC12c	--	2,250.00
		<u>Monthly Rate Per Mile</u>
(7) Custom Connect - Shared Transport		
DS1	--	\$12.00
DS3 / STS1	--	23.00
OC3 / OC3c	--	195.00
OC12 / OC12c	--	420.00
(8) Custom Connect - Dedicated Transport		
OC3 / OC3c	--	155.00
OC12 / OC12c	--	225.00

Effective: April 1, 2016

---

FACILITIES BASED SERVICES  
(LOCAL, INTRASTATE ACCESS AND INTRALATA TOLL)

V. RATES AND CHARGES (Continued)

B. Intrastate Access Services (Continued)

2. High Capacity Facilities (Continued)

Monthly  
Rate

c. Optical Networking (SONET) Facilities (Continued)

(9) Express Connect - Systems

(a) OC3

1) First System

One Year Term	\$7,800.00
Three Year Term	7,150.00
Five Year Term	6,500.00
Seven Year Term	6,400.00

2) Additional System

One Year Term	1,100.00
Three Year Term	1,100.00
Five Year Term	1,100.00
Seven Year Term	1,100.00

(b) OC12

1) First System

One Year Term	13,500.00
Three Year Term	12,100.00
Five Year Term	11,400.00
Seven Year Term	11,300.00

2) Additional System

One Year Term	2,200.00
Three Year Term	2,100.00
Five Year Term	2,100.00
Seven Year Term	2,100.00

Effective: April 1, 2016

---

FACILITIES BASED SERVICES  
(LOCAL, INTRASTATE ACCESS AND INTRALATA TOLL)

V. RATES AND CHARGES (Continued)

B. Intrastate Access Services (Continued)

2. High Capacity Facilities (Continued)

Monthly  
Rate

c. Optical Networking (SONET) Facilities (Continued)

(10) Express Connect - Additional Nodes

(a) OC3

1) Additional CDL Node

One Year Term	\$3,300.00
Three Year Term	3,300.00
Five Year Term	3,300.00
Seven Year Term	3,300.00

2) Additional CO Node

One Year Term	2,200.00
Three Year Term	2,200.00
Five Year Term	2,200.00
Seven Year Term	2,200.00

(b) OC12

1) Additional CDL Node

One Year Term	5,900.00
Three Year Term	5,800.00
Five Year Term	5,450.00
Seven Year Term	5,450.00

2) Additional CO Node

One Year Term	3,425.00
Three Year Term	3,350.00
Five Year Term	3,100.00
Seven Year Term	3,100.00

Effective: April 1, 2016

FACILITIES BASED SERVICES  
(LOCAL, INTRASTATE ACCESS AND INTRALATA TOLL)

V. RATES AND CHARGES (Continued)

B. Intrastate Access Services (Continued)

3. Advanced Data Services

a. TRANSPARENT LAN SERVICE (TLS)

	<u>Nonrecurring Charge</u> <sup>1</sup>	<u>Monthly Rate</u>
(1) Standard Access Line, per line		
(EMS or ERS) UNI Port with Access		
<u>Month-to-Month Option</u> <sup>2</sup>		
10 Mbps	\$1,300.00	\$1,200.00
100 Mbps	1,300.00	2,200.00
1000 Mbps	1,300.00	3,700.00
10 Gbps	1,300.00	11,000.00
<u>Term Commitment Plans</u>		
3 Year Term		
10 Mbps	--	1,000.00
100 Mbps	--	1,800.00
1000 Mbps	--	3,200.00
10 Gbps	--	9,500.00
5 Year Term		
10 Mbps	--	900.00
100 Mbps	--	1,600.00
1000 Mbps	--	2,900.00
10 Gbps	--	8,500.00

<sup>1</sup> See Section 3 of this Product Guide for applicable nonrecurring charges.

<sup>2</sup> The minimum subscription period for the Month-to-Month Option is nine months.

Effective: April 1, 2016

FACILITIES BASED SERVICES  
(LOCAL, INTRASTATE ACCESS AND INTRALATA TOLL)

V. RATES AND CHARGES (Continued)

B. Intrastate Access Services (Continued)

3. Advanced Data Services (Continued)

a. TRANSPARENT LAN SERVICE (TLS) (Continued)

	<u>Nonrecurring Charge</u> <sup>1</sup>	<u>Monthly Rate</u>
(1) Standard Access Line (Continued)		
<b>(EMS) UNI Port with Standard Access – Protected Non-Diverse</b>		
<u>Month-to-Month Option</u> <sup>2</sup>		
10 Mbps	\$1,300.00	\$1,600.00
100 Mbps	1,300.00	2,600.00
1000 Mbps	1,300.00	9,000.00
<u>Term Commitment Plans</u> <sup>3</sup>		
3 Year Term		
10 Mbps	--	1,400.00
100 Mbps	--	2,400.00
1000 Mbps	--	8,000.00
5 Year Term		
10 Mbps	--	1,300.00
100 Mbps	--	2,100.00
1000 Mbps	--	7,000.00
<b>(EMS) UNI Port with Standard Access – Protected Diverse</b>		
<u>Month-to-Month Option</u> <sup>2</sup>		
10 Mbps	\$1,300.00	\$1,900.00
100 Mbps	1,300.00	3,000.00
1000 Mbps	1,300.00	9,500.00
<u>Term Commitment Plans</u> <sup>3</sup>		
3 Year Term		
10 Mbps	--	1,800.00
100 Mbps	--	2,800.00
1000 Mbps	--	8,500.00
5 Year Term		
10 Mbps	--	1,700.00
100 Mbps	--	2,500.00
1000 Mbps	--	7,500.00

<sup>1</sup> Section 3 for applicable nonrecurring charges.

<sup>2</sup> The minimum subscription period for the Month-to-Month Option is nine months.

Effective: April 1, 2016

FACILITIES BASED SERVICES  
(LOCAL, INTRASTATE ACCESS AND INTRALATA TOLL)

V. RATES AND CHARGES (Continued)

B. Intrastate Access Services (Continued)

3. Advanced Data Services (Continued)

a. TRANSPARENT LAN SERVICE (TLS) (Continued)

	<u>Nonrecurring Charge</u> <sup>1</sup>	<u>Monthly Rate</u>
(1) Standard Access Line (Continued)		
<b>(EMS) UNI Port with Standard Access – Protected Private</b>		
<u>Month-to-Month Option</u> <sup>2</sup>		
10 Mbps	\$1,300.00	\$700.00
100 Mbps	1,300.00	900.00
1000 Mbps	1,300.00	2,600.00
<u>Term Commitment Plans</u>		
3 Year Term		
10 Mbps	--	600.00
100 Mbps	--	800.00
1000 Mbps	--	2,400.00
5 Year Term		
10 Mbps	--	500.00
100 Mbps	--	700.00
1000 Mbps	--	2,000.00
(2) (EMS) – Protected Access Line, per line <sup>3</sup>		
<u>Month-to-Month Option</u> <sup>2</sup>		
100 Mbps	N/A	N/A
1000 Mbps	N/A	N/A
<u>Term Commitment Plans</u>		
3 Year Term		
100 Mbps	--	3,000.00
1000 Mbps	--	5,200.00
5 Year Term		
100 Mbps	--	2,700.00
1000 Mbps	--	4,800.00

<sup>1</sup> See Section 3 for applicable nonrecurring charges.

<sup>2</sup> The minimum subscription period for the Month-to-Month Option is nine months.

<sup>3</sup> Effective November 19, 2010, this service will no longer be available to new customers.



Effective: April 1, 2016

FACILITIES BASED SERVICES  
(LOCAL, INTRASTATE ACCESS AND INTRALATA TOLL)

V. RATES AND CHARGES (Continued)

B. Intrastate Access Services (Continued)

3. Advanced Data Services (Continued)

a. TRANSPARENT LAN SERVICE (TLS) (Continued)

	<u>Nonrecurring Charge</u> <sup>1</sup>	<u>Monthly Rate</u>
(3) (EMS) Real Time Access Line		
<b>(EMS) UNI Port with Real Time Access</b>		
<u>Month-to-Month Option</u> <sup>2</sup>		
100 Mbps	\$1,300.00	\$2,500.00
1000 Mbps	1,300.00	4,500.00
10 Gbps	1,300.00	12,500.00
<u>Term Commitment Plans</u> <sup>3</sup>		
3 Year Term		
100 Mbps	--	2,100.00
1000 Mbps	--	4,000.00
10 Gbps	--	11,000.00
5 Year Term		
100 Mbps	--	1,900.00
1000 Mbps	--	3,700.00
10 Gbps	--	10,000.00
<b>(EMS) UNI Port with Real Time Access – Protected Non – Diverse</b>		
<u>Month-to-Month Option</u> <sup>2</sup>		
10 Mbps	N/A	N/A
100 Mbps	1,300.00	2,700.00
1000 Mbps	1,300.00	10,000.00
<u>Term Commitment Plans</u>		
3 Year Term		
10 Mbps	--	N/A
100 Mbps	--	2,500.00
1000 Mbps	--	9,000.00
5 Year Term		
10 Mbps	--	N/A
100 Mbps	--	2,300.00
1000 Mbps	--	8,500.00

<sup>1</sup> See Section 3 for applicable nonrecurring charges.

<sup>2</sup> The minimum subscription period for the Month-to-Month Option is nine months.

Effective: April 1, 2016

FACILITIES BASED SERVICES  
(LOCAL, INTRASTATE ACCESS AND INTRALATA TOLL)

V. RATES AND CHARGES (Continued)

B. Intrastate Access Services (Continued)

3. Advanced Data Services (Continued)

a. TRANSPARENT LAN SERVICE (TLS) (Continued)

	Nonrecurring <u>Charge</u> <sup>1</sup>	Monthly <u>Rate</u>
(3) (EMS) Real Time Access Line (Continued)		
<b>(EMS) UNI Port with Real Time Access – Protected Diverse</b>		
<u>Month-to-Month Option</u> <sup>2</sup>		
10 Mbps	N/A	N/A
100 Mbps	\$1,300.00	\$3,250.00
1000 Mbps	1,300.00	11,000.00
<u>Term Commitment Plans</u>		
3 Year Term		
10 Mbps	--	N/A
100 Mbps	--	3,000.00
1000 Mbps	--	10,000.00
5 Year Term		
10 Mbps	--	N/A
100 Mbps	--	2,750.00
1000 Mbps	--	9,000.00
<b>(EMS) UNI Port with Real Time Access - Protected Private</b>		
<u>Month-to-Month Option</u> <sup>2</sup>		
10 Mbps	N/A	N/A
100 Mbps	1,300.00	950.00
1000 Mbps	1,300.00	2,700.00
<u>Term Commitment Plans</u>		
3 Year Term		
10 Mbps	--	N/A
100 Mbps	--	850.00
1000 Mbps	1,300.00	2,500.00
5 Year Term		
10 Mbps	N/A	N/A
100 Mbps	N/A	750.00
1000 Mbps	N/A	2,100.00

<sup>1</sup> See Section 3 for applicable nonrecurring charges.

<sup>2</sup> The minimum subscription period for the Month-to-Month Option is nine months.

Effective: April 1, 2016

FACILITIES BASED SERVICES  
(LOCAL, INTRASTATE ACCESS AND INTRALATA TOLL)

V. RATES AND CHARGES (Continued)

B. Intrastate Access Services (Continued)

3. Advanced Data Services (Continued)

a. TRANSPARENT LAN SERVICE (TLS) (Continued)

	<u>Nonrecurring Charge</u> <sup>1</sup>	<u>Monthly Rate</u>
(4) ERS – Premier Access Line		
<u>Month-to-Month Option</u> <sup>2</sup>		
10 Mbps	1,300.00	1,075.00
100 Mbps	1,300.00	1,200.00
1000 Mbps	1,300.00	2,400.00
10000 Mbps	1,300.00	10,000.00
<u>Term Commitment Plans</u>		
3 Year Term		
10 Mbps	--	875.00
100 Mbps	--	1,000.00
1000 Mbps	--	2,000.00
10000 Mbps	--	9,000.00
5 Year Term		
10 Mbps	--	775.00
100 Mbps	--	900.00
1000 Mbps	--	1,800.00
10000 Mbps	--	8,000.00
<b>(ERS) UNI Port with Premier Access – Protected Non - Diverse</b>		
<u>Month-to-Month Option</u> <sup>2</sup>		
10 Mbps	1,300.00	1,050.00
100 Mbps	1,300.00	1,900.00
1000 Mbps	1,300.00	7,500.00
<u>Term Commitment Plans</u>		
3 Year Term		
10 Mbps	--	900.00
100 Mbps	--	1,600.00
1000 Mbps	--	7,500.00
5 Year Term		
10 Mbps	--	750.00
100 Mbps	--	1,450.00
1000 Mbps	--	6,500.00

<sup>1</sup> See Section 3 for applicable nonrecurring charges.

<sup>2</sup> The minimum subscription period for the Month-to-Month Option is nine months.

Effective: April 1, 2016

FACILITIES BASED SERVICES  
(LOCAL, INTRASTATE ACCESS AND INTRALATA TOLL)

V. RATES AND CHARGES (Continued)

B. Intrastate Access Services (Continued)

3. Advanced Data Services (Continued)

a. TRANSPARENT LAN SERVICE (TLS) (Continued)

	<u>Nonrecurring Charge</u> <sup>1</sup>	<u>Monthly Rate</u>
(4) ERS – Premier Access Line (Continued)		
<b>(ERS) UNI Port with Premier Access – Protected Diverse</b>		
<u>Month-to-Month Option</u> <sup>2</sup>		
10 Mbps	\$1,300.00	\$1,200.00
100 Mbps	1,300.00	2,150.00
1000 Mbps	1,300.00	9,000.00
<u>Term Commitment Plans</u>		
3 Year Term		
10 Mbps	--	1,000.00
100 Mbps	--	1,800.00
1000 Mbps	--	8,500.00
5 Year Term		
10 Mbps	--	850.00
100 Mbps	--	1,600.00
1000 Mbps	--	8,000.00
<b>(ERS) UNI Port with Premier Access – Protected Private</b>		
<u>Month to Month Plan</u>		
10 Mbps.	1,300.00	600.00
100 Mbps.	1,300.00	700.00
1000 Mbps.	1,300.00	1,700.00
<u>Term Commitment Plans</u>		
Three Year Plan		
10 Mbps.	N/A	500.00
100 Mbps.	N/A	600.00
1000 Mbps.	N/A	1,550.00
Five Year Plan		
10 Mbps	N/A	500.00
1000 Mbps.	N/A	1,400.00

<sup>1</sup> See Section 3 of this Product Guide for applicable nonrecurring charges.

<sup>2</sup> The minimum subscription period for the Month-to-Month Option is nine months.

Effective: April 1, 2016

FACILITIES BASED SERVICES  
(LOCAL, INTRASTATE ACCESS AND INTRALATA TOLL)

V. RATES AND CHARGES (Continued)

B. Intrastate Access Services (Continued)

3. Advanced Data Services (Continued)

a. TRANSPARENT LAN SERVICE (TLS) (Continued)

	<u>Nonrecurring Charge</u> <sup>1</sup>	<u>Monthly Rate</u>
(5) ERS Ethernet Virtual Circuit		
(a) ERS Standard, Premier and EVP-LAN EVC Setup, per EVC	\$200.00	N/A
(b) (ERS) EVC Standard (ERS-Std), per EVC		
10 Mbps	--	\$50.00
100 Mbps	--	100.00
1000 Mbps	--	200.00
(c) (ERS) Premier Basic (ERS-B) Bandwidth, per Class		
1 Mbps	N/A	15.00
2 Mbps	N/A	30.00
3 Mbps	N/A	45.00
4 Mbps	N/A	60.00
5 Mbps	N/A	75.00
6 Mbps	N/A	90.00
7 Mbps	N/A	105.00
8 Mbps	N/A	120.00
9 Mbps	N/A	135.00
10 Mbps	N/A	150.00
20 Mbps	N/A	300.00
30 Mbps	N/A	450.00
40 Mbps	N/A	600.00
50 Mbps	N/A	750.00
60 Mbps	N/A	850.00
70 Mbps	N/A	950.00
80 Mbps	N/A	1,050.00
90 Mbps	N/A	1,150.00
100 Mbps	N/A	1,250.00
200 Mbps	N/A	1,350.00
300 Mbps	N/A	1,450.00
400 Mbps	N/A	1,550.00
500 Mbps	N/A	1,650.00
600 Mbps	N/A	1,740.00
700 Mbps	N/A	1,830.00
800 Mbps	N/A	1,920.00
900 Mbps	N/A	2,010.00
1000 Mbps	N/A	2,100.00

<sup>1</sup> See Section 3 of this Product Guide for applicable nonrecurring charges.

Effective: April 1, 2016

FACILITIES BASED SERVICES  
 (LOCAL, INTRASTATE ACCESS AND INTRALATA TOLL)

V. RATES AND CHARGES (Continued)

B. Intrastate Access Services (Continued)

3. Advanced Data Services (Continued)

a. TRANSPARENT LAN SERVICE (TLS) (Continued)

	<u>Nonrecurring Charge</u> <sup>1</sup>	<u>Monthly Rate</u>
(5) ERS Ethernet Virtual Circuit (Continued)		

(c) (ERS) EVC Premier Priority Data (Priority Data (ERS-PD) Bandwidth, per Class

1 Mbps	N/A	\$40.00
2 Mbps	N/A	80.00
3 Mbps	N/A	120.00
4 Mbps	N/A	160.00
5 Mbps	N/A	200.00
6 Mbps	N/A	220.00
7 Mbps	N/A	240.00
8 Mbps	N/A	260.00
9 Mbps	N/A	280.00
10 Mbps	N/A	300.00
20 Mbps	N/A	600.00
30 Mbps	N/A	900.00
40 Mbps	N/A	1,200.00
50 Mbps	N/A	1,500.00
60 Mbps	N/A	1,720.00
70 Mbps	N/A	1,940.00
80 Mbps	N/A	2,100.00
90 Mbps	N/A	2,300.00
100 Mbps	N/A	2,500.00
200 Mbps	N/A	2,700.00
300 Mbps	N/A	2,900.00
400 Mbps	N/A	3,100.00
500 Mbps	N/A	3,300.00

<sup>1</sup> See Section 3 of this Product Guide for applicable nonrecurring charges.

Effective: April 1, 2016

FACILITIES BASED SERVICES  
(LOCAL, INTRASTATE ACCESS AND INTRALATA TOLL)

V. RATES AND CHARGES (Continued)

B. Intrastate Access Services (Continued)

3. Advanced Data Services (Continued)

a. TRANSPARENT LAN SERVICE (TLS) (Continued)

	<u>Nonrecurring Charge</u> <sup>1</sup>	<u>Monthly Rate</u>
(5) ERS Ethernet Virtual Circuit (Continued)		
(d) (ERS) EVC Premier Real Time (ERS-RT) Bandwidth, per Class		
1 Mbps	N/A	\$120.00
2 Mbps	N/A	240.00
3 Mbps	N/A	360.00
4 Mbps	N/A	480.00
5 Mbps	N/A	600.00
6 Mbps	N/A	660.00
7 Mbps	N/A	720.00
8 Mbps	N/A	780.00
9 Mbps	N/A	840.00
10 Mbps	N/A	900.00
20 Mbps	N/A	1,175.00
30 Mbps	N/A	1,450.00
40 Mbps	N/A	1,725.00
50 Mbps	N/A	2,000.00
60 Mbps	N/A	2,200.00
70 Mbps	N/A	2,400.00
80 Mbps	N/A	2,600.00
90 Mbps	N/A	2,800.00
100 Mbps	N/A	3,000.00

<sup>1</sup> See Section 3 of this Product Guide for applicable nonrecurring charges.

Effective: April 1, 2016

FACILITIES BASED SERVICES  
(LOCAL, INTRASTATE ACCESS AND INTRALATA TOLL)

V. RATES AND CHARGES (Continued)

B. Intrastate Access Services (Continued)

3. Advanced Data Services (Continued)

a. TRANSPARENT LAN SERVICE (TLS) (Continued)

	<u>Nonrecurring Charge</u> <sup>1</sup>	<u>Monthly Rate</u>
(5) ERS Ethernet Virtual Circuit (Continued)		
(e) (ERS) EVP-LAN Basic (EVPLAN-B) Bandwidth, per Class		
1 Mbps	N/A	\$16.00
2 Mbps	N/A	32.00
3 Mbps	N/A	48.00
4 Mbps	N/A	64.00
5 Mbps	N/A	80.00
6 Mbps	N/A	96.00
7 Mbps	N/A	112.00
8 Mbps	N/A	128.00
9 Mbps	N/A	144.00
10 Mbps	N/A	160.00
20 Mbps	N/A	315.00
30 Mbps	N/A	470.00
40 Mbps	N/A	625.00
50 Mbps	N/A	780.00
60 Mbps	N/A	885.00
70 Mbps	N/A	990.00
80 Mbps	N/A	1,200.00
90 Mbps	N/A	1,305.00
100 Mbps	N/A	1,410.00
200 Mbps	N/A	1,515.00
300 Mbps	N/A	1,602.00
400 Mbps	N/A	1,715.00
500 Mbps	N/A	1,810.00
600 Mbps	N/A	1,905.00
700 Mbps	N/A	1,830.00
800 Mbps	N/A	2,000.00
900 Mbps	N/A	2,095.00
1000 Mbps	N/A	2,190.00

<sup>1</sup> See Section 3 of this Product Guide for applicable nonrecurring charges.



Effective: April 1, 2016

FACILITIES BASED SERVICES  
(LOCAL, INTRASTATE ACCESS AND INTRALATA TOLL)

V. RATES AND CHARGES (Continued)

B. Intrastate Access Services (Continued)

3. Advanced Data Services (Continued)

a. TRANSPARENT LAN SERVICE (TLS) (Continued)

	<u>Nonrecurring Charge</u> <sup>1</sup>	<u>Monthly Rate</u>
(5) ERS Ethernet Virtual Circuit (Continued)		
(f) (ERS) EVP-LAN Real Time (EVPLAN-RT) Bandwidth, per Class		
1 Mbps	N/A	\$125.00
2 Mbps	N/A	250.00
3 Mbps	N/A	375.00
4 Mbps	N/A	500.00
5 Mbps	N/A	625.00
6 Mbps	N/A	690.00
7 Mbps	N/A	755.00
8 Mbps	N/A	820.00
9 Mbps	N/A	885.00
10 Mbps	N/A	950.00
20 Mbps	N/A	1,235.00
30 Mbps	N/A	1,520.00
40 Mbps	N/A	1,805.00
50 Mbps	N/A	2,090.00
(6) TLS Domain/LAN		
Extension Equipment Changes, per location, per change	400.00	N/A
(7) Interoffice Mileage, per line		
Per Mile	N/A	100.00
Per Optical Protected Mile	N/A	750.00
Protected Non-Diverse and Protected Diverse Only		
(8) Optional Features		
Customer Service Management (CSM) <sup>2</sup> per Domain/VLAN	350.00	150.00

<sup>1</sup> See Section 3 of this Product Guide for applicable nonrecurring charges.

<sup>2</sup> Effective February 7, 2011 is grandfathered and no longer available to new Customers. Moves, additions or changes to subscribers' existing service will not be permitted.

Effective: April 1, 2016

FACILITIES BASED SERVICES  
(LOCAL, INTRASTATE ACCESS AND INTRALATA TOLL)

V. RATES AND CHARGES (Continued)

C. IntraLATA Toll Services

1. IntraLata Toll Service

a. Business and Residence Rate Schedule

(1) Day Rates

<u>Rate Mileage</u>	<u>Initial Minute (Direct Dialed)</u>	<u>Each Additional Minute</u>
13-16	0.1140	0.0700
17-20	0.1140	0.0700
21-25	0.1360	0.1140
26-30	0.1360	0.1140
31-40	0.1360	0.1140
41-50	0.1470	0.1250
51-70	0.1470	0.1250
71 +	0.1470	0.1360

(2) Evening Rates

<u>Rate Mileage</u>	<u>Initial Minute (Direct Dialed)</u>	<u>Each Additional Minute</u>
13-16	0.0912	0.0560
17-20	0.0912	0.0560
21-25	0.1088	0.0912
26-30	0.1088	0.0912
31-40	0.1088	0.0912
41-50	0.1176	0.1000
51-70	0.1176	0.1000
71 +	0.1176	0.1088

(3) Night and Weekend Rates

<u>Rate Mileage</u>	<u>Initial Minute (Direct Dialed)</u>	<u>Each Additional Minute</u>
13-16	0.0684	0.0420
17-20	0.0684	0.0420
21-25	0.0816	0.0684
26-30	0.0816	0.0684
31-40	0.0816	0.0684
41-50	0.0882	0.0750
51-70	0.0882	0.0750
71 +	0.0882	0.0816

Effective: April 1, 2016

FACILITIES BASED SERVICES  
(LOCAL, INTRASTATE ACCESS AND INTRALATA TOLL)

V. RATES AND CHARGES (Continued)

C. IntraLATA Toll Services (Continued)

1. IntraLata Toll Service (Continued)

b. Operator Handled Rate Schedule

(1) Day Rates

<u>Rate Mileage</u>	<u>Initial Minute (Direct Dialed)</u> <sup>1</sup>	<u>Each Additional Minute</u>
0-12	0.1140	0.0700
13-16	0.1140	0.0700
17-20	0.1140	0.0700
21-25	0.1360	0.1140
26-30	0.1360	0.1140
31-40	0.1360	0.1140
41-50	0.1470	0.1250
51-70	0.1470	0.1250
71 +	0.1470	0.1360

(2) Evening Rates

<u>Rate Mileage</u>	<u>Initial Minute (Direct Dialed)</u> <sup>1</sup>	<u>Each Additional Minute</u>
0-12	0.0912	0.0560
13-16	0.0912	0.0560
17-20	0.0912	0.0560
21-25	0.1088	0.0912
26-30	0.1088	0.0912
31-40	0.1088	0.0912
41-50	0.1176	0.1000
51-70	0.1176	0.1000
71 +	0.1176	0.1088

(3) Night and Weekend Rates

<u>Rate Mileage</u>	<u>Initial Minute (Direct Dialed)</u> <sup>1</sup>	<u>Each Additional Minute</u>
0-12	0.0684	0.0420
13-16	0.0684	0.0420
17-20	0.0684	0.0420
21-25	0.0816	0.0684
26-30	0.0816	0.0684
31-40	0.0816	0.0684
41-50	0.0882	0.0750
51-70	0.0882	0.0750
71 +	0.0882	0.0816

<sup>1</sup> In addition to the Direct Dialed Rate, per message charges for Operator Station-to-Station or Operator Person-to-Person Service are applicable.

Effective: April 1, 2016

FACILITIES BASED SERVICES  
(LOCAL, INTRASTATE ACCESS AND INTRALATA TOLL)

V. RATES AND CHARGES (Continued)

C. IntraLATA Toll Services (Continued)

1. IntraLata Toll Service (Continued)

c. Coin Station Rate Schedule

(1) Day Rates

<u>Rate Mileage</u>	<u>Initial 3-Minute Period (Sent Paid)</u>	<u>Each Additional Minute</u>
13-16	0.3000	0.0500
17-20	0.3000	0.0500
21-25	0.4000	0.1000
26-30	0.4000	0.1000
31-40	0.4000	0.1000
41-50	0.4500	0.1500
51-70	0.4500	0.1500
71 +	0.5000	0.1500

(2) Evening Rates

<u>Rate Mileage</u>	<u>Initial 3-Minute Period (Sent Paid)</u>	<u>Each Additional Minute</u>
13-16	0.2500	0.0500
17-20	0.2500	0.0500
21-25	0.3000	0.1000
26-30	0.3000	0.1000
31-40	0.3000	0.1000
41-50	0.3500	0.1000
51-70	0.3500	0.1000
71 +	0.4000	0.1000

(3) Night and Weekend Rates

<u>Rate Mileage</u>	<u>Initial 3-Minute Period (Sent Paid)</u>	<u>Each Additional Minute</u>
13-16	0.2000	0.0500
17-20	0.2000	0.0500
21-25	0.2500	0.0500
26-30	0.2500	0.0500
31-40	0.2500	0.0500
41-50	0.2500	0.1000
51-70	0.2500	0.1000
71 +	0.3000	0.1000

Effective: April 1, 2016

---

FACILITIES BASED SERVICES  
(LOCAL, INTRASTATE ACCESS AND INTRALATA TOLL)

V. RATES AND CHARGES (Continued)

C. IntraLATA Toll Services (Continued)

1. IntraLata Toll Service (Continued)

d. Operator Handled Service Charges

	<u>Charge Per Message</u>
(1) Credit/Calling Card Calls (Direct Dialed), per message	
(a) Commercial Credit Card <sup>1</sup>	\$0.40
(b) Interexchange Carrier Calling/Credit Card <sup>1</sup>	0.40
(c) Local Exchange Carrier Calling Card	0.40
(2) Operator Handled Station-to-Station	
(a) Direct Dialed	1.00
(b) Coin	0.20
(3) Operator Handled Person-to-Person	
(a) Direct Dialed	3.00
(b) Coin (except COPT Sent Paid)	3.00

<sup>1</sup> Applicable where a contractual arrangement exists between the Company and card issuer.

Effective: April 1, 2016

FACILITIES BASED SERVICES  
 (LOCAL, INTRASTATE ACCESS AND INTRALATA TOLL)

V. RATES AND CHARGES (Continued)

C. IntraLATA Toll Services (Continued)

2. Discount Calling Plans

a. Discount Calling Plan One

(1) Residence

- (a) Monthly Charge - \$1.00 per main billing number.
- (b) Service Order Charges are not applicable.
- (c) Usage Charges are designed to provide a discount for Day, Evening, and Night toll usage.

	<u>Rate</u> <u>Mileage</u>	<u>Initial</u> <u>1-Minute</u>	<u>Each Additional</u> <u>Minute</u>
<u>Day Rate</u>	0-12	0.0969	0.0595
	13-16 <sup>1</sup>	0.0969	0.0595
	17-20	0.0969	0.0595
	21-25	0.1156	0.0969
	26-30	0.1156	0.0969
	31-40	0.1156	0.0969
	41-50	0.1250	0.1063
	51-70	0.1250	0.1063
	71+	0.1250	0.1156
<u>Evening Rate</u>	0-12	0.0775	0.0476
	13-16 <sup>1</sup>	0.0775	0.0476
	17-20	0.0775	0.0476
	21-25	0.0925	0.0775
	26-30	0.0925	0.0775
	31-40	0.0925	0.0775
	41-50	0.1000	0.0850
	51-70	0.1000	0.0850
	71+	0.1000	0.0925
<u>Night Rate</u>	0-12	0.0581	0.0357
	13-16 <sup>1</sup>	0.0581	0.0357
	17-20	0.0581	0.0357
	21-25	0.0694	0.0581
	26-30	0.0694	0.0581
	31-40	0.0694	0.0581
	41-50	0.0750	0.0638
	51-70	0.0750	0.0638
	71+	0.0750	0.0694

<sup>1</sup> Local, EAS and ZUM Zone 3 calls are not included.

Effective: April 1, 2016

FACILITIES BASED SERVICES  
(LOCAL, INTRASTATE ACCESS AND INTRALATA TOLL)

V. RATES AND CHARGES (Continued)

C. IntraLATA Toll Services (Continued)

2. Discount Calling Plans (Continued)

b. Netbook Offer <sup>1</sup>

(1) Residence

Usage Charges: Usage Charges for Netbook Offer are designed to provide an initial one-hour block of time and additional minutes of use each at a flat rate.

Rates: Day, Evening, Night

	<u>Monthly Rate</u> <sup>2</sup>	<u>Each Additional Minute</u> <sup>3</sup>
Netbook Offer	\$6.00	\$0.10

c. Calling Solutions

(1) Residence

	<u>Nonrecurring Charge</u>	<u>Monthly Rate</u>	<u>IntraLATA Toll</u>
(a) Option A	\$7.50	\$11.95	15% <sup>4</sup>
(b) Option B	7.50	19.95	25% <sup>4</sup>
(c) Option C	7.50		
1) Initial Hour, per month	4.98		
2) Additional Minutes, per minute			\$0.10

<sup>1</sup> Netbook Offer is grandfathered and limited to existing customers at existing locations as of January 13, 2005.

<sup>2</sup> The monthly rate includes the first 60 minutes, or fraction thereof, of IntraLATA Toll usage.

<sup>3</sup> Rate applies for any minute, or fraction thereof, in excess of the first 60 minutes of IntraLATA Toll usage in one month.

<sup>4</sup> This percentage represents a discount off of IntraLATA Toll Usage rates.

Effective: April 1, 2016

---

FACILITIES BASED SERVICES  
(LOCAL, INTRASTATE ACCESS AND INTRALATA TOLL)

V. RATES AND CHARGES (Continued)

C. IntraLATA Toll Services (Continued)

2. Discount Calling Plans (Continued)

d. Regional Toll Call Plan - Business <sup>1</sup>

Regional Toll Call Plan - Business is an optional 1+ and 0+ Intrastate IntraLATA IntraLata Toll Service offered only to business customers. The discounts offered with Regional Toll Call Plan - Business are not available with any other discount calling plan.

Business customers who subscribe to Regional Toll Call Plan - Business will receive the following discounts on all toll usage billed for the month when their monthly toll usage exceeds:

<u>Monthly Toll Usage Volume</u>	<u>Month-to-Month Discount</u>	<u>1 Year Discount</u>	<u>3 Year Discount</u>
\$ 0 - 4.99	0%	5%	10%
\$ 5.00 - 49.99	10%	12%	15%
\$ 50.00 - 99.99	10%	15%	20%
\$100.00 and over	15%	20%	25%

Service Ordering charges are not applicable.

<sup>1</sup> Regional Toll Call Plan - Business is grandfathered and limited to existing customers at existing locations as of January 13, 2005.



Effective: April 1, 2016

---

SHARED PRIVATE LINE SERVICES

TABLE OF CONTENTS

	<u>SHEET NO.</u>
I. GENERAL	
Applicability	1
Territory	1
California Education Initiative	1
II. SPECIAL CONDITIONS	
A. Definition	1
B. General	4
C. Business Shared Private Line	4
D. Packet Network Services – Grandfathered as of February 13, 2004	6
E. Frame Relay Service – Grandfathered as of April 11, 2005	8
III. RATES AND CHARGES	
A. Business Shared Private Line	18
B. Packet Network Services – Grandfathered as of February 13, 2004	19
C. Frame Relay Service – Grandfathered as of April 11, 2005	21

Effective: April 1, 2016

---

SHARED PRIVATE LINE SERVICES

I. GENERAL

APPLICABILITY

Applicable to intraCompany private line services offered to subscribers for sharing with other subscribers.

TERRITORY

Within and among the exchange areas of the Company, as those areas are defined on maps as part of the Company's Product Guide.

CALIFORNIA EDUCATION INITIATIVE

New services provided in this schedule are subject to the Education Initiative Waiver. A credit of up to \$2,000.00 may be used within 24 months after applying to the program. This program is available to Public Schools (K-12), Public Libraries, Community Colleges and/or Private Schools (K-12) that have more than 100 students, are registered with the Department of Education and are within Frontier serving area for the installation and/or monthly rate for the new services. The waiver period will be for a 36 month period beginning November 9, 1994 and ending November 9, 1997.

II. SPECIAL CONDITIONS

A. Definitions

Bit. A binary digit, the smallest unit of information in the binary system of notation.

Burst Rate. The upper bandwidth limit the permanent virtual connection is allowed to send data through the FRS network. The burst rate is limited by the actual physical port access speed.

Call Activity. An optional service which allows a subscriber to System Control Service to access records of calling activity generated from the Business Shared Private Line data switch equipment.

Call Detail. A billing option for all inter-system data calls except Permanent Virtual calls.

Committed Information Rate (CIR). The CIR represents the base-level bandwidth the permanent virtual connection is allowed to send data through the network.

Customer Designated Location (CDL). The geographic location designated by the customer at which an access component of the customer's service is first considered to enter the Company's network.

Data Base Change. A customer-requested redesign of a Business Shared Private Line or an ISDN management system software data base.

Data Circuit Terminating Equipment. The equipment that connects to a customer's access channel so that data packets can be sent.

Dedicated Access. Provides the ability to establish connections to the Packet Switching Network <sup>1</sup> using analog or digital Special Access facilities. Dedicated Access provides the ability to originate and receive calls from other customer location and/or authorized users of this service.

<sup>1</sup> Service is grandfathered and limited to existing customers as of February 13, 2004.

---

SHARED PRIVATE LINE SERVICES

II. SPECIAL CONDITIONS (Continued)

A. Definitions (Continued)

Data Link Connection Identifier (DLCI). The address information contained in the Frame Relay <sup>1</sup> header which conveys to the network how an individual frame should be routed. The DLCI essentially defines to which customer end point a particular frame should be sent.

Fast Select. A call-by-call option which speeds transmissions by sending up to 128 bytes of additional data along with call setup and clearing packets.

Frame. A group of data bits, in a specific format, with a flag at either end to indicate the beginning and end of the frame. The defined format enables network equipment to recognize the meaning and purpose of specific bits.

Frame Relay Port. For Frame Relay Service <sup>1</sup>, the physical entry points for Permanent Virtual Circuits (PVCs). Ports include the electronic equipment used in connecting these service elements to the Frame Relay Network, and enable customers to allocate bandwidth to applications, as needed, at customer designated transmission speeds of between 56 Kbps and 1.544 Mbps.

Frame Relay Service. <sup>2</sup> A fast packet network service that permits the transmission of data at speeds of 56 Kbps to 1.544 Mbps using Permanent Virtual Connections (PVCs).

Kilosegment. One thousand segments.

Local Area Network (LAN). A network permitting the interconnection and intercommunication of a group of computers, primarily for the sharing of resources such as data storage devices and printers.

Logical Channel. A communications channel which allows two -way simultaneous transmission of data packets through the network. No circuit capability is preassigned to a logical channel. Capacity is made available as the data is transmitted. Each permanent virtual connection is one logical channel.

Network Address. An alphanumeric character string used to specify the destination of a data packet.

Network Interface (NI). It is the point of interconnection between Company communications facilities and customer terminal equipment. For Frame Relay Service <sup>2</sup>, it is the point at which a customer's data transmission first enters the network supporting Frame Relay Service.

Node. A geographically-related, marketing-related and service-related cluster of central offices (wire centers) and central office serving areas.

Octet. A group of eight binary digits operated upon as an entity.

<sup>1</sup> Effective April 11, 2005, Frame Relay Service is grandfathered and no longer available to new customers. The service will be withdrawn no later than April 11, 2010. Existing OPP customers may continue their service until their OPP expires or their service is disconnected, whichever occurs first. Existing month-to-month customers may continue their service until April 11, 2010 or until their service is disconnected, whichever occurs first. In the interim, moves, additions, or changes will not be permitted.

---

SHARED PRIVATE LINE SERVICES

II. SPECIAL CONDITIONS (Continued)

A. Definitions (Continued)

Packet. Continuous sequence of binary digits (bits) of information that is processed as a unit. A packet consists of a maximum of 4,096 bits (512 octets) plus additional transmission and error control information. Data is divided into segments for billing purposes. The number of segments contained in a packet depends upon the packet size.

Permanent Virtual Circuit (PVC). A logical channel, defined in software, from one end user location to another. It allows a packet to be sent over a dedicated logical channel without call setup or clearing.

Port. A communications interface through which a customer or user sends data packets. Ports are the physical entry points for Access Lines. Ports include the electronic equipment used in connecting elements to the network.

Port Rearrangement. A customer-requested change in port options, such as, flow control, speed, parity, destination and hold and attention character or change in port connection, such as, moving a port connection from one access line to another.

Priority. A call-by-call option which assigns a preferential ranking to a call for transmitting it before others are processed.

Protocol. A set of conditions for conducting interactions between two or more terminals, hosts or peripherals. These conditions consist of syntax (header structure), semantics (actions and reactions that are supposed to occur) and timing (relative ordering and duration of states and events).

A set of transmission rules. The X.25<sup>1</sup> and X.75<sup>1</sup> protocols are international standards developed by the CCITT that provide the foundation for public packet transmissions.

Public Dial Access. Connections made via Public Dial Access are billed to the called party. Calls made via Public Dial Access will be automatically disconnected by the network when the transmission is idle for ten minutes. The customer will be billed for total connect time.

Segment. A unit of user information consisting of 64 octets or fewer. Billing for Packet Delivery Service is based on the number of segments transmitted within the data field of a packet. The number of segments transmitted within a packet is limited only by the subscribed or negotiated maximum size of the data field of the customer interface.

Statistical Multiplexing. A multiplexing technique in which times lots are dynamically allocated on the basis of need rather than being predetermined. The data is typically transmitted on a first come, first served basis.

System Control. An optional service which permits customer monitoring and customer-interactive management and control of information about data base changes, resources, and port rearrangements.

Virtual Connection. A logical transmission channel established to a network address. The logical channel exists for a period of time until either end of the channel terminates the transmission.

X.25<sup>1</sup> Protocol. An interface between data terminal equipment and data circuit terminating equipment for terminals operating in a packet mode.

<sup>1</sup> Service is grandfathered and limited to existing customers as of February 13, 2004.

Effective: April 1, 2016

---

SHARED PRIVATE LINE SERVICES

II. SPECIAL CONDITIONS (Continued)

B. General

1. Private-line services are offered under this schedule on a shared basis only.
2. Shared private-line services include transport between or among central offices (wire centers), bridging, and conditioning but do not include access (local loop) to the private-line services. Access to shared services is offered by the Company through other schedules on an exclusive-use basis and in accordance with the conditions of this and other schedules. Frame Relay Service <sup>1</sup> requires a local loop.
3. A shared private-line service may require equipment compatible with the service to be located at the customer premises. Equipment located on a customer's premises must be provided by the customer.
4. Protection from unauthorized use of a service offered through this Product Guide and from unauthorized access to information accessible through the services provided with respect to this Product Guide is not the responsibility of the Company. Passwords and access codes must be determined or obtained, distributed, and protected by each customer. Liability limitations set forth in other Schedules are also applicable.
5. The Company will not provide customer-requested temporary disconnections or temporary suspensions of shared private-line services. The Company, however, may temporarily suspend or disrupt service for emergency reasons.

C. Business Shared Private Line <sup>2</sup>

1. Business Shared Private Line Nodes - LATA 5

<u>Nodes</u>	<u>Central Offices</u>
Ventura	CMRLXF OXNRXF THOKXF NWPKXF
West Los Angeles	WLANXF WLANXH WLANXJ WLANXG SNMNXG SNMNXJ PDRYXF CLCYXG

<sup>1</sup> Effective April 11, 2005, Frame Relay Service is grandfathered and no longer available to new customers. The service will be withdrawn no later than April 11, 2010. Existing OPP customers may continue their service until their OPP expires or their service is disconnected, whichever occurs first. Existing month-to-month customers may continue their service until April 11, 2010 or until their service is disconnected, whichever occurs first. In the interim, moves, additions, or changes will not be permitted.

<sup>2</sup> Connection to Business Shared Private Line will be provided from any of the central offices listed in these conditions on or within six months of May 19, 1992.

Effective: April 1, 2016

---

SHARED PRIVATE LINE SERVICES

II. SPECIAL CONDITIONS (Continued)

C. Business Shared Private Line<sup>1</sup> (Continued)

1. Business Shared Private Line Nodes - LATA 5 (Continued)

<u>Nodes</u>	<u>Central Offices</u>
Long Beach	BLFLXF LNBHXS LNBHGX LNBHXH LNBHXL LNBHXF LNBHXT LNBHXM SLBHXF WMNSXF DWNYXG DWNYXF NRWLXF
Ontario	ONTRXF POMNXF BLPKXF COVNXF CLMTXF

2. Business Shared Private Line Nodes - LATA 10

<u>Nodes</u>	<u>Central Offices</u>
Santa Barbara	SNBBXF ELWDXF GOLTXF SNBBXG
Santa Maria	SNTMXF

<sup>1</sup> Connection to Business Shared Private Line will be provided from any of the central offices listed in these conditions on or within six months of May 19, 1992.

Effective: April 1, 2016

---

SHARED PRIVATE LINE SERVICES

II. SPECIAL CONDITIONS (Continued)

C. Business Shared Private Line<sup>1</sup> (Continued)

3. Business Shared Private Line transport services permit internodal and intranodal transport of data.
4. Access to Business Shared Private Line transport requires subscription to a Basic Exchange Access Line service (Section 4 of this Product Guide) or to a special access line.
5. Inbound Modem Service and Outbound Modem Service require telephone numbers to which exchange network calls are charged. An exchange telephone number, associated with an exchange selected by the customer, will be assigned to each modem service and the subscriber will be billed the rates and charges associated with Remote Call Forwarding<sup>2</sup>, as specified in Section 6 of this Product Guide. The subscriber will be responsible for all local, ZUM, and message toll calling rates and charges.
6. Business Line 800 Service may be provided with Inbound Modem Service in accordance with the rates, charges, terms, and conditions of Section 30 of this Product Guide.
7. The maximum transmission rate for Asynchronous Access Termination is 19.2 Kilobits per second (Kbps) and the maximum for Synchronous is 9.6 Kbps. Because of variations in customer application, speeds may average slower than the indicated maximums.

D. Packet Network Services<sup>3</sup>

Packet Network Services are data transport services based on CCITT (Consultative Committee on International Telegraph and Telephony) X.25 protocol and the X.75 internetworking protocol. Packet Network Services are available where facilities and conditions permit.

Packet Network Services will allow ISDN customers to transmit data packets outside business customer groups to locations within a LATA, at rates specified in this schedule.

Usage will be billed according to the billing cycle in which the transmissions occur.

<sup>1</sup> Connection to Business Shared Private Line will be provided from any of the central offices listed in these conditions on or within six months of May 19, 1992.

<sup>2</sup> Effective November 16, 2013, residence Remote Call Forwarding Service is no longer available for purchase. Existing customers of record may retain these services at existing locations in accordance with the terms and conditions described herein. Service is not offered for new installations, moves, changes, or additions.

<sup>3</sup> Service is grandfathered and limited to existing customers as of February 13, 2004.

Effective: April 1, 2016

---

SHARED PRIVATE LINE SERVICES

II. SPECIAL CONDITIONS (Continued)

D. Packet Network Services<sup>1</sup> (Continued)

All call attempts and completions will be billed except those blocked or terminated because of network failure or congestion.

Under the Transaction Plan, rates are applied to each fifteen-second interval or portion thereof. Data transmissions lasting longer than fifteen-seconds will be charged overtime in fifteen-second increments at the overtime rate. Any portion of a fifteen-second interval, per call, will be billed as an entire fifteen seconds.

Under the Basic Plan, rates are applied both to minutes-of-use and to kilosegments transmitted. Usage will be rated at the 8:00 a.m. to 5:00 p.m. rate for any portion of a call completed during that rate period and at the 5:00 p.m. to 8:00 a.m. rate for any portion of a call completed during that period or during a holiday. Any portion of a minute, per call, will be billed as a whole minute. Segments will be accumulated during the month and any fraction of a kilosegment will be billed as a whole kilosegment.

Under the High Volume Plan, rates are applied both to minutes-of-use and to kilosegments transmitted. Rates for kilosegments will be discounted according to volume. Usage will be rated at the 8:00 a.m. to 5:00 p.m. rate for any portion of a call completed during that rate period and at the 5:00 p.m. to 8:00 a.m. rate for any portion of a call completed during that period or during a holiday. Any portion of a minute, per call, will be billed as a whole minute. Segments will be accumulated during the month and any fraction of a kilosegment will be billed as a whole kilosegment.

Under the Permanent Virtual High Volume Plan, rates are applied both to minutes-of-use and to kilosegments transmitted. Rates for kilosegments will be discounted according to volume. Usage will be rated at the 8:00 a.m. to 5:00 p.m. rate for any portion of a call completed during that rate period and at the 5:00 p.m. to 8:00 a.m. rate for any portion of a call completed during that period or during a holiday. Any portion of a minute, per call, will be billed as a whole minute. Segments will be accumulated during the month and any fraction of a kilosegment will be billed as a whole kilosegment.

Public Dial Access provides the ability for an authorized user to originate reverse charge calls to a Packet Switching Network Service customer from the Public Switched Network. Public Dial Access requires the customer and/or authorized user to furnish a modem compatible with those provided in the packet network. A modem capability chart based on access type, speed, and protocol will be available upon request. Data transmission is asynchronous at speeds of 300, 1200, or 2400 bps. Public Dial Access is attained when an authorized user dials a seven-digit number to access the Packet Switching Network from the Public Switched Network. Public Dial Access users may originate, but not receive, calls over the Packet Switching Network.

Dedicated Access, available where facilities and conditions permit, provides the ability to establish connections to the Packet Switching Network using analog or digital Special Access facilities. Connection is made at the nearest Local Packet Switching office at a dedicated access port. Each access port has a unique fourteen-digit network address. The access ports will interface with analog or digital channels at speeds of 1.2, 2.4, 4.8, 9.6, 56, or 64 Kbps. The customer must specify the required transmission speed. Dedicated Access requires the customer and/or authorized user to furnish a modem or Data Service Unit / Channel Service Unit (DSU/CSU) compatible with those provided in the network. Dedicated Access provides the ability to originate and receive calls from other customer locations and/or authorized users of this service.

<sup>1</sup> Service is grandfathered and limited to existing customers as of February 13, 2004.



Effective: April 1, 2016

---

SHARED PRIVATE LINE SERVICES

II. SPECIAL CONDITIONS (Continued)

E. Frame Relay Service<sup>1</sup>

1. General

- a. Frame Relay Service (FRS) is a "fast packet" network service that permits the two-way transmission of data at speeds from 56 Kbps to 1.544 Mbps using Permanent Virtual Circuits (PVCs).
- b. Permanent Virtual Circuits (PVCs) are logical circuits that define a specific path for data sent by the customer to another customer location. These circuits are virtual because they are established in software tables and do not tie up capacity when not in use. This also allows multiple PVCs to be defined over a single access line, thereby providing a single access line the capability to transmit data to multiple destinations.
- c. In operation of Frame Relay Service, Customer Premises Equipment (CPE), such as routers, encapsulate arriving data into variable length frames. These frames contain information identifying which PVC in the network should be used to forward the frame to the proper destination. The CPE then sends the frame into the Frame Relay network. The Frame Relay switch reads identifying information and routes the frame to the proper destination based on a pre-established PVC.
- d. The statistical multiplexing Frame Relay switches are able to provide shared network resources to end users of this service.
- e. Frame Relay Service conforms to Consultative Committee for International Telegraph and Telephone (CCITT) and American National Standards Institute (ANSI) standards.
- f. Frame Relay Service, as provided for in this Product Guide section, is offered for intraLATA use only.
- g. The terms, conditions and rates specified herein are in addition to the applicable terms, conditions and rates specified in other sections of this Product Guide and other tariffs of the Company.
- h. The rates and charges set forth for Frame Relay Service provide for the furnishing of service where suitable facilities are available.
- i. The Committed Information Rate (CIR) and Burst Rate are traffic management parameters that allow the customer to fine tune implementation of Frame Relay Service.
- j. Optional Payment Plan (OPP) arrangements are available.

<sup>1</sup> Effective April 11, 2005, Frame Relay Service is grandfathered and no longer available to new customers. The service will be withdrawn no later than April 11, 2010. Existing OPP customers may continue their service until their OPP expires or their service is disconnected, whichever occurs first. Existing month-to-month customers may continue their service until April 11, 2010 or until their service is disconnected, whichever occurs first. In the interim, moves, additions, or changes will not be permitted.

Effective: April 1, 2016

---

SHARED PRIVATE LINE SERVICES

II. SPECIAL CONDITIONS (Continued)

E. Frame Relay Service<sup>1</sup> (Continued)

2. Terms and Conditions

- a. Frame Relay is a transport service that facilitates the exchange of variable length information units (frames) between end user connections by way of PVCs. Each frame is passed to the Frame Relay Network with an address that specifies the virtual connection. Frame Relay service is furnished where facilities and operating conditions permit, and technically feasible.
- b. Variable frame length capability is useful in communications between asynchronous Local Area Networks (LAN) and for transport of synchronous data traffic. Frame Relay is capable of handling the requirements of bursty data sources because of the ability of the service to allocate additional bandwidth when not in use by other sources.
- c. Frame Relay is provided to the customer in the form of Frame Relay Port, which does not include access to the network. The local access component, which provides the customer access to the customer's serving central office is provided from the Facilities for Intrastate Access Tariff C-1. Frame Relay Service Ports are provided for digital special access line connections to the network supporting Frame Relay Service.
- d. The actual throughput of aggregated PVC bandwidths in use at the same time on the same port cannot exceed the port speed.

Since all PVCs are typically not in use at the same time, it is possible for the total bandwidth of all PVCs associated with one Frame Access Line to exceed the bandwidth of that Frame Access Line. This relationship is referred to as over-subscription and when this occurs, there can be no guarantee that the bandwidth defined for that PVC will be available at any point in time.

No PVC or DLCI can have a greater bit rate than the bit rate of the associated Access Line.

The PVC must be associated with at least one Frame Relay Port. A Frame Relay Port can be associated with multiple PVCs.

A customer subscribing to a PVC will be referred to as the Controller of the Frame Relay Port. A Customer may request data transmission capability to another customer. Both customers must have a Frame Relay Access Line and Frame Relay Port. The Controller of each Frame Relay Access Line must have written permission from the other Controller for this data transmission capability.

The Frame Port and PVC are ordered and billed independently and can have different customers as Controllers. A request by one customer to discontinue PVC does not result in the disconnection of the Frame Access Line and Port. Only the Controller of a Frame Access Line may authorize a disconnect of that Frame Relay Port and Access Line.

<sup>1</sup> Effective April 11, 2005, Frame Relay Service is grandfathered and no longer available to new customers. The service will be withdrawn no later than April 11, 2010. Existing OPP customers may continue their service until their OPP expires or their service is disconnected, whichever occurs first. Existing month-to-month customers may continue their service until April 11, 2010 or until their service is disconnected, whichever occurs first. In the interim, moves, additions, or changes will not be permitted.

Effective: April 1, 2016

---

SHARED PRIVATE LINE SERVICES

II. SPECIAL CONDITIONS (Continued)

E. Frame Relay Service<sup>1</sup> (Continued)

2. Terms and Conditions (Continued)

- e. The Company does not undertake to originate data, but offers the use of its service components, where available, to customers for the purpose of transporting customer-originated data.
- f. At service subscription, the customer must specify the Committed Information Rate (CIR) and the Burst Rate for each PVC ordered.
- g. Error correction is the responsibility of the customer's Frame Relay terminal equipment. When the FRS network is congested, customer data that exceeds the CIR ordered at service subscription may be discarded. The FRS nodes will discard frames with errors.

3. Obligations of the Customer

- a. The customer's Frame Relay terminal equipment has the responsibility for retransmitting frames which are discarded due to errors or network congestion.
- b. Where Frame Relay Service is available for use in connection with communications systems or equipment provided by a customer or user, the operating characteristics of such systems or equipment shall be such as not to interfere with any services offered by the Company. Such use is subject to the further provisions that the equipment provided by the customer or user does not endanger the safety of the Company's employees or the public; damage, harm, require change in or alteration of the equipment or other services of the Company; interfere with the proper operation of the Company's equipment or otherwise injure the public in its use of the Company's services. Upon notice from the Company that the equipment provided by the customer or user is causing, or is likely to cause, such hazard or interference, the customer shall take such steps as shall be necessary to remove or prevent such hazard or interference.
- c. The customer, upon request, shall furnish such information as may be required to permit the Company to design and maintain the Frame Relay Service it offers and to assure that the service arrangement is in compliance with the terms and conditions contained herein.
- d. It shall be the responsibility of the customer to ensure the continuing compatibility of the customer-provided equipment that is used in conjunction with the Frame Relay Service. The CPE shall be in compliance with the terms and conditions specified in this Product Guide.
- e. The customer shall be responsible for obtaining permission for the Company's agents or employees to enter the premises of the customer at any reasonable hour for the purpose of installing, inspecting, repairing, or, upon termination of the service, removing the service components of the Company.
- f. The customer shall be responsible for the payment of nonrecurring charges as found in Section 3 of this Product Guide.

<sup>1</sup> Effective April 11, 2005, Frame Relay Service is grandfathered and no longer available to new customers. The service will be withdrawn no later than April 11, 2010. Existing OPP customers may continue their service until their OPP expires or their service is disconnected, whichever occurs first. Existing month-to-month customers may continue their service until April 11, 2010 or until their service is disconnected, whichever occurs first. In the interim, moves, additions, or changes will not be permitted.

Effective: April 1, 2016

---

SHARED PRIVATE LINE SERVICES

II. SPECIAL CONDITIONS (Continued)

E. Frame Relay Service<sup>1</sup> (Continued)

4. Obligations of the Company

- a. The responsibility of the Company shall be limited to furnishing network equipment suitable for Frame Relay Service and to the maintenance and operation of such equipment in a manner proper for such service. Subject to this responsibility, the Company shall not be responsible for the through transmission of signals generated by the customer-provided equipment or system, or for the quality of, or defects in, such transmission or the reception of signals by such equipment or systems.
- b. The Company shall not be responsible for installation, operation or maintenance of any terminal equipment, data unit or communications system provided by a customer or user. The Company is not responsible for adapting Frame Relay Service to the technological requirements of any specific customer equipment.
- c. When a customer orders Frame Relay Service which is relayed to other Local Exchange Carriers, Interexchange Carriers or other Frame Relay networks, the Company will provide advisory assistance as a part of the establishment of this service.
- d. The Company shall not be responsible to the customer or user if changes in any of the equipment, operations or procedures of the Company used in the provision of Frame Relay Service render any facilities provided by the customer or user obsolete or require modification or alteration of such equipment or system or otherwise affect its use or performance, provided the Company has met any applicable information disclosure requirements otherwise required by law.
- e. The Company undertakes the responsibility to maintain and repair the service which it furnishes. Network equipment installed by the Company on the customer's premises shall be and remain the property of the Company. The customer or user may not rearrange, disconnect, remove, attempt to repair, remote test, or interface with any network equipment installed by the Company without prior written consent by the Company.
- f. The Company, by written notice to the customer, may immediately discontinue the furnishing of Frame Relay Service without incurring liability upon nonpayment of any sum due to the Company or a violation of any condition governing the furnishing of service.
- g. The Company has the service responsibility up to and including the network interface.

<sup>1</sup> Effective April 11, 2005, Frame Relay Service is grandfathered and no longer available to new customers. The service will be withdrawn no later than April 11, 2010. Existing OPP customers may continue their service until their OPP expires or their service is disconnected, whichever occurs first. Existing month-to-month customers may continue their service until April 11, 2010 or until their service is disconnected, whichever occurs first. In the interim, moves, additions, or changes will not be permitted.

---

SHARED PRIVATE LINE SERVICES

II. SPECIAL CONDITIONS (Continued)

E. Frame Relay Service<sup>1</sup> (Continued)

5. Terms and Conditions

- a. A customer may access Frame Relay Service (FRS) via Company-provided digital private line facilities. The associated terms, conditions, rates and charges for private line facilities shall apply in addition to applicable rates and charges associated with the FRS elements as well as applicable nonrecurring charges from Section 3 of this Product Guide.
- b. The total number of Frame Relay PVCs purchased determines the rate category for all PVCs. For example, if 15 PVCs are subscribed, then all PVCs will be rated at the monthly rate for 11 to 20 PVCs since 15 falls into that range.
- c. When a customer subsequently orders additional PVCs, the sum total of all PVCs subscribed to by the Customer shall be used to determine the customer's PVC monthly rate category for all PVCs then subscribed.
- d. When a customer orders additional PVCs or changes PVC assignments on a given FRS port after the initial port installation, the Frame Relay PVC nonrecurring charge shall apply.
- e. Service Rearrangements

Service rearrangements are changes to existing (installed) services which do not result in a change in the physical location of the network interface. (Changes in the physical location of the network interface are treated as moves and are described and charged for as set forth herein.)

(1) Additions to Service

- (a) With the exception of PVCs, when service elements are added to an existing service, the added elements must meet the minimum period requirements associated with the service to which they are added.
- (b) When PVCs are added to an existing Frame Relay Service, the minimum period for the added PVCs is one month.
- (c) With the exception of PVCs, an addendum to the existing fixed-period service agreement is required when service elements are added to an existing fixed-period service. PVCs may be added to existing fixed-period service on a month-to-month basis without an addendum to the existing fixed-period service agreement.
- (d) Nonrecurring charges will apply for all additions to existing services, service elements, or optional features for which nonrecurring charges normally apply at installation.

<sup>1</sup> Effective April 11, 2005, Frame Relay Service is grandfathered and no longer available to new customers. The service will be withdrawn no later than April 11, 2010. Existing OPP customers may continue their service until their OPP expires or their service is disconnected, whichever occurs first. Existing month-to-month customers may continue their service until April 11, 2010 or until their service is disconnected, whichever occurs first. In the interim, moves, additions, or changes will not be permitted.

Effective: April 1, 2016

---

SHARED PRIVATE LINE SERVICES

II. SPECIAL CONDITIONS (Continued)

E. Frame Relay Service<sup>1</sup> (Continued)

5. Terms and Conditions (Continued)

e. Service Rearrangements (Continued)

(1) Additions to Service (Continued)

- (e) Nonrecurring charges for additional PVCs will be required if PVCs are not purchased with a Frame Relay Port at the time of the original service request.
- (f) Related monthly rates and nonrecurring charges for addition(s) to service are the rates and charges in effect at the time of the addition(s).

(2) Upgrades in Speed or Capacity

- (a) Should the customer upgrade either a portion or the entire service provided under a fixed-period service agreement to a higher speed or greater capacity, discontinuance charges will not apply, provided all the following conditions are met:
  - Both the existing and new services and/or service element(s) are of the same service type; e.g., both Frame Relay Service;
  - Both the existing and the new services and/or service element(s) are provided solely by the Company;
  - The order to discontinue a service at an existing speed or capacity and the order for the upgraded service are received by the Company at the same time;
  - The new service will be provided at the same customer location as the discontinued service;
  - The fixed-period plan for the upgraded service(s) and/or service element(s) meets or exceeds the remaining length of the existing fixed-period plan; and
  - The total monthly rate of the new agreement is equal to or greater than the total monthly rate of the existing agreement period.
- (b) The monthly rates for the upgraded services and/or service elements will be those rates in effect at the time of the service upgrade. The related nonrecurring charges which apply for the upgrade are the charges in effect at the time of the service upgrade.
- (c) Should the order to upgrade exclude one or more of the conditions listed above under "Upgrades in Speed or Capacity," it will be treated as a discontinuance of the existing service and the establishment of a new service. All outstanding minimum period charges and discontinuance charges will apply.

<sup>1</sup> Effective April 11, 2005, Frame Relay Service is grandfathered and no longer available to new customers. The service will be withdrawn no later than April 11, 2010. Existing OPP customers may continue their service until their OPP expires or their service is disconnected, whichever occurs first. Existing month-to-month customers may continue their service until April 11, 2010 or until their service is disconnected, whichever occurs first. In the interim, moves, additions, or changes will not be permitted.

Effective: April 1, 2016

---

SHARED PRIVATE LINE SERVICES

II. SPECIAL CONDITIONS (Continued)

E. Frame Relay Service<sup>1</sup> (Continued)

5. Terms and Conditions (Continued)

e. Service Rearrangements (Continued)

(3) Administrative Changes (Continued)

Administrative changes to existing service will be made without charge(s) to the customer.  
Administrative changes are as follows:

- Change of customer name, i.e., the customer or record does not change but rather the customer of record changes its name, e.g., XYZ Company to XYZ Communications,
- Change of customer premises address when the change of address is not a result of a physical relocation of facilities,
- Change in billing data (name, address, or contact name or telephone number),
- Change of customer contact name or telephone number, and
- Change of customer service element identification.

6. Discounts for Qualifying Entities

See General Exchange Tariff, Schedule No. K-8 for qualifications and discounts for Schools, Libraries, Health Care Providers, and Community Based Organizations.

7. Frame Relay Port

A nonrecurring charge and a monthly rate, based on the speed of the port connection (i.e., 56 Kbps to 1.544 Mbps) apply per port for each Frame Relay Access Line or digital private line connection to the network supporting FRS. Each port includes one PVC and can accommodate multiple PVCs. For Access Line, see the Facilities for Intrastate Access Tariff C-1.

8. Data Link Connection Identifier (DLCI)

A nonrecurring charge and a monthly rate apply for each PVC. PVCs are accumulated on a per port basis. A nonrecurring charge applies for each subsequent order of PVC's change on an existing FRS.

<sup>1</sup> Effective April 11, 2005, Frame Relay Service is grandfathered and no longer available to new customers. The service will be withdrawn no later than April 11, 2010. Existing OPP customers may continue their service until their OPP expires or their service is disconnected, whichever occurs first. Existing month-to-month customers may continue their service until April 11, 2010 or until their service is disconnected, whichever occurs first. In the interim, moves, additions, or changes will not be permitted.

Effective: April 1, 2016

---

SHARED PRIVATE LINE SERVICES

II. SPECIAL CONDITIONS (Continued)

E. Frame Relay Service <sup>1</sup> (Continued)

9. Customer Network Management (CNM) <sup>2</sup>

A customer may link to the Frame Relay network management system and obtain visibility to their portion of the network. CNM will allow the customer to obtain real time status and performance information such as PVC availability, number of discarded frames, utilization and related data. The customer must have a SNMP based management system. The customer only needs to purchase one CNM to manage their entire FRS network.

10. Rate Application

A customer may access Frame Relay Service via Company provided digital special access facilities offered from the Facilities for Intrastate Access Tariff C-1. When a customer utilizes a special access line to access FRS, the associated terms, conditions, rates and charges for such facilities shall apply in addition to the rates and charges associated with the FRS rate elements.

A customer utilizing special access facilities to access FRS would incur the monthly rate and nonrecurring charge associated with the Frame Relay Port charges as set forth under III.C.1.a.

When a customer orders additional PVCs or changes PVC assignments on a Frame Relay port after the initial port installation, the Frame Relay PVC nonrecurring charge shall apply per PVC added or changed.

The Subsequent Activity Charge is applicable anytime a customer makes a change to the port termination speed and there is no change to the access link. Changing the speed of the access link will incur an installation charge for the new access link and an installation charge for the new port termination.

The Frame Relay Port and PVC are ordered and billed independently and can have different Controllers, as discussed in II.E.2.d. A request by one customer to discontinue a PVC does not result in the disconnection of the Frame Relay Port. Only the Controller of a Frame Relay Port may authorize a disconnect of that line.

<sup>1</sup> Effective April 11, 2005, Frame Relay Service is grandfathered and no longer available to new customers. The service will be withdrawn no later than April 11, 2010. Existing OPP customers may continue their service until their OPP expires or their service is disconnected, whichever occurs first. Existing month-to-month customers may continue their service until April 11, 2010 or until their service is disconnected, whichever occurs first. In the interim, moves, additions, or changes will not be permitted.

<sup>2</sup> Available where technically feasible after October 31, 1994.



Effective: April 1, 2016

---

SHARED PRIVATE LINE SERVICES

II. SPECIAL CONDITIONS (Continued)

E. Frame Relay Service<sup>1</sup> (Continued)

11. Optional Payment Plan (OPP)

a. General

- (1) Three- and five-year OPP monthly rates will be equal to or less than the one-year OPP rates. Decreases to the one-year OPP will flow through to the three- and five-year OPP.
- (2) Payment periods of one year, three years, and five years are available to all customers at the applicable rates set forth in the Rates section regardless of when they subscribe to an OPP arrangement.
- (3) The customer must designate on the order the payment period for the OPP.
- (4) PVCs are not available on an OPP.

b. Changes in Length of OPP Period

Prior to the completion of the selected OPP period, the customer may elect to convert to a new OPP period of the same or different length, subject to the following conditions:

- No credit toward the new payment period will be given for payments made under the original OPP arrangement.
- Nonrecurring charges will not be reapplied for existing service(s).
- If the new OPP period is shorter in length than the time remaining under the existing OPP, the change to the new OPP period constitutes a disconnect of the existing OPP service and termination liability charges apply.

c. Renewal Options

- (1) At the expiration of an OPP period, the Company will automatically renew the service at the same OPP period unless the customer chooses to convert to a different OPP period, convert to month-to-month rates or discontinue service.
- (2) Conversion to a different OPP period will require the customer to submit a change order. Conversion to a different OPP period will be allowed without application of any nonrecurring or ordering charges.
- (3) Conversion to month-to-month rates will be treated as a disconnect of service and establishment of new service. If no other changes are ordered, only the Initial Ordering Charge will apply per required order.

<sup>1</sup> Effective April 11, 2005, Frame Relay Service is grandfathered and no longer available to new customers. The service will be withdrawn no later than April 11, 2010. Existing OPP customers may continue their service until their OPP expires or their service is disconnected, whichever occurs first. Existing month-to-month customers may continue their service until April 11, 2010 or until their service is disconnected, whichever occurs first. In the interim, moves, additions, or changes will not be permitted.

Effective: April 1, 2016

---

SHARED PRIVATE LINE SERVICES

II. SPECIAL CONDITIONS (Continued)

E. Frame Relay Service<sup>1</sup> (Continued)

11. Optional Payment Plan (OPP) (Continued)

d. Notification of Discontinuance

An Order for discontinuance of an OPP arrangement must be received by the Company at least thirty (30) days prior to actual disconnect of service. Monthly charges will apply for a period of thirty (30) days from the date the Company receives disconnect notification or until the requested disconnect date, whichever period is longer.

e. Upgrade to Higher Speed Service

Customers may elect to upgrade service(s) to a higher speed during an OPP period, subject to the following conditions:

- The upgraded service will be subject to nonrecurring charges.
- Termination liability charges will not apply as long as the upgraded service remains connected at the same point(s) of termination.
- If the upgrade involves establishing a multiplexing arrangement, termination liability charges will not apply if the hub wire center is the same one associated with the customer designated location.

f. Termination Liability

When an OPP service is discontinued prior to the end of the period, termination liability charges, as set forth below, will apply based on the remainder of the OPP period in effect at the time of disconnect.

One Year OPP - 50% of any remaining portion of the first year's recurring charges.

Three Year OPP - 50% of any remaining portion of the first year's recurring charges. In addition, for any remaining portion of the second and third years, the customer will be liable for 10% of the total monthly recurring charges in that time period.

Five Year OPP - 50% of any remaining portion of the first year's recurring charges. In addition, for any remaining portion of the second through fifth years, the customer will be liable for 10% of the total monthly recurring charges in that time period.

g. Termination Without Liability

During an OPP period, should the currently effective rate for a customer's service increase, the customer may, at their option, terminate the OPP arrangement without penalty or liability.

<sup>1</sup> Effective April 11, 2005, Frame Relay Service is grandfathered and no longer available to new customers. The service will be withdrawn no later than April 11, 2010. Existing OPP customers may continue their service until their OPP expires or their service is disconnected, whichever occurs first. Existing month-to-month customers may continue their service until April 11, 2010 or until their service is disconnected, whichever occurs first. In the interim, moves, additions, or changes will not be permitted.

Effective: April 1, 2016

SHARED PRIVATE LINE SERVICES

III. RATES AND CHARGES

	<u>Nonrecurring Charge</u>	<u>Monthly Rate</u>
A. Business Shared Private Line		
1. Shared Transport		
a. Shared Intranodal Transport		
(1) Initial Node		
First port	-	\$1.50
Each additional port	-	1.50
(2) Each Additional Node, per port	-	1.50
b. Shared Intranodal Transport (IntraLATA only)		
Each Additional Node, per port	-	2.50
2. Access Terminations		
a. Asynchronous (Up to 19.2 Kbps), Per port	\$95.00	18.00
b. Synchronous (Up to 9.6 Kbps), Per port	95.00	44.00
c. X.25 9.6 Kbps <sup>1</sup>	95.00	100.00
d. X.25 19.2 Kbps <sup>1</sup>	95.00	130.00
3. Central Office Voice Data Multiplexer, Per unit (C-VDM)	-	9.00

<sup>1</sup> Service is grandfathered and limited to existing customers as of February 13, 2004.

Effective: April 1, 2016

SHARED PRIVATE LINE SERVICES

III. RATES AND CHARGES (Continued)

	<u>Nonrecurring Charge</u>	<u>Monthly Rate</u>
A. Business Shared Private Line (Continued)		
4. Business Shared Private Line Complementary (optional) Services.		
a. System Control Service. Per account.	\$2000.00	\$200.00
b. Call Activity Service. Per port. (Requires subscription to System Control Service)	1.00	0.30
c. Inbound Modem Service. Per modem. 100.00 <sup>1</sup>	25.00 <sup>1</sup>	
d. Outbound Modem Service. Per modem. 100.00 <sup>1</sup>	25.00 <sup>1</sup>	
5. Subsequent Order Activity		
a. Port Rearrangement. Per port.	40.00	
b. Data Base Change. Per line item.	20.00	
B. Packet Network Services <sup>2</sup>		
		<u>Rates</u>
1. Usage - Transactional Plan		
a. Each 15-second or shorter transaction		\$0.010
b. Each 15-second or shorter overtime transaction		0.010
2. Usage - Basic Plan		
a. 8:00 a.m. to 5:00 p.m.		
(1) Per minute or portion thereof		0.015
(2) Per Kilosegment		0.300
b. 5:00 p.m. to 8:00 a.m. and holidays		
(1) Per minute or portion thereof		0.005
(2) Per kilosegment		0.200

<sup>1</sup> Plus rates and charges associated with Remote Call Forwarding.

<sup>2</sup> Packet Network Services are grandfathered and limited to existing customers as of February 13, 2004.

Effective: April 1, 2016

SHARED PRIVATE LINE SERVICES

III. RATES AND CHARGES (Continued)

B. Packet Network Services <sup>1</sup> (Continued)

	<u>Rates</u>
3. Usage - High-Volume Plan	
a. 8:00 a.m. to 5:00 p.m.	
(1) Per minute or portion thereof	\$0.015
(2) Per kilosegment	
(a) 0001 to 2000 kilosegments	0.300
(b) 2001 to 4000 kilosegments	0.270
(c) 4001 to 6000 kilosegments	0.230
(d) More than 6000 kilosegments	0.180
b. 5:00 p.m. to 8:00 a.m. and holidays	
(1) Per minute or portion thereof	0.005
(2) Per kilosegment	
(a) 0001 to 2000 kilosegments	0.300
(b) 2001 to 4000 kilosegments	0.270
(c) 4001 to 6000 kilosegments	0.230
(d) More than 6000 kilosegments	0.180
4. Usage - Basic Permanent Virtual Circuit Plan, per kilosegment	
a. 8:00 a.m. to 5:00 p.m.	0.600
b. 5:00 p.m. to 8:00 a.m. and holidays	0.400
5. Usage - High Volume Permanent Virtual Circuit Plan, per kilosegment	
a. 0001 to 2000 kilosegments	0.600
b. 2001 to 4000 kilosegments	0.500
c. 4001 to 6000 kilosegments	0.400
d. More than 6000 kilosegments	0.300
	<u>Nonrecurring Charge</u>
6. Call Detail, per month	
a. 00 to 49 lines	25.00
b. More than 49 lines	50.00
7. Fast Select, per transaction	0.015
8. Priority, per kilosegment	0.300
9. Public Dial Access <sup>2,3</sup>	4
10. Dedicated Access <sup>3,4,5</sup>	\$125.00      40.00

<sup>1</sup> Packet Network Services are grandfathered and limited to existing customers as of February 13, 2004.

<sup>2</sup> This option required access to the network via an exchange access line this Product Guide.

<sup>3</sup> Where facilities and conditions permit.

<sup>4</sup> Packet Network Services usage charges are applicable.

<sup>5</sup> This option requires private line access.

Effective: April 1, 2016

---

SHARED PRIVATE LINE SERVICES

III. RATES AND CHARGES (Continued)

C. FRAME RELAY SERVICE <sup>1</sup>

1. Frame Relay Service

	<u>Nonrecurring Charge</u>	<u>Monthly Rates</u>
a. Frame Relay Port, each		
56 Kbps		
Month-to-Month	\$125.00	\$70.00
One Year	125.00	65.00
Three Years	125.00	60.00
Five Years	125.00	55.00
128 (2 x 64) Kbps		
Month-to-Month	225.00	80.00
One Year	225.00	75.00
Three Years	225.00	70.00
Five Years	225.00	68.00
256 (4 x 64) Kbps		
Month-to-Month	225.00	115.00
One Year	225.00	110.00
Three Years	225.00	105.00
Five Years	225.00	100.00
384 (6 x 64) Kbps		
Month-to-Month	225.00	145.00
One Year	225.00	140.00
Three Years	225.00	135.00
Five Years	225.00	130.00
1.544 Mbps		
Month-to-Month	225.00	240.00
One Year	225.00	235.00
Three Years	225.00	230.00
Five Years	225.00	225.00

<sup>1</sup> Effective April 11, 2005, Frame Relay Service is grandfathered and no longer available to new customers. The service will be withdrawn no later than April 11, 2010. Existing OPP customers may continue their service until their OPP expires or their service is disconnected, whichever occurs first. Existing month-to-month customers may continue their service until April 11, 2010 or until their service is disconnected, whichever occurs first. In the interim, moves, additions, or changes will not be permitted.

Effective: April 1, 2016

---

SHARED PRIVATE LINE SERVICES

III. RATES AND CHARGES (Continued)

C. FRAME RELAY SERVICE <sup>1</sup> (Continued)

1. Frame Relay Service (Continued)

	<u>Nonrecurring Charge</u>	<u>Monthly Rates</u>
b. Data Link Connection Identifier (DLCI), each		
2 to 10 PVCs	\$10.00	\$8.00
11 to 20 PVCs	10.00	7.00
21 or more PVCs	10.00	6.00
c. Customer Network Management (CNM)	60.00	10.00
d. Subsequent Activity Charge, per Port	10.00	n/a

<sup>1</sup> Effective April 11, 2005, Frame Relay Service is grandfathered and no longer available to new customers. The service will be withdrawn no later than April 11, 2010. Existing OPP customers may continue their service until their OPP expires or their service is disconnected, whichever occurs first. Existing month-to-month customers may continue their service until April 11, 2010 or until their service is disconnected, whichever occurs first. In the interim, moves, additions, or changes will not be permitted.

Effective: April 1, 2016

---

SWITCHED DATA SERVICES

TABLE OF CONTENTS

	<u>SHEET NO.</u>
I. GENERAL	1
II. RATES AND CHARGES	
A. Switched Data Customer Line Services	1
B. Switched Data Optional Services	3
C. Switched Data Optional Service Packages	3
D. Switched Data Network Usage	3
E. Switched Data Software Reconfiguration	3
III. SPECIAL CONDITIONS	
A. Definitions	4
B. Description of Services	5
C. General	7
D. Application of Rates	8
E. Access Dialing	9
F. Technical Limitations	9
G. Service Interruption	9
H. Special Construction	9
I. Discounts for Qualifying Entities	9



Effective: April 1, 2016

SWITCHED DATA SERVICES

I. GENERAL

APPLICABILITY

Applicable to measured-rate, Single Line and Centrex Switched Data Services.

TERRITORY

Within all exchange areas, as those areas are defined by maps filed as part of the General Exchange Tariff, Schedule No. AB.

II. RATES AND CHARGES

	Nonrecurring Charge *	Monthly Rate #
A. <u>Switched Data Customer Line Services@</u>		
1. Low Speed Line Services **		
a. Single Line, without Intercom, each	\$50.00	\$38.00
b. Centrex with Intercom		
2 - 49 lines, each	50.00	38.00
50 - 100 lines, each	50.00	38.00
101 and above lines, each	50.00	38.00
2. High Speed Line Services		
a. Single Line, without Intercom, each	50.00	42.00
b. Centrex with Intercom		
2 - 49 lines, each	50.00	42.00
50 - 100 lines, each	50.00	42.00
101 and above lines, each	50.00	42.00

# Plus appropriate individual line/trunk rate in the General and Exchange Tariff, Schedule No. A-1.

\* In addition to Service Connection Charges in Section 3.

@ In addition to the FCC Subscriber Line Charge, set forth in Frontier Operating Companies Tariff FCC No. 14, Section 13.

Effective: April 1, 2016

---

SWITCHED DATA SERVICES

II. RATES AND CHARGES (Continued)

A. Switched Data Customer Line Services (Continued)

	<u>Nonrecurring Charge</u> *	<u>Monthly Rate</u> #
3. Switched Data Channel Access, @# (24 channels)	\$300.00	\$270.00
a. Central Office Termination, per access arrangement	125.00	150.00
b. Central Office Channelization, per channel activated		6.00
c. Customer Premises Termination, (optional) per access arrangement	75.00	130.00
d. Customer Premises Channelization (optional) per channel activated	20.00	30.00
4. Switched Data Individual Line Loop Extension Service <sup>1,2</sup>		
a. Single Line Access #	50.00	50.00
Single Line Extension Channel	50.00	12.00
b. Centrex Access #	50.00	50.00
Centrex Extension Channel	50.00	15.00

<sup>1</sup> Both the Access and the Extension Channel are required.

<sup>2</sup> In addition to the Special Transport Rates set forth in the Facilities for Intrastate Access Tariff C-1, Digital Data Service (when applicable).

@ In addition to the 1.544 Mbps Special Transport Rates set forth in the Facilities for Intrastate Access Tariff C-1 (when applicable).

\* In addition to Service Connection Charges in Section 3.

# In addition to the FCC Subscriber Line Charge set forth in Frontier Operating Companies Tariff FCC No. 14, Section 13.

Effective: April 1, 2016

---

SWITCHED DATA SERVICES

II. RATES AND CHARGES (Continued)

	<u>Nonrecurring Charge</u> *	<u>Monthly Rate</u> #
B. <u>Switched Data Optional Services</u> , per line		
1. Data Direct Connect		\$1.00
2. Data Closed User Group		1.00
3. Voice Option		5.00
a. Single Line, each		
b. Centrex Line, each		
C. <u>Switched Data Optional Service Packages</u>		
1. Feature Package Data 1000, each		3.00
2. Feature Package Data 2000, each		5.00
D. <u>Switched Data Network Usage</u> @		
Switched Data Network Usage will be billed in accordance with the rates and conditions for local, ZUM, and message toll calls as set forth in the General Exchange Tariff, Schedule Nos. A-1, A-9 and the Facilities for Intrastate Access Tariff C-1.		
E. <u>Switched Data Software Reconfiguration</u> , per occurrence		<u>Rate</u> \$12.75
The Software Reconfiguration charge is applicable for any software changes that are required to make changes to Optional Features (e.g., changing Speed Call Lists, Data Direct Connection Destination, etc.) or changes to Feature Packages (e.g., add, delete or change features). The subsequent order charge will apply.		

\* In addition to Service Connection charges in Section 3.

@ Network usage does not apply to Centrex intercom calls.

---

SWITCHED DATA SERVICES

III. SPECIAL CONDITIONS

A. Definitions

Asynchronous. A method of transmitting data in which each transmitted character is preceded by a start bit and followed by a stop bit, thus permitting the interval between characters to vary.

Bit. A binary digit. The smallest unit of information in the binary system of notation.

Bits Per Second (bps). The number of bits transmitted per second. A measure of the speed of transmission of digital information.

Digital. Information which is expressed in discrete or noncontinuous form.

Full Duplex. Type of communication that supports the transmission of signals in both directions simultaneously. This is not associated with simultaneous transmission of voice and data communications.

Half Duplex. Type of communication that supports transmission of data signals alternately in both directions, but is not capable of simultaneous and independent transmission and reception. This is not associated with simultaneous transmission of voice and data communications.

Hunting. A search through a group of telephone numbers until an idle number is found or the last number of the group is reached.

Off-Peak. The Off-Peak period for usage rating is from 5:00 p.m. up to, but not including, 8:00 a.m.

Peak. The peak period for usage rating is from 8:00 a.m. up to, but not including, 5:00 p.m.

Synchronous. A method of transmitting data in which the data characters and bits are transmitting data in which the data characters and bits are transmitted at a fixed rate with the transmitter and receiver synchronized, eliminating the need for individual start bits and stop bits.

Switched Data Services. Exchange network services which provide for digital, end-to-end data transport.

Low Speed Line Services. Low Speed Switched Data service supports 300, 1200, 2400, 4800, 9600 and 19,200 bits per second, asynchronous, full duplex or half duplex connections and 1200, 2400, 4800, 9600 and 19,200 bits per second synchronous full duplex or half duplex connections for single line and Centrex Line applications.

High Speed Line Services. High Speed Line Services support 48,000, 56,000, and 64,000 bits per second synchronous full duplex connections for Single Line and Centrex Line applications.

Switched Data Individual Line Loop Extension Service. An extended loop capability which transports Switched Data usage between the customer premises and the local serving central office. Each Switched Data Individual Line Loop Extension includes one channel which is used exclusively for data transmissions. Some technologies will permit transmissions up to 56,000 bits per second or up to 64,000 bits per second depending on technology.

Effective: April 1, 2016

---

## SWITCHED DATA SERVICES

### III. SPECIAL CONDITIONS (Conditions)

#### B. Description of Services (Continued)

Switched Data Channel Access. A 1.544 high capacity digital facility that transports Switched Data usage between the customer premises and the local serving central office on a channelized basis. Switched Data Channel Access provides 24 digital channels that support data transmission only. On a per channel basis, the customer can transmit data up to 56,000 bits per second.

Data Line Security. Data Line Security prevents a call from being interrupted by override tones, such as a call waiting tone, or other test or busy verification tests that would interrupt the flow of data.

Intercom Dialing. Intercom Dialing allows customer group stations to complete calls to other stations without the assistance of an attendant, by dialing a 2 through 7 digit number. This feature is applicable to Centrex customer groups only and is restricted to the serving wire center only.

Direct Dialing. Direct Dialing allows the user to place local and long distance calls between Switched Data lines without the assistance of an attendant by using the standard 7 through 10 digit dialing methods.

Data Direct Connect. Data Direct Connect is an optional service which provides an automatic connection between a Switched Data calling line that goes off-hook at a predetermined location.

Data Closed User Group. Data Closed User Group is an optional service restricted to Centrex lines, which provide partitioning of Switched Data lines into groups where calls within such a group are allowed, but calls between such groups are denied.

Voice Option. Voice Option is an optional service which allows simultaneous voice and data communications over a single Switched Data line. This feature is available where technical capabilities exist but is not available with Switched Data Channel Access nor with Switched Data Individual Line Loop Extension.

Effective: April 1, 2016

---

SWITCHED DATA SERVICES

III. SPECIAL CONDITIONS (Conditions)

B. Description of Services (Continued)

Bundled Services - Feature Package Data 1000

Data Individual Speed Call-Short List. Individual Speed Call-Short List is limited to an individual Switched Data line. Short List permits up to eight stored numbers. Short List is not available with Switched Data Channel. Access nor with Switched Data Individual Line Loop Extension.

Data Call Forward (All/Busy/No Answer). Data Call Forward permits incoming calls to be automatically forwarded to a predetermined number. All calls may be forwarded or calls can be forwarded according to busy or no answer conditions. Data Call Forward is not available with Switched Data Channel Access nor with Switched Data Individual Line Loop Extension.

Data Last Number Redial. Data Last Number Redial permits redialing the last called number by depressing a single key. Redial is not available with Switched Data Channel Access nor with Switched Data Individual Line Loop Extension.

Data Toll Restriction. Data Toll Restriction will block toll calling over Switched Data Lines.

Data Sequential Hunt Group. Data Sequential Hunt Group pilot telephone number to a group of lines. Hunting is sequential, starting at the first line assigned to the pilot telephone number and ending at the last line.

Voice Option. Voice Option is an optional service which allows simultaneous voice and data communications over a single Switched Data line. This feature is available where technical capabilities exist but is not available with Switched Data Channel Access nor with Switched Data Individual Line Loop Extension.

Bundled Services - Feature Package Data 1000

Data Individual Speed Call-Short List. Individual Speed Call-Short List is limited to an individual Switched Data line. Short List permits up to eight stored numbers. Short List is not available with Switched Data Channel. Access nor with Switched Data Individual Line Loop Extension.

Data Call Forward (All/Busy/No Answer). Data Call Forward permits incoming calls to be automatically forwarded to a predetermined number. All calls may be forwarded or calls can be forwarded according to busy or no answer conditions. Data Call Forward is not available with Switched Data Channel Access nor with Switched Data Individual Line Loop Extension.

Data Last Number Redial. Data Last Number Redial permits redialing the last called number by depressing a single key. Redial is not available with Switched Data Channel Access nor with Switched Data Individual Line Loop Extension.

Data Toll Restriction. Data Toll Restriction will block toll calling over Switched Data Lines.

Data Sequential Hunt Group. Data Sequential Hunt Group pilot telephone number to a group of lines. Hunting is sequential, starting at the first line assigned to the pilot telephone number and ending at the last line.

Effective: April 1, 2016

---

SWITCHED DATA SERVICES

III. SPECIAL CONDITIONS (Conditions)

B. Description of Services (Continued)

Feature Package Data 2000. (In addition to services included in Feature Package Data 1000)

Data Call Back. Data Call Back notifies a user encountering a busy station to be notified when the station becomes idle and automatically establish the call. Data Call Back is available with Centrex intercom calling but not with Switched Data Channel Access nor with Switched Data Individual Line Loop Extension.

Data Saved Number Redial. Data Saved Number Redial allows a redialing a saved number by depressing a single key. Redial is not available with Switched Data Channel Access nor with Switched Data Individual Line Loop Extension.

Data Circular Hunting. Data Circular Hunting assigns a pilot telephone number to the hunt group. Hunting starts after the first idle line found by the previous hunt and continues until the hunting starting point is reached. Hunting is not available with Switched Data Channel Access nor with Switched Data Individual Line Loop Extension.

Data Group Speed Calling. Data Group Speed Calling permits abbreviated dialing for a list of numbers shared by a group of data lines. The list may be updated either by a service order or by a designated user (controller). Additions, changes, or deletions of numbers can be made only from the controller's line. Other lines with access to this list are restricted. Speed Calling is available with Centrex intercom calling but is not available Data Channel Access nor with Switched Data Individual Line Loop Extension.

Data Individual Speed Call-Long List. Long List is the same as the Data Individual Speed Call Short-List except a Long List permits up to thirty stored numbers. Long List is limited to Switched Data lines but is not available with Switched Data Channel Access nor with Switched Data Individual Line Loop Extension.

C. General

Switched Data Service will be furnished only where facilities are available. Service is offered on a limited basis by specific switching systems within certain geographical areas. Since this service is not offered in all areas, it is important to verify its availability by contacting your Company Account Representative or Business Office at the telephone number listed in your telephone directory under the heading "WHERE TO REACH FRONTIER", for Installation/Service.

The minimum billing for which service is provided is one month.

Customer Premises Channelization may be provided by the customer or the Utility. If the Utility provides channelization, at a customer's premises the customer is not required to provide a channel access card. Channel termination equipment shall be placed at a single equipment location on the customer's premises. The customer must provide floor space, a temperature controlled environment, and a 120 volt, 60 Hz AC power service. Emergency backup power and ring generating equipment services are available at charges and rates developed for each individual case.

Effective: April 1, 2016

---

SWITCHED DATA SERVICES

III. SPECIAL CONDITIONS (Conditions)

C. General (Continued)

Switched Data Channel Access or Switched Data Individual Line Loop Extension is required for customers located in areas which are restricted by the technical requirements as specified herein, or in a local serving central office which is not capable of providing Switched Data. The Utility will determine the nearest central office capable of providing Switched Data Service. Interoffice IntraLATA digital high capacity mileage (1.544) will apply for Switched Data Channel Access from the non-capable central office to the central office capable of providing Switched Data at the mileage rate, excluding the Special Transport Termination rate. In this situation, the customer will utilize the dialing plan associated with the central office that delivers the digital dial tone.

Interoffice Digital Data Service (DDS) Special Transport mileage apply for Switched Data Individual Line Loop Extension from the non-capable central office to the central office capable of providing Switched Data Services. If Switched Data Services cannot be provided from the customer's serving central office, Switched Data Channel Access or Switched Data Individual Line Loop Extension may be required in lieu of the Switched Data Low Speed or High Speed Line Service.

D. Application of Rates

Switched Data Centrex Line rates are determined by the total number of either Low Speed or either High Speed lines (i.e., if a customer requests 55 Low Speed lines and 25 High Speed lines, all 55 Low Speed lines will be billed at the "50-100" rate and all 25 High Speed lines will be billed at the "2-49" rate).

Rates and charges specified in other tariff or Product Guide schedules for services provided in conjunction with Switched Data service (Business Shared Private Line features, Centrex features, etc.) are in addition to the monthly rates for Switched Data service.

Customer Premises Channelization is an optional component of Switched Data Channel Access. The customer has the option to support premises channelization with CPE devices or to be made available by the Utility. Both the Customer Premises Channelization charge, per channel and the Customer Premises Termination charge, per access arrangement (24 channels) will apply.

End User charges as specified in the End User Facilities for Interstate Access (FIA) of Frontier Operating Companies Tariff FCC No. 14 will apply to Switched Data service. For each Switched Data Channel Access and Switched Data Individual Line Loop Extension the End User FIA charge will apply twice.

For Presubscription of an Interexchange Carrier, the rates and regulations as set forth in Frontier Operating Companies Tariff FCC No. 14 will apply to Switched Data service.

A directory listing for Switched Data service will be provided upon request.



Effective: April 1, 2016

---

SWITCHED DATA SERVICES

III. SPECIAL CONDITIONS (Conditions)

E. Access Dialing

Access to Switched Data service is obtained through a dial connection via the public switched telephone network using the standard 7 through 10 digit methods.

Origination of calls for 800, 900, 976, 0-(IntraLATA) and 0+ (IntraLATA) is limited to voice calls only. These calls will be provided with the Voice Option feature of Switched Data service when requested by the customer.

F. Technical Limitations

Switched Data service requires the use of customer provided data equipment that is compatible with the Utility's equipment and facilities. Visit charges apply for visits by the Utility to a customer's premises if a service difficulty results from customer-provided facilities or equipment.

Customers may be affected by technological limitations because of digital signal power loss. Beyond the following limitations, customers will be served with Switched Data Individual Line Loop Extensions or Switched Data Channel Access:

DMS-100: 42dB loss at 80 kilohertz, equating to a maximum route length ranging from 12,000 feet to 18,000 feet, depending on cable gauge and customer wiring.

GTD-5: 26dB loss at 80 kilohertz, equating to a maximum route length ranging from 8,000 feet to 15,000 feet, depending on cable gauge and customer wiring.

5ESS (non-ISDN equipped): 42dB loss at 80 kilohertz, equating to a range from 12,000 feet to approximately 14,000 feet depending on cable gauge and including customer wiring.

If these losses are exceeded for a customer, the customer must subscribe to Switched Data Individual Line Loop Extension Service.

G. Service Interruption

Provisions concerning allowance for interruptions in service are set forth in the General Exchange Tariff, Schedule D&R, Rule No. 21.

H. Special Construction

All rates and charges set forth in this Schedule apply if suitable facilities are available. If special construction is necessary, the special construction charges set forth in the General Exchange Tariff, Schedule D&R, Rule No. 27 apply.

I. Discounts for Qualifying Entities

See the General Exchange Tariff, Schedule No. K-8 for qualifications and discounts for Schools, Libraries, Health Care Providers, and Community Based Organizations.

Effective: April 1, 2016

---

CUSTOMER OWNED PAY TELEPHONE (COPT) RESALE SERVICES

TABLE OF CONTENTS

	<u>SHEET NO.</u>
I. APPLICABILITY	1
II. DESCRIPTION OF SERVICE	1
III. RATES AND CHARGES	2

Effective: April 1, 2016

---

CUSTOMER OWNED PAY TELEPHONE (COPT) RESALE SERVICES

I. APPLICABILITY

This Product Guide is applicable to Customer Owned Pay Telephone (COPT) Resale Services provided to Resellers who have an approved Certificate of Public Convenience and Necessity (CPCN) authorizing them to operate in the State of California as outlined in D.95-07-054.

Competitive Local Exchange Carriers (CLECs) are prohibited from reselling COPT Service to any COPT-operating affiliated entity.

II. DESCRIPTION OF SERVICE

See Section 34 for the Description, Terms, Conditions and Regulations for Customer Owned Pay Telephone (COPT) Service. See the General Exchange Tariff, Schedule No. K-4 for resale rates for associated services.

Effective: April 1, 2016

CUSTOMER OWNED PAY TELEPHONE (COPT) RESALE SERVICES

III. RATES AND CHARGES

		<u>Nonrecurring Charge</u>	<u>Monthly Rate</u>
A.	Basic Exchange Service		
1.	Coin Line Service Fixed Rate <sup>3</sup> , per line	--	\$23.28
2.	COPT Service Measured <sup>2, 5</sup> , per line	--	21.90
	Measured <sup>6</sup> , per line	--	26.18
(a)	Optional Features		
(1)	Answer Supervision per line	--	3.47
(b)	Call Restriction Services		
(1)	Option II	4	1.75
(2)	Option IV	--	1.75
(3)	Option V	4	
(4)	Billed Number Screening	4	.27
(c)	Billing and Collecting of Pay Station Service Charge		
(d)	Compensable Call Tracking Report (CCT)	<u>Nonrecurring Charge Per Pay Phone</u>	
	One Time Set-Up Charge		
	1 - 100 Pay Phones, per Pay Phone	\$.88	
	101 - 999 Pay Phones, per Pay Phone	.66	
	1000 - plus Pay Phones, per Pay Phone	.44	
	Quarterly Recurring Charge, per Pay Phone		<u>Quarterly Rate</u> \$ .22

<sup>1</sup> Nonrecurring Charges are applicable.

<sup>2</sup> Local usage rates are applicable.

<sup>3</sup> Per call rates also apply.

<sup>4</sup> Nonrecurring Charges are applicable.

<sup>5</sup> Rates are applicable to customers in exchanges listed in Section 5, Sheet 2.

<sup>6</sup> Rates are applicable to customers in exchanges listed in Section 5, Sheet 3.

Effective: September 24, 2017

---

CALIFORNIA TELECONNECT FUND (CTF) DISCOUNTED SERVICES

TABLE OF CONTENTS

	<u>SHEET NO.</u>
I. APPLICABILITY	1
II. TERRITORY	1
III. AVAILABILITY	1
IV. FUNDING	2
V. DISCOUNTS APPLICABLE TO ELIGIBLE SERVICES	2
VI. HOW DISCOUNTS ARE APPLIED	4

Effective: July 1, 2019

---

CALIFORNIA TELECONNECT FUND (CTF) DISCOUNTED SERVICES

I. APPLICABILITY

Applicable to qualifying schools, libraries, municipal and county government or hospital district owned and operated hospital and health clinic, and community based organizations.

II. TERRITORY

Applicable to the suburban areas of exchanges where service is provided from Central Offices and/or Operating Systems capable of providing California Teleconnect Fund (CTF) Discounted Services as said exchanges are defined on the maps contained in the General Exchange Tariff, Schedule AB.

III. AVAILABILITY

A. In Decision 96-10-066, the California Public Utilities Commission (CPUC) established the CTF. This program provides discounts on telecommunications services delineated herein to qualifying Schools, Libraries, Hospitals and Health Clinics, Community Based Organizations and California Community Colleges, approved by the CPUC, as described below.

B. These organizations must apply to the California Public Utilities Commission for the CTF program discount and receive approval of their application prior to the discount being applied, pursuant to the process described in Resolution T-16742.

C. The following business services are subject to a 50% non-voice discount on all monthly rate(s) (excluding the non recurring charges) for eligible entities where services are available as follows:

(C)

(D)

(D)

50% non-voice discount on the following:

- Digital Central Office Services – Datapath
- Digital Channel Service (T-1 or DS1 equivalent) located in the Company's Facilities for Intrastate Access Tariff, Section III
- High Capacity Digital Service or functional equivalents (including, but not limited to, DS3) located in the Company's Facilities for Intrastate Access Tariff, Section III
- Integrated Services Digital Network (ISDN) – Basic Rate Interface (BRI) Service
- Integrated Services Digital Network (ISDN) – Primary Rate Interface (PRI) Service

D. These discounted services may not be resold to, or shared with, any other non-qualifying person or entity.

E. CTF participants shall renew their exemption from reduced services support every 3 years. Once an exemption is obtain, it shall be retained for a period of three years.

(D)

(D)

Effective: July 1, 2019

---

CALIFORNIA TELECONNECT FUND (CTF) DISCOUNTED SERVICES

III. AVAILABILITY (Continued)

(D)

(D)

IV. FUNDING

If the Executive Director of the California Public Utilities Commission (CPUC) determines that there are insufficient funds to reimburse the Utility for its claims against the CTF, the CPUC will promptly inform the Utility concerning this condition and direct the Utility to suspend the offering of applicable discounted rates to qualifying Schools, Libraries, Government Owned Hospitals, Government Owned Health Clinics, and Community Based Taxed Exempt Organizations on a schedule consistent with fund balances and utility claims and with appropriate prior notice to customers.

V. DISCOUNTS APPLICABLE TO ELIGIBLE SERVICES

A. Schools and Libraries

1. To qualify for the discount, schools must be public or nonprofit schools providing elementary or secondary education and which do not have endowments of more than \$50 Million. Only those libraries, which are eligible for participation in state based plans for funds under Title III of the Library Services and Technology Act qualify for the discount.
2. Qualifying schools and libraries shall be entitled to a 25%<sup>1</sup> voice/50% non-voice discount off tariffed and/or Product Guide rates or negotiated/contract rates, whichever are lower, for services identified in III.C. preceding, after first deducting the applicable E-rate discounts. The discount shall be calculated as follows:
  - a. If the customer has not been approved to receive E-rate discounts, whether or not an application is pending, the discount will be applied to all eligible services after deducting a statewide average E-rate discount (determined by the CPUC) from the billed amount.
  - b. For Federal E-rate program participants, the CTFs discount applies to eligible service costs minus the Federal E-rate subsidy. For E-rate schools, the CTF discount amount shall be no higher than their Federal E-rate subsidy.
  - c. The statewide average discount is deducted from the customer's services solely for purposes of calculating the CTF discount. The statewide average discount shall be added back to the billed amount for payment by the customer. However, when the customer receives its approved E-rate benefit, the customer's account will be retroactively adjusted to reflect the approved E-rate.

(D)  
(D)

(D)  
(D)

Effective: July 1, 2019

---

CALIFORNIA TELECONNECT FUND (CTF) DISCOUNTED SERVICES

V. DISCOUNTS APPLICABLE TO ELIGIBLE SERVICES (Continued)

A. Schools and Libraries (Continued)

3. The following schools and libraries shall be entitled to a 50% non-voice discount off the entire tariffed and/or Product Guide rates or negotiated/contract rates, whichever are lower, for services identified in III.C. preceding: small schools as defined in Section 42283 of the Education Code, participants whose E-rate applications have been denied, and participants who subscribe to services that are ineligible for E-rate discounts. (C)

B. Health Care Providers

1. Must be district owned, municipal or county government owned and operated hospital or health clinic.
2. Qualifying hospitals and health clinics shall be entitled to a 50% non-voice discount off tariffed and/or Product Guide rates or negotiated/contract rates, whichever is lower, net of the Federal Communications Commission's Federal Rural Health Care discounts, as authorized by D. 96-10-066. Public or non-profit healthcare providers in rural areas may be eligible for Federal Rural Health Care discounts equal to the difference between urban and rural rates. (C)

C. Community Based Organizations (CBOs)

1. Must be tax-exempt organizations offering Head Start Programs, Health Care, Job Training, Job Placement, or Educational Instruction, or a Community Technology Program offering access to and training in the Internet and other technologies. A "tax exempt organization" shall refer to an organization described in Section 501 (c) (3) or 501(d) of the Internal Revenue Code, Title 26 of the United States Code. In order to qualify for the CBO discount, the CBO must provide proof at the time of application that it is a tax exempt organization and that it offers healthcare, job training, job placement, or educational instruction. Public or non-profit CBO healthcare providers in rural areas may be eligible for Federal Rural Health Care discounts equal to the difference between urban and rural rates.
2. Qualifying CBOs shall be entitled to a 50% non-voice discount off tariffed and/or Product Guide rates or the rates charged to other businesses for those same services, whichever is lower. CBOs offering Head Start programs shall be entitled to a 50% non-voice discount off tariffed and/or Product Guide rates or negotiated/contract rates, whichever is lower, net of the Federal Communications Commission's E-Rate Discounts. (C)

D. California Community Colleges (CCCs)

- Participating California Community Colleges (CCCs) shall be entitled to a 50% non-voice discount off the entire tariffed and/or Product Guide rates or negotiated/contract rates, whichever are lower. (C)

(D)

(D)



Effective: July 1, 2019

---

CALIFORNIA TELECONNECT FUND (CTF) DISCOUNTED SERVICES

V. DISCOUNTS APPLICABLE TO ELIGIBLE SERVICES (Continued)

E. Rural Health Care Providers (RHCP)

Public or non-profit healthcare providers in rural areas may be eligible for Federal rural healthcare discounts under the Rural Health Care Program of the Universal Service Fund. Rural Health Care (RHC) funding received by a RHCP shall first be taken into account prior to applying the CTF discount to the eligible service charges subscribed by the RHCP. The 50% non-voice voice CTF discount shall be calculated as follows:

1. The 50% non-voice discount shall be applied to the entire CTF eligible service charges subscribed by the RHCP that does not apply for Rural Health Care (RHC) funding in a given fiscal year. (C)
2. The 25%<sup>1</sup> voice/50% non-voice discount shall be applied to the entire CTF eligible service charges subscribed by the RHCP awaiting approval for RHC funding for the fiscal year. Once approved, the CTF discount shall be trueed up for that fiscal year to take into account the RHC funding received. (C)

VI. HOW DISCOUNTS ARE APPLIED

- A. Federal funding or subsidy given to CTF participants for their CTF-eligible services shall first be taken into account prior to applying the CTF discount, as specifically noted in B through F below.
- B. By September 21, 2011, the Utility shall first apply the actual federal E-rate discount prior to applying the CTF discount to Community Based Organizations (CBOs) that offer Head Start programs with an actual E-rate discount.
- C. The Utility shall first apply the statewide average E-rate discount developed and updated annually by the Commission effective July 1<sup>st</sup> prior to applying the CTF discount if the school, library, and/or CBO that offers Head Start programs does not have an actual E-rate. However the implementation of deducting the statewide average E-rate discount before applying the CTF discount will not take effect until July 1, 2012, for CBOs offering Head Start programs that do not have an actual E-rate.
- D. Necessary Small Schools are exempt from deducting the statewide average E-rate discount if they do not have an actual E-rate discount. Notwithstanding subdivision (b), the CTF discount shall be applied without regard to the E-rate discount for any Necessary Small School, as defined in Section 42283 of the Education Code, unless that school has applied for, and been approved to receive, the E-rate discount.
- E. The Utility shall apply the CTF discounts to Rural Health Care Providers (RHCP) as follows:
  1. Apply 50 percent CTF discount on CTF-eligible services subscribed to by RHCPs that did not apply for RHC funding in a given fiscal year.
  2. Apply 50 percent CTF discount on CTF-eligible services subscribed to by RHCPs while awaiting approval for RHC funding for FY 2012-13 and beyond, then true-up the CTF discount for that FY.
  3. Adjust the CTF discount received by RHCPs when RHC funding is received after the issuance date of Resolution T-17314 for funding for FY 2010-11 and FY 2011-12.
  4. By September 21, 2011, the Utility shall deduct any federal funding received by RHCPs first before applying the CTF discount on CTF-eligible services.
  5. The Utility shall continue to apply the 50 percent CTF discount on CTF-eligible services for RHCPs that do not apply for RHC funding.
- F. A teleconnect discount shall be applied after applying an E-Rate discount. The commission shall first apply an E-rate discount, regardless of whether the customer has applied for an E-rate discount or has been approved, if the customer, in the determination of the commission, meets the eligibility requirements for an E-Rate discount.

Effective: April 1, 2016

---

DEFINITIONS AND RULES

TABLE OF CONTENTS

Preliminary Statement  
Definitions

RULES

Rule No. 1	Description of Service
Rule No. 2	Application for Service
Rule No. 3	Disclosure of Rates and Charges and Information to be Provided to the Public
Rule No. 4	Special Information Required on Forms
Rule No. 5	Establishment & Reestablishment of Credit
Rule No. 6	Deposits
Rule No. 7	Return of Deposit - Interest on Deposit
Rule No. 8	Priority of Establishment and Supersedure of Service
Rule No. 9	Rendering and Payment of Bills
Rule No. 10	Discontinuance of Service
Rule No. 11	Disputed Bills
Rule No. 12	Notices
Rule No. 13	Monitoring and/or Recording of Telephone Conversations
Rule No. 14	Basis of Mileage Charges
Rule No. 15	Changes in Telephone Number
Rule No. 16	Ownership and Use of Facilities on Customer's Premises
Rule No. 17	Ownership and Use of Telephone Directories
Rule No. 18	Business and Residence Service
Rule No. 19	Service Connections to be made by Utility Employees
Rule No. 20	Utility's Right of Ingress to and Egress from Customer's Premises
Rule No. 21	Limitation of Liability
Rule No. 22	Customer's Private Service not for Public Use
Rule No. 23	Contracts
Rule No. 24	Pole Attachments
Rule No. 25	Legal Requirements for Refusal or Discontinuance of Service
Rule No. 26	Appendix "B" of Decision No. 91188
Rule No. 27	Plant Extensions, Service Connections and Special Construction on Premises of Customer
Rule No. 28	Temporary Service or Speculative Projects
Rule No. 29	Limitation on Charges for Service
Rule No. 30	Emergency Measures Taken Pursuant to a "State of Extreme Emergency"
Rule No. 31	List of Contracts and Deviations
Rule No. 32	Alternative Service Arrangements During Critical Service Outages
Rule No. 33	Facilities to Provide Replacement of Aerial with Underground Facilities
Rule No. 34	Customer-Provided Facilities Connected to Utility Exchange Facilities
Rule No. 35	Extended Payment of One-Time Charges for Business Services
Rule No. 36	Connection and Use of Automatic Dialing-Announcing Devices
Rule No. 37	Nonpublished Service
Rule No. 38	Release of Credit Information and Calling Records
Rule No. 39	Market Trials and Technology Tests

FRONTIER CALIFORNIA INC.  
9260 E. Stockton Blvd., Elk Grove, CA 95624

PRODUCT GUIDE  
Section D&R  
Original Sheet 2

Effective: April 1, 2016

---

DEFINITIONS AND RULES

Definitions and Rules for Service Catalog services may be found in the General Exchange Tariff, Schedule No. D&R.

Effective: April 1, 2016

---

GRANDFATHERED SERVICES – CUSTOM CALLING & FEATURE PACKAGES

TABLE OF CONTENTS

	<u>SHEET NO.</u>
CUSTOM CALLING SERVICE	1
A. Individual Calling Services	1
1. Call Waiting	1
2. Busy Number Redial	1
3. Last Number Redial	1
4. Saved Number Redial	1
5. Cancel Call Waiting	1
6. Special Call Waiting	1
7. Priority Call	2
8. Do Not Disturb	2
9. Call Block	2
10. Caller ID – Number Only	2
Rates and Charges	
1. Call Waiting	3
2. Busy Number Redial	3
3. Last Number Redial	3
4. Saved Number Redial	3
5. Cancel Call Waiting	3
6. Special Call Waiting	3
7. Priority Call	3
8. Do Not Disturb	3
9. Caller ID – Number Only	3
B. Package Services	
1. Feature Pack 4400	4
2. Feature Pack 4900	4
3. Flexible Packaging	4
Rates and Charges	
1. Feature Pack 4400	5
2. Feature Pack 4900	5
3. Flexible Packaging	5
4. Complete Call Forwarding Package	6
5. Distinctive Ring with Packs	7
6. Sharper Call Pack	7
7. Sharpest Call Pack	7

Effective: April 1, 2016

---

GRANDFATHERED SERVICES – CUSTOM CALLING & FEATURE PACKAGES

CUSTOM CALLING SERVICE

A. INDIVIDUAL SERVICES

1. Call Waiting <sup>1</sup>

Call Waiting permits the customer engaged in a call to receive a tone signal indicating a second call is waiting, and by operation of the switchhook, to place the first call on hold and answer the waiting call. The customer may alternate between the two calls by operation of the switchhook, but a three-way conference cannot be established.

2. Busy Number Redial <sup>2,5</sup>

Busy Number Redial allows a customer to dial a code when a busy telephone number is reached. The call is retried automatically until both parties are available. Only busy calls within the central office are retried automatically.

3. Last Number Redial <sup>2,3,5</sup>

Last Number Redial allows a customer to dial a code to reinitiate the switch to automatically place a call to a specific number stored even if the customer has made subsequent calls to other numbers.

4. Saved Number Redial <sup>2,5</sup>

Saved Number Redial allows a customer to dial a code to reinitiate the switch to automatically place a call to a specific number stored even if the customer has made subsequent calls to other numbers.

5. Cancel Call Waiting <sup>1</sup>

Cancel Call Waiting allows a customer with call waiting service to inhibit the operation of call waiting for one call.

6. Special Call Waiting <sup>2,4</sup>

Special Call Waiting allows a customer to select up to 12 numbers which can activate Call Waiting. Incoming calls placed from numbers not selected by the customer receive busy signals when the customer's line is busy.

<sup>1</sup> Grandfathered and limited to existing customers at existing locations as of May 26, 2005.

<sup>2</sup> Grandfathered and limited to existing individual line residence customers currently subscribing to this service at the same customer premises as of Jan. 27, 1997.

<sup>3,4</sup> Residential Last Number Redial and Special Call Waiting Services are withdrawn as of November 16, 2013.

<sup>5</sup> Sharpest Call Pack for business customers is withdrawn as of July 21, 2014. Effective October 18, 2014, this service is also withdrawn at the resale level and no longer available for purchase by resale customers.

Effective: April 1, 2016

---

GRANDFATHERED SERVICES – CUSTOM CALLING & FEATURE PACKAGES

CUSTOM CALLING SERVICE (Continued)

A. INDIVIDUAL SERVICES (Continued)

7. Priority Call <sup>1</sup>

Priority Call allows a customer to program up to twelve (12) telephone numbers of selected callers enabling the customer to distinguish certain incoming calls from all others by a distinctive ring tone. If a customer also subscribes to Call Waiting<sup>2</sup>, calls from the selected numbers will be distinguished by a special Call Waiting tone

8. Do Not Disturb <sup>1</sup>

Do Not Disturb allows a customer to select up to twelve (12) telephone numbers from which calls are to be received. All other calls originating from the customer's exchange are intercepted and routed to a recorded announcement that informs the caller the customer is not accepting calls. Callers diverted to the recorded announcement will not be billed usage charges.

9. Call Block <sup>1</sup>

Call Block allows a customer to block incoming calls from a maximum of twelve (12) numbers. The customer can also block incoming calls placed from the last calling number even if the number is unknown to the customer. The automatic voiceback feature has been disabled and will not voiceback the calling party's telephone number. Blocked calls are routed to a recorded announcement which specifies that the called party is not accepting calls. Callers diverted to the recorded announcement will not be billed usage charges.

10. Caller ID - Number Only <sup>2,3</sup>

Service provides for the display of an incoming telephone number on a customer provided display device attached to the customer's telephone line or on a telephone or answering machine with a built-in display screen. Service can be provided to customers subscribing to rotary service. The Caller ID - Number Only feature will forward the calling number from the appropriately equipped central office to the customer provided display device, typically by the second ring. The Company will forward non-blocked telephone numbers (including Nonpublished and Nonlisted telephone numbers) subject to technical and other limitations, including the availability of the number for forwarding. Anonymous Call Block is included with this service at no additional cost where facilities and conditions permit.

All customer provided equipment used to interface with Caller ID - Number Only must be connected in accordance with the provisions of the Federal Communications Commission's Registration program. Any intent to sell name(s) and/or number(s) gathered as a result of Caller ID - Number Only is prohibited. This service is available only where facilities and conditions permit.

<sup>1</sup> Grandfathered and limited to existing customers at existing locations as of March 21, 2005.

<sup>2</sup> Grandfathered and limited to existing customers at existing locations as of May 26, 2005.

<sup>3</sup> Residential Caller ID - Number Only Service is withdrawn as of November 16, 2013.

Effective: May 1, 2024

---

GRANDFATHERED SERVICES – CUSTOM CALLING & FEATURE PACKAGES

CUSTOM CALLING SERVICE (Continued)

A. INDIVIDUAL SERVICES (Continued)

RATES AND CHARGES

	<u>Monthly Rate</u>	
	<u>Bususiness</u>	<u>Residence</u>
1. Call Waiting <sup>1</sup>	\$12.50 (I)	\$8.00
2. Busy Number Redial <sup>2</sup>	4.00	4.00
3. Last Number Redial <sup>2</sup>	4.00	<sup>3</sup>
4. Saved Number Redial <sup>2</sup>	4.00	4.00
5. Cancel Call Waiting <sup>1</sup>	2.00	2.50
6. Special Call Waiting <sup>2,4</sup> , per line	5.00	<sup>3</sup>
7. Priority Call <sup>4,5</sup> , per line	3.00	5.50
8. Do Not Disturb, per line <sup>4,6</sup>	2.50	5.00
9. Caller ID - Number Only <sup>1,7</sup> , per line	12.00 (I)	<sup>3</sup>

<sup>1</sup> Grandfathered and limited to existing customers at existing locations as of May 26, 2005.

<sup>2</sup> Grandfathered and limited to existing individual business and residence customers currently subscribing to this service at the same customer premises only as of Jan. 27, 1997.

<sup>3</sup> Material formerly on this page has been withdrawn from the Product Guide. Residential Last Number Redial, Special Call Waiting and Caller ID - Number Only Services are withdrawn as of November 16, 2013.

<sup>4</sup> Flexible Rate Ranges have been established for this service.

<sup>5</sup> Grandfathered and limited to existing customers at existing locations as of March 21, 2005.

<sup>6</sup> Grandfathered and limited to existing customers at existing locations as of March 21, 2005. No moves, additions or changes will be permitted.

<sup>7</sup> Appropriate nonrecurring charges as set forth in Section 3 of this Product Guide apply.

Effective: April 1, 2016

---

GRANDFATHERED SERVICES – CUSTOM CALLING & FEATURE PACKAGES

CUSTOM CALLING SERVICE (Continued)

B. PACKAGE SERVICES

1. Feature Pack 4400 <sup>1</sup>

Feature Pack 4400 includes the following services:

- Busy Redial
- \*69
- Call Block
- Call Waiting
- Distinctive Ring is available as an option

2. Feature Pack 4900 <sup>1</sup>

Feature Pack 4900 includes all the services included in Feature Pack 4400 plus the following services:

- Priority Call
- Cancel Call Waiting
- Call Forwarding
- Three-Way Calling
- Speed Dialing 8 Code
- Distinctive Ring is available as an option

3. Flexible Packaging <sup>1</sup>

- a. This service offers a discount off the rates for the following Custom Calling Service features, provided the customer orders four or more features on the same residential account.

Features:

- Busy Redial
- \*69
- Call Block
- Call Forwarding (Flexible)
- Call Waiting
- Call Waiting / Cancel Call Waiting
- Caller ID
- Calling ID - Number Only
- Distinctive Ring
- Do Not Disturb
- Select Call Forwarding
- Speed Dialing (8 Code Capacity)
- Speed Dialing (30 Code Capacity)
- Three Way Calling
- Priority Call

- b. Flexible packaging is available to single line residence customers only.

<sup>1</sup> Grandfathered and limited to existing customers at existing locations as of March 21, 2005. No moves, additions or changes will be permitted.



Effective: April 1, 2016

---

GRANDFATHERED SERVICES – CUSTOM CALLING & FEATURE PACKAGES

CUSTOM CALLING SERVICE (Continued)

B. PACKAGE SERVICES (Continued)

3. Flexible Packaging <sup>1</sup> (Continued)

- c. Once four or more of the features are subscribed to, the discount will apply to all of these features.
- d. If the number of qualifying features ordered is less than four, or the customer removes a feature or features such that the total subscribed to become less than four, the discount does not apply.
- e. One feature may be substituted for another, or other features may be added at a later date.
- f. All features that qualify under flexible packaging will be discounted by the percentage indicated in Rates following.
- g. Nonrecurring Charges as set forth in Section 3 of this Product Guide are applicable to customers ordering flexible packaging. These charges are not applicable when one feature is substituted for another in the flexible package or when other features are added to the flexible package after the initial installation of a flexible package.

RATES AND CHARGES

	<u>Monthly Rate</u>	
	<u>Business</u>	<u>Residence</u>
1. Feature Pack 4400, per line <sup>2,3</sup>	n/a	\$13.25
2. Feature Pack 4900, per line <sup>2,3</sup>	n/a	16.75
3. Flexible Packaging <sup>3,4</sup>		

All features that qualify under the flexible packaging offering will be discounted by 40% for residential customers.

<sup>1</sup> Flexible Packaging is grandfathered and limited to existing customers at existing locations as of March 21, 2005. No moves, additions or changes will be permitted.

<sup>2</sup> Flexible Rate Ranges have been established for this service.

<sup>3</sup> Grandfathered and limited to existing customers at existing locations as of March 21, 2005. No moves, additions or changes will be permitted.

<sup>4</sup> Section 3 Nonrecurring Charges will not be applicable to Flexible Packaging or 150 Satellite Channel Programming PAC customers when, (a) ordering Flexible Packaging or 150 Satellite Channel Programming PAC, (b) when one feature is substituted for another in Flexible Packaging or 150 Satellite Channel Programming PAC or (c) when other features are added to Flexible Packaging or 150 Satellite Channel Programming PAC after the initial installation of a Flexible Packaging or 150 Satellite Channel Programming PAC.

Effective: April 1, 2016

GRANDFATHERED SERVICES – CUSTOM CALLING & FEATURE PACKAGES

CUSTOM CALLING SERVICE (Continued)

B. PACKAGE SERVICES (Continued)

RATES AND CHARGES (Continued)

	<u>Monthly Rate</u>	
	<u>Business</u>	<u>Residence</u>
4. Complete Call Forwarding Package <sup>1</sup> includes Fixed Call Forwarding, Call Forwarding Busy-Line--Fixed and Call Forwarding No-Answer--Fixed	\$4.00	\$ .00
a. Two Feature Packages		
(i) Call Forwarding and Call Waiting <sup>2, 5</sup>	4.25	6.75
(ii) Call Forwarding and Three Way Calling	5.00	6.75
(iii) Call Forwarding and Speed Dialing 8	4.25	6.75
(iv) Call Waiting <sup>2</sup> and Three Way Calling	4.25	6.75
(v) Call Waiting/Cancel Call Waiting and Three Way Calling	5.25	7.75
(vi) Call Waiting <sup>2</sup> and Speed Dialing 8 <sup>5</sup>	4.25	6.75
(vii) Call Waiting/Cancel Call Waiting and Speed Dialing 8	5.25	7.75
(viii) Three Way Calling and Speed Dialing 8 <sup>4</sup>	4.25	-
b. Three Feature Packages		
(i) Call Forwarding, Call Waiting, <sup>2</sup> and Three Way Calling	4.25	7.75
(ii) Call Forwarding, Call Waiting, <sup>2</sup> and Speed Calling 8	4.25	7.75
(iii) Call Forwarding, Three Way Calling, and Speed Calling 8 <sup>4</sup>	5.00	-
(iv) Call Waiting <sup>2</sup> , Three Way Calling and Speed Calling 8	4.25	7.75
c. Remote Activation of Call Forwarding <sup>3</sup>	2.50	42.50

<sup>1</sup> Grandfathered and limited to existing customers at existing locations as of July 1, 2007.

<sup>2</sup> These packaged offerings are grandfathered and limited to existing customers at existing locations as of March 21, 2005.

<sup>3</sup> This service is grandfathered and limited to existing individual business and residence customers currently subscribing to the service at the same customer premises only as of June 14, 2004.

<sup>4</sup> Residential Two Feature Package, Three Way Calling and Speed Dialing 8 and Residential Three Feature Package, Call Forwarding, Three Way Calling, and Speed Calling 8, are withdrawn as of November 16, 2013.

<sup>5</sup> Business Call Forwarding and Call Waiting, and Business Call Waiting and Speed Dialing 8 Two Feature Packages are withdrawn as of July 21, 2014. Effective October 18, 2014, these services are also withdrawn at the resale level and no longer available for purchase by resale customers.

Effective: April 1, 2016

GRANDFATHERED SERVICES – CUSTOM CALLING & FEATURE PACKAGES

CUSTOM CALLING SERVICE (Continued)

B. PACKAGE SERVICES (Continued)

RATES AND CHARGES (Continued)

	<u>Monthly Rate</u>	
	<u>Business</u>	<u>Residence</u>
5. Distinctive Ring with Paks <sup>1</sup> specified below Sharper Call Pack Sharpest Call Pack <sup>5</sup> Feature Pack 4400 Feature Pack 4900	\$3.00 <sup>3</sup>	\$5.50 <sup>2</sup>
6. Sharper Call Pack <sup>4</sup> , each line (includes call forwarding, call waiting, three way calling and one of the following speed dialing services)		
a. Eight-code capacity	8.00	10.25
b. Thirty-code capacity	5.25	9.75
7. Sharpest Call Pack <sup>4</sup> , each line (includes call forwarding, call waiting / cancel call waiting, three way calling, busy number redial, last number redial, saved number redial and one of the following speed dialing services)		
a. Eight-code capacity	7.00	10.50
b. Thirty-code capacity <sup>5</sup>	8.00 <sup>5</sup>	11.50

<sup>1</sup> The monthly rate is in addition to the monthly rate for the individual Paks.

<sup>2</sup> Grandfathered and limited to existing residential customers currently subscribing to this service at the same customer premises only as of Nov. 3, 1996.

<sup>3</sup> Grandfathered and limited to existing business customers at existing locations as of May 26, 2005.

<sup>4</sup> Grandfathered and limited to existing customers at existing locations as of March 21, 2005. No moves, additions or changes will be permitted.

<sup>5</sup> Sharpest Call Pack Thirty-code capacity for business customers is withdrawn as of July 21, 2014. Effective October 18, 2014, this service is also withdrawn at the resale level and no longer available for purchase by resale customers.